

Dynamical
Systems

III

VLADIMIR I. ARNOLD
VALERY V. KOZLOV
ANATOLY I. NEISHTADT

Mathematical Aspects of Classical and Celestial Mechanics

Third Edition



Encyclopaedia of Mathematical Sciences
Volume 3

Dynamical Systems III

Vladimir I. Arnold
Valery V. Kozlov
Anatoly I. Neishtadt

Mathematical Aspects of Classical and Celestial Mechanics

Third Edition

 Springer

Vladimir I. Arnold
Steklov Mathematical Institute
ul. Gubkina 8
GSP-1, 119991 Moscow, Russia
E-mail: arnold@mi.ras.ru

and
CEREMADE
Université Paris 9 – Dauphine
Place du Marechal de Lattre de Tassigny
F-75775 Paris Cedex 16-e, France
E-mail: arnold@ceremade.dauphine.fr

Valery V. Kozlov
Steklov Mathematical Institute
ul. Gubkina 8
GSP-1, 119991 Moscow, Russia
and
Department of Mathematics and Mechanics
Lomonosov Moscow State University
GSP-2, Leninskie Gory
119992 Moscow, Russia
E-mail: kozlov@pran.ru

Anatoly I. Neishtadt
Space Research Institute
Profsoyuznaya 84/32
Moscow 117997, Russia
and
Department of Mathematics and Mechanics
Lomonosov Moscow State University
GSP-2, Leninskie Gory
119992 Moscow, Russia
E-mail: aneishta@iki.rssi.ru

Translator

E. Khukhro
Cardiff School of Mathematics
Cardiff University
Senghennydd Road
CARDIFF, CF24 4AG, UK
E-mail: Khukhro@Cardiff.ac.uk

Founding editor of the Encyclopaedia of Mathematical Sciences:
R. V. Gamkrelidze

Original Russian edition (2nd ed.) published by URSS, Moscow 2002

Library of Congress Control Number: 2006929597

Mathematics Subject Classification (2000):

Primary: 34-02, 37-02, 70-02

Secondary: 34Cxx, 34Dxx, 34Exx, 37Axx, 37Bxx, 37Cxx, 37Dxx, 37Exx, 37Gxx,
37Jxx, 58K50, 70A05, 70Bxx, 70Exx, 70Fxx, 70Gxx, 70Hxx, 70Jxx, 70Kxx, 70M20

ISSN 0938-0396

ISBN-10 3-540-28246-7 Springer Berlin Heidelberg New York
ISBN-13 978-3-540-28246-4 Springer Berlin Heidelberg New York

This work is subject to copyright. All rights are reserved, whether the whole or part of the material is concerned, specifically the rights of translation, reprinting, reuse of illustrations, recitation, broadcasting, reproduction on microfilm or in any other way, and storage in data banks. Duplication of this publication or parts thereof is permitted only under the provisions of the German Copyright Law of September 9, 1965, in its current version, and permission for use must always be obtained from Springer. Violations are liable for prosecution under the German Copyright Law.

Springer is a part of Springer Science+Business Media
springer.com

© Springer-Verlag Berlin Heidelberg 2006

The use of general descriptive names, registered names, trademarks, etc. in this publication does not imply, even in the absence of a specific statement, that such names are exempt from the relevant protective laws and regulations and therefore free for general use.

Typesetting: by the authors and techbooks using a Springer L^AT_EX macro package

Cover design: E. Kirchner, Heidelberg, Germany

Printed on acid-free paper SPIN: 11387534 46/techbooks 5 4 3 2 1 0

Preface

In this book we describe the basic principles, problems, and methods of classical mechanics. Our main attention is devoted to the mathematical side of the subject. Although the physical background of the models considered here and the applied aspects of the phenomena studied in this book are explored to a considerably lesser extent, we have tried to set forth first and foremost the “working” apparatus of classical mechanics. This apparatus is contained mainly in Chapters 1, 3, 5, 6, and 8.

Chapter 1 is devoted to the basic mathematical models of classical mechanics that are usually used for describing the motion of real mechanical systems. Special attention is given to the study of motion with constraints and to the problems of realization of constraints in dynamics.

In Chapter 3 we discuss symmetry groups of mechanical systems and the corresponding conservation laws. We also expound various aspects of order-reduction theory for systems with symmetries, which is often used in applications.

Chapter 4 is devoted to variational principles and methods of classical mechanics. They allow one, in particular, to obtain non-trivial results on the existence of periodic trajectories. Special attention is given to the case where the region of possible motion has a non-empty boundary. Applications of the variational methods to the theory of stability of motion are indicated.

Chapter 5 contains a brief survey of the various approaches to the problem of integrability of the equations of motion and some of the most general and efficient methods of their integration. Diverse examples of integrated problems are given, which form the “golden reserve” of classical dynamics. The material of this chapter is used in Chapter 6, which is devoted to one of the most fruitful parts of mechanics – perturbation theory. The main task of perturbation theory is studying the problems of mechanics that are close to problems admitting exact integration. Elements of this theory (in particular, the well-known and widely used “averaging principle”) arose in celestial mechanics in connection with attempts to take into account mutual gravitational perturbations of the planets of the Solar System. Adjoining Chapters 5 and 6

is Chapter 7, where the theoretical possibility of integrating the equations of motion (in a precisely defined sense) is studied. It turns out that integrable systems are a rare exception and this circumstance increases the importance of approximate integration methods expounded in Chapter 6. Chapter 2 is devoted to classical problems of celestial mechanics. It contains a description of the integrable two-body problem, the classification of final motions in the three-body problem, an analysis of collisions and regularization questions in the general problem of n gravitating points, and various limiting variants of this problem. The problems of celestial mechanics are discussed in Chapter 6 from the viewpoint of perturbation theory. Elements of the theory of oscillations of mechanical systems are presented in Chapter 8.

The last Chapter 9 is devoted to the tensor invariants of the equations of dynamics. These are tensor fields in the phase space that are invariant under the phase flow. They play an essential role both in the theory of exact integration of the equations of motion and in their qualitative analysis.

The book is significantly expanded by comparison with its previous editions (VINITI, 1985; Springer-Verlag, 1988, 1993, 1997). We have added Ch. 4 on variational principles and methods (§ 4.4.5 in it was written by S. V. Bolotin), Ch. 9 on the tensor invariants of equations of dynamics, § 2.7 of Ch. 2 on dynamics in spaces of constant curvature, §§ 6.1.10 and 6.4.7 of Ch. 6 on separatrix crossings, § 6.3.5 of Ch. 6 on diffusion without exponentially small effects (written by D. V. Treshchev), § 6.3.7 of Ch. 6 on KAM theory for lower-dimensional tori (written by M. B. Sevryuk), § 6.4.3 of Ch. 6 on adiabatic phases, § 7.6.3 of Ch. 7 on topological obstructions to integrability in the multidimensional case, § 7.6.4 of Ch. 7 on the ergodic properties of dynamical systems with multivalued Hamiltonians, and § 8.5.3 of Ch. 8 on the effect of gyroscopic forces on stability. We have substantially expanded § 6.1.7 of Ch. 6 on the effect of an isolated resonance, § 6.3.2 of Ch. 6 on invariant tori of the perturbed Hamiltonian system (with the participation of M. B. Sevryuk), § 6.3.4 of Ch. 6 on diffusion of slow variables (with the participation of S. V. Bolotin and D. V. Treshchev), § 7.2.1 on splitting of asymptotic surfaces conditions (with the participation of D. V. Treshchev). There are several other addenda. In this work we were greatly helped by S. V. Bolotin, M. B. Sevryuk, and D. V. Treshchev, to whom the authors are deeply grateful.

This English edition was prepared on the basis of the second Russian edition (Editorial URSS, 2002). The authors are deeply grateful to the translator E. I. Khukhro for fruitful collaboration.

Our text, of course, does not claim to be complete. Nor is it a textbook on theoretical mechanics: there are practically no detailed proofs in it. The main purpose of our work is to acquaint the reader with classical mechanics on the whole, both in its classical and most modern aspects. The reader can find the necessary proofs and more detailed information in the books and original research papers on this subject indicated at the end of this volume.

Contents

1	Basic Principles of Classical Mechanics	1
1.1	Newtonian Mechanics	1
1.1.1	Space, Time, Motion	1
1.1.2	Newton–Laplace Principle of Determinacy	2
1.1.3	Principle of Relativity	9
1.1.4	Principle of Relativity and Forces of Inertia	12
1.1.5	Basic Dynamical Quantities. Conservation Laws	15
1.2	Lagrangian Mechanics	17
1.2.1	Preliminary Remarks	17
1.2.2	Variations and Extremals	19
1.2.3	Lagrange’s Equations	21
1.2.4	Poincaré’s Equations	23
1.2.5	Motion with Constraints	26
1.3	Hamiltonian Mechanics	30
1.3.1	Symplectic Structures and Hamilton’s Equations	30
1.3.2	Generating Functions	33
1.3.3	Symplectic Structure of the Cotangent Bundle	34
1.3.4	The Problem of n Point Vortices	35
1.3.5	Action in the Phase Space	37
1.3.6	Integral Invariant	38
1.3.7	Applications to Dynamics of Ideal Fluid	40
1.4	Vakonomic Mechanics	41
1.4.1	Lagrange’s Problem	42
1.4.2	Vakonomic Mechanics	43
1.4.3	Principle of Determinacy	46
1.4.4	Hamilton’s Equations in Redundant Coordinates	47
1.5	Hamiltonian Formalism with Constraints	48
1.5.1	Dirac’s Problem	48
1.5.2	Duality	50
1.6	Realization of Constraints	51
1.6.1	Various Methods of Realization of Constraints	51

1.6.2	Holonomic Constraints	52
1.6.3	Anisotropic Friction	54
1.6.4	Adjoint Masses	55
1.6.5	Adjoint Masses and Anisotropic Friction	58
1.6.6	Small Masses	59
2	The n-Body Problem	61
2.1	The Two-Body Problem	61
2.1.1	Orbits	61
2.1.2	Anomalies	67
2.1.3	Collisions and Regularization	69
2.1.4	Geometry of Kepler's Problem	71
2.2	Collisions and Regularization	72
2.2.1	Necessary Condition for Stability	72
2.2.2	Simultaneous Collisions	73
2.2.3	Binary Collisions	74
2.2.4	Singularities of Solutions of the n -Body Problem	78
2.3	Particular Solutions	79
2.3.1	Central Configurations	79
2.3.2	Homographic Solutions	80
2.3.3	Effective Potential and Relative Equilibria	82
2.3.4	Periodic Solutions in the Case of Bodies of Equal Masses	82
2.4	Final Motions in the Three-Body Problem	83
2.4.1	Classification of the Final Motions According to Chazy	83
2.4.2	Symmetry of the Past and Future	84
2.5	Restricted Three-Body Problem	86
2.5.1	Equations of Motion. The Jacobi Integral	86
2.5.2	Relative Equilibria and Hill Regions	87
2.5.3	Hill's Problem	88
2.6	Ergodic Theorems of Celestial Mechanics	92
2.6.1	Stability in the Sense of Poisson	92
2.6.2	Probability of Capture	94
2.7	Dynamics in Spaces of Constant Curvature	95
2.7.1	Generalized Bertrand Problem	95
2.7.2	Kepler's Laws	96
2.7.3	Celestial Mechanics in Spaces of Constant Curvature	97
2.7.4	Potential Theory in Spaces of Constant Curvature	98
3	Symmetry Groups and Order Reduction	103
3.1	Symmetries and Linear Integrals	103
3.1.1	Nöther's Theorem	103
3.1.2	Symmetries in Non-Holonomic Mechanics	107
3.1.3	Symmetries in Vakonomic Mechanics	109
3.1.4	Symmetries in Hamiltonian Mechanics	110
3.2	Reduction of Systems with Symmetries	111

3.2.1	Order Reduction (Lagrangian Aspect)	111
3.2.2	Order Reduction (Hamiltonian Aspect)	116
3.2.3	Examples: Free Rotation of a Rigid Body and the Three-Body Problem.	122
3.3	Relative Equilibria and Bifurcation of Integral Manifolds	126
3.3.1	Relative Equilibria and Effective Potential	126
3.3.2	Integral Manifolds, Regions of Possible Motion, and Bifurcation Sets	128
3.3.3	The Bifurcation Set in the Planar Three-Body Problem	130
3.3.4	Bifurcation Sets and Integral Manifolds in the Problem of Rotation of a Heavy Rigid Body with a Fixed Point	131
4	Variational Principles and Methods	135
4.1	Geometry of Regions of Possible Motion	136
4.1.1	Principle of Stationary Abbreviated Action	136
4.1.2	Geometry of a Neighbourhood of the Boundary	139
4.1.3	Riemannian Geometry of Regions of Possible Motion with Boundary	140
4.2	Periodic Trajectories of Natural Mechanical Systems	145
4.2.1	Rotations and Librations	145
4.2.2	Librations in Non-Simply-Connected Regions of Possible Motion	147
4.2.3	Librations in Simply Connected Domains and Seifert's Conjecture	150
4.2.4	Periodic Oscillations of a Multi-Link Pendulum	153
4.3	Periodic Trajectories of Non-Reversible Systems	156
4.3.1	Systems with Gyroscopic Forces and Multivalued Functionals	156
4.3.2	Applications of the Generalized Poincaré Geometric Theorem	159
4.4	Asymptotic Solutions. Application to the Theory of Stability of Motion	161
4.4.1	Existence of Asymptotic Motions	162
4.4.2	Action Function in a Neighbourhood of an Unstable Equilibrium Position	165
4.4.3	Instability Theorem	166
4.4.4	Multi-Link Pendulum with Oscillating Point of Suspension	167
4.4.5	Homoclinic Motions Close to Chains of Homoclinic Motions	168
5	Integrable Systems and Integration Methods	171
5.1	Brief Survey of Various Approaches to Integrability of Hamiltonian Systems	171

5.1.1	Quadratures	171
5.1.2	Complete Integrability	174
5.1.3	Normal Forms	176
5.2	Completely Integrable Systems	179
5.2.1	Action–Angle Variables	179
5.2.2	Non-Commutative Sets of Integrals	183
5.2.3	Examples of Completely Integrable Systems	185
5.3	Some Methods of Integration of Hamiltonian Systems	191
5.3.1	Method of Separation of Variables	191
5.3.2	Method of L – A Pairs	197
5.4	Integrable Non-Holonomic Systems	199
5.4.1	Differential Equations with Invariant Measure	199
5.4.2	Some Solved Problems of Non-Holonomic Mechanics	202
6	Perturbation Theory for Integrable Systems	207
6.1	Averaging of Perturbations	207
6.1.1	Averaging Principle	207
6.1.2	Procedure for Eliminating Fast Variables. Non-Resonant Case	211
6.1.3	Procedure for Eliminating Fast Variables. Resonant Case	216
6.1.4	Averaging in Single-Frequency Systems	217
6.1.5	Averaging in Systems with Constant Frequencies	226
6.1.6	Averaging in Non-Resonant Domains	229
6.1.7	Effect of a Single Resonance	229
6.1.8	Averaging in Two-Frequency Systems	237
6.1.9	Averaging in Multi-Frequency Systems	242
6.1.10	Averaging at Separatrix Crossing	244
6.2	Averaging in Hamiltonian Systems	256
6.2.1	Application of the Averaging Principle	256
6.2.2	Procedures for Eliminating Fast Variables	265
6.3	KAM Theory	273
6.3.1	Unperturbed Motion. Non-Degeneracy Conditions	273
6.3.2	Invariant Tori of the Perturbed System	274
6.3.3	Systems with Two Degrees of Freedom	279
6.3.4	Diffusion of Slow Variables in Multidimensional Systems and its Exponential Estimate	286
6.3.5	Diffusion without Exponentially Small Effects	292
6.3.6	Variants of the Theorem on Invariant Tori	294
6.3.7	KAM Theory for Lower-Dimensional Tori	297
6.3.8	Variational Principle for Invariant Tori. Cantori	307
6.3.9	Applications of KAM Theory	311
6.4	Adiabatic Invariants	314
6.4.1	Adiabatic Invariance of the Action Variable in Single-Frequency Systems	314

6.4.2	Adiabatic Invariants of Multi-Frequency Hamiltonian Systems	323
6.4.3	Adiabatic Phases	326
6.4.4	Procedure for Eliminating Fast Variables. Conservation Time of Adiabatic Invariants	332
6.4.5	Accuracy of Conservation of Adiabatic Invariants	334
6.4.6	Perpetual Conservation of Adiabatic Invariants	340
6.4.7	Adiabatic Invariants in Systems with Separatrix Crossings	342
7	Non-Integrable Systems	351
7.1	Nearly Integrable Hamiltonian Systems	351
7.1.1	The Poincaré Method	352
7.1.2	Birth of Isolated Periodic Solutions as an Obstruction to Integrability	354
7.1.3	Applications of Poincaré’s Method	358
7.2	Splitting of Asymptotic Surfaces	360
7.2.1	Splitting Conditions. The Poincaré Integral	360
7.2.2	Splitting of Asymptotic Surfaces as an Obstruction to Integrability	366
7.2.3	Some Applications	370
7.3	Quasi-Random Oscillations	373
7.3.1	Poincaré Return Map	375
7.3.2	Symbolic Dynamics	378
7.3.3	Absence of Analytic Integrals	380
7.4	Non-Integrability in a Neighbourhood of an Equilibrium Position (Siegel’s Method)	381
7.5	Branching of Solutions and Absence of Single-Valued Integrals	385
7.5.1	Branching of Solutions as Obstruction to Integrability . .	385
7.5.2	Monodromy Groups of Hamiltonian Systems with Single-Valued Integrals	388
7.6	Topological and Geometrical Obstructions to Complete Integrability of Natural Systems	391
7.6.1	Topology of Configuration Spaces of Integrable Systems	392
7.6.2	Geometrical Obstructions to Integrability	394
7.6.3	Multidimensional Case	396
7.6.4	Ergodic Properties of Dynamical Systems with Multivalued Hamiltonians	396
8	Theory of Small Oscillations	401
8.1	Linearization	401
8.2	Normal Forms of Linear Oscillations	402
8.2.1	Normal Form of a Linear Natural Lagrangian System . .	402

8.2.2	Rayleigh–Fisher–Courant Theorems on the Behaviour of Characteristic Frequencies when Rigidity Increases or Constraints are Imposed	403
8.2.3	Normal Forms of Quadratic Hamiltonians	404
8.3	Normal Forms of Hamiltonian Systems near an Equilibrium Position	406
8.3.1	Reduction to Normal Form	406
8.3.2	Phase Portraits of Systems with Two Degrees of Freedom in a Neighbourhood of an Equilibrium Position at a Resonance	409
8.3.3	Stability of Equilibria of Hamiltonian Systems with Two Degrees of Freedom at Resonances	416
8.4	Normal Forms of Hamiltonian Systems near Closed Trajectories	417
8.4.1	Reduction to Equilibrium of a System with Periodic Coefficients	417
8.4.2	Reduction of a System with Periodic Coefficients to Normal Form	418
8.4.3	Phase Portraits of Systems with Two Degrees of Freedom near a Closed Trajectory at a Resonance	419
8.5	Stability of Equilibria in Conservative Fields	422
8.5.1	Lagrange–Dirichlet Theorem	422
8.5.2	Influence of Dissipative Forces	426
8.5.3	Influence of Gyroscopic Forces	427
9	Tensor Invariants of Equations of Dynamics	431
9.1	Tensor Invariants	431
9.1.1	Frozen-in Direction Fields	431
9.1.2	Integral Invariants	433
9.1.3	Poincaré–Cartan Integral Invariant	436
9.2	Invariant Volume Forms	438
9.2.1	Liouville’s Equation	438
9.2.2	Condition for the Existence of an Invariant Measure	439
9.2.3	Application of the Method of Small Parameter	442
9.3	Tensor Invariants and the Problem of Small Denominators	445
9.3.1	Absence of New Linear Integral Invariants and Frozen-in Direction Fields	445
9.3.2	Application to Hamiltonian Systems	446
9.3.3	Application to Stationary Flows of a Viscous Fluid	449
9.4	Systems on Three-Dimensional Manifolds	451
9.5	Integral Invariants of the Second Order and Multivalued Integrals	455
9.6	Tensor Invariants of Quasi-Homogeneous Systems	457
9.6.1	Kovalevskaya–Lyapunov Method	457
9.6.2	Conditions for the Existence of Tensor Invariants	459

9.7	General Vortex Theory	461
9.7.1	Lamb's Equation	461
9.7.2	Multidimensional Hydrodynamics	463
9.7.3	Invariant Volume Forms for Lamb's Equations	465
Recommended Reading		471
Bibliography		475
Index of Names		507
Subject Index		511

Basic Principles of Classical Mechanics

For describing the motion of a mechanical system various mathematical models are used based on different “principles” – laws of motion. In this chapter we list the basic objects and principles of classical dynamics. The simplest and most important model of the motion of real bodies is Newtonian mechanics, which describes the motion of a free system of interacting points in three-dimensional Euclidean space. In §1.6 we discuss the suitability of applying Newtonian mechanics when dealing with complicated models of motion.

1.1 Newtonian Mechanics

1.1.1 Space, Time, Motion

The space where the motion takes place is three-dimensional and Euclidean with a fixed orientation. We shall denote it by E^3 . We fix some point $o \in E^3$ called the “origin of reference”. Then the position of every point s in E^3 is uniquely determined by its position vector $\vec{os} = \mathbf{r}$ (whose initial point is o and end point is s). The set of all position vectors forms the three-dimensional vector space \mathbb{R}^3 , which is equipped with the scalar product $\langle \cdot, \cdot \rangle$.

Time is one-dimensional; it is denoted by t throughout. The set $\mathbb{R} = \{t\}$ is called the *time axis*.

A *motion* (or *path*) of the point s is a smooth map $\Delta \rightarrow E^3$, where Δ is an interval of the time axis. We say that the motion is defined on the interval Δ . If the origin (point o) is fixed, then every motion is uniquely determined by a smooth vector-function $\mathbf{r}: \Delta \rightarrow \mathbb{R}^3$.

The image of the interval Δ under the map $t \mapsto \mathbf{r}(t)$ is called the *trajectory* or *orbit of the point s* .

The *velocity* \mathbf{v} of the point s at an instant $t \in \Delta$ is by definition the derivative $d\mathbf{r}/dt = \dot{\mathbf{r}}(t) \in \mathbb{R}^3$. Clearly the velocity is independent of the choice of the origin.

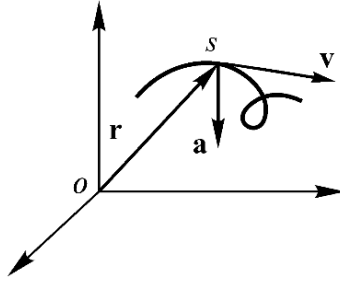

Fig. 1.1.

The *acceleration* of the point is by definition the vector $\mathbf{a} = \dot{\mathbf{v}} = \ddot{\mathbf{r}} \in \mathbb{R}^3$. The velocity and acceleration are usually depicted as vectors with initial point at the point s (see Fig. 1.1).

The set E^3 is also called the *configuration space* of the point s . The pair (s, \mathbf{v}) is called the *state* of the point, and the set $E^3 \times \mathbb{R}^3\{\mathbf{v}\}$, the *phase* (or *state*) *space*.

Now consider a more general case when there are n points s_1, \dots, s_n moving in the space E^3 . The set $E^{3n} = E^3\{s_1\} \times \dots \times E^3\{s_n\}$ is called the *configuration space* of this “free” system. If it is necessary to exclude collisions of the points, then E^{3n} must be diminished by removing from it the union of diagonals

$$\Delta = \bigcup_{i < j} \{s_i = s_j\}.$$

Let $(\mathbf{r}_1, \dots, \mathbf{r}_n) = \mathbf{r} \in \mathbb{R}^{3n}$ be the position vectors of the points s_1, \dots, s_n . A motion of the free system is given by smooth vector-functions $\mathbf{r}(t) = (\mathbf{r}_1(t), \dots, \mathbf{r}_n(t))$. We define in similar fashion the velocity

$$\mathbf{v} = \dot{\mathbf{r}} = (\dot{\mathbf{r}}_1, \dots, \dot{\mathbf{r}}_n) = (\mathbf{v}_1, \dots, \mathbf{v}_n) \in \mathbb{R}^{3n}$$

and the acceleration

$$\mathbf{a} = \ddot{\mathbf{r}} = (\ddot{\mathbf{r}}_1, \dots, \ddot{\mathbf{r}}_n) = (\mathbf{a}_1, \dots, \mathbf{a}_n) \in \mathbb{R}^{3n}.$$

The set $E^{3n} \times \mathbb{R}^{3n}\{\mathbf{v}\}$ is called the *phase* (or *state*) *space*, and the pair (s, \mathbf{v}) , the *state* of the system.

1.1.2 Newton–Laplace Principle of Determinacy

This principle (which is an experimental fact) asserts that the state of the system at any fixed moment of time uniquely determines all of its motion (both in the future and in the past).

Suppose that we know the state of the system $(\mathbf{r}_0, \mathbf{v}_0)$ at an instant t_0 . Then, according to the principle of determinacy, we know the motion $\mathbf{r}(t)$,

$t \in \Delta \subset \mathbb{R}$; $\mathbf{r}(t_0) = \mathbf{r}_0$, $\dot{\mathbf{r}}(t_0) = \dot{\mathbf{r}}_0 = \mathbf{v}_0$. In particular, we can calculate the acceleration $\ddot{\mathbf{r}}$ at the instant $t = t_0$.¹ Then $\ddot{\mathbf{r}}(t_0) = \mathbf{f}(t_0, \mathbf{r}_0, \dot{\mathbf{r}}_0)$, where \mathbf{f} is some function whose existence follows from the Newton–Laplace principle. Since the time t_0 can be chosen arbitrarily, we have the equation

$$\ddot{\mathbf{r}} = \mathbf{f}(t, \mathbf{r}, \dot{\mathbf{r}})$$

for all t .

This differential equation is called the *equation of motion* or *Newton’s equation*. The existence of Newton’s equation (with a smooth vector-function $\mathbf{f}: \mathbb{R}\{t\} \times \mathbb{R}^{3n}\{\mathbf{r}\} \times \mathbb{R}^{3n}\{\dot{\mathbf{r}}\} \rightarrow \mathbb{R}^{3n}$) is equivalent to the principle of determinacy. This follows from the existence and uniqueness theorem in the theory of differential equations. The function \mathbf{f} in Newton’s equations is usually determined in experiments. The definition of a mechanical system includes specifying this function.

We now consider examples of Newton’s equations.

a) The equation of a point in free fall in vacuum near the surface of the Earth (obtained experimentally by Galileo) has the form $\ddot{\mathbf{r}} = -g\mathbf{e}_z$, where $g \approx 9.8 \text{ m/s}^2$ (the acceleration of gravity) and \mathbf{e}_z is the vertical unit vector. The trajectory of a falling point is a parabola.

b) Hooke showed that the equation of small oscillations of a body attached to the end of an elastic spring has the form $\ddot{x} = -\alpha x$, $\alpha > 0$. The constant coefficient α depends on the choice of the body and spring. This mechanical system is called a *harmonic oscillator* (see Fig. 1.2).

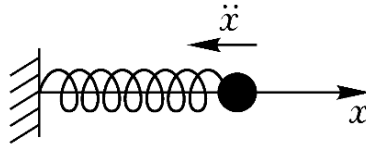

Fig. 1.2. Harmonic oscillator

It turned out that in experiments, rather than finding the acceleration \mathbf{f} on the right-hand side of Newton’s equations, it is more convenient to determine the product $m\mathbf{f} = \mathbf{F}$, where m is some positive number called the mass of the point (an instructive discussion of the physical meaning of the notion of mass can be found in [601, 401, 310]). For example, in Hooke’s experiments the constant $m\alpha = c$ depends on the properties of the elastic spring, but not on the choice of the body. This constant is called the coefficient of elasticity.

The pair (s, m) (or (\mathbf{r}, m) , where \mathbf{r} is the position vector of the point s) is called a *material point* of mass m . In what follows we shall often denote a point s and its mass m by one and the same symbol m . If a system of material

¹ We assume that all the functions occurring in dynamics are smooth.

points consists of n points with masses m_1, \dots, m_n , then Newton's equations

$$\ddot{\mathbf{r}}_i = \mathbf{f}_i(t, \mathbf{r}_1, \dots, \mathbf{r}_n, \dot{\mathbf{r}}_1, \dots, \dot{\mathbf{r}}_n), \quad 1 \leq i \leq n,$$

can be rewritten as

$$m_i \ddot{\mathbf{r}}_i = \mathbf{F}_i(t, \mathbf{r}, \dot{\mathbf{r}}), \quad 1 \leq i \leq n.$$

The vector $\mathbf{F}_i = m_i \mathbf{f}_i$ is called the *force* acting on the point m_i . "The word *force* does not occur in the principles of Dynamics, as we have just presented it. One can, in effect, bypass it."² The last equations are also called Newton's equations.

c) As established by Newton (in development of earlier ideas of Kepler), if there are n material points $(\mathbf{r}_1, m_1), \dots, (\mathbf{r}_n, m_n)$ in space, then the i th point is acted upon by the force $\mathbf{F}_i = \sum_{i \neq j} \mathbf{F}_{ij}$, where

$$\mathbf{F}_{kl} = -\frac{\gamma m_k m_l}{|\mathbf{r}_{kl}|^3} \mathbf{r}_{kl}, \quad \mathbf{r}_{kl} = \mathbf{r}_l - \mathbf{r}_k, \quad \gamma = \text{const} > 0.$$

This is the *law of universal gravitation*.

d) When a body is moving fast through the air, the resistance force is proportional to the square of the velocity (Stokes' law). Hence the equation of a body falling in the air has the form $m\ddot{z} = mg - c\dot{z}^2$, $c > 0$. It turns out that there always exists the limit $\lim_{t \rightarrow \infty} v(t)$ equal to $\sqrt{mg/c}$ and independent of the initial state.

When a body moves slowly in a resisting medium, the friction force is a linear function of the velocity. The idea of approximating the resistance force by the formula

$$F = -\alpha v - cv^2, \quad \alpha, c = \text{const} > 0,$$

goes back to Huygens; this formula takes into account both limiting cases. The vertical fall of a heavy body is described by the equation

$$m\ddot{z} = mg - \alpha\dot{z} - c\dot{z}^2.$$

It is easy to show that

$$\lim_{t \rightarrow \infty} v(t) = \frac{\sqrt{\alpha^2 + 4mgc} - \alpha}{2c}.$$

For $\alpha > 0$ this quantity is clearly less than $\sqrt{mg/c}$.

² Appell ([5], p.94). In Newton's time the word "force" (vis in Latin) was used for various objects, for example, the acceleration of a point. Leibnitz called the product of the mass of a point and the square of its velocity vis viva (live force). The modern term "force" corresponds to Newton's vis motrix (accelerating force).

Suppose that a material point (\mathbf{r}, m) is moving under the action of a force \mathbf{F} . Let

$$\mathbf{r} = x\mathbf{e}_x + y\mathbf{e}_y + z\mathbf{e}_z, \quad \mathbf{F} = X\mathbf{e}_x + Y\mathbf{e}_y + Z\mathbf{e}_z,$$

where $\mathbf{e}_x, \mathbf{e}_y, \mathbf{e}_z$ is a fixed orthonormal frame of reference. Then Newton's equation $m\ddot{\mathbf{r}} = \mathbf{F}$ is equivalent to the three scalar equations

$$m\ddot{x} = X, \quad m\ddot{y} = Y, \quad m\ddot{z} = Z.$$

This self-evident trick, which was suggested by Maclaurin for describing the motion of a point in three-dimensional space, was not evident to the classics. Before Maclaurin the so-called *natural equations of motion* were usually used.

Let s be the natural parameter along the trajectory of motion of the point. The trajectory is given by the correspondence $s \mapsto \mathbf{r}(s)$. The unit vector $\boldsymbol{\tau} = \mathbf{r}'$ (prime denotes differentiation with respect to the natural parameter) is tangent to the trajectory. The vector

$$\frac{\mathbf{r}''}{|\mathbf{r}''|} = \boldsymbol{\nu}$$

defines the normal, and the vector $\boldsymbol{\beta} = \boldsymbol{\tau} \times \boldsymbol{\nu}$, the binormal, to the trajectory. The vectors $\boldsymbol{\tau}, \boldsymbol{\nu}, \boldsymbol{\beta}$ are functions of s . Their evolution is described by the *Frenet formulae*, which are well-known in geometry:

$$\begin{aligned} \boldsymbol{\tau}' &= k\boldsymbol{\nu} \\ \boldsymbol{\nu}' &= -k\boldsymbol{\tau} + \varkappa\boldsymbol{\beta} \\ \boldsymbol{\beta}' &= -\varkappa\boldsymbol{\nu}. \end{aligned}$$

The quantities k and \varkappa depend on the point of the trajectory; they are called the curvature and the torsion of the trajectory at this point. The motion of the point $\mathbf{r}: \Delta \rightarrow E^3$ can be represented as the composition $t \mapsto \mathbf{r}(s(t))$. Then $\mathbf{v} = \mathbf{r}'\dot{s}$ and $\mathbf{a} = \mathbf{r}''\dot{s}^2 + \mathbf{r}'\ddot{s}$. Since $\mathbf{r}' = \boldsymbol{\tau}$ and $\mathbf{r}'' = k\boldsymbol{\nu}$ (Frenet formula), we have

$$\mathbf{a} = \ddot{s}\boldsymbol{\tau} + k\dot{s}^2\boldsymbol{\nu}.$$

This formula was essentially known already to Huygens. Multiplying it by m and setting $\mathbf{F} = F_\tau\boldsymbol{\tau} + F_\nu\boldsymbol{\nu} + F_\beta\boldsymbol{\beta}$ we arrive at the natural equations of motion

$$m\ddot{s} = F_\tau, \quad mk\dot{s}^2 = F_\nu, \quad F_\beta = 0. \tag{1.1}$$

Since s is the arc length, $\dot{s} = v$ is the speed of motion of the point. Then the first two equations (1.1) are usually written in the form

$$m\dot{v} = F_\tau, \quad \frac{mv^2}{\rho} = F_\nu, \tag{1.2}$$

where $\rho = k^{-1}$ is the radius of curvature of the trajectory.

We now consider some more examples of application of Newton's equation.

e) It is known [4] that a charge e placed in an electro-magnetic field is acted upon by the force

$$\mathbf{F} = e \left(\mathbf{E} + \frac{1}{c} (\mathbf{v} \times \mathbf{H}) \right),$$

where \mathbf{E} , \mathbf{H} are the strengths of the electric and magnetic fields (they satisfy the Maxwell system of equations) and c is the speed of light. This force is called the Lorentz force.

Consider a special case of motion where the electric field is absent. Then the Lorentz force is orthogonal to the velocity of the charge and therefore $F_\tau = 0$ in equations (1.2). Consequently, the charge is moving with constant speed.

Suppose in addition that the magnetic field is homogeneous ($\mathbf{H} = \text{const}$), and at the initial instant the velocity of the charge is orthogonal to the magnetic force lines. Then, as can be easily seen, the trajectory of the charge is a planar curve orthogonal to \mathbf{H} . Since

$$|F_\nu| = \frac{e|\mathbf{v}|H}{c}, \quad \text{where } H = |\mathbf{H}|,$$

it follows from the second of equations (1.2) that the charge is moving along a circle of radius

$$\rho = \frac{mvc}{eH}.$$

This quantity is called the *Larmor radius*.

More interesting is the problem of motion of a charge in the field of a magnetic pole, which was considered by Poincaré. If $\mathbf{E} = 0$, then the magnetic field is stationary and satisfies the Maxwell equations

$$\text{curl } \mathbf{H} = 0, \quad \text{div } \mathbf{H} = 0.$$

It follows from the first equation that \mathbf{H} is locally conservative ($\mathbf{H} = \text{grad } U$), and the second equation shows that the potential is a harmonic function ($\Delta U = 0$, where Δ is the Laplace operator). Poincaré considered the only potential depending only on the distance:

$$U = \frac{k}{|\mathbf{r}|}, \quad k = \text{const}.$$

In this case,

$$\mathbf{H} = -\frac{k\mathbf{r}}{|\mathbf{r}|^3}$$

and therefore the equation of motion of the charge has the form

$$\mu \ddot{\mathbf{r}} = \frac{\mathbf{r} \times \dot{\mathbf{r}}}{|\mathbf{r}|^3}, \quad \mu = \frac{mc}{ek}.$$

It is equivalent to the following relation:

$$\mu(\mathbf{r} \times \dot{\mathbf{r}}) = -\frac{\mathbf{r}}{|\mathbf{r}|} + \mathbf{a}, \quad \mathbf{a} = \text{const.}$$

Consequently,

$$(\mathbf{a}, \mathbf{r}) = |\mathbf{r}|. \tag{1.3}$$

This is the equation of a cone of revolution whose symmetry axis is parallel to the vector \mathbf{a} . We demonstrate that the charged particle moves along the geodesics on this cone. Indeed, \mathbf{r} and $\dot{\mathbf{r}}$ are tangent to the cone (1.3). Consequently, the acceleration vector is orthogonal to this cone. Since the speed of motion is constant, by Huygens' formula the normal to the trajectory coincides with the normal to the cone. Therefore the trajectories are geodesics.

This result of Poincaré explains the phenomenon of cathode rays being drawn in by a magnetic pole discovered in 1895 by Birkeland [501].

f) We consider in addition the problem of external ballistics: a material point (\mathbf{r}, m) is moving along a curvilinear orbit near the surface of the Earth experiencing the air resistance. We assume that the resistance force \mathbf{F} has opposite direction to the velocity and its magnitude can be represented in the form

$$|\mathbf{F}| = mg\varphi(v),$$

where φ is a monotonically increasing function such that $\varphi(0) = 0$ and $\varphi(v) \rightarrow +\infty$ as $v \rightarrow +\infty$.

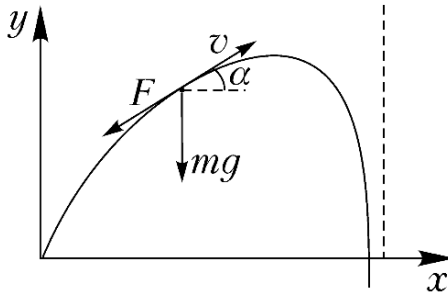

Fig. 1.3. Ballistic trajectory

Since at every moment of time the vectors of the velocity of the point, its weight, and the resistance force lie in the same vertical plane, the trajectory of the point is a planar curve. In the plane of the orbit we introduce Cartesian coordinates x, y such that the y -axis is directed vertically upwards. Let α be the angle between the velocity of the point \mathbf{v} and the horizon (Fig. 1.3). The first of equations (1.2) gives the relation

$$\dot{v} = -g[\sin \alpha + \varphi(v)]. \tag{1.4}$$

We now make use of the second equation in (1.2). First of all we observe that $\rho = -ds/d\alpha$. The sign “-” shows that the angle α decreases as s increases. Taking the projection of the gravitational force onto the normal we arrive at the second relation

$$v\dot{\alpha} = -g \cos \alpha. \tag{1.5}$$

The phase portrait of the closed system of differential equations (1.4) and (1.5) is depicted in Fig. 1.4. All the phase trajectories approach arbitrarily closely the point $\alpha = -\pi/2, v = v_0$, where v_0 is the unique positive root of the equation $\varphi(v) = 1$. This point corresponds to the vertical fall of the body with constant velocity (as in example d).

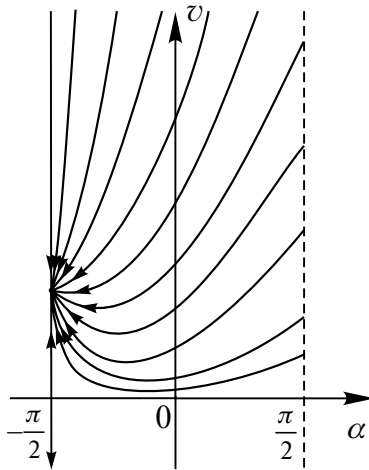

Fig. 1.4. The phase portrait of the ballistic problem

We demonstrate that the trajectory has a vertical asymptote when continued infinitely (as depicted in Fig. 1.3). Indeed, the x -coordinate is determined by the formula

$$x(t) = \int_{t_0}^t v \cos \alpha dt.$$

We need to show that the corresponding improper integral (when $t = \infty$) converges. For that we pass to a new integration variable α and use (1.5):

$$x = \frac{1}{g} \int_{-\pi/2}^{\alpha_0} v^2 d\alpha.$$

Since the speed is bounded, this integral has a finite value.

For some laws of resistance, the system of equations (1.4)–(1.5) can be solved explicitly. One of such laws was found already by Legendre:

$$\varphi(v) = cv^\gamma, \quad c, \gamma = \text{const} > 0.$$

The substitution $u = v^{-\gamma}$ reduces this problem to integrating the single linear differential equation

$$\frac{du}{d\alpha} + \gamma u \tan \alpha + \gamma c \cos^{-1} \alpha = 0.$$

This equation can be easily solved by the method of variation of parameters.

One can find references to other results devoted to the exact integration of equations (1.4)–(1.5), for example, in the book [5].

The principle of determinacy holds also in relativistic mechanics. The difference between classical Newtonian mechanics and relativistic mechanics is in *Galileo's principle of relativity*.

1.1.3 Principle of Relativity

The direct product $E^3 \times \mathbb{R}\{t\}$ (space–time) has the natural structure of an affine space. The *Galilean group* is by definition the group of all affine transformations of $E^3 \times \mathbb{R}$ that preserve time intervals and are isometries of the space E^3 for any fixed $t \in \mathbb{R}$. Thus, if $g: (s, t) \rightarrow (s', t')$ is a Galilean transformation, then

- 1) $t_\alpha - t_\beta = t'_\alpha - t'_\beta$,
- 2) if $t_\alpha = t_\beta$, then $|s_\alpha - s_\beta| = |s'_\alpha - s'_\beta|$.

The Galilean group obviously acts on $\mathbb{R}^3\{\mathbf{r}\} \times \mathbb{R}\{t\}$. We give three examples of Galilean transformations of this space. First, uniform motion with constant velocity \mathbf{v} :

$$g_1(\mathbf{r}, t) = (\mathbf{r} + \mathbf{v}t, t).$$

Next, translation of the origin in space–time:

$$g_2(\mathbf{r}, t) = (\mathbf{r} + \mathbf{x}, t + \alpha).$$

Finally, rotation of the coordinate axes:

$$g_3(\mathbf{r}, t) = (G\mathbf{r}, t),$$

where $G: \mathbb{R}^3 \rightarrow \mathbb{R}^3$ is an orthogonal transformation.

Proposition 1.1. *Every Galilean transformation $g: \mathbb{R}^3 \times \mathbb{R} \rightarrow \mathbb{R}^3 \times \mathbb{R}$ can be uniquely represented as a composition $g_1g_2g_3$.*

We shall find an explicit form of Galilean transformations, from which Proposition 1.1 will immediately follow. For that we consider an affine transformation of $E^4 = E^3 \times \mathbb{R}$ of the general form:

$$\mathbf{x} = A\mathbf{x}' + \mathbf{v}t' + \mathbf{a}, \quad t = \langle \mathbf{l}, \mathbf{x}' \rangle + kt' + s.$$

Here A is a 3×3 matrix; \mathbf{v} , \mathbf{a} , and \mathbf{l} are vectors in three-dimensional Euclidean space; k and s are real numbers.

First we show that $l = 0$ and $k = 1$ for Galilean transformations. Indeed, using property 1) we obtain the equality

$$t_1 - t_2 = \langle \mathbf{l}, \mathbf{x}'_1 - \mathbf{x}'_2 \rangle + k(t'_1 - t'_2) = t'_1 - t'_2 \quad (1.6)$$

that holds for all pairs of points (\mathbf{x}'_1, t'_1) and (\mathbf{x}'_2, t'_2) in E_4 . Setting $t'_1 = t'_2$ we obtain that $\langle \mathbf{l}, \mathbf{x}' \rangle = 0$ for all vectors \mathbf{x}' , whence $\mathbf{l} = 0$. But then (1.6) implies $k = 1$.

We now show that A is an orthogonal matrix. For that we set $t_1 = t_2$ (then $t'_1 = t'_2$) and use property 2):

$$|\mathbf{x}_1 - \mathbf{x}_2| = |A\mathbf{x}'_1 - A\mathbf{x}'_2| = |A(\mathbf{x}'_1 - \mathbf{x}'_2)| = |\mathbf{x}'_1 - \mathbf{x}'_2|$$

for any \mathbf{x}'_1 and \mathbf{x}'_2 . Consequently, the matrix A is orthogonal.

Thus, we have found the general form of Galilean transformations:

$$x = A\mathbf{x}' + \mathbf{v}t' + \mathbf{a}, \quad t = t' + s; \quad A \in O(3), \quad \mathbf{v}, \mathbf{a} \in \mathbb{R}^3, \quad s \in \mathbb{R}. \quad (1.7)$$

Since the orthogonal matrices form a three-parameter family, Galilean transformations of the general form involve 10 independent parameters.

We introduce in E^3 a “fixed” frame of reference by fixing a point $o \in E^3$ and choosing three mutually perpendicular axes. Every element of the Galilean group transforms this frame into another frame, which moves uniformly and rectilinearly with respect to the first frame. Such frames are said to be *inertial*.

In practice a frame of reference attached to the stars is chosen for a “fixed” frame. But if the motion of the stars themselves is taken into account, then a more precise definition of a frame is established using statistical averages. However, a frame of reference attached to the Earth serves as a sufficient approximation of an inertial frame for many practical problems.

The action of the Galilean group on $E^3 \times \mathbb{R}$ can be extended to the action on $E^3 \times \dots \times E^3 \times \mathbb{R}$ by the rule: if $g: (s, t) \rightarrow (s', t')$, then $g(s_1, \dots, s_n, t) = (s'_1, \dots, s'_n, t')$.

The Galileo–Newton *principle of relativity* asserts that Newton’s equations are invariant under the Galilean transformation group in an inertial frame of reference.

This principle (which has empirical origin) imposes a number of conditions on the form of the right-hand side of Newton’s equation written in an inertial frame of reference. Since among Galilean transformations there are translations of the time axis, the forces are independent of t :

$$m_i \ddot{\mathbf{r}}_i = \mathbf{F}_i(\mathbf{r}, \dot{\mathbf{r}}), \quad 1 \leq i \leq n.$$

Forces depending on time can only appear in Newtonian mechanics in simplified models of motion.

Among Galilean transformations there are translations in three-dimensional space E^3 . Since E^3 is homogeneous, it follows that in inertial frames forces depend only on the relative coordinates $\mathbf{r}_k - \mathbf{r}_l$. Since Newton's equations are invariant under the subgroup of uniform motions g_1 , it follows that forces also depend only on the relative velocities of the points:

$$m_i \ddot{\mathbf{r}}_i = \mathbf{F}_i(\mathbf{r}_k - \mathbf{r}_l, \dot{\mathbf{r}}_k - \dot{\mathbf{r}}_i), \quad i, k, l = 1, \dots, n. \quad (1.8)$$

The isotropy of E^3 (invariance under the subgroup of rotations g_3) implies the relation

$$\mathbf{F}(G\mathbf{r}, G\dot{\mathbf{r}}) = G\mathbf{F}(\mathbf{r}, \dot{\mathbf{r}}). \quad (1.9)$$

If a mechanical system consists of a single point, then this point moves uniformly and rectilinearly with respect to any inertial frame.³ Indeed, in this case the force \mathbf{F} is independent of $t, \mathbf{r}, \dot{\mathbf{r}}$ and is invariant under rotations. Consequently, $\mathbf{F} \equiv 0$.

If a system consists of two points, then the forces \mathbf{F}_1 and \mathbf{F}_2 applied to the points are directed along the straight line connecting the points. Moreover, according to the *principle of equality of action and reaction* it is assumed that $\mathbf{F}_1 = -\mathbf{F}_2$. This experimental principle, which is independent of the relativity principle, leads to the general notions of *forces of interaction* and of a *closed mechanical system*. A system of n material points (\mathbf{r}_i, m_i) , $1 \leq i \leq n$, acted upon by forces \mathbf{F}_i is said to be closed if

$$\mathbf{F}_i = \sum_{\substack{i \neq j \\ 1 \leq j \leq n}} \mathbf{F}_{ij}, \quad \mathbf{F}_{kl} = -\mathbf{F}_{lk}.$$

The vector \mathbf{F}_{ij} is called the force with which the j th point acts on the i th one. An important example of interaction is the universal gravitation.

If a system consists of three material points, then it follows from the relativity principle that the forces acting on the points lie in the plane of these points.

Among the laws of motion given as examples in § 1.1.2 only the universal gravitation is Galilean-invariant. However, if in a system of gravitating points the mass of one of them is infinitesimally small (say, a speck of dust in the Solar System), then its influence on the motion of the other points is negligible. The "restricted" problem thus obtained (which has important applications in astronomy) no longer satisfies Galileo's principle of relativity. Many laws of motion occurring in Newtonian mechanics that are not Galilean-invariant are obtained from invariant laws of motion by making similar simplifying assumptions.

³ This is the *Galileo-Newton law of inertia*. Thus, the law of inertia is a consequence of the principles of determinacy and relativity.

1.1.4 Principle of Relativity and Forces of Inertia

According to §1.1.3 in an inertial frame of reference the law of motion has the form (1.8) and relation (1.9) holds. We now pass to a non-inertial frame by the change of variables

$$t \mapsto t, \quad \mathbf{x} = B(t)\mathbf{z} + \mathbf{b}(t), \quad (1.10)$$

where \mathbf{z} is the position vector of the material point in the new frame, $B(t) \in O(3)$ for all values of t , and \mathbf{b} is the position vector of the origin of the non-inertial frame.

By differentiating relation (1.10) with respect to t we obtain the formulae

$$\dot{\mathbf{x}} = \dot{B}\mathbf{z} + B\dot{\mathbf{z}} + \dot{\mathbf{b}}, \quad \ddot{\mathbf{x}} = \ddot{B}\mathbf{z} + 2\dot{B}\dot{\mathbf{z}} + B\ddot{\mathbf{z}} + \ddot{\mathbf{b}}. \quad (1.11)$$

Substituting (1.10) and (1.11) into (1.8) we obtain the equation of motion in the new frame:

$$m_i(\ddot{B}\mathbf{z}_i + 2\dot{B}\dot{\mathbf{z}}_i + B\ddot{\mathbf{z}}_i + \ddot{\mathbf{b}}) = \mathbf{F}_i(B(\mathbf{z}_k - \mathbf{z}_j), \dot{B}(\mathbf{z}_k - \mathbf{z}_j) + B(\dot{\mathbf{z}}_k - \dot{\mathbf{z}}_j)). \quad (1.12)$$

Since $B \in O(3)$, according to (1.9) we have

$$B^{-1}\mathbf{F}_i(\mathbf{x}_k, \dot{\mathbf{x}}_k) = \mathbf{F}_i(B^{-1}\mathbf{x}_k, B^{-1}\dot{\mathbf{x}}_k).$$

Consequently, equations (1.12) can be represented in the form

$$\begin{aligned} m_i\ddot{\mathbf{z}}_i &= \mathbf{F}_i(\mathbf{z}_k - \mathbf{z}_j, B^{-1}\dot{B}(\mathbf{z}_k - \mathbf{z}_j) + \dot{\mathbf{z}}_k - \dot{\mathbf{z}}_j) \\ &\quad - m_i B^{-1}\ddot{B}\mathbf{z}_i - 2m_i B^{-1}\dot{B}\dot{\mathbf{z}}_i - m_i B^{-1}\ddot{\mathbf{b}}. \end{aligned} \quad (1.13)$$

Thus, the passage to a non-inertial frame gives rise to the additional forces

$$\Phi_i = -m_i(B^{-1}\ddot{B}\mathbf{z}_i + B^{-1}\ddot{\mathbf{b}}) \quad \text{and} \quad \Psi_i = -2m_i B^{-1}\dot{B}\dot{\mathbf{z}}_i, \quad (1.14)$$

which are called the *forces of inertia*. These expressions can be transformed to a more clear and traditional form.

First of all we observe that the matrix $B^{-1}\dot{B}$ is skew-symmetric. Indeed, by the definition of orthogonal matrices we have

$$B^T B = E.$$

Here B^T denotes the transpose of B and E is the identity 3×3 matrix. By differentiating this relation with respect to t we obtain

$$\dot{B}^T B + B^T \dot{B} = 0 \quad \text{or} \quad (B^{-1}\dot{B})^T + B^{-1}\dot{B} = 0,$$

as required.

We set

$$B^{-1}\dot{B} = \begin{pmatrix} 0 & -\omega_3 & \omega_2 \\ \omega_3 & 0 & -\omega_1 \\ -\omega_2 & \omega_1 & 0 \end{pmatrix}. \quad (1.15)$$

It is easy to verify that

$$B^{-1}\dot{B}\mathbf{z} = \boldsymbol{\omega} \times \mathbf{z},$$

where the vector $\boldsymbol{\omega}$ has components $\omega_1, \omega_2, \omega_3$. The vector $\boldsymbol{\omega}$ is called the *angular velocity* of the moving frame. One should bear in mind that the direction of the vector $\boldsymbol{\omega}$ depends essentially on the chosen orientation of Euclidean space, while the vector $\boldsymbol{\omega}$ itself is independent of a (positively oriented) Cartesian coordinate system. Such vectors are often called *axial* vectors.

Thus, formula (1.14) for the force $\boldsymbol{\Psi}$ can be rewritten in the vector form:

$$\boldsymbol{\Psi}_i = -2m_i(\boldsymbol{\omega} \times \dot{\mathbf{z}}_i).$$

Here $\dot{\mathbf{z}}_i$ is the relative velocity of the point m_i (the velocity of motion in the moving frame). This formula was first obtained by Coriolis; the force $\boldsymbol{\Psi}$ is called the *Coriolis force*.

We set $\boldsymbol{\varepsilon} = \dot{\boldsymbol{\omega}}$, $\mathbf{w} = B^{-1}\ddot{\mathbf{b}}$. The vector $\boldsymbol{\varepsilon}$ is the *angular acceleration* of the moving frame, and \mathbf{w} is the *acceleration* of the origin of the non-inertial frame as a vector in this moving space. We use the identity

$$B^{-1}\ddot{B} = (B^{-1}\dot{B})\dot{B} - (B^{-1})\ddot{B}.$$

Since $B^{-1} = B^T$ and $(B^{-1}\dot{B})^T = -B^{-1}\dot{B}$, we have

$$-(B^{-1})\ddot{B} = -(\dot{B})^T B B^{-1}\dot{B} = B^{-1}\dot{B}B^{-1}\dot{B}.$$

Consequently,

$$B^{-1}\ddot{B} = (B^{-1}\dot{B})\dot{B} + B^{-1}\dot{B}B^{-1}\dot{B}.$$

Clearly,

$$(B^{-1}\dot{B})\mathbf{z} = \boldsymbol{\varepsilon} \times \mathbf{z} \quad \text{and} \quad B^{-1}\dot{B}B^{-1}\dot{B}\mathbf{z} = \boldsymbol{\omega} \times (\boldsymbol{\omega} \times \mathbf{z}).$$

As a result we obtain the required formula for $\boldsymbol{\Phi}$:

$$\boldsymbol{\Phi}_i = -m[\mathbf{w} + \boldsymbol{\omega} \times (\boldsymbol{\omega} \times \mathbf{z}_i) + \boldsymbol{\varepsilon} \times \mathbf{z}_i].$$

The expression in brackets is the acceleration of the point of the moving frame with position vector \mathbf{z}_i (the *transfer acceleration*). The force $\boldsymbol{\Psi}$ is called the *inertial force of the moving space*.

Now suppose that in some (generally speaking, non-inertial) frame we are given a law of motion of a closed system of n material points:

$$m_i\ddot{\mathbf{z}}_i = \mathbf{G}_i(\mathbf{z}_1, \dots, \mathbf{z}_n, \dot{\mathbf{z}}_1, \dots, \dot{\mathbf{z}}_n, t), \quad i = 1, \dots, n. \quad (1.16)$$

Then the vector-functions \mathbf{G}_i must be representable in the form of the right-hand sides of system (1.13):

$$\begin{aligned} \mathbf{G}_i(\mathbf{z}_j, \dot{\mathbf{z}}_k, t) = & \mathbf{F}_i(\mathbf{z}_k - \mathbf{z}_j, B^{-1}\dot{B}(\mathbf{z}_k - \mathbf{z}_j) + \dot{\mathbf{z}}_k - \dot{\mathbf{z}}_j) \\ & - m_i B^{-1}\ddot{B}\mathbf{z}_i - 2m_i B^{-1}\dot{B}\dot{\mathbf{z}}_i - m_i B^{-1}\ddot{\mathbf{b}}. \end{aligned} \quad (1.17)$$

It turns out that each summand on the right-hand side can be uniquely expressed in terms of \mathbf{G}_i .

Indeed, by (1.17) we have

$$\mathbf{G}_i(\mathbf{z}_j, \dot{\mathbf{z}}_k, t) - \mathbf{G}_i(\mathbf{z}_j + \mathbf{a}, \dot{\mathbf{z}}_k, t) = m_i B^{-1} \ddot{\mathbf{B}} \mathbf{a} \quad (1.18)$$

for any vector \mathbf{a} , and

$$\mathbf{G}_i(\mathbf{z}_j, \dot{\mathbf{z}}_k, t) - \mathbf{G}_i(\mathbf{z}_j, \dot{\mathbf{z}}_k + \mathbf{v}t) = 2m_i B^{-1} \dot{\mathbf{B}} \mathbf{v} \quad (1.19)$$

for any vector \mathbf{v} . Since $\mathbf{z} \mapsto -\mathbf{z}$ is an orthogonal transformation, by (1.9) we have

$$\mathbf{F}_i(-\mathbf{z}_j, -\dot{\mathbf{z}}_k) = -\mathbf{F}_i(\mathbf{z}_j, \dot{\mathbf{z}}_k).$$

Hence,

$$\mathbf{G}_i(\mathbf{z}_j, \dot{\mathbf{z}}_k, t) + \mathbf{G}_i(-\mathbf{z}_j, -\dot{\mathbf{z}}_k, t) = -2m_i B^{-1} \ddot{\mathbf{b}}. \quad (1.20)$$

Relations (1.18)–(1.20) allow one to determine $B^{-1} \dot{\mathbf{B}}$, $B^{-1} \ddot{\mathbf{B}}$, and $B^{-1} \ddot{\mathbf{b}}$ or, which is the same, the vectors $\boldsymbol{\omega}$, $\boldsymbol{\varepsilon}$, and \mathbf{w} . In particular, the forces \mathbf{G}_i in (1.16) acting on the material points in the non-inertial frame can be *uniquely* represented as the sum of the “physical” forces \mathbf{F}_i and the forces of inertia $\boldsymbol{\Phi}_i$ and $\boldsymbol{\Psi}_i$.

Thus, if we know the law of motion (1.16) of a system of points in the non-inertial frame, then we can uniquely determine the vectors $\boldsymbol{\omega}$ and $\mathbf{w} = B^{-1} \ddot{\mathbf{b}}$. Consequently, the orthogonal matrix $B(t)$ satisfies the equation

$$\dot{B} = B\Omega, \quad (1.21)$$

where $\Omega(t)$ is the known skew-symmetric matrix (1.15). For any orthogonal matrix B_0 there exists a unique solution $B(t)$ of equation (1.21) such that $B(0) = B_0$. Since we know the acceleration vector \mathbf{w} , we can find the vector $\ddot{\mathbf{b}}(t) = B(t)\mathbf{w}(t)$, the acceleration of the origin of the moving frame in the fixed space. Consequently, the position vector of this point can be found by simple quadratures:

$$\mathbf{b}(t) = \int_0^t \left(\int_0^\eta \ddot{\mathbf{b}}(\xi) d\xi \right) d\eta + \mathbf{v}t + \mathbf{a},$$

where \mathbf{v} and \mathbf{a} are some constant vectors. Fixing B_0 , \mathbf{v} , and \mathbf{a} we obtain formula (1.10) connecting some inertial frame and the chosen non-inertial frame. Since the time is not transformed in the transition formula (1.10), by varying the orthogonal matrix B_0 and the vectors \mathbf{v} , \mathbf{a} we can obtain the whole family of inertial frames.

These observations lead to an important consequence of the relativity principle: the law of motion of any closed system of interacting points in some fixed moving frame allows one to find all the inertial frames [352].

We emphasize that without the assumption of the validity of the relativity principle it is impossible to unambiguously distinguish the physical forces of interaction from the forces of inertia. This range of problems is discussed from a somewhat different viewpoint in [294].

1.1.5 Basic Dynamical Quantities. Conservation Laws

The following characteristics of motion are important in dynamics in oriented Euclidean space with a fixed inertial frame:

- $\mathbf{p} = m\mathbf{v}$ — the *momentum* of a point,
- $\mathbf{k} = \mathbf{r} \times \mathbf{p} = m(\mathbf{r} \times \mathbf{v})$ — the *angular momentum* (*moment of momentum*),
- $\mathbf{M} = \mathbf{r} \times \mathbf{F}$ — the *moment of force* (*torque*),
- $T = mv^2/2$ — the *kinetic energy*,
- $I = mr^2$ — the *moment of inertia with respect to the point o*.

If a system consists of several points, then the corresponding dynamical quantities are additive functions.

Proposition 1.2. *Let $\mathbf{P} = \sum \mathbf{p}_i$ and $\mathbf{F} = \sum \mathbf{F}_i$. Then $\dot{\mathbf{P}} = \mathbf{F}$.*

The point

$$\boldsymbol{\xi} = \frac{\sum m_i \mathbf{r}_i}{\sum m_i}$$

is called the *centre of mass*. It is easy to see that the position of the centre of mass is independent of the choice of the origin of reference.

Corollary 1.1. *The centre of mass of a closed system moves uniformly and rectilinearly: $\ddot{\boldsymbol{\xi}} = 0$.*⁴

Proposition 1.3. *Let $\mathbf{K} = \sum \mathbf{k}_i = \sum m_i \mathbf{r}_i \times \mathbf{v}_i$ and $\mathbf{M} = \sum \mathbf{r}_i \times \mathbf{F}_i$. Then $\dot{\mathbf{K}} = \mathbf{M}$.*

Corollary 1.2. *For a closed system we have $\mathbf{K} = \text{const}$.*⁵

A force acting on a material point is said to be *central* if its line of action always passes through the origin $o \in E^3$.

Corollary 1.3. *A motion under the action of a central force occurs in a plane passing through o.*

Proposition 1.4. *Let $T = \sum m_i v_i^2/2$. Then $\dot{T} = \sum \langle \mathbf{F}_i, \mathbf{v}_i \rangle$.*

The forces $\mathbf{F}_i(\mathbf{r}_1, \dots, \mathbf{r}_n)$ are said to be *conservative* if the 1-form

$$\sum_{i=1}^n \langle \mathbf{F}_i(\mathbf{r}), d\mathbf{r}_i \rangle,$$

called the *work of the forces \mathbf{F}_i* on the displacements $d\mathbf{r}_i$, is exact, that is, is the differential of some function $V(\mathbf{r}_1, \dots, \mathbf{r}_n)$ defined everywhere on

$$E^{3n} \setminus \Delta = E^{3n} \setminus \bigcup_{i < j} \{\mathbf{r}_i = \mathbf{r}_j\}.$$

⁴ This assertion was noted by Newton.

⁵ This fact was established independently by Euler, D. Bernoulli, and d’Arcy (see [477]).

The function V is called the *force function*⁶, and the function $U = -V$ is called the *potential energy (potential)* of the system of points.

Corollary 1.4. *If the forces are conservative, then the total energy is constant on every motion: $T + U = \text{const.}$* ⁷

The existence of the laws of conservation of momentum, angular momentum, and total energy of a closed system of material points is related to the invariance of Newton's equations under the Galilean transformation group.

Proposition 1.5. *If the interaction forces depend only on the mutual distances of the points, that is,*

$$\mathbf{F}_{ij} = \mathbf{f}_{ij}(r_{ij})\mathbf{e}_{ij}, \quad r_{ij} = |\mathbf{r}_i - \mathbf{r}_j|, \quad \mathbf{e}_{ij} = \frac{\mathbf{r}_j - \mathbf{r}_i}{r_{ij}},$$

then these forces are conservative.⁸

In this case the potential energy is equal to $\sum_{i < j} u_{ij}$, where $u_{ij} = \int \mathbf{f}_{ij}(r_{ij}) dr_{ij}$ is the potential energy of interaction of the material points m_i and m_j .

For example, in the case of universal gravitation the force function is

$$V = \sum_{i < j} \frac{\gamma m_i m_j}{r_{ij}}.$$

Proposition 1.6. *Let $I = \sum m_i r_i^2$ be the moment of inertia of the system with respect to the origin $o \in E^3$. Then $\ddot{I} = 4T + 2 \sum_i \langle \mathbf{F}_i, \mathbf{r}_i \rangle$.*

If the forces are conservative and the force function is homogeneous of degree k , then

$$\ddot{I} = 4T + 2 \sum_i \left\langle \frac{\partial V}{\partial \mathbf{r}_i}, \mathbf{r}_i \right\rangle = 4T + 2kV = 4h + 2(k+2)V$$

depends only on the positions of the points and the total energy. In the case of gravitational attraction, $k = -1$ and therefore $\ddot{I} = 4h - 2U$. This formula was obtained by Lagrange.

As an application of the dynamical quantities and conservation laws introduced above we now consider the problem of *regions of possible motion* of a closed system whose interaction forces depend only on the distance.

We associate with the centre of mass (*barycentre*) a new inertial frame and in what follows consider the barycentre to be at rest: $\sum m_i \mathbf{r}_i = 0$. Clearly,

⁶ The force function was introduced by Lagrange.

⁷ In special cases this fact was already known to Huygens, Newton, J. and D. Bernoulli, and other authors.

⁸ This fact was established by Lagrange.

the interaction forces \mathbf{F}_{ij} do not change under such a change of the origin of reference, since they depend only on the differences $\mathbf{r}_i - \mathbf{r}_j$.

The total angular momentum $\mathbf{K} = \sum m_i(\mathbf{r}_i \times \mathbf{v}_i)$ with respect to the centre of mass does not change. The plane passing through the barycentre perpendicular to the constant vector \mathbf{K} is usually called the Laplacian invariant plane.

Proposition 1.7. *We have the inequality*

$$K^2 \leq 2IT. \quad (1.22)$$

◁ Indeed,

$$\begin{aligned} K^2 &= \left| \sum m_i(\mathbf{r}_i \times \mathbf{v}_i) \right|^2 \leq \left(\sum m_i |\mathbf{r}_i| |\mathbf{v}_i| \right)^2 \\ &\leq \left(\sum m_i \mathbf{r}_i^2 \right) \left(\sum m_i \mathbf{v}_i^2 \right) = I \cdot 2T. \end{aligned} \quad \triangleright$$

Since $T = h - U$, we obtain from (1.22) the inequality $K^2 \leq 2I(h - U)$ or $U + K^2/(2I) \leq h$. We consider the hypersurface

$$\Gamma = \left\{ \mathbf{r} = (\mathbf{r}_1, \dots, \mathbf{r}_n) \in \mathbb{R}^{3n} : \sum m_i \mathbf{r}_i = 0 \right\}$$

and denote by $B_{K,h}$ the region of possible motion – the set of points of Γ where the system can be situated with a given energy and given value of the total angular momentum. We obviously have the inclusions

$$B_{K,h} \subset \{ \mathbf{r} \in \Gamma : U + K^2/(2I) \leq h \} \subset \Gamma.$$

The reverse inclusion, generally speaking, does not hold.

Proposition 1.8. *In the planar problem, when the motion of points takes place in the Laplacian plane, we have $B_{K,h} = \{ \mathbf{r} \in \Gamma : U + K^2/(2I) \leq h \}$.*

◁ Suppose that $\sum m_i \mathbf{r}_i = 0$ and let $\mathbf{v}_i = (\mathbf{K} \times \mathbf{r}_i)/I + \alpha \mathbf{r}_i/I$. Then $\sum m_i(\mathbf{r}_i \times \mathbf{v}_i) = \mathbf{K}$ and $T = K^2/2I + \alpha^2/2I$. It is always possible to choose α so that $\mathbf{r} \in B_{K,h}$. ◻

1.2 Lagrangian Mechanics

1.2.1 Preliminary Remarks

We begin with a simple example. Suppose that a point of mass m moves on a smooth⁹ regular surface Σ given by an equation

$$f(x, y, z) = 0 \quad (1.23)$$

⁹ Here smoothness should be interpreted in two meanings: as infinite differentiability and as absence of friction.

under the action of a known force \mathbf{F} . The effect of the surface Σ on the motion of the point can be naturally identified with the action of some force \mathbf{N} orthogonal to Σ . We can describe the motion of the point m by Newton's equation

$$m\ddot{\mathbf{r}} = \mathbf{F} + \mathbf{N} \quad (1.24)$$

and then regard the point as being free. From this equation, taking into account the *constraint equation* (1.23), we can uniquely determine the force \mathbf{N} as a function of state and time. Equation (1.24) can be rewritten in the form

$$\langle m\ddot{\mathbf{r}} - \mathbf{F}, \boldsymbol{\xi} \rangle = 0, \quad (1.25)$$

where $\boldsymbol{\xi}$ is an arbitrary tangent vector to Σ , and interpreted as Newton's law of motion in the tangent plane to the surface Σ .

In mechanics the force \mathbf{N} is usually called the pressure or, more generally, the *reaction of the constraint* (1.23), and the tangent vectors $\boldsymbol{\xi}$, the *virtual variations (displacements)* or *virtual velocities* of the constrained point m .

In the general case, when n points $(m_1, \mathbf{r}_1), \dots, (m_n, \mathbf{r}_n)$ are in constrained motion, the constraints are defined by a smooth manifold M embedded in the configuration space of the free system $\mathbb{R}^{3n} = \mathbb{R}^3\{\mathbf{r}_1\} \times \dots \times \mathbb{R}^3\{\mathbf{r}_n\}$. The constraints allow only the motions such that $(\mathbf{r}_1(t), \dots, \mathbf{r}_n(t)) \in M$ for all t . If known forces $\mathbf{F}_1, \dots, \mathbf{F}_n$ act on the points, then equation (1.25) can be naturally generalized to

$$\sum_{i=1}^n \langle m_i \ddot{\mathbf{r}}_i - \mathbf{F}_i, \boldsymbol{\xi}_i \rangle = 0, \quad (1.26)$$

where $(\boldsymbol{\xi}_1, \dots, \boldsymbol{\xi}_n)$ is an arbitrary tangent vector to M . This equation is called the "general equation of dynamics" or the *d'Alembert–Lagrange principle*. In the case of a free system of points the vectors $\boldsymbol{\xi}_i$ are arbitrary and therefore equation (1.26) is equivalent to Newton's system of equations. The d'Alembert–Lagrange principle is the definition of motion of a system with constraints. We shall show in § 1.6 that this definition is natural.

Let $q = (q_1, \dots, q_k)$ be local coordinates on M . Then the \mathbf{r}_i are smooth functions of q and

$$\dot{\mathbf{r}}_i = \sum_{j=1}^k \frac{\partial \mathbf{r}_i}{\partial q_j} \dot{q}_j.$$

The kinetic energy

$$T(\dot{q}, q) = \frac{1}{2} \sum m_i \dot{\mathbf{r}}_i^2$$

is a positive definite quadratic form on M . We also introduce the "*generalized forces*" – the covectors $Q(q)$ defined by the equality

$$\sum_{i=1}^n \langle \mathbf{F}_i, d\mathbf{r}_i \rangle = \sum_{j=1}^k Q_j dq_j.$$

Theorem 1.1 (Lagrange). *The functions $q(t)$ defining the motion of the constrained system satisfy the equation*

$$(T'_q)' - T'_q = Q.$$

If the forces $\mathbf{F}_1, \dots, \mathbf{F}_n$ are conservative (in the sense of the definition in §1.1), then the form $\sum Q_j(q) dq_j$ is the total differential of some smooth function $V(q)$. Then it is natural to introduce the function $L = T + V$ and rewrite the equation of motion in the form of *Lagrange's equation*

$$(L'_q)' = L'_q.$$

This immediately implies that the motions of the mechanical system coincide with the extremals of the variational problem

$$\delta \int_{t_1}^{t_2} L dt = 0.$$

“Oddly enough, in Lagrange’s work this principle is stated only between the lines; this could be whence the strange fact developed that this relation in Germany – mainly through the works of Jacobi – and thereby also in France is universally called *Hamilton’s principle*, whereas in England nobody understands this expression; there this equality is called rather by a correct but undescriptive name of the *principle of stationary action*” (F. Klein, *Vorlesungen über die Entwicklung der Mathematik im 19. Jahrhundert*. I. Springer, Berlin, 1926).

1.2.2 Variations and Extremals

A *Lagrangian system* on a smooth manifold M is defined by a single function $L: TM \times \Delta \rightarrow \mathbb{R}$, where Δ is an interval of the time axis $\mathbb{R} = \{t\}$. A point $q \in M$ is called a configuration (or position) of the system, and a tangent vector $v \in T_qM$, a velocity at configuration q . The pair q, v is also called a state of the system. In Lagrangian mechanics the manifold M is normally called the configuration space; the tangent bundle TM , the state space; L the *Lagrange function* or the *Lagrangian*; and $\dim M$, the *number of degrees of freedom*.

Example 1.1. A natural mechanical system is a triplet (M, T, V) , where M is a smooth configuration manifold, T is a Riemannian metric on M (the kinetic energy of the system), V is a smooth function on M (the potential of the force field). A Riemannian metric is a smooth function on the tangent bundle that is a positive definite quadratic form on each tangent plane. The Lagrange function is $L = T + V$ (the function $V: M \rightarrow \mathbb{R}$ is lifted to a function from TM into \mathbb{R} in the obvious way). \triangle

Let a_1 and a_2 be two (not necessarily distinct) points in M . A path from a_1 to a_2 starting at time t_1 and finishing at time t_2 ($t_1, t_2 \in \Delta$) is by definition a map of class C^∞

$$\omega: [t_1, t_2] \rightarrow M$$

such that $\omega(t_1) = a_1$ and $\omega(t_2) = a_2$. The set of all such paths is denoted by $\Omega(M; a_1, a_2; t_1, t_2)$, or simply Ω if this causes no confusion.

One can think of Ω as some “infinite-dimensional manifold”. A *vector field* W along a path ω is a function associating with each $t \in [t_1, t_2]$ a tangent vector

$$W_t \in TM_{\omega(t)}.$$

This function must be smooth in the following sense: for every smooth function $q \mapsto f(q)$ on M the correspondence

$$t \mapsto \frac{\partial f}{\partial q} W_t$$

must define a smooth function. We define the tangent space to Ω at the point ω as the vector space consisting of the smooth vector fields W along the path ω such that $W_{t_1} = 0$ and $W_{t_2} = 0$. We denote the tangent space to Ω at the point ω by $T_\omega \Omega$.

A *variation of the path* ω (with fixed ends) is a map $\hat{\alpha}: (-\varepsilon, \varepsilon) \rightarrow \Omega$ such that

- 1) $\hat{\alpha}(0) = \omega$;
- 2) the map $\alpha: (-\varepsilon, \varepsilon) \times [t_1, t_2] \rightarrow M$ defined by the formula $\alpha(u, t) = \hat{\alpha}(u)(t)$ is a smooth function of the variables u, t .
Since $\hat{\alpha} \in \Omega(M; a_1, a_2; t_1, t_2)$, we have
- 3) $\alpha(u, t_1) = a_1$ and $\alpha(u, t_2) = a_2$ for all $u \in (-\varepsilon, \varepsilon)$.

By a variation of the path ω we shall also mean the map α .

The variation $\hat{\alpha}$ can be regarded as a “smooth” path on Ω . One can naturally define its velocity vector

$$\frac{d\hat{\alpha}}{du}(0) \in T_\omega \Omega$$

as the vector field $W_t \in T_{\omega(t)}M$ along ω given by

$$W_t = \frac{\partial \alpha}{\partial u}(0, t).$$

Since

$$\frac{\partial \alpha}{\partial u}(0, t) \in T_{\omega(t)}M$$

for all $t_1 \leq t \leq t_2$ and

$$\frac{\partial \alpha}{\partial u}(0, t_1) = 0, \quad \frac{\partial \alpha}{\partial u}(0, t_2) = 0,$$

we indeed have $W_t \in T_\omega \Omega$.

Lemma 1.1. For any $W \in T_\omega\Omega$ there exists a variation $\widehat{\alpha}(u)$ such that

$$\frac{d\widehat{\alpha}}{du}(0) = W.$$

The vector field W_t is called a *variation vector field*. Of course, it does not uniquely determine the variation of motion.

Example 1.2. Let q_1, \dots, q_n be local coordinates on M and let W_1, \dots, W_n be the components of a tangent field W with respect to the basis $\frac{\partial}{\partial q_1}, \dots, \frac{\partial}{\partial q_n}$. If a path $\omega(t)$ is represented by smooth functions $q_1^*(t), \dots, q_n^*(t)$, then one can define a variation $\alpha(u, t)$ by the formulae

$$q_1(u, t) = q_1^*(t) + uW_1(t), \dots, q_n(u, t) = q_n^*(t) + uW_n(t). \quad \triangle$$

Let $F: \Omega \rightarrow \mathbb{R}$ be a numerical function (a functional, in the classical terminology) on Ω . We shall now define the differential $\delta F: T_\omega\Omega \rightarrow \mathbb{R}$, which is called the *variation of the functional* F .

Let $W \in T_\omega\Omega$. By Lemma 1.1 there exists a variation $\widehat{\alpha}(u): (-\varepsilon, \varepsilon) \rightarrow \Omega$ such that

$$\widehat{\alpha}(0) = \omega, \quad \frac{d\widehat{\alpha}}{du}(0) = W.$$

We set by definition

$$\delta F(W) = \frac{dF(\widehat{\alpha}(u))}{du}(0).$$

We should verify that the definition of the variation is correct: that $\delta F(W)$ is a linear function of W independent of the choice of the variation of the path $\alpha(u)$. However, we shall not go into this, since these conditions are certainly satisfied in the cases considered below.

A point $\omega \in \Omega$ is critical (stationary) for F if $\delta F \equiv 0$ at this point. For example, suppose that F takes minimum value on a path ω_0 and the derivative

$$\frac{dF(\widehat{\alpha}(u))}{du}$$

exists. Then, obviously, the path ω_0 is critical.

1.2.3 Lagrange's Equations

Let $q: [t_1, t_2] \rightarrow M$ be a smooth path in the set Ω . The velocity v at time t is equal to the derivative $\dot{q}(t)$. At each moment of time $t_1 \leq t \leq t_2$ the sets of numbers $L'_{\dot{q}_i}$ and $(L'_{\dot{q}_i}) - L_{q_i}$ ($1 \leq i \leq n$) are defined, which are called the momentum of the system and the *Lagrangian derivative* of the function L and denoted by p and $[L]$, respectively.

We pass to new local coordinates \bar{q} by the formula $q = q(\bar{q})$. Let $J = \partial q / \partial \bar{q}$ be the non-singular Jacobi matrix of this change of variables. In the new coordinates the Lagrange function is given by the formula $\bar{L}(\dot{\bar{q}}, \bar{q}, t) = L(\dot{q}, q, t)$.

Lemma 1.2. We have $p = (J^\top)^{-1}\bar{p}$ and $[L] = (J^\top)^{-1}[\bar{L}]$.

These formulae can be proved by straightforward calculation.

Since p and $[L]$ are transformed according to the covariant law under changes of local coordinates, we can assume p and $[L]$ to be covectors defined at the point $q(t) \in M$. Consequently, the expressions $p \cdot w$ and $[L] \cdot w$ are well defined for tangent vectors $w \in T_{q(t)}M$.

Definition 1.1. The *action* is defined as the functional

$$F(\omega) = \int_{\omega} L dt = \int_{t_1}^{t_2} L(\dot{\omega}(t), \omega(t), t) dt.$$

Theorem 1.2 (first variation formula).

$$\delta F(W) = - \int_{t_1}^{t_2} ([L] \cdot W) dt. \quad (1.27)$$

◁ Let $\hat{\alpha}(u)$ be a variation of the path ω . Then

$$\frac{dF(\hat{\alpha}(u))}{du} = \int_{t_1}^{t_2} (L'_q q''_{ut} + L'_q q'_{ut}) dt.$$

Integrating by parts the first summand of the integrand we obtain

$$\frac{dF}{du}(0) = p \cdot W|_{t_1}^{t_2} - \int_{t_1}^{t_2} ([L] \cdot W) dt.$$

It remains to take into account that $W_{t_1} = 0$ and $W_{t_2} = 0$. ▷

Definition 1.2 (Hamilton's principle). A path $\omega \in \Omega$ is called a *motion* of the Lagrangian system (M, L) if ω is a critical point of the action functional.

It follows from (1.27) that the critical paths of the functional F coincide with the solutions of Lagrange's equation $[L]_{\omega(t)} = 0$. In particular, the restriction of a motion $\omega(t)$ to any subinterval of $[t_1, t_2]$ is again a motion.

In the local coordinates q on M Lagrange's equation can be written in the explicit form

$$A(\dot{q}, q, t)\ddot{q} + \Phi(\dot{q}, q, t) = 0,$$

where $A = L''_{\dot{q}\dot{q}}$.

Lemma 1.3. Let $\bar{A} = \bar{L}''_{\dot{q}\dot{q}}$. Then $A = (J^\top)^{-1}\bar{A}J^{-1}$.

If $\det A \neq 0$, then Lagrange's equation can be resolved with respect to the accelerations. This implies, in particular, that the state of the system at a moment of time $t_0 \in \Delta$ uniquely determines its motion. We emphasize that by Lemma 1.3 the condition that the matrix A be non-singular is independent of the choice of local coordinates on M .

1.2.4 Poincaré's Equations

Let v_1, v_2, \dots, v_n be tangent vector fields on an n -dimensional manifold M that are linearly independent at each point. At each point $q \in M$ the commutators $[v_i, v_j]$ can be written as linear combinations of the vectors v_1, \dots, v_n as a basis: $[v_i, v_j] = \sum c_{ij}^k(q)v_k$. If $q: \Delta \rightarrow M$ is some smooth path and f is a smooth function on M , then

$$\dot{f} = f'_q \cdot \dot{q} = \sum_{i=1}^n v_i(f)\omega_i, \tag{1.28}$$

where $v_i(f)$ is the derivative of f in the direction v_i . The variables ω are linear functions of the velocities. They are called “quasi-velocities”. We represent the Lagrangian as a function of q and ω : $\widehat{L}(\omega, q) = L(\dot{q}, q)$. Let $q(u, t)$ be a variation of the path $q(t)$. We set

$$\frac{\partial f(q(u, t))}{\partial u} = \sum_j v_j(f)w_j.$$

Since the differentiations with respect to q and t commute, we obtain the equalities

$$\frac{\partial \omega_k}{\partial u} = \frac{\partial w_k}{\partial t} + \sum_{i,j} c_{ij}^k \omega_i w_j.$$

We calculate the variation of the action in terms of the quasi-velocities:

$$\begin{aligned} \delta \int_{t_1}^{t_2} \widehat{L}(\omega, q) dt \\ = \sum_k \frac{\partial \widehat{L}}{\partial \omega_k} \cdot w_k \Big|_{t_1}^{t_2} + \int_{t_1}^{t_2} \sum_k \left[-\frac{d}{dt} \frac{\partial \widehat{L}}{\partial \omega_k} + \sum_{i,j} c_{ik}^j \frac{\partial \widehat{L}}{\partial \omega_j} \omega_i + v_k(\widehat{L}) \right] \cdot w_k dt. \end{aligned}$$

Since the variations w_k are independent inside the interval (t_1, t_2) and vanish at its ends, Hamilton's principle gives us the equations of motion in the coordinates q, ω :

$$(\widehat{L}'_{\omega_k})' = \sum_{i,j} c_{ik}^j \widehat{L}'_{\omega_j} \omega_i + v_k(\widehat{L}).$$

These equations were for the first time obtained by Poincaré in 1901. If the independent vectors $\partial/\partial q_k$ are taken for the v_k , then Poincaré's equations turn into ordinary Lagrange's equations.

Now suppose that M is a Lie group G and v_1, \dots, v_n are independent left-invariant fields on G . Then $c_{ij}^k = \text{const}$. Suppose that the Lagrangian is invariant under left translations on G . Then $v_k(\widehat{L}) \equiv 0$, and therefore \widehat{L} depends only on the quasi-velocities ω , which should be regarded as coordinates in the Lie algebra \mathfrak{g} of the group G . Under these assumptions Poincaré's equations form a closed system of differential equations on \mathfrak{g} .

Example 1.3. A *rigid body* with a fixed point is by definition a set of material points subjected to the following constraints (in the sense of § 1.2.1):

- a) the distances between the points are constant,
- b) one of the points of the body coincides with some fixed point o in E^3 .

Clearly, every position of the rigid body can be uniquely obtained from some fixed position by a rotation of E^3 around the point o . Therefore the configuration space of this system can be identified with the group $SO(3)$. A rotational motion of the rigid body is defined by a function $B(t)$, where B is an orthogonal matrix in $SO(3)$. The velocity of rotation $\dot{B}(t)$ is a tangent vector to the group at the point $B(t)$. It is natural to transfer this vector into the tangent space of the group at the identity element, that is, into the Lie algebra $so(3)$. This can be done in two ways: by a left or right translation. As a result we obtain two skew-symmetric matrices $B^{-1}\dot{B}$ and $\dot{B}B^{-1}$ in the algebra $so(3)$.

Let $\mathbf{R}(t)$ be the position vector of a point of the body in the fixed space. Then $\mathbf{R}(t) = B(t)\mathbf{R}(0)$ and therefore

$$\mathbf{V}(t) = \dot{\mathbf{R}}(t) = \dot{B}(t)\mathbf{R}(0) = \dot{B}(t)B^{-1}(t)\mathbf{R}(t).$$

In three-dimensional oriented Euclidean space every skew-symmetric operator is the operator of vector (cross) multiplication $\boldsymbol{\Omega} \times (\cdot)$ by some vector $\boldsymbol{\Omega}$. As a result we obtain Euler's formula $\mathbf{V} = \boldsymbol{\Omega} \times \mathbf{R}$. The vector $\boldsymbol{\Omega}$ is called the *angular velocity* in space (cf. § 1.1.4).

If \mathbf{r} is the position vector and \mathbf{v} the velocity of the same point in the moving space attached to the rigid body, then again $\mathbf{v} = \boldsymbol{\omega} \times \mathbf{r}$, where $\boldsymbol{\omega} = B^{-1}\boldsymbol{\Omega}$ is the angular velocity vector in the body. The correspondence $f: B^{-1}\dot{B} \rightarrow \boldsymbol{\omega}$ defines an isomorphism of the algebra $so(3)$ (which can be interpreted as the algebra of left-invariant fields on $SO(3)$) and the algebra of vectors of three-dimensional oriented Euclidean space, where the commutator is the ordinary vector cross product.

Let m be the mass distribution in the rigid body. We define the angular momentum of the body (in the moving space) as the vector

$$\mathbf{k} = \int (\mathbf{r} \times \mathbf{v}) dm = \int (\mathbf{r} \times (\boldsymbol{\omega} \times \mathbf{r})) dm.$$

The symmetric linear operator $A: \boldsymbol{\omega} \rightarrow \mathbf{k}$ is called the *inertia operator*, and its mutually perpendicular characteristic directions l_i are called the *principal inertia axes*. The eigenvalues of the operator A can be calculated by the formula

$$A_i = \int r_i^2 dm,$$

where r_i is the distance from the point of the rigid body to the axis l_i . The numbers A_i are called the *moments of inertia* of the body with respect to the axes l_i .

Problem. Find a straight line passing through the centre of a cube such that the sum of squares of the distances from the vertices to this line is a minimum.

Solution. The quadratic form corresponding to the operator A (for the body consisting of the 8 vertices of the cube carrying equal masses) is invariant under the cube's symmetries. Hence the level surfaces of this form (called the inertia ellipsoids of the body) are also invariant under the cube's symmetries, including the symmetries of order three defined by rotations around a diagonal.

But an ellipsoid can have symmetries of order three only if it is an ellipsoid of revolution around an axis of symmetry. Consequently, the inertia ellipsoid of the cube has at least 4 axes of rotation (a cube has 4 diagonals) and therefore is a sphere.

Thus, the sum of the squares of the distances from the vertices of the cube to the straight line (that is, the moment of inertia with respect to this line) is independent of the direction of the line (and is always a minimum, whichever line is chosen). \triangle

The kinetic energy of the rigid body

$$T = \frac{1}{2} \int V^2 dm = \frac{1}{2} \int v^2 dm$$

is, in view of the formula $T = \langle \mathbf{k}, \boldsymbol{\omega} \rangle / 2 = \langle A\boldsymbol{\omega}, \boldsymbol{\omega} \rangle / 2$, a quadratic form in the angular velocity.

Let \mathbf{e}_i be the unit vectors of the principal axes numbered so that

$$\mathbf{e}_1 \times \mathbf{e}_2 = \mathbf{e}_3, \quad \mathbf{e}_2 \times \mathbf{e}_3 = \mathbf{e}_1, \quad \mathbf{e}_3 \times \mathbf{e}_1 = \mathbf{e}_2.$$

Let v_1, v_2, v_3 be the left-invariant vector fields on $SO(3)$ that are the inverse images of the vectors $\mathbf{e}_1, \mathbf{e}_2, \mathbf{e}_3$ under the isomorphism $f: so(3) \rightarrow \mathbb{R}^3\{\boldsymbol{\omega}\}$. Clearly,

$$[v_1, v_2] = v_3, \quad [v_2, v_3] = v_1, \quad [v_3, v_1] = v_2. \tag{1.29}$$

Let $\boldsymbol{\omega} = \sum \omega_i \mathbf{e}_i$. Then

$$T = \frac{A_1 \omega_1^2 + A_2 \omega_2^2 + A_3 \omega_3^2}{2}. \tag{1.30}$$

Using (1.29) and (1.30) we write down in explicit form Poincaré's equations in the absence of external forces:

$$\begin{aligned} A_1 \dot{\omega}_1 &= (A_2 - A_3) \omega_2 \omega_3, \\ A_2 \dot{\omega}_2 &= (A_3 - A_1) \omega_3 \omega_1, \\ A_3 \dot{\omega}_3 &= (A_1 - A_2) \omega_1 \omega_2. \end{aligned}$$

These equations, which were for the first time obtained by Euler in 1758, can be replaced by the single vector equation $A\dot{\boldsymbol{\omega}} + \boldsymbol{\omega} \times A\boldsymbol{\omega} = 0$.

We now consider a more general case where a rigid body is placed in an axially symmetric force field with force function V . In view of Poincaré's equations one must add the summands $v_i(V)$ on the right-hand side of Euler's equations. Let $\boldsymbol{\gamma} = \sum \gamma_i \mathbf{e}_i$ be a unit vector of the symmetry axis of the field. Clearly, $V = V(\gamma_1, \gamma_2, \gamma_3)$. The condition that the vector $\boldsymbol{\gamma}$ be constant in the fixed space is equivalent to the equation

$$\dot{\boldsymbol{\gamma}} = \boldsymbol{\gamma} \times \boldsymbol{\omega}, \quad (1.31)$$

which is called Poisson's equation. Using the formula

$$\dot{V} = \left\langle \frac{\partial V}{\partial \boldsymbol{\gamma}}, \dot{\boldsymbol{\gamma}} \right\rangle = \left\langle \frac{\partial V}{\partial \boldsymbol{\gamma}}, \boldsymbol{\gamma} \times \boldsymbol{\omega} \right\rangle = \left\langle \boldsymbol{\omega}, \frac{\partial V}{\partial \boldsymbol{\gamma}} \times \boldsymbol{\gamma} \right\rangle$$

and (1.28) we obtain the equation of motion of the rigid body

$$A\dot{\boldsymbol{\omega}} + \boldsymbol{\omega} \times A\boldsymbol{\omega} = \boldsymbol{\gamma} \times \frac{\partial V}{\partial \boldsymbol{\gamma}}. \quad (1.32)$$

The closed system of equations (1.31)–(1.32) is called the *Euler–Poisson equations*.

Example 1.4. We consider in addition the problem of the motion of a rigid body in boundless ideal fluid. The configuration space of the rigid body is the group of motions $L(3)$ of three-dimensional Euclidean space. Its Lie algebra $l(3)$ is the semidirect sum of the rotation algebra $so(3)$ and the three-dimensional commutative algebra of translations. Rotation of the rigid body is described by *Kirchhoff's equations* (1870)

$$\dot{\mathbf{k}} = \mathbf{k} \times \boldsymbol{\omega} + \mathbf{e} \times \mathbf{u}, \quad \dot{\mathbf{e}} = \mathbf{e} \times \boldsymbol{\omega},$$

where $\boldsymbol{\omega} = H'_{\mathbf{k}}$, $\mathbf{u} = H'_{\mathbf{e}}$, and $H(\mathbf{k}, \mathbf{e}) = (1/2)\langle A\mathbf{k}, \mathbf{k} \rangle + \langle B\mathbf{k}, \mathbf{e} \rangle + (1/2)\langle C\mathbf{e}, \mathbf{e} \rangle$ is the kinetic energy of the system “body + fluid”, where A, C are symmetric operators. The vectors $\boldsymbol{\omega}$ and \mathbf{k} are the angular velocity and the angular momentum, while \mathbf{e} and \mathbf{u} are the “momentum force” and “momentum moment” of the body in the fluid. \triangle

One can show that Kirchhoff's equations are Poincaré's equations on the algebra $l(3)$. A detailed discussion of Kirchhoff's problem can be found in the books [112, 366].

1.2.5 Motion with Constraints

We say that constraints are imposed on a Lagrangian system (M, L) if, at each moment of time $t \in \Delta$, a submanifold S is distinguished in the phase space TM defined locally by equations

$$f_1(q, \dot{q}, t) = \cdots = f_m(q, \dot{q}, t) = 0$$

with covectors $f'_{1\dot{q}}, \dots, f'_{m\dot{q}}$ linearly independent at each point. The constraints allow only those paths $\omega: \Delta \rightarrow M$ for which $(\dot{\omega}(t), \omega(t)) \in S$ for all $t \in \Delta$. Usually linear constraints are considered when the functions f_s are linear in the velocities. Under these conditions the triplet (M, L, S) is called a Lagrangian system with constraints.

The tangent vectors $\xi \in T_q M$ satisfying the equations

$$f'_{1\dot{q}} \cdot \xi = \dots = f'_{m\dot{q}} \cdot \xi = 0$$

are called *virtual velocities* of the system (M, L, S) at time t and state $(q, \dot{q}) \in S$. This definition is correct by Lemma 1.2.

Definition 1.3 (d'Alembert–Lagrange principle). An admissible smooth path $q: \Delta \rightarrow M$ is called a *motion of the Lagrangian system with constraints* (M, L, S) if at every moment of time $t \in \Delta$ we have $[L]_{q(t)} \cdot \xi = 0$ for all virtual velocities ξ at the state $(q(t), \dot{q}(t))$.

Using this principle we can write down the closed system of equations of motion

$$[L] = \sum_{j=1}^m \mu_j f'_{j\dot{q}}, \quad f_1 = \dots = f_m = 0, \tag{1.33}$$

which are called Lagrange's equations with multipliers. If the matrix

$$(f'_{i\dot{q}} (L''_{\dot{q}\dot{q}})^{-1} f'_{j\dot{q}}) \tag{1.34}$$

is non-singular, then the multipliers μ_j can be represented as functions of the state of the system and time. In this case equations (1.33) are differential equations on S (possibly, non-autonomous) and therefore Lagrangian systems with constraints obey the principle of determinacy.

The d'Alembert–Lagrange principle has several equivalent formulations. We give two of them which are due to Gauss and Hölder.

Following Gauss we introduce the set of *conceivable motions* – smooth paths $q_\mu: \Delta \rightarrow M$ allowed by the constraints and having at some fixed time $t_0 \in \Delta$ one and the same state $(a, v) \in S$. A path $q_0: \Delta \rightarrow M$ with the same state at time t_0 is called a *released motion* if $[L]_{q_0(t)} = 0$ for all $t \in \Delta$. Finally, an *actual motion* $q_d: \Delta \rightarrow M$ is a map satisfying the d'Alembert–Lagrange principle and the initial condition $q_d(t_0) = a, \dot{q}_d(t_0) = v$. We stress that, unlike conceivable or actual motions, released motions in general do not satisfy the constraint equations.

Let $A = L''_{\dot{q}\dot{q}}$, and let $q_\alpha(t), q_\beta(t)$ be arbitrary smooth paths with the same state (a, v) at time t_0 . The quadratic form

$$Z = \frac{1}{2} (A(\ddot{q}_\alpha - \ddot{q}_\beta) \cdot (\ddot{q}_\alpha - \ddot{q}_\beta)) \Big|_{t_0}$$

is called the *compulsion* (or *constraint*) according to Gauss. It is easy to verify that under changes of local coordinates on M the differences of the accelerations $\ddot{q}_\alpha - \ddot{q}_\beta$ at $t = t_0$ are transformed as tangent vectors. Consequently,

by Lemma 1.3 the compulsion is defined invariantly. The value of compulsion can be taken for a measure of “deviation” of motions.

Theorem 1.3. *The deviation of conceivable motions from the released motion takes a stationary value on the actual motion.*

The proof is based on application of the well-known rule of Lagrange multipliers.

Usually the matrix A is positive definite (as in natural systems). In this case one can derive from Theorem 1.3 the following.

Corollary 1.5 (Gauss’ principle [42]). *Among conceivable motions the actual motion is least deviated from the released motion.*

Example 1.5. A *mathematical pendulum* of length l is a heavy material point moving without friction along a circle of radius l in a vertical plane. Let φ be the angle between the pendulum and the vertical line (Fig. 1.5). For a fixed state $(\varphi, \dot{\varphi})$ the ends of acceleration vectors a_μ of the conceivable motions of the pendulum lie on the straight line that is at distance $l\dot{\varphi}^2$ from the point m and is parallel to the velocity. The acceleration of the released motion obviously coincides with the acceleration of gravity g . The compulsion $Z = m\langle a_\mu - g, a_\mu - g \rangle / 2$ coincides, up to a constant summand, with the function $m(l\dot{\varphi} + g \sin \varphi)^2 / 2$. The condition that Z be minimum leads to the equation of oscillations of the mathematical pendulum: $l\ddot{\varphi} + g \sin \varphi = 0$.

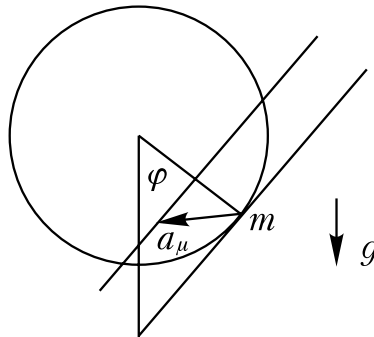

Fig. 1.5.

△

In order to state Hölder’s principle we shall need certain new definitions. Let $\omega \in \Omega$ be a smooth admissible path. In the vector space of variation vector fields $T_\omega \Omega$ we consider the subspace Γ consisting of the fields \widetilde{W} such that the vectors \widetilde{W}_t are virtual velocities for all t . We call a path ω a critical point (in the sense of Hölder) of the action functional F if the restriction of δF to the subspace Γ vanishes.

Theorem 1.4 (Hölder's principle [42]). *An admissible path is a motion of the Lagrangian system with constraints if and only if it is a critical point (in the sense of Hölder) of the action functional.*

This assertion is a simple corollary of Theorem 1.2 and the d'Alembert–Lagrange principle.

Hertz classified Lagrangian systems with linear constraints into *holonomic* and *non-holonomic systems* depending on whether the constraints are *completely integrable* or not. The definition of integrability has an especially simple form in the case of homogeneous constraints that do not depend explicitly on time:

$$a_1(q) \cdot \dot{q} = \cdots = a_m(q) \cdot \dot{q} = 0. \quad (1.35)$$

According to the general definition of constraints the covectors a_1, \dots, a_m are assumed to be linearly independent at all points of M^n . A constraint (1.35) is said to be completely integrable if there exists a smooth $(n - m)$ -dimensional foliation on M^n whose leaves (smooth $(n - m)$ -dimensional submanifolds of M^n) are tangent at all their points to the planes defined by (1.35).

We give one of the versions of Frobenius' criterion for complete integrability of a distribution of tangent planes (1.35): Let $\varphi_s = a_s \cdot dq$ be a 1-form on M^n for each $s = 1, \dots, m$; the constraint (1.35) is completely integrable if and only if the 2-forms $d\varphi_s$, $s = 1, \dots, m$, vanish on the space of admissible velocities.

Let $q: \Delta \rightarrow M^n$ be an admissible path of a system with holonomic constraints. Then the values $q(t)$ belong to some leaf N^{n-m} for all $t \in \Delta$. We introduce the restriction $\widehat{L}: TN^{n-m} \rightarrow R$ of the Lagrangian L to $TN^{n-m} \subset TM^n$.

Proposition 1.9. *An admissible path $q: \Delta \rightarrow M^n$ is a motion of the holonomic system (M^n, L, S) if and only if the path $\widehat{q}: \Delta \rightarrow N^{n-m}$, $\widehat{q}(t) \equiv q(t)$, is a motion of the Lagrangian system (N^{n-m}, \widehat{L}) .*

Thus, holonomic systems are practically indistinguishable from ordinary Lagrangian systems without constraints.

Corollary 1.6. *The motion of a holonomic system is determined by the restriction of the Lagrangian to the manifold $S \subset TM$.*

This is not true, of course, in the non-holonomic case.

The most popular examples of motion with non-integrable constraints are a skate sliding on ice and a ball rolling on a rough surface. In the first case the velocity of the contact point has zero component in the direction perpendicular to the plane of the skate, in the second case, the velocity of the contact point is zero. In conclusion of this section we consider two examples of a “paradoxical” behaviour of non-holonomic systems.

Example 1.6. Consider a skate on an inclined plane with Cartesian coordinates x, y ; we assume the y -axis to be horizontal, and the x -axis directed

downwards. Let (x, y) be the coordinates of the contact point of the “balanced” skate with the plane, and φ its rotation angle measured from the x -axis. The equation of the non-integrable constraint is $\dot{x} \sin \varphi - \dot{y} \cos \varphi = 0$. Choosing the appropriate units of mass, length, and time we can represent the Lagrangian in the form $L = (\dot{x}^2 + \dot{y}^2 + \dot{\varphi}^2)/2 + x$. The corresponding Lagrange’s equations with multipliers can be easily integrated. For example, if initially the angle is $\varphi = 0$ and the skate is rotating with angular velocity $\dot{\varphi}(0) = \omega$, then

$$x = \frac{\sin^2 \omega t}{2\omega^2}, \quad y = \frac{1}{2\omega^2} \left(\omega t - \frac{1}{2} \sin 2\omega t \right), \quad \varphi = \omega t.$$

An interesting feature of this solution is that on average the skate does not slide off from the inclined plane: $0 \leq x(t) \leq 1/2\omega^2$.

Now consider the problem of a homogeneous ball rolling inside a tube standing vertically. It is natural to expect a spiral descent of the ball along a trajectory with increasing steepness. However, actually (if the initial velocity of the centre of the ball is not vertical) the ball will perform harmonic oscillations between two fixed horizontal planes. \triangle

1.3 Hamiltonian Mechanics

1.3.1 Symplectic Structures and Hamilton’s Equations

Let M^{2n} be a smooth even-dimensional manifold. There are several equivalent ways of defining a *symplectic structure* on M . We list the best-known ones.

a) A symplectic structure on M is by definition a closed non-degenerate 2-form ω^2 . By *Darboux’s theorem*, in a small neighbourhood of each point on M the symplectic structure ω^2 can be reduced to the “canonical” form

$$\sum_{i=1}^n dp_i \wedge dq_i$$

in suitable local coordinates $p_1, \dots, p_n, q_1, \dots, q_n$. The local coordinates p, q are usually called *symplectic* or *canonical* coordinates.

The form ω^2 allows one to construct the natural isomorphism of the tangent $T_x M$ and cotangent $T_x^* M$ spaces: a vector $\xi \in T_x M$ is associated with a 1-form $\omega_\xi^1 \in T_x^* M$ by the rule $\omega_\xi^1(\eta) = \omega^2(\eta, \xi)$, $\eta \in T_x M$. Since the 2-form ω^2 is bilinear and non-degenerate, the correspondence $\xi \mapsto \omega_\xi^1$ is indeed a linear isomorphism. Let $I: T_x^* M \rightarrow T_x M$ denote the inverse map. Suppose that H is a smooth function on M (possibly depending on time). Since the differential dH is a covector, $I dH$ is a smooth vector field on M , which is called a *Hamiltonian* vector field. The corresponding differential equation

$$\dot{x} = I dH(x) \tag{1.36}$$

is called *Hamilton's equation*.

If F and G are smooth functions on M , then the smooth function $\omega^2(I dG, I dF)$ is well defined, which is called the *Poisson bracket* of the functions F and G . We denote it by $\{F, G\}$. The Poisson bracket has the following properties:

- 1) it is bilinear,
- 2) it is skew-symmetric,
- 3) $\{F_1 F_2, G\} = F_1 \{F_2, G\} + F_2 \{F_1, G\}$ (the Leibnitz rule),
- 4) $\{\{H, F\}, G\} + \{\{F, G\}, H\} + \{\{G, H\}, F\} \equiv 0$ (the Jacobi identity),
- 5) it is non-degenerate (if a point $x \in M$ is not critical for F , then there exists a smooth function G such that $\{F, G\}(x) \neq 0$).

In symplectic local coordinates p, q we have

$$\{F, G\} = \sum_{i=1}^n (G'_{p_i} F'_{q_i} - G'_{q_i} F'_{p_i}).$$

The Poisson bracket $\{F, G\}$ can be calculated by the formula $dF(I dG)$, which is the value of the covector dF at the vector $I dG$. Consequently, the derivative of the function F along the Hamiltonian vector field $I dH$ is equal exactly to $\{F, H\}$. Thus, Hamilton's equation (1.36) can be rewritten in the equivalent form $\dot{F} = \{F, H\}$. Since the coordinate functions $p_1, \dots, p_n, q_1, \dots, q_n$ form a "complete" set of independent functions, the equations

$$\dot{p}_i = \{p_i, H\}, \quad \dot{q}_i = \{q_i, H\} \Leftrightarrow \dot{p}_i = -H'_{q_i}, \quad \dot{q}_i = H'_{p_i} \quad (1 \leq i \leq n)$$

are closed. They are called the *canonical* Hamilton's equations.

b) According to Dirac the manifold M is equipped with a symplectic structure if there is a map $\{, \}: C^\infty(M) \times C^\infty(M) \rightarrow C^\infty(M)$ satisfying conditions 1–5 in part a).

Let F be a smooth function on M . It follows from conditions 1 and 3 that $v_F = \{F, \cdot\}$ is a derivation, that is, a tangent vector to M . Every tangent vector can be represented in this form. Let G be another smooth function, and let $v_G = \{G, \cdot\}$ be the corresponding tangent vector. We define a 2-form ω^2 by the formula

$$\omega^2(v_G, v_F) = \{F, G\}.$$

This form is clearly bilinear, skew-symmetric, and non-degenerate. The latter follows from the condition that the Poisson bracket is non-degenerate. One can deduce from the Jacobi identity that ω^2 is closed. Thus, the definition of a symplectic structure according to Dirac is equivalent to the definition in part a).

c) Finally, according to the “classical” approach a symplectic structure on M is defined using a *symplectic atlas*, that is, a collection of charts compatible with each other and such that the transition from one chart to another is a *canonical transformation*.

Let P, Q and p, q be local coordinates on M . A transformation of local coordinates $p, q \mapsto P, Q$ is said to be canonical if

$$P dQ - p dq = dS(p, q),$$

where S is some smooth function called a *primitive function* of the canonical transformation.

Remark 1.1. Canonical transformations of local symplectic variables should be distinguished from symplectic maps preserving the symplectic structure. The latter are defined globally, while the former, only in small neighbourhoods of points in M . For example, let $M = \mathbb{R}^2/\mathbb{Z}^2$ be a two-dimensional torus, $\mathbb{R}^2 = \{(p, q)\}$, and $\omega = dp \wedge dq$ the oriented area on M . The map $(p, q) \mapsto (P, Q)$ defined by the formulae $P = p + a, Q = q + b$ ($a, b = \text{const}$) is clearly symplectic, but $P dQ - p dq = a dq$ is not the differential of a single-valued function on M if $a \neq 0$.

It follows from the definition of canonical transformations that the form $\omega_{p, q}^2 = dp \wedge dq$ is well defined on the whole of M . Indeed,

$$\omega_{p, q}^2 = d(p dq) = d(P dQ - dS) = dP \wedge dQ - d dS = \omega_{P, Q}^2.$$

We now give criteria for a transformation $p, q \mapsto P, Q$ to be canonical.

a) Let

$$\Gamma = \begin{pmatrix} \frac{\partial Q}{\partial q} & \frac{\partial Q}{\partial p} \\ \frac{\partial P}{\partial q} & \frac{\partial P}{\partial p} \end{pmatrix}$$

be the Jacobi matrix of the transformation. The transformation is canonical if and only if $\Gamma^\top I \Gamma = I$, where

$$I = \begin{pmatrix} 0 & -E \\ E & 0 \end{pmatrix}$$

is the symplectic unity.

$\beta)$

$$\oint_{\gamma} P dQ = \oint_{\gamma} p dq$$

for any closed contour γ contractible to a point.

$\gamma)$ $\{F, G\}_{P, Q} = \{F, G\}_{p, q}$ for any smooth functions F and G .

This implies, in particular, that canonical transformations preserve the canonical form of Hamilton’s equations. Indeed, $\dot{F}_{P, Q} = \dot{F}_{p, q} = \{F, H\}_{p, q} = \{F, H\}_{P, Q}$.

1.3.2 Generating Functions

Let $g: (p, q) \mapsto (x, y)$ be a canonical change of variables such that

$$\det \left(\frac{\partial x(p, q)}{\partial p} \right) \neq 0. \tag{1.37}$$

Then the equation $x = x(p, q)$ can be resolved (at least locally) with respect to p , and x, q can be regarded as independent variables. Then

$$p = p(x, q), \quad y = y(p, q) = y(p(x, q), q).$$

The condition for the transformation g to be canonical

$$p \, dq - x \, dy = dF(p, q)$$

can be written in the form

$$p \, dq + y \, dx = d(F + xy) = dS(x, q),$$

whence $p = S_{q'}$ and $y = S_{x'}$. It follows from (1.37) that

$$\det \left(\frac{\partial^2 S}{\partial x \partial q} \right) \neq 0. \tag{1.38}$$

The function $S(x, q)$ is called a *generating function* of the transformation g . For example, if g is the identity transformation, then $S = xq$.

Proposition 1.10. *For any function $S(x, q)$ satisfying (1.38) there exists a canonical change of variables $x = x(p, q), y = y(p, q)$ such that S is a generating function of it and $\det(\partial x/\partial p) \neq 0$.*

We note that not all canonical changes of variables satisfy (1.37). Here is a simple example: $x = q, y = -p$. In such cases the method of generating functions can be slightly modified. For example, suppose that the Jacobian $\det(\partial y/\partial p)$ is non-zero. Such canonical transformations are said to be *free*. The function $S_*(y, q) = F(p(y, q), q)$ serves as a generating function: the formulae

$$p = S'_{*q}, \quad x = -S'_{*y}$$

define a free canonical transformation. Proposition 1.10 is again valid for free canonical transformations. These remarks can be generalized.

Proposition 1.11. *Suppose that g is a canonical transformation given by $2n$ functions $x = x(p, q), y = y(p, q)$. We can always take for local independent coordinates one of the 2^n sets of functions $(x_i, y_j, q), i \in I, j \in \{1, 2, \dots, n\} \setminus I$, such that*

$$\frac{\partial(x_i, y_j)}{\partial(p_i, p_j)} \neq 0.$$

The transformation g can be locally reconstructed from the generating function

$$\tilde{S}(x_i, y_j, q) = \sum_{i \in I} x_i y_i + \int (p dq - x dy)$$

by using the relations

$$p = \frac{\partial \tilde{S}}{\partial q}, \quad y_i = \frac{\partial \tilde{S}}{\partial x_i}, \quad x_j = -\frac{\partial \tilde{S}}{\partial y_j}.$$

1.3.3 Symplectic Structure of the Cotangent Bundle

Let N^n be a smooth manifold and let T_q^*N be the cotangent space to N at a point q consisting of all the 1-forms on the tangent space T_qN . The union $\bigcup_{q \in N} T_q^*N = M$ has the natural structure of a smooth manifold of dimension $2n$. It is called the cotangent bundle of N and denoted by T^*N . If $q = (q_1, \dots, q_n)$ are local coordinates on N , then every 1-form is defined by its n components $p = (p_1, \dots, p_n)$ in the basis dq_1, \dots, dq_n . The sets of numbers $p_1, \dots, p_n, q_1, \dots, q_n$ form local coordinates on M .

The symplectic structure of the cotangent bundle T^*N is defined exclusively by the smooth structure of the manifold N . First we define the distinguished 1-form $\omega^1 = p \cdot dq$, which is the value of the covector $p \in T_q^*N$ on the tangent vector $\dot{q} \in T_qN$. In the coordinates p_i, q_i ($1 \leq i \leq n$) this form has the expression $\sum p_i dq_i$; it is called the *action form*. The symplectic structure on M is defined by the 2-form $\omega^2 = d\omega^1$, which is closed and non-degenerate.

Using this symplectic structure one can represent Lagrange's equations defined on TN as Hamilton's equations on T^*N . First we consider this question from the local viewpoint. Let $L(\dot{q}, q, t)$ be a Lagrange function such that

$$\det(L''_{\dot{q}\dot{q}}) \neq 0.$$

We set $p = L'_q$ and regard p as an element of the dual space T_q^*N . This equation can be locally resolved with respect to the velocity \dot{q} . We introduce the function

$$H(p, q, t) = p \cdot \dot{q} - L|_{\dot{q} \rightarrow p},$$

which we call the "local" Hamiltonian. For fixed q and t the function $H(p)$ is the *Legendre transform*¹⁰ of the function $L(\dot{q})$. It is easy to verify that $\det(H''_{pp}) \neq 0$ and $\dot{q} = H'_p$, $L(\dot{q}) = \dot{q} \cdot p - H|_{p \rightarrow \dot{q}}$. Thus, the Legendre transformation is involutive.

Theorem 1.5. *Let $q(t)$ be a solution of Lagrange's equation $[L]_{q(t)} = 0$. Then the functions $q(t)$ and $p(t) = L'_q|_t$ satisfy Hamilton's equations $\dot{p} = -H'_q$, $\dot{q} = H'_p$.*

¹⁰ The "Legendre transform" already appears in Euler's and Clairaut's works.

Using momenta instead of velocities first appears in the works of Lagrange and Poisson.

In order to pass to Hamilton's equations globally we assume that a smooth function $L: TN \times \mathbb{R} \rightarrow \mathbb{R}$ is convex with respect to the velocities, that is, the matrix $(L''_{\dot{q}\dot{q}})$ is positive definite for all \dot{q} , q , and t . We define the "global" Hamiltonian by the formula

$$H(p, q, t) = \sup_{\dot{q}} (p \cdot \dot{q} - L(\dot{q}, q, t)). \tag{1.39}$$

If the Lagrangian, as a function of velocity, grows at infinity faster than a linear function (that is, $L(\dot{x})/|\dot{x}| \rightarrow +\infty$ as $|\dot{x}| \rightarrow \infty$, where $|\cdot|$ is some Riemannian metric on N), then the local Hamiltonian is defined for all p and coincides everywhere with the global one. Consequently, H is a smooth function on $M \times \mathbb{R}$. This function is convex with respect to p , and

$$L(\dot{q}, q, t) = \sup_p (\dot{q} \cdot p - H(p, q, t)). \tag{1.40}$$

Formulae (1.39)–(1.40) imply the convexity inequality $p \cdot \dot{q} \leq H(p) + L(\dot{q})$.

We apply these considerations to natural mechanical systems. Let $|\cdot|$ be a Riemannian metric on the configuration space N . The Lagrange function is $L = T - U$, where $T = |\dot{q}|^2/2$ is the kinetic energy and $U(q)$ is the potential energy of the system. If $|\dot{q}|^2 = A(q)\dot{q} \cdot \dot{q}$, then $p = A\dot{q}$ and therefore

$$H(p, q) = T - U|_{\dot{q} \rightarrow p} = \frac{1}{2}|p|^2 + U,$$

where $|p|^2 = A^{-1}p \cdot p$. The function H coincides with the total energy of the system. In a more general case the Lagrange function contains linear terms:

$$L = \frac{1}{2}|\dot{q}|^2 + \langle v(q), \dot{q} \rangle - U(q),$$

where v is a smooth vector field on N . Then

$$H = \frac{1}{2}|p|^2 - p \cdot v(q) + \frac{1}{2}|v(q)|^2 + U(q).$$

In the variables \dot{q} , q the Hamiltonian function coincides with the total energy: $H = |\dot{q}|^2/2 + U$.

1.3.4 The Problem of n Point Vortices

One should not think that Hamilton's equations appear in mechanics only as a result of applying the Legendre transformation to Lagrange's equations. Let us consider a planar steady flow of an ideal incompressible fluid. Let $v = (a(x, y), b(x, y))$ be the velocity field of its particles in Cartesian coordinates x, y . The incompressibility condition $\operatorname{div} v = 0$ implies that the 1-form

$a dy - b dx$ is the differential of some (in general, multivalued) function $\Psi(x, y)$. Then the equation of motion of a fluid particle can be represented in the form of Hamilton's equation

$$\dot{x} = \Psi'_y, \quad \dot{y} = -\Psi'_x \quad (1.41)$$

with Hamiltonian Ψ . Since on the stream lines, the trajectories of the particles, the function Ψ is constant, Ψ is called the stream function.

In hydromechanics an important role is played by the flow with the stream function

$$\Psi = -\frac{\Gamma}{2\pi} \ln r, \quad r = \sqrt{(x - x_0)^2 + (y - y_0)^2}.$$

This function corresponds to the velocity field

$$v = \frac{\Gamma}{2\pi r} \left(-\frac{y - y_0}{r}, \frac{x - x_0}{r} \right).$$

In this case the flow is said to generate a *vortex* of intensity Γ located at the point (x_0, y_0) . It is easy to see that the intensity of the vortex is equal to the integral

$$\oint a dx + b dy$$

taken along any circle with centre at the point (x_0, y_0) .

If on the plane we are given n point vortices with intensities Γ_s and coordinates (x_s, y_s) , then it is natural to consider the stream function

$$\Psi = -\frac{1}{2\pi} \sum_{s=1}^n \Gamma_k \ln \sqrt{(x - x_s)^2 + (y - y_s)^2}.$$

The motion of a fluid particle with coordinates x, y is described by equation (1.41). By *Thomson's theorem* (see § 1.3.7) the vortices are "frozen" into the ideal fluid and their intensities do not change with time. Consequently¹¹, it is natural to describe the dynamics of the vortices themselves by the system of differential equations

$$\begin{aligned} \dot{x}_s &= \frac{\partial \tilde{\Psi}}{\partial y_s}, & \dot{y}_s &= -\frac{\partial \tilde{\Psi}}{\partial x_s}; \\ \tilde{\Psi} &= -\frac{1}{2\pi} \sum_{k \neq s} \Gamma_k \ln \sqrt{(x_s - x_k)^2 + (y_s - y_k)^2}. \end{aligned} \quad (1.42)$$

If we introduce the function

$$H = -\frac{1}{2\pi} \sum_{k \neq s} \Gamma_s \Gamma_k \ln \sqrt{(x_s - x_k)^2 + (y_s - y_k)^2},$$

¹¹ This argument is of heuristic nature.

then equations (1.42) of the system of point vortices can be written in the form

$$\Gamma_s \dot{x}_s = H'_{y_s}, \quad \Gamma_s \dot{y}_s = -H'_{x_s} \quad (1 \leq s \leq n).$$

These equations are Hamiltonian. The symplectic structure on \mathbb{R}^{2n} with coordinates x_s, y_s is defined by the Poisson bracket

$$\{f, g\} = \sum_s \frac{1}{\Gamma_s} \left(\frac{\partial f}{\partial y_s} \frac{\partial g}{\partial x_s} - \frac{\partial f}{\partial x_s} \frac{\partial g}{\partial y_s} \right).$$

1.3.5 Action in the Phase Space

Again, let $M = T^*N$ and let $H: M \times \Delta \rightarrow \mathbb{R}$ be a smooth Hamiltonian function. The “energy-momentum” 1-form $p dq - H dt$ is well defined on the extended phase space $M \times \Delta$. We consider a smooth path $\omega: [0, 1] \rightarrow M \times \Delta$ whose trajectory in the extended phase space is represented by equations $p = p(t), q = q(t), t_1 \leq t \leq t_2$. The set of all such paths is denoted by $\tilde{\Omega}$. A variation of a path ω (with moving ends) is by definition a map $\hat{\alpha}: (-\varepsilon, \varepsilon) \rightarrow \tilde{\Omega}$ such that

- 1) $\hat{\alpha}(0) = \omega$;
- 2) the map $\alpha: (-\varepsilon, \varepsilon) \times [0, 1] \rightarrow M \times \Delta$ given by the formula $\alpha(u, s) = \hat{\alpha}(u)(s), -\varepsilon < u < \varepsilon, 0 \leq s \leq 1$, is a smooth function of the variables u, s .

We call the functional $F: \tilde{\Omega} \rightarrow \mathbb{R}$ given by the formula

$$F(\omega) = \int_{\omega} p dq - H dt \tag{1.43}$$

the *action in the phase space* along the path ω . The action is differentiable and its differential (variation) can be found by the formula

$$\delta F = \left. \frac{dF(\hat{\alpha}(u))}{du} \right|_{u=0} = (pq' - Ht') \Big|_{t_1}^{t_2} + \int_{t_1}^{t_2} (p' \dot{q} - q' \dot{p} - H' + t' \dot{H}) dt. \tag{1.44}$$

Here prime denotes the derivative with respect to u at $u = 0$.

We denote the set of paths in $\tilde{\Omega}$ with fixed ends by Ω (as in § 1.2). The restriction $F: \Omega \rightarrow \mathbb{R}$ is also differentiable and its variation is given by formula (1.44) in which the first summand is absent.

Theorem 1.6. *A path ω is a critical point of the functional $F: \Omega \rightarrow \mathbb{R}$ if and only if its trajectory is a solution of Hamilton’s equations with Hamiltonian H .*

The principle of stationary action in the phase space appears in explicit form in Poincaré’s works ([41], see also [42]).

There is another approach to the Poincaré variational problem. We write down the action as the integral

$$F = \int_{t_1}^{t_2} (p\dot{q} - H) dt$$

and regard the integrand as a Lagrange function $L: TM \rightarrow \mathbb{R}$. The Euler-Lagrange equations of the variational problem $\delta F = 0$ will just be Hamilton's equations. Indeed,

$$(L'_p)' = 0 = L'_p = \dot{q} - H'_p, \quad (L'_q)' = \dot{p} = L'_q = -H'_q.$$

If M is an arbitrary symplectic manifold, then the action (1.43) is defined only locally (within a single canonical chart on M). Under canonical changes of local coordinates the action $F: \Omega \rightarrow \mathbb{R}$ can change only by a constant. In this sense the action is defined "correctly".

1.3.6 Integral Invariant

Let ω be a smooth closed path in the extended phase space. Points on the trajectory of ω can be regarded as initial conditions for solutions of Hamilton's equations. The solutions with initial conditions on the trajectory of ω form a

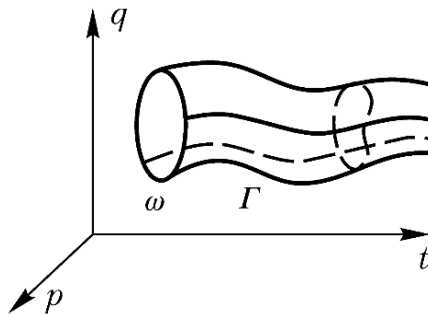

Fig. 1.6. Tube of trajectories

smooth surface Γ in $M \times \Delta$, which is called a *tube of trajectories*. Let $\hat{\alpha}(u)$, $0 \leq u \leq 1$, be a smooth family of closed paths whose trajectories in the extended phase space lie on Γ and are such that $\hat{\alpha}(0) = \omega$.

Theorem 1.7. *The values of the integral*

$$\oint_{\hat{\alpha}(u)} p dq - H dt \tag{1.45}$$

are independent of u .

The integral (1.45) is called the Poincaré–Cartan *integral invariant* [41, 18] (although in variational calculus, and nowadays also in optimal control, it is persistently called the *Hilbert invariant integral*).

◁ Let $s \bmod 1$ be an angle variable parametrizing the closed paths $\widehat{\alpha}$. We consider the action

$$F(\gamma(s)) = \int_{\gamma(s)} p dq - H dt$$

along the paths on the surface Γ that are solutions of Hamilton’s equations and start at points of $\widehat{\alpha}(0) = \omega$ and terminate at points of $\widehat{\alpha}(u)$.

By the first variation formula,

$$\frac{dF(\nu(s))}{ds} = \left(p \frac{\partial q}{\partial s} - H \frac{\partial t}{\partial s} \right) \Big|_0^u.$$

Integrating this equality with respect to s we obtain

$$\int_0^1 \frac{dF(\nu(s))}{ds} ds = \oint_{\widehat{\alpha}(u)} (p dq - H dt) - \oint_{\widehat{\alpha}(0)} (p dq - H dt) = 0.$$

▷

Corollary 1.7. *Let g^t be the phase flow of Hamilton’s equation and let γ be a closed contour in the phase space M . The values of the integral*

$$\oint_{g^t \gamma} p dq \tag{1.46}$$

are independent of t .

Corollary 1.8. *The map $g^t: M \rightarrow M$ is symplectic for all t .*

The integral (1.46) can be given a meaning also in the case when the symplectic structure ω^2 is not exact (that is, the 1-form is not uniquely defined on the whole of M). Indeed, by *Stokes’ formula* we have

$$\oint_{\gamma} p dq = \iint_{\sigma} dp \wedge dq = \iint_{\sigma} \omega^2,$$

where σ is a surface in M with boundary γ .

Corollary 1.9. *The values of the integral*

$$\iint_{g^t \sigma} \omega^2$$

are independent of t .

Since σ is any surface in M , the differential of the map $g^t: M \rightarrow M$ obviously preserves the symplectic structure ω^2 . We consider the exterior powers of the 2-form ω^2 :

$$\omega^4 = \omega^2 \wedge \omega^2, \dots, \omega^{2n} = \omega^2 \wedge \omega^2 \wedge \dots \wedge \omega^2.$$

Since the map $dg^t: TM \rightarrow TM$ preserves the differential forms ω^{2k} , it is obvious that the integrals

$$\int \dots \int_{g^t \sigma^{2k}} \omega^{2k} \quad (1.47)$$

taken over the “moving” $2k$ -dimensional surfaces σ^{2k} are independent of t .

The form ω^{2n} written in canonical coordinates p, q is proportional to the form

$$dp_1 \wedge \dots \wedge dp_n \wedge dq_1 \wedge \dots \wedge dq_n \quad (1.48)$$

with a constant non-zero coefficient. Therefore for $k = n$ it is natural to call the integral (1.47) the volume of the domain σ^{2n} . In any canonical coordinates the phase volume element has the form (1.48) up to a constant factor.

Corollary 1.10. *The phase flow preserves volume in the phase space.*

This important assertion (“*Liouville’s theorem* on conservation of phase volume”) allows one to apply in Hamiltonian mechanics results of ergodic theory (*Poincaré’s recurrence theorem*, *Birkhoff’s mean value theorem*, and so on). It is useful to bear in mind the following remark: if a Hamiltonian system has first integrals F_1, \dots, F_m (which may include the Hamiltonian function H), then the restriction of the phase flow g^t to a non-singular invariant manifold $M_c = \{p, q: F_1 = c_1, \dots, F_m = c_m\}$ preserves some measure with smooth positive density. Namely, one can show that $g^t_{M_c}$ preserves the value of the integral

$$\int_D \frac{d\sigma}{V_m}$$

taken over a “moving” $(2n - m)$ -dimensional domain D on M_c ; here $d\sigma$ is the volume element of M_c as an embedded manifold in \mathbb{R}^{2n} with coordinates p_s, q_s , and V_m is the m -dimensional volume of the parallelepiped with sides $\text{grad } F_1, \dots, \text{grad } F_m$. We note that the form $d\sigma/V_m$ is in fact determined by the symplectic structure alone, that is, by the form $dF_1 \wedge \dots \wedge dF_m$, and is independent of the choice of the metric in \mathbb{R}^{2n} .

1.3.7 Applications to Dynamics of Ideal Fluid

The Euler equation describing the flow of an ideal fluid in a conservative force field has the form

$$\mathbf{a} = -\frac{1}{\rho} \text{grad } p + \text{grad } U. \quad (1.49)$$

Here \mathbf{a} is the acceleration of the particles, ρ the density, p the pressure, and U the potential of the mass forces. In the case of barotropic flows, p and ρ are connected by a relation $p = p(\rho)$ and therefore one can introduce the pressure function

$$P = \int \frac{dp}{\rho}.$$

It is clear from (1.49) that each particle of the fluid behaves as a material point of unit mass placed in the force field with potential $U - P$. In this case the Poincaré–Cartan integral invariant has the form

$$\oint \langle \mathbf{v}, d\mathbf{r} \rangle - E dt,$$

where \mathbf{r} is the position vector of a particle, \mathbf{v} its velocity, and $E = v^2/2 + P - U$ is the Bernoulli function. In the steady flow case, E is constant along the stream lines.

In particular, if we consider a closed “fluid” contour composed of particles at one and the same moment of time, then the integral

$$\oint \langle \mathbf{v}, d\mathbf{r} \rangle,$$

called the *circulation*, will take constant values. This assertion is the well-known Thomson’s theorem on the conservation of circulation, from which the basic results of dynamics of ideal fluid can be derived. We mention two of these results. The first is *Lagrange’s theorem* on the conservation of the potential (irrotational) nature of the flow: if $\text{curl } \mathbf{v} \equiv 0$ at the initial moment of time, then this equality holds at all times. The second is *Helmholtz’ theorem* on the vortex lines (integral curves of the field $\text{curl } \mathbf{v}$) being “frozen-in”: if at some instant particles of the fluid form a vortex line, then these particles form a vortex line at all times.

1.4 Vakonomic Mechanics

In §1.2.5 we considered Lagrangian systems with constraints whose motion obeys the classical d’Alembert–Lagrange principle (equivalent to Gauss’ and Hölder’s principles). In this section we describe another mathematical model of motion of systems with constraints based on a certain natural generalization of Hamilton’s principle of stationary action; this model was named by Kozlov *vakonomic mechanics*. In the case of completely integrable constraints vakonomic mechanics turns out to be identical to ordinary mechanics of holonomic systems. However, if the constraints are non-integrable, then the d’Alembert–Lagrange principle and Hamilton’s principle, being applied to the same Lagrangian system, produce different equations of motion.

1.4.1 Lagrange's Problem

Let M be a smooth manifold, and $L: TM \times \mathbb{R} \rightarrow \mathbb{R}$ a smooth function. Suppose that $f_s: TM \times \mathbb{R} \rightarrow \mathbb{R}$ ($1 \leq s \leq m$) is a set of smooth functions with covectors $f'_{1\dot{q}}, \dots, f'_{m\dot{q}}$ linearly independent at each point. *Lagrange's problem* is the variational problem about the stationary value of the action functional

$$F = \int_{t_1}^{t_2} L dt$$

in the class of curves with fixed ends satisfying the equations

$$f_1 = \dots = f_m = 0. \quad (1.50)$$

In contrast to the variations in Hölder's principle (see § 1.2.5), the variations of admissible paths in Lagrange's problem must again satisfy equations (1.50). But if this requirement is taken literally, then several serious difficulties may arise.

Example 1.7 (Carathéodory). We define a constraint by the equation

$$\dot{x}_2 = \sqrt{1 + \dot{x}_1^2}, \quad (x_1, x_2) \in \mathbb{R}^2. \quad (1.51)$$

If the values of the coordinates $(x_1, x_2) = x$ are fixed at time t_1 , then a smooth curve $t \mapsto (x_1(t), x_2(t))$ satisfying (1.51) is uniquely determined by its projection $x_1(\cdot)$. Here the difference of the values of the x_2 -coordinate at the ends of the curve $x(\cdot)$ coincides with the length of the graph $\{(t, x_1(t))\}$. In particular, if x_1 is a linear function of time, then an admissible curve $x(\cdot)$ has the property that its end $x(t_2)$ cannot be connected with the point $x(t_1)$ by any other admissible curve. \triangle

This difficulty related to the "rigidity" of constraints can be by-passed by slightly modifying the definition of variations.

Definition 1.4. A *variation* of an admissible path $\omega: [t_1, t_2] \rightarrow M$ is a smooth family of paths $\hat{\alpha}(u): [t_1, t_2] \rightarrow M$, $u \in (-\varepsilon, \varepsilon)$, such that

- 1) $\hat{\alpha}(0) = \omega$,
- 2) the values $\alpha(u, t_i)$ do not depend on u ,
- 3) the paths $\alpha(u, t)$ satisfy (1.50) to within $o(u)$.

Lemma 1.4. A smooth vector field $W(t)$ along the admissible path ω is a variation vector field if and only if

- 1) $W_{t_1} = 0$ and $W_{t_2} = 0$,
- 2) $(a_s \cdot W) = b_s \cdot W$ for all $t_1 < t < t_2$, where $a_s = f'_{s\dot{q}}|_{\omega}$ and $b_s = [f_s]|_{\omega}$.

Corollary 1.11. *We have $\int_{t_1}^{t_2} b_s \cdot W dt = 0$ for $1 \leq s \leq m$.*

The variation of the action F is defined in the usual way:

$$\delta F(W) = \left. \frac{dF(\widehat{\alpha}(u))}{du} \right|_{u=0}, \quad W = \left. \frac{d\widehat{\alpha}(u)}{du} \right|_{u=0}.$$

A criterion for the action to be stationary is given by the following result.

Theorem 1.8. *An admissible path $\omega: [t_1, t_2] \rightarrow M$ is a conditional extremal of the action if and only if there exist m smooth functions $\lambda_s: [t_1, t_2] \rightarrow \mathbb{R}$ such that the following equality holds along ω :*

$$[L] = \sum_s \lambda_s [f_s] + \sum_s \dot{\lambda}_s f'_{s\dot{q}}. \quad (1.52)$$

This equation together with the constraint equations (1.50) form a “closed” system for finding the solutions of Lagrange’s problem. Equation (1.52) can be obtained by the *method of Lagrange multipliers*. By introducing the new Lagrangian $\mathcal{L} = L - \sum \lambda_s f_s$ and regarding $\lambda_1, \dots, \lambda_m$ as additional coordinates we reduce Lagrange’s problem to a variational problem without constraints. If the constraint equations are ignored in the new problem, then the Euler–Lagrange equations take the form

$$(\mathcal{L}'_{\dot{q}})' = \mathcal{L}'_q, \quad (\mathcal{L}'_{\lambda})' = \mathcal{L}'_{\lambda}.$$

The first equation coincides with (1.52), and the second, with (1.50). A rigorous proof of Theorem 1.8 is based on application of Lemma 1.4 (see [114]).

Remark 1.2. Theorem 1.8 is not valid for the “classical” variant of Lagrange’s problem where the variations $\widehat{\alpha}(u)$ satisfy exactly the constraint equations for all values of u . In this case the equations of extremals are equations (1.52) with the “amended” Lagrange function $\mathcal{L} = \lambda_0 L - \sum \lambda_s f_s$, where λ_0 is some constant (which may also be zero) and the multipliers $\lambda_0, \lambda_1, \dots, \lambda_m$ are not simultaneously zero. In Example 1.7 it is the case that the constant λ_0 is equal to zero.

1.4.2 Vakonomic Mechanics

The d’Alembert–Lagrange principle is not the only rational definition of motion of Lagrangian systems with constraints. We can replace it by Hamilton’s principle; then the motions of the system with constraints are the conditional extremals of the Lagrange variational problem (in the sense of the definitions in §1.4.1). The equations of motion are then equations (1.50) and (1.52).

We call the mathematical model of motion of Lagrangian systems with constraints based on this extension of Hamilton's principle *vakonomic mechanics*¹² for short. We defer the discussion of the appropriateness of considering this model until § 1.6.

Lagrange's equations (1.52) of vakonomic mechanics differ from the non-holonomic equations

$$[L] = \sum_s \mu_s f'_{s\dot{q}}, \quad f_1 = \cdots = f_m = 0 \quad (1.53)$$

by the summand $\sum_s \lambda_s [f_s]$. If this sum is identically equal to zero (by virtue of the system of (1.50) and (1.52)), then equations (1.52) and (1.53) coincide. In particular, suppose that the system satisfies a set of integrable constraints $g_s(q, t) = 0$ ($1 \leq s \leq m$). These equations can be replaced by the equivalent equations $\dot{g}_s = 0$. Since $[\dot{g}_s] \equiv 0$, in the case of integrable constraints vakonomic mechanics reduces to ordinary holonomic mechanics. We note that, in contrast to non-holonomic mechanics, the motion of a vakonomic Lagrangian system is determined by the restriction of the Lagrangian to the submanifold of TM defined by the constraint equations (1.50).

Lagrange's equations (1.50), (1.52) can be represented in Hamiltonian form. For that we introduce the canonical momenta

$$p = \mathcal{L}'_{\dot{q}} = L'_{\dot{q}} + \sum \lambda_s f'_{s\dot{q}}, \quad (1.54)$$

where the multipliers λ_s are indeterminate for the present. We add to these relations the constraint equations (1.50) and solve system (1.50), (1.54) with respect to \dot{q} and λ . The local solubility condition is

$$\det \left(\begin{array}{c|ccc} A & f'_{1\dot{q}} & \cdots & f'_{m\dot{q}} \\ \hline (f'_{1\dot{q}})^* & & & \\ \vdots & & & \\ (f'_{m\dot{q}})^* & & & 0 \end{array} \right) \neq 0, \quad (1.55)$$

where $A = (\mathcal{L}''_{\dot{q}\dot{q}})$ and the $(f'_{s\dot{q}})^*$ are the covectors $f'_{s\dot{q}}$ written as rows. If the matrix A is non-singular, then inequality (1.55) can be represented in the form

$$\det (f'_{i\dot{q}} A^{-1} f'_{j\dot{q}}) \neq 0.$$

In particular, if the constraints are linear in the velocities, then $\mathcal{L}''_{\dot{q}\dot{q}} = L''_{\dot{q}\dot{q}}$ and condition (1.55) turns into inequality (1.34), which guarantees the deterministic behaviour of a Lagrangian system with constraints obeying the d'Alembert–Lagrange principle (see § 1.2).

¹² Vakonomic mechanics was developed in [329]. We should mention that equation (1.52) appears in the works of Hertz, Hölder, Suslov, and others in connection with the analysis of the applicability of the principle of stationary action (in the spirit of Lagrange's problem) in non-holonomic mechanics (see [42]). It turned out that if the constraints are non-integrable, then the principles of d'Alembert–Lagrange and Hamilton are not equivalent.

Thus, if (1.55) holds, then by the implicit function theorem we have $\dot{q} = \dot{q}(p, q, t)$ and $\lambda = \lambda(p, q, t)$. We introduce by the usual rule the Hamiltonian function

$$H(p, q, t) = p\dot{q}(p, q, t) - L(\dot{q}(p, q, t), q, t).$$

Proposition 1.12. *A smooth path $q: \Delta \rightarrow M$ is a motion of the vakonomic system with Lagrangian L and constraints $f_1 = \dots = f_m = 0$ if and only if the function $q(\cdot)$ together with some “conjugate” function $p(\cdot)$ satisfy Hamilton’s equations*

$$\dot{q} = H'_p, \quad \dot{p} = -H'_q. \tag{1.56}$$

The Hamiltonian function H is degenerate in the momenta: the rank of the Hessian H''_{pp} drops by m . In the natural case (when the Lagrangian is a positive definite quadratic form in the velocities) the map $p \mapsto \dot{q}$ defined by (1.50) and (1.54) is a singular linear map. Since every finite-dimensional vector space can be canonically identified with its second dual space, equations (1.56) can be interpreted as Hamilton’s equations on T^*M .

Example 1.8. We consider a skate on an inclined plane (see Example 1.6 in § 1.2). The Lagrange function of this system is $L = (\dot{x}^2 + \dot{y}^2 + \dot{\varphi}^2)/2 + x$, and the constraint equation is $(\dot{x} \sin \varphi - \dot{y} \cos \varphi) = 0$. The canonical momenta are defined by the formulae

$$\begin{aligned} p_x &= \dot{x} - \lambda \sin \varphi, & p_y &= \dot{y} + \lambda \cos \varphi, & p_\varphi &= \dot{\varphi}; \\ \lambda &= p_y \cos \varphi - p_x \sin \varphi. \end{aligned} \tag{1.57}$$

The Hamiltonian function is

$$H = \frac{1}{2} \left[(p_x \cos \varphi + p_y \sin \varphi)^2 + p_\varphi^2 \right] - x. \tag{1.58}$$

Suppose that initially the angle φ and momentum p_y are equal to zero. Since p_y is a first integral of Hamilton’s equations, we have $p_y \equiv 0$. Consequently, in this case the Hamiltonian takes quite a simple form:

$$H = \frac{1}{2} (p_x^2 \cos^2 \varphi + p_\varphi^2) - x.$$

The canonical equations with this Hamiltonian function are probably non-integrable. But we can draw qualitative conclusions about the sliding of the vakonomic skate. Since $\dot{p}_x = -H'_x = 1$, the momentum p_x is equal to t up to an additive constant. It follows from Hamilton’s equations $\dot{\varphi} = p_\varphi$, $\dot{p}_\varphi = p_x^2 \sin \varphi \cos \varphi$ that

$$\ddot{\varphi} = t^2 \sin \varphi \cos \varphi. \tag{1.59}$$

We obtain from (1.57) the equations for finding the Cartesian coordinates of the contact point

$$\dot{x} = t \cos^2 \varphi, \quad \dot{y} = t \sin \varphi \cos \varphi.$$

It follows from the first equation that the skate is monotonically sliding off down the inclined plane. One can show (see [329]) that almost all the solutions of (1.59) tend to one of the points $\pi/2 + k\pi$ ($k \in \mathbb{Z}$) as $t \rightarrow \infty$. Moreover, there exist the limits

$$\lim_{t \rightarrow \infty} y(t) \quad \text{and} \quad \lim_{t \rightarrow \infty} \frac{1}{t} \int_0^t \dot{x}(s) ds > 0.$$

Consequently, asymptotically the skate goes down along some straight line with non-zero average velocity and tends to position itself across its average motion. It is interesting to compare this motion with the motion of the non-holonomic skate, which under the same initial conditions moves sideways along a cycloid. △

1.4.3 Principle of Determinacy

We consider the motion of a vakonomic natural system with Lagrangian $L = (A\dot{q} \cdot \dot{q})/2 + V(q)$ and with linear constraints $f_s = a_s(q) \cdot \dot{q} = 0$ ($1 \leq s \leq m$) independent of time. The linear map $\Psi_q: T_q^*M \rightarrow T_qM$ defined by (1.50) and (1.54) is singular; its m -dimensional kernel consists of the linear combinations $\sum \mu_s a_s$. Let $\Gamma_q(\dot{q})$ be the m -dimensional plane in T_q^*M that is the full inverse image of a point $\dot{q} \in T_qM$ under the map Ψ_q . We fix an initial state (q_0, \dot{q}_0) allowed by the constraints and consider the family of solutions of Hamilton's equations (1.56) with the initial data $q(0) = q_0, p(0) \in \Gamma_{q_0}(\dot{q}_0)$. If the constraints are completely integrable, then the function $q(t, q(0), p(0))$ – the motion of the vakonomic system – is independent of the choice of the initial momentum in the plane $\Gamma_{q_0}(\dot{q}_0)$. This simple remark admits a converse.

Proposition 1.13. *If the motion $q(t, q(0), p(0))$ is independent of $p(0) \in \Gamma_{q_0}(\dot{q}_0)$ for all admissible states q_0, \dot{q}_0 , then the linear constraints are completely integrable.*

Corollary 1.12. *Vakonomic systems with non-integrable constraints do not obey the principle of determinacy.*

Example 1.9. In the problem of a skate sliding on an inclined plane (see Example 1.8) the initial value of the constant momentum p_y does not affect the initial state of the skate if $\varphi(0) = 0$. But the solutions of Hamilton's equations with the Hamiltonian (1.58) depend essentially on p_y . △

Remark 1.3. The principle of determinacy, though not valid generally, can be satisfied for particular states. One can show that the following “generalized” principle of determinacy holds in vakonomic mechanics: the motion of the system on some time interval uniquely determines all of its past and future motion.

Let $\Psi: T^*M \rightarrow TM$ be the map that coincides on each fibre T_q^*M with the linear map Ψ_q . We say that a function $F: T^*M \rightarrow \mathbb{R}$ is *observable* if there exists a function $G: TM \rightarrow \mathbb{R}$ such that the following diagram is commutative:

$$\begin{array}{ccc} T^*M & \xrightarrow{\Psi} & TM \\ & F \searrow & \swarrow G \\ & & \mathbb{R} \end{array} .$$

A condition for a function $F(p, q)$ to be observable is its invariance under the family of translations $p \mapsto p + \sum \mu_s a_s$. For example, the total energy of the system is observable, while the Lagrange multipliers λ_s are not. We note that the property to be observable is independent of whether the constraints are integrable or not.

Proposition 1.14. *The vector space of observable functions is closed under the Poisson bracket (induced by the standard symplectic structure $dp \wedge dq$) if and only if the constraints are completely integrable.*

In conclusion we mention that the problem of “hidden” parameters – non-observable quantities involved in the description of the dynamics of a system – has been extensively discussed in quantum mechanics precisely in connection with the analysis of the principle of determinacy (see [120]).

1.4.4 Hamilton’s Equations in Redundant Coordinates

In the case of completely integrable constraints, equations (1.56) are Hamilton’s equations of a holonomic system written in *redundant coordinates*. As an example we consider the motion of a material point (m, \mathbf{r}) in Euclidean space E^3 on a smooth regular surface Σ given by an equation $f(\mathbf{r}) = 0$. Suppose that the point is acted upon by a conservative force with potential $U(\mathbf{r})$. We set (according to (1.54))

$$\mathbf{p} = m\dot{\mathbf{r}} + \lambda f'_{\mathbf{r}}, \quad \lambda = \frac{\langle \mathbf{p}, f'_{\mathbf{r}} \rangle}{\langle f'_{\mathbf{r}}, f'_{\mathbf{r}} \rangle}. \tag{1.60}$$

The motion of the point is described by Hamilton’s equations

$$\dot{\mathbf{r}} = H'_{\mathbf{p}}, \quad \dot{\mathbf{p}} = -H'_{\mathbf{r}}; \quad H = \frac{m}{2} \langle \dot{\mathbf{r}}, \dot{\mathbf{r}} \rangle + U = \frac{1}{2m} (\mathbf{p} \times \mathbf{n})^2 + U, \tag{1.61}$$

where \mathbf{n} is the unit normal vector to the surface Σ . Consequently, equations (1.61) are determined by the surface Σ itself and are independent of the form of the equation $f = 0$ defining this surface.

Equations (1.61) have the energy integral H and the “geometric” integral $F = f(\mathbf{r})$. It is obvious that in the standard symplectic structure $d\mathbf{p} \wedge d\mathbf{r}$ the Poisson bracket is zero: $\{H, F\} = 0$. Let $g(\mathbf{r}, \mathbf{r})$ be a first integral of the equations of motion

$$m\ddot{\mathbf{r}} = -U'_{\mathbf{r}} + \lambda f'_{\mathbf{r}}, \quad f(\mathbf{r}) = 0,$$

and let G denote the function g represented in the canonical variables. Clearly, $\{H, G\} = 0$, and it is easy to check that the functions G and F are involutive.

If a contour Γ lies on the hypersurface $\{f = 0\} \subset \mathbb{R}^6$ with coordinates \mathbf{p}, \mathbf{r} , then the Poincaré relative integral invariant

$$\oint_{\Gamma} \langle \mathbf{p}, d\mathbf{r} \rangle$$

is equal, up to the constant factor m , to

$$\oint_{\gamma} \langle \dot{\mathbf{r}}, d\mathbf{r} \rangle, \quad (1.62)$$

where γ is the closed contour in $\mathbb{R}^6\{\mathbf{r}, \dot{\mathbf{r}}\}$ that is the image of the contour Γ under the map (1.60). In hydrodynamics an integral of the form (1.62) is called the velocity circulation over the contour γ .

1.5 Hamiltonian Formalism with Constraints

1.5.1 Dirac's Problem

Let (M, Ω^2) be a symplectic manifold, $H: M \rightarrow \mathbb{R}$ a smooth function, and N a submanifold of M . We call the quadruplet (M, Ω^2, H, N) a *Hamiltonian system with constraints*. The restriction of the symplectic structure Ω^2 to N is denoted by ω^2 , and the restriction of the function H , by F . The form ω^2 is obviously closed, but may turn out to be degenerate (for example, if the dimension of N is odd).

Definition 1.5. A smooth path $x: \Delta \rightarrow M$ with $x(t) \in N$ for all $t \in \Delta$ is called a *motion of the Hamiltonian system* (M, Ω^2, H, N) if $\omega^2(\cdot, \dot{x}(t)) = dF(x(t))$ for all $t \in \Delta$.

Our aim is to describe the set of all motions of a Hamiltonian system with constraints.¹³

If N coincides with M , then the system with constraints is an ordinary Hamiltonian system (see § 1.3) and its motions are the solutions of Hamilton's equations on M . There is one more case where Dirac's problem reduces to solving Hamilton's equations: if the form ω^2 is non-degenerate, then (N, ω^2) is a symplectic submanifold and the motions of the system (M, Ω^2, H, N) are the solutions of Hamilton's equation on N with Hamiltonian function F . Then corresponding to every initial state $x_0 \in N$ there is a unique motion of the system with constraints. In the degenerate case there are two more

¹³ This problem was first considered by Dirac in the 1950s for the purposes of quantum mechanics (see [21]).

possibilities: Dirac’s problem can have several different motions with the initial state x_0 , or have none at all. As we shall see, these two possibilities can indeed occur.

Suppose that the form Ω^2 is exact on M . Then $\Omega^2 = d\Omega^1$ and $\omega^2 = d\omega^1$, where ω^1 is the restriction of the 1-form Ω^1 to N . In the general case (when Ω^2 is not exact) these relations hold locally on M .

Lemma 1.5. *A smooth path $x: [t_1, t_2] \rightarrow N$ is a motion of the system (M, Ω^2, H, N) if and only if $x(\cdot)$ is a critical point of the action functional*

$$\int_{t_1}^{t_2} (\omega^1(\dot{x}) - F) dt$$

in the space of smooth paths on N with fixed ends.

This assertion reduces Dirac’s problem to the study of the Lagrange variational problem (see § 1.4.1) with Lagrangian $L(\dot{x}) = \Omega^1(\dot{x}) - H$ and integrable constraints defined by the manifold N .

We now indicate several explicit formulae that will be used in what follows. Let $x = (p, q)$ be local symplectic coordinates on M and let N be a submanifold defined by a system of equations

$$\Phi_1(p, q) = \dots = \Phi_m(p, q) = 0 \tag{1.63}$$

such that the differentials of the functions Φ_s are linearly independent at each point of N . The equations of the extremals of Lagrange’s problem with Lagrangian $L = p \cdot \dot{q} - H(p, q)$ and constraints (1.63) can be represented in the form of equations with multipliers $[L] = \sum \lambda_s \Phi'_{sx}$, or in the explicit form

$$\dot{q} = H'_p + \sum \lambda_s \Phi'_{sp}, \quad \dot{p} = -H'_q - \sum \lambda_s \Phi'_{sq}. \tag{1.64}$$

To these equations one should add (1.63). Since the Lagrange function L is degenerate in the velocities (it does not depend on \dot{p} at all), the method of § 1.4 cannot be applied to equations (1.64).

We obtain from (1.63) and (1.64) the “compatibility conditions”

$$\dot{\Phi}_i = \{\Phi_i, H\} + \sum \lambda_s \{\Phi_i, \Phi_s\} = 0, \tag{1.65}$$

when $\Phi_s = 0$ for all s . If the matrix of Poisson brackets $(\{\Phi_i, \Phi_j\})$ is non-singular, then equations (1.65) uniquely define the λ_s as functions of p, q . In this case, m is necessarily even and N is a symplectic submanifold of M . The symplectic structure on N is defined by the Poisson bracket

$$\{F_1, F_2\}' = \{F_1, F_2\} + \sum_{i, j=1}^m \{\Phi_i, F_1\} c_{ij} \{\Phi_j, F_2\},$$

where (c_{ij}) is the inverse matrix of $(\{\Phi_i, \Phi_j\})$. One can show that the restriction of the bracket $\{F_1, F_2\}'$ to N depends only on the restrictions of the functions F_1 and F_2 to N . If some of equations (1.65) do not involve the multipliers λ_s , then we obtain new constraint equations $\Psi_j = \{\Phi_j, H\} = 0$, which are usually called *secondary constraints*. In the most general case the secondary constraints are algebraic conditions for solubility of equations (1.65) with respect to the λ_s . The functions Ψ_j should be added to the functions Φ_s ; if these functions form an independent set, then the analysis of the compatibility conditions can be repeated once again. In the end, either we shall arrive at a contradiction (in this case Dirac's problem has no solutions), or system (1.65) becomes consistent for an appropriate choice of the coefficients λ . In the latter case the multipliers λ may be determined non-uniquely. Then the initial conditions do not determine a unique solution of system (1.63)–(1.64).

Example 1.10. Suppose that $m = 1$ and the bracket $\{H, \Phi\}$ is non-zero at all points of N . Then Dirac's problem does not have any solutions, since the compatibility condition (1.65) does not hold. Again suppose that $m = 1$ and $\{H, \Phi\} \equiv 0$ on M . In this case the coefficient λ is an arbitrary smooth function on N , and therefore a whole family of different motions passes through each point of N at the same moment of time. Moreover, there are infinitely many different motions that coincide on an entire interval of the time axis. This cannot happen in vakonomic mechanics (see § 1.4.3). \triangle

Remark 1.4. For solving Dirac's problem it is obviously sufficient to know only the restriction of the Hamiltonian function to the submanifold N .

1.5.2 Duality

If we know the Hamiltonian H and the constraint equations (1.63), then we can pass to the Lagrange function L by the usual rule: $L = \dot{q} \cdot p - H$. We set $\mathcal{H} = H + \sum \lambda_s \Phi_s$. If

$$\det (\mathcal{H}''_{pp}) \neq 0 \quad \text{and} \quad \det \left(\Phi'_{ip} (\mathcal{H}''_{pp})^{-1} \Phi'_{jp} \right) \neq 0,$$

then from the equations

$$\dot{q} = H'_p + \sum \lambda_s \Phi'_{sp}, \quad \Phi_1 = \dots = \Phi_m = 0$$

one can find, at least locally, p as a function of \dot{q} , q . As a result the Lagrangian is a function of the state (q, \dot{q}) degenerate in the velocities. We note that the transition from H to L in Hamiltonian mechanics with constraints is dual to the transition from L to H in vakonomic mechanics (see § 1.4).

Conversely, if we have a Lagrangian $L(\dot{q}, q)$ degenerate in the velocities, then we can introduce the canonical momenta $p = L'_q$ and obtain from these equations several independent relations of the form (1.63). In quantum mechanics these are usually called *primary constraints*. Then the Hamiltonian $H = p \cdot \dot{q} - L$ is introduced, which is defined only on the manifold

$N = \{\Phi_1 = \dots = \Phi_m = 0\}$ in view of the degeneracy of the Lagrangian. As we have already seen, this limitation is inessential. It was a degenerate Lagrangian that Dirac was starting from when developing the Hamiltonian formalism with constraints.

The algebraic aspects of Dirac’s theory of constraints were considered in [85, 86].

1.6 Realization of Constraints

1.6.1 Various Methods of Realization of Constraints

We begin with a simple example. Consider the rectilinear motion of two bodies of masses M and m connected with each other and with the “wall” by elastic springs with coefficients of elasticity k and c (as shown in Fig. 1.7). Let x and

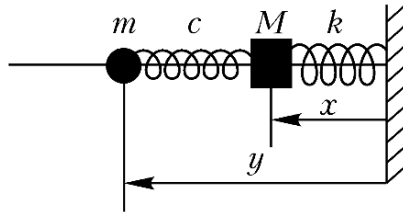

Fig. 1.7.

y be the distances from the “wall” to the points M and m . The motion is described by the simple system of linear equations

$$M\ddot{x} = -kx - c(x - y), \quad m\ddot{y} = -c(y - x).$$

We fix the parameters M, m, c , and let k tend to infinity. Let $x(t, k), y(t, k)$ be the solution of these equations with initial condition $x(0, k) = \dot{x}(0, k) = 0$, and with $y(0, k)$ and $\dot{y}(0, k)$ independent of k . It is obvious that

$$\lim_{k \rightarrow \infty} x(t, k) = 0$$

and the limiting motion

$$\hat{y}(t) = \lim_{k \rightarrow \infty} y(t, k)$$

is a harmonic oscillation with frequency $\omega = \sqrt{c/m}$. In this case the “infinite stiffness” of the spring is equivalent to imposing the holonomic constraint $x = 0$ on the system.

The same constraint can be realized in a different way. For that it is sufficient to let the mass M tend to infinity and assume again that $x(0) = \dot{x}(0) = 0$.

There is another physically evident way of realization of this constraint based on introducing the forces of viscous friction. Suppose that the body of mass M is in addition acted upon by the resistance force $F = -\alpha\dot{x}$, $\alpha = \text{const} > 0$. This summand should be added in the first equation of motion. If $\alpha \rightarrow \infty$, then again $x(t) \rightarrow 0$. Here it is no longer necessary to assume that $x(0) = \dot{x}(0) = 0$. The equality

$$\lim_{\alpha \rightarrow \infty} x(t) = 0$$

will hold for $t > 0$.

We may consider a more complicated case where M and α are simultaneously increasing to infinity, but their ratio α/M tends to a finite value $\mu > 0$. Passing to this limit we simplify the equations of motion to the equations

$$\ddot{x} = -\mu\dot{x}, \quad m\ddot{y} = -c(y - x).$$

These equations again admit solutions $(x, y) = (0, y_0)$ such that $\ddot{y}_0 + \omega^2 y_0 = 0$ with $\omega^2 = c/m$.

Finally, we consider the case where the mass of the second body m is small. Then in the limit the small mass m does not affect the motion of the body M (which will perform harmonic oscillations with frequency $\sqrt{k/M}$). If $c > 0$, then the mass m will clearly follow the motion of the mass M : $y(t) \equiv x(t)$.

However, if the value of c also tends to zero so that $c/m \rightarrow \mu > 0$, then in the limit we shall have a “restricted” two-body problem: the mass M performs harmonic oscillations by the law $x_0(t)$ and the mass m performs forced oscillations in accordance with the equation

$$\ddot{y} + \mu y = \mu x_0(t).$$

These simple observations admit generalizations.

1.6.2 Holonomic Constraints

Let $T(\dot{q}, q)$ be the kinetic energy of a system with n degrees of freedom which is acted upon by a force with components $F_1(\dot{q}, q), \dots, F_n(\dot{q}, q)$ and let Λ be a smooth n_0 -dimensional ($n_0 < n$) submanifold. Let $q_\infty(t)$, $0 \leq t \leq t_0$, be a motion of the constrained system with configuration space Λ , and let $R_\infty(t)$ be the reaction force of the constraint along this motion.

We introduce a function $q \mapsto W(q)$ such that

- a) it is non-negative,
- b) it vanishes on Λ ,

c) at each point of Λ the second differential of W is positive definite on any subspace of dimension $n_1 = n - n_0$ transversal to the manifold Λ .

For example, if the manifold Λ is given by equations $f_k(q) = 0$ ($1 \leq k \leq n_1$) such that the differentials df_k are linearly independent at the points of Λ , then for W we can take the function

$$\sum c_k f_k^2(q),$$

where the c_k are positive constants.

Let $q_N(t)$ be the motion of the system without constraints satisfying the differential equation

$$\left(\frac{\partial T}{\partial \dot{q}}\right)' - \frac{\partial T}{\partial q} = F - N \frac{\partial W}{\partial q} \tag{1.66}$$

and the initial conditions

$$q_N(0) = q_\infty(0), \quad \dot{q}_N(0) = \dot{q}_\infty(0).$$

Theorem 1.9 ([355]). *For sufficiently large N the motion $q_N(t)$ is defined for $0 \leq t \leq t_0$ and the equalities*

$$q_N(t) = q_\infty(t) + O(N^{-1}), \quad \dot{q}_N(t) = \dot{q}_\infty(t) + O(N^{-1/2}) \tag{1.67}$$

hold. For $t_{1,2} \in [0, t_0]$ along the motion $q_N(t)$ we have

$$\int_{t_1}^{t_2} \left(n \frac{\partial W}{\partial q} + R_\infty(t) \right) dt = O(N^{-1/2}). \tag{1.68}$$

By (1.68) we have

$$\lim_{t_1, t_2 \rightarrow \tau} \lim_{N \rightarrow \infty} \frac{1}{t_2 - t_1} \int_{t_1}^{t_2} N \frac{\partial W}{\partial q}(q_N(t)) dt = -R_\infty(\tau).$$

In the general case the limits with respect to time t and the parameter N do not commute, since as a rule there does not exist a limit value for the elastic force $N \cdot \partial W / \partial q$ as $N \rightarrow \infty$.

Example 1.11. We consider the motion of a material point of unit mass on Euclidean plane $\mathbb{R}^2 = \{x, y\}$. Suppose that Λ is given by the equation $y = 0$, and the projections of the force F onto the x - and y -axis are equal to y and 1, respectively. We set $W = y^2/2$. Then equations (1.66) take the form $\ddot{x} = y$, $\ddot{y} = 1 - Ny$. Since $y_N(0) = \dot{y}_N(0) = 0$, we have

$$y_N(t) = \frac{1 - \cos(N^{1/2}t)}{N}.$$

For a fixed t we clearly have

$$y_N(t) = O(N^{-1}), \quad \dot{y}_N(t) = O(N^{-1/2}).$$

But the force

$$-NW' = -Ny_N = \cos(N^{1/2}t) - 1$$

oscillates rapidly (with frequency $N^{1/2}$) around its mean value equal to the reaction force of the constraint $y = 0$. After averaging over time the oscillation is already $O(N^{-1/2})$ and therefore tends to zero as $N \rightarrow \infty$. The x -coordinate describes the motion on the manifold \mathcal{A} . This example shows that estimates (1.67) and (1.68) are best possible. \triangle

The general theorem on the realization of holonomic constraints by elastic forces directed towards the configuration manifold of the constrained system was stated by Courant and was first proved in [521] under the assumption that the forces F are conservative. Generalizations of Courant's theorem were obtained in [104, 300, 578], where passing to the limit was studied in the case where the initial velocity of the system is transversal to the manifold defined by the constraint equations. These papers also use essentially the assumption that the system be conservative.

1.6.3 Anisotropic Friction

We begin with the definition of the forces of viscous friction. We say that a Lagrangian system with Lagrangian $L = (A(q)\dot{q} \cdot \dot{q})/2 - U(q)$ is acted upon by forces of viscous friction if its motion is described by the equation

$$[L] = -F'_{\dot{q}}, \tag{1.69}$$

where F is a non-negative quadratic form in the velocities, which is called the *dissipation function* or Rayleigh's function. The derivative of the total energy of the system is equal to $-2F$ by equation (1.69). If the form F is positive definite (then the friction forces are said to have *total dissipation*), then the energy is monotonically decreasing on all the motions distinct from an equilibrium. We shall consider the friction forces with Rayleigh's function $F_N = -N(a(q) \cdot \dot{q})^2/2$, where a is some covector field and $N = \text{const} > 0$. It is easy to see that the form F_N is degenerate, and the total energy of the system is not decreasing only on those motions $q(\cdot)$ that satisfy the equation

$$a(q) \cdot \dot{q} = 0. \tag{1.70}$$

Of course, such motions that are not equilibria do not always exist. Friction with dissipation function F_N is also called *anisotropic friction*.

Let $q(t, N)$ be the solution of the equation with an initial condition independent of N .

Theorem 1.10. *The limit*

$$\lim_{N \rightarrow \infty} q(t, N) = \widehat{q}(t) \tag{1.71}$$

exists on each finite time interval $0 < t \leq t_0$. The limit function satisfies the system of non-holonomic equations

$$[L] = \lambda a, \quad a(q) \cdot \dot{q} = 0.$$

In particular, $\widehat{q}(t)$ satisfies the linear constraint equation (1.70).

If the initial state (q_0, \dot{q}_0) is chosen in the set of solutions of the equation $a(q) \cdot \dot{q} = 0$, then the limit (1.71) exists for $t = 0$ and the convergence is uniform on every finite time interval. In the general case this convergence is not uniform on the interval $0 < t \leq t_0$.

Theorem 1.10 can be derived from the well-known Tikhonov’s theorem on singularly perturbed systems (see [144, 304]). The idea of realization of constraints that are linear in the velocities by the forces of viscous friction and the first results in this direction are due to Carathéodory [161].

We consider from this viewpoint the problem of non-holonomic mechanics about the rolling of a homogeneous ball inside a vertically standing tube of large radius, which was mentioned in § 1.2. We now assume that the ball can slip, and let \mathbf{v} be the non-zero velocity of the contact point. We introduce a force of viscous friction applied to the contact point and equal to $-k\mathbf{v}$, where $k = \text{const} > 0$. For sufficiently large values of k the motion of this ball will be close to the rolling of the non-holonomic ball and therefore, at least during an initial period of time, one can observe the ball with friction moving upwards in the tube.

1.6.4 Adjoint Masses

We consider the motion of a natural system with Lagrangian

$$L_N = \frac{1}{2}(A(q)\dot{q} \cdot \dot{q}) + \frac{N}{2}(a(q) \cdot \dot{q})^2 - U(q)$$

depending on a parameter $N \geq 0$. Again, here $a(q)$ is a non-zero covector field defined on the configuration space.

Let $q(t, N)$ be the motion with initial state q_0, \dot{q}_0 such that $a(q_0) \cdot \dot{q}_0 = 0$.

Theorem 1.11 (see [329]). *The limit*

$$\lim_{N \rightarrow \infty} q(t, N) = \widehat{q}(t)$$

exists on each finite time interval $0 \leq t \leq t_0$. The limit function is an extremal of the Lagrange variational problem about the stationary value of the functional

$$\int_{t_1}^{t_2} L_0 dt, \quad L_0 = \frac{1}{2}A\dot{q} \cdot \dot{q} - U,$$

with linear constraint $a \cdot \dot{q} = 0$.

Consequently, the limit motion $\widehat{q}(\cdot)$ is a motion of the vakonomic system with Lagrange function L_0 and constraint $a \cdot \dot{q} = 0$.

We now examine this passage to the limit in more detail. For $N \geq 0$ we introduce in the usual way the canonical momenta

$$p = A\dot{q} + N(a \cdot \dot{q})a.$$

Solving this equation with respect to the velocities

$$A\dot{q} = p - \frac{A^{-1}p \cdot a}{A^{-1}a \cdot a} a + \frac{1}{1 + N(A^{-1}a \cdot a)} \frac{A^{-1}p \cdot a}{A^{-1}a \cdot a} a$$

we see that as $N \rightarrow \infty$ this equation turns into the equality

$$A\dot{q} = p - \frac{A^{-1}p \cdot a}{A^{-1}a \cdot a} a,$$

which is used in vakonomic mechanics for defining the momenta.

Assuming $N > 0$ we consider the motions of the holonomic system with initial data

$$q(0) = q_0, \quad p_\alpha(0) = p_0 + \alpha a, \quad \alpha \in \mathbb{R},$$

where $p_0 = A\dot{q}_0$ and $a(q_0) \cdot \dot{q}_0 = 0$. When $\alpha = 0$, we obtain the initial conditions mentioned in Theorem 1.11. For a fixed value of α the initial conditions $q(0)$ and $\dot{q}_\alpha(0) = A^{-1}(q_0)p_\alpha(0)$ satisfy the equation $a \cdot \dot{q} = 0$ to within a quantity of order $1/N$.

The Hamiltonian of the holonomic system with Lagrangian L_N is equal to $H_N = H_0 + O(1/N)$, where H_0 is the vakonomic Hamiltonian function (see § 1.4). Consequently, for fixed α we have the limit

$$\lim_{N \rightarrow \infty} q_\alpha(t, N) = \widehat{q}_\alpha(t), \tag{1.72}$$

which represents one of the motions of the vakonomic system with Lagrangian L_0 and constraint $a \cdot \dot{q} = 0$.

For $N \rightarrow \infty$ the initial state $q(0)$, $\dot{q}_\alpha(0)$ is independent of α , but in the case of non-integrable constraints the limit (1.72) depends essentially on the parameter α (see § 1.4). Thus, when N is large, errors of order $1/N$ in the initial conditions can generate finite deviations over times $t \sim 1$. This is one of the qualitative explanations of the non-deterministic behaviour of vakonomic systems.

Example 1.12. We now show how one can physically realize the motion of the vakonomic skate on an inclined plane studied in § 1.4. For that we consider the motion of an elongated weightless elliptic plate with rigidly attached points of positive mass in a boundless ideal fluid (see Fig. 1.8). Suppose that the points are acted upon only by the gravitational force. The symmetry of the problem allows the motions such that the x -axis is horizontal and the y - and z -axes lie invariably in some vertical plane.

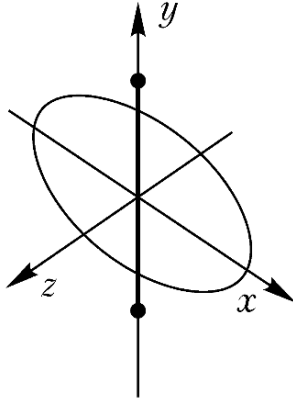

Fig. 1.8.

Let ω be the projection of the angular velocity of the body onto the x -axis, and u, v the projections of the velocity of the centre of mass onto the y - and z -axes. First we consider the motion of an ellipsoid

$$\frac{x^2}{a^2} + \frac{y^2}{b^2} + \frac{z^2}{c^2} = 1$$

in a homogeneous fluid with density ρ . The kinetic energy of the fluid is equal to

$$\frac{1}{2}(A\omega^2 + Bu^2 + Cv^2), \tag{1.73}$$

where

$$A = \frac{1}{5} \frac{(b^2 - c^2)^2(\gamma_0 - \beta_0)}{2(b - c^2) + (b^2 + c^2)(\beta_0 - \gamma_0)} \frac{4}{3} \pi \rho abc, \quad B = \frac{\beta_0}{2 - \beta_0} \frac{4}{3} \pi \rho abc,$$

$$C = \frac{\gamma_0}{2 - \gamma_0} \frac{4}{3} \pi \rho abc, \quad D = \sqrt{(a^2 + \lambda)(b^2 + \lambda)(c^2 + \lambda)},$$

$$\beta_0 = abc \int_0^\infty \frac{d\lambda}{(b^2 + \lambda)D}, \quad \gamma_0 = abc \int_0^\infty \frac{d\lambda}{(c^2 + \lambda)D}.$$

These formulae can be found, for example, in Lamb's book [366].

We let c tend to zero and set $b = \varepsilon, a = \varepsilon^{-\alpha}$. Assuming ε to be small we can obtain from these relations the following asymptotic formulae:

$$A \sim \frac{2}{15} \pi \rho \varepsilon^{4-\alpha}, \quad B = 0, \quad C \sim \frac{4}{3} \pi \rho \varepsilon^{2-\alpha}.$$

Thus, if $2 < \alpha < 4$, then $A \rightarrow 0$ and $C \rightarrow \infty$ as $\varepsilon \rightarrow 0$.

The kinetic energy of the system "body + fluid" has the same form (1.73), but one should add to A the moment of inertia of the body with respect to

the x -axis, and to B and C , the mass of the body. As a result, as $\varepsilon \rightarrow 0$, the quantities A and B will tend to finite limits, and $C \rightarrow \infty$. Thus, we find ourselves under the conditions of the theorem: as $\varepsilon \rightarrow 0$, the motion of the elliptic plate with initial velocity $v(0) = 0$ tends to the motion of the limiting vakonomic system. \triangle

1.6.5 Adjoint Masses and Anisotropic Friction

We consider a multidimensional natural mechanical system with Lagrangian

$$L_N = \frac{1}{2}(A(q)\dot{q} \cdot \dot{q}) + \frac{\alpha N}{2}(a(q) \cdot \dot{q})^2 + V(q).$$

Suppose that, apart from conservative forces with force function V , the system is subjected to the forces of anisotropic friction with Rayleigh's dissipation function

$$F_N = \frac{\beta N}{2}(a(q) \cdot \dot{q})^2.$$

The equation of motion has the form of Lagrange's equation

$$[L] = -F'_{N\dot{q}}.$$

Fixing the values of the parameters $\alpha > 0$, $\beta \geq 0$ we let N tend to infinity.

Let $q(t, N)$ be the solutions of the equation of motion with initial state independent of N and satisfying the equation $a \cdot \dot{q} = 0$.

Theorem 1.12 (see [331]). *The limit*

$$\lim_{N \rightarrow \infty} q(t, N) = \hat{q}(t)$$

exists on each finite time interval. The limit motion $\hat{q}(\cdot)$ together with a certain "conjugate" function $\hat{p}(\cdot)$ satisfy the differential equations

$$\dot{p} = -\frac{\partial H}{\partial q} - \mu \frac{A^{-1}p \cdot a}{A^{-1}a \cdot a} a, \quad \dot{q} = \frac{\partial H}{\partial p}; \quad \mu = \frac{\beta}{\alpha}, \quad (1.74)$$

where $H(p, q)$ is the Hamiltonian function of the vakonomic system with Lagrangian L_0 and constraint $a \cdot \dot{q} = 0$.

It follows from the second equation (1.74) that the limit motion $\hat{q}(\cdot)$ satisfies the equation $a \cdot \dot{q} = 0$.

For $\beta = 0$ Theorem 1.12 coincides with Theorem 1.11. In another limiting case where the ratio $\mu = \beta/\alpha$ is large, equations (1.74) become degenerate. Following the general method of studying such equations, for $\alpha = 0$ we obtain from (1.74) the "simplified" equation

$$\lambda = \frac{A^{-1}p \cdot a}{A^{-1}a \cdot a} = 0.$$

Differentiating the equations $A\dot{q} = p - \lambda a$ with respect to time and using the condition $\lambda = 0$ we obtain

$$(L'_{0\dot{q}})(A\dot{q}) = \dot{p} - \dot{\lambda}a - \lambda\dot{a} = -H'_q - \dot{\lambda}a = L'_{0q} - \dot{\lambda}a.$$

This relation together with the constraint equation form a closed system of non-holonomic equations. Using Tikhonov's theorem one can show that the solutions of (1.74) indeed tend to solutions of the non-holonomic equations as $\mu \rightarrow +\infty$.

For each fixed value of the parameter μ equations (1.74) can be regarded as the equations of motions of the mechanical system with Lagrangian function L_0 and constraint $a \cdot \dot{q} = 0$. Thus, we have a whole family of intrinsically consistent mathematical models of motion. Each of them is a synthesis of traditional non-holonomic mechanics based on the d'Alembert–Lagrange principle and vakonomic dynamics based on Hamilton's variational principle. The question of the choice of a model in each concrete case can be answered only by experiments. A discussion of these problems can be found in [331].

1.6.6 Small Masses

In conclusion we discuss the validity of Dirac's generalized Hamiltonian formalism. As already mentioned in § 1.5, constraints in the phase space arise, for example, when the Lagrangian is degenerate in the velocities. In this connection we consider the holonomic system with Lagrangian function

$$L_\varepsilon = L_0(\dot{q}, q, Q) + \frac{\varepsilon \dot{Q}^2}{2} + \varepsilon L_1(\dot{q}, q, Q, \varepsilon); \quad q \in \mathbb{R}^n, \quad Q \in \mathbb{R},$$

where ε is a small parameter. The function L_0 is assumed to be non-degenerate in \dot{q} .

For $\varepsilon = 0$ we have a degenerate system. The equation $P = 0$, where $P = L'_{0\dot{Q}}$, serves as a primary constraint (in the sense of Dirac). The compatibility condition gives us the secondary constraint

$$\{P, H_0\} = -H'_{0Q} = 0, \tag{1.75}$$

where $H_0(p, q, Q) = p \cdot \dot{q} - L_0|_{\dot{q} \rightarrow p}$.

Suppose that $Q = f(p, q)$ is a solution of equation (1.75). Then the secondary constraint can be represented in the form of the equation $\Psi = Q - f(p, q) = 0$; here $\{P, \Psi\} = -1 \neq 0$.

Dirac's Hamiltonian \mathcal{H} is the sum $H_0 + \lambda P + \mu(Q - f)$; the coefficients λ and μ can be uniquely determined from the compatibility conditions

$$\{P, \mathcal{H}\} = \{P, H_0\} - \mu = 0, \quad \{Q - f, \mathcal{H}\} = -\{f, H_0\} - \lambda = 0.$$

Hence, $\mu = -H'_{0Q}$, $\lambda = \{H_0, f\}$. Hamilton's equations with constraints obviously take the form

$$\dot{p} = -\widehat{H}'_{0q}, \quad \dot{q} = \widehat{H}'_{0p}, \quad P = 0, \quad Q = f, \tag{1.76}$$

where $\widehat{H}_0(p, q) = H_0(p, q, Q)|_{Q=f}$. The Hamiltonian function of the full system (for $\varepsilon \neq 0$) is equal to $H_0(p, q, Q) + P^2/2\varepsilon + \varepsilon H_1(p, q, Q, \varepsilon)$. The corresponding canonical equations are

$$\begin{aligned} \dot{p} &= -H'_{0q} - \varepsilon H'_{1q}, & \dot{q} &= H'_{0p} + \varepsilon H'_{1p}, \\ \dot{P} &= -H'_{0Q} - \varepsilon H'_{1Q}, & \dot{Q} &= P/\varepsilon. \end{aligned} \quad (1.77)$$

Proposition 1.15. *If $H''_{0QQ}|_{Q=f} \neq 0$, then equations (1.77) admit a unique solution in the form of formal power series in ε*

$$\begin{aligned} p &= p_0(t) + \varepsilon p_1(t) + \cdots, & q &= q_0(t) + \varepsilon q_1(t) + \cdots, \\ P &= \varepsilon P_1(t) + \cdots, & Q &= f(p_0(t), q_0(t)) + \varepsilon Q_1(t) + \cdots, \end{aligned} \quad (1.78)$$

where $p_0(t), q_0(t)$ is a prescribed solution of equations (1.76).

Unfortunately, these series do not always converge. But, as shown in [208], for an appropriate choice of the initial conditions the series (1.78) are asymptotic for the solutions of system (1.77). In the case where the function H_0 is independent of Q , equations (1.77) cease to be singular: one should use the new variable P/ε instead of the momentum P . Then the solutions of these equations can be represented in the form of converging power series, and the initial conditions $Q(0)$ and $\dot{Q}(0)$ can be arbitrary. This is exactly the case in the “restricted” n -body problem, when the mass of one of the bodies tends to zero.

Thus, Dirac’s mechanics can be interpreted as mechanics of small masses. On the contrary, vakonomic mechanics is convenient for describing the dynamics of large masses.

The results of this section may be regarded as a justification of our theoretical constructions relating to dynamics of mechanical systems with constraints.

The n -Body Problem

2.1 The Two-Body Problem

2.1.1 Orbits

Suppose that two points (\mathbf{r}_1, m_1) and (\mathbf{r}_2, m_2) interact with each other with potential energy $U(|\mathbf{r}_1 - \mathbf{r}_2|)$, so that the equations of motion have the form

$$m_1 \ddot{\mathbf{r}}_1 = -\frac{\partial U}{\partial \mathbf{r}_1}, \quad m_2 \ddot{\mathbf{r}}_2 = -\frac{\partial U}{\partial \mathbf{r}_2}.$$

Proposition 2.1. *The relative position vector $\mathbf{r} = \mathbf{r}_1 - \mathbf{r}_2$ in the two-body problem varies in the same way as for the motion of a point of mass $m = m_1 m_2 / (m_1 + m_2)$ in the central force field with potential $U(|\mathbf{r}|)$.*

If

$$\boldsymbol{\xi} = \frac{m_1 \mathbf{r}_1 + m_2 \mathbf{r}_2}{m_1 + m_2}$$

is the centre of mass of the points m_1 and m_2 , then obviously

$$\mathbf{r}_1 = \boldsymbol{\xi} + \frac{m_2}{m_1 + m_2} \mathbf{r}, \quad \mathbf{r}_2 = \boldsymbol{\xi} - \frac{m_1}{m_1 + m_2} \mathbf{r}.$$

It follows from these formulae that in a barycentric frame of reference the trajectories of the material points are similar planar curves (with similarity ratio m_2/m_1). Thus, the problem reduces to studying the single equation

$$m \ddot{\mathbf{r}} = -\frac{\partial U}{\partial \mathbf{r}}, \quad \mathbf{r} \in \mathbb{R}^3.$$

Let x, y be Cartesian coordinates in the plane of the orbit. Then $K_z = m(xy - y\dot{x}) = \text{const}$. In polar coordinates $x = r \cos \varphi$, $y = r \sin \varphi$ we clearly have $K_z = mr^2 \dot{\varphi}$. Consequently, $r^2 \dot{\varphi} = c = \text{const}$. If $c = 0$, then $\varphi = \text{const}$ (the point moves along a straight line). We assume that $c \neq 0$. Then φ is a

monotonic function of t , and therefore locally there exists the inverse function $t = t(\varphi)$. As the point m moves, its position vector sweeps out some curvilinear sector of area

$$S(t) = \frac{1}{2} \int_{\varphi(0)}^{\varphi(t)} r^2 d\varphi = \frac{1}{2} \int_0^t r^2 \dot{\varphi} dt = \frac{ct}{2}.$$

Thus, $\dot{S} = c/2 = \text{const}$ (the “sector” velocity is constant). This fact is usually referred to as the *area integral* or *Kepler’s second law*, and the constant c is called the *area constant*.

Proposition 2.2 (Newton). *For a fixed value of the area constant c we have*

$$m\ddot{r} = -\frac{\partial U_c}{\partial r}, \quad \text{where } U_c = U + \frac{mc^2}{2r^2} \quad (r > 0). \quad (2.1)$$

This equation describes the motion of a point of mass m along the straight line $\mathbb{R} = \{r\}$ under the action of the conservative force with potential U_c . We can integrate this equation by quadratures using the energy integral

$$\frac{m\dot{r}^2}{2} + U_c = h.$$

The function U_c is called the *effective* (or *amended*, or *reduced*) *potential*.

Using the energy and area integrals we can find the equation of orbits without solving (2.1). Indeed, since $\dot{r} = \sqrt{2(h - U_c)/m}$ and $r^2\dot{\varphi} = c$, we have

$$\frac{dr}{d\varphi} = \frac{dr}{dt} \frac{dt}{d\varphi} = \frac{r^2}{c} \sqrt{\frac{2(h - U_c)}{m}}.$$

Integrating this equation we obtain

$$\varphi = \int \frac{c dr}{r^2 \sqrt{\frac{2(h - U_c)}{m}}}.$$

In calculations of orbits it is sometimes useful to bear in mind the following proposition.

Proposition 2.3 (Clairaut). *Let $\rho = 1/r$ and let $\rho = \rho(\varphi)$ be the equation of the orbit. Then*

$$m \frac{d^2 \rho}{d\varphi^2} = -\frac{1}{c^2} \frac{d}{d\rho} U_c \left(\frac{1}{\rho} \right).$$

For fixed values of h and c the orbit is contained in the region

$$B_{c, h} = \left\{ (r, \varphi) \in \mathbb{R}^2 : U + \frac{mc^2}{2r^2} \leq h \right\},$$

which is the union of several annuli. Suppose that h is a regular value of the effective potential U_c and suppose that the region $B_{c,h}$ is the annulus $0 < r_1 \leq r \leq r_2 < \infty$. We claim that in this case $r(t)$ is a periodic function of time, and

$$\min r(t) = r_1, \quad \max r(t) = r_2.$$

For the proof we set

$$u = \frac{\pi}{\tau} \int_{r_1}^r \frac{dx}{\sqrt{\frac{2}{m}(h - U_c(x))}}, \quad \tau = \int_{r_1}^{r_2} \frac{dx}{\sqrt{\frac{2}{m}(h - U_c(x))}}.$$

It is obvious that $r(u)$ is a periodic function of u with period 2π and that $\dot{u} = \pi/\tau = \text{const}$. The period of the function $r(\cdot)$ is clearly equal to 2τ .

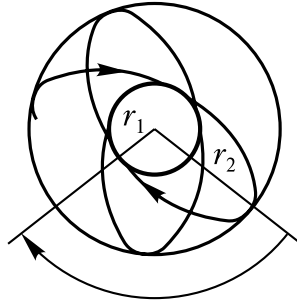

Fig. 2.1. Orbit in a central field

The angle φ changes monotonically (of course, if $c \neq 0$). The points on the orbit that are least distant from the centre are called *pericentres*, and the most distant, *apocentres*. The orbit is symmetric with respect to the straight lines passing through the point $r = 0$ and the pericentres (apocentres). The angle Φ between the directions to the adjacent apocentres (pericentres) is called the *apsidal angle*. The orbit is invariant under the rotation by the angle Φ . If the apsidal angle

$$\Phi = 2 \int_{r_1}^{r_2} \frac{c \, dr}{r^2 \sqrt{\frac{2}{m}(h - U_c)}}$$

is commensurable with π , then the orbit is closed. Otherwise it fills the annulus $B_{c,h}$ everywhere densely. If $r_2 = \infty$, then the orbit is unbounded.

The motion of the point along a circle $r = r_0$ is called a *relative equilibrium*. It is obvious that such a motion is uniform and the values of r_0 coincide with the critical points of the effective potential U_c . If the function U_c has a local minimum at a point $r = r_0$, then the corresponding circular motion is orbitally stable.

Theorem 2.1 (Bertrand). *Suppose that for some $c \neq 0$ there is a stable relative equilibrium and the potential U_c is analytic for $r > 0$. If every orbit sufficiently close to a circular one is closed, then up to an additive constant U is either γr^2 or $-\gamma/r$ (where $\gamma > 0$).*

In the first case the system is a harmonic oscillator; the orbits are ellipses centred at the point $r = 0$. The second case corresponds to the gravitational attraction. The problem of the motion of a point in the force field with potential $U = -\gamma/r$ is usually called *Kepler's problem*.

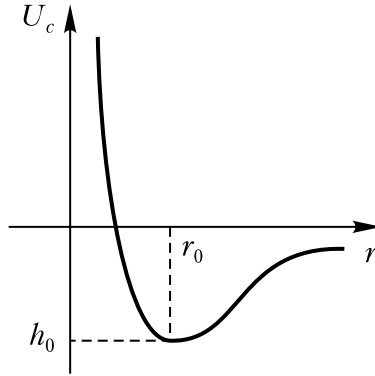

Fig. 2.2. Effective potential of Kepler's problem

The effective potential of Kepler's problem is

$$U_c = \frac{c^2}{2r^2} - \frac{\gamma}{r}.$$

According to *Clairaut's equation* in Proposition 2.3,

$$\frac{d^2\rho}{d\varphi^2} = -\rho + \frac{\gamma}{c^2}.$$

This linear non-homogeneous equation can be easily solved:

$$\rho = A \cos(\varphi - \varphi_0) + \frac{\gamma}{c^2} = \frac{1}{p}(1 + e \cos(\varphi - \varphi_0)), \quad (2.2)$$

where e and φ_0 are some constants and $p = c^2/\gamma > 0$. Hence,

$$r = \frac{p}{1 + e \cos(\varphi - \varphi_0)}$$

and therefore the orbits of Kepler's problem are conic sections with a focus at the centre of attraction (*Kepler's first law*).

Another proof of this law (based on the amazing duality between the orbits of Newtonian gravitation and Hooke's ellipses in the theory of small oscillations) is given below.

For fixed $c \neq 0$ there exists a unique relative equilibrium $r_0 = c^2/\gamma$. Its energy $h_0 = -\gamma^2/2c^2$ is minimal. Using the simple formula

$$v^2 = \dot{r}^2 + r^2\dot{\varphi}^2 = c^2(\rho'^2 + \rho'^2), \quad \rho' = \frac{d\rho}{d\varphi},$$

we can represent the energy integral in the form

$$\frac{c^2}{2}(\rho'^2 + \rho^2) - \gamma\rho = h.$$

Substituting into this formula the orbit's equation (2.2) we obtain the expression for the eccentricity $e = \sqrt{1 + 2c^2h/\gamma^2}$. Since $h \geq h_0 = -\gamma^2/2c^2$, the eccentricity takes only real values.

If $h = h_0$, then $e = 0$ and the orbit is circular. If $h_0 < h < 0$, then $0 < e < 1$; in this case the orbit is an ellipse. If $h = 0$, then $e = 1$ and the orbit is a parabola. For $h > 0$ we have $e > 1$; in this case the point moves along one of the branches of a hyperbola.

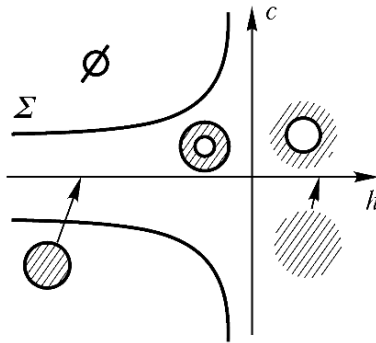

Fig. 2.3.

Fig. 2.3 depicts the *bifurcation set* Σ in the plane of the parameters c, h . The set Σ consists of the curve $h = -\gamma^2/2c^2$ and the two coordinate axes $c = 0$ and $h = 0$. The regions of possible motion $B_{c,h}$ (shaded areas in the figure) change the topological type at the points of Σ .

In the case of harmonic oscillator the period of revolution in an orbit is independent of the initial state. This is not the case in Kepler's problem. For elliptic motions "*Kepler's third law*" holds: $a^3/T^2 = \gamma/4\pi^2 = \text{const}$, where a is the major semiaxis of the ellipse and T is the period of revolution. Since

$$a = \frac{p}{1 - e^2} = \frac{\gamma}{2|h|},$$

the period depends only on the energy constant.

We shall now regard the Euclidean plane where the motion takes place as the plane of complex variable $z = x + iy$.

Proposition 2.4 (Bohlin). *The conformal map $w = z^2$ transforms the trajectories of a Hooke (linear) oscillator (ellipses with centre at zero) into Keplerian ellipses (with a focus at zero).*

◁ Zhukovskij's function $z = \xi + 1/\xi$ transforms the circles $|\xi| = c$ into arbitrary ellipses ($x = (c+1/c) \cos \varphi$, $y = (c-1/c) \sin \varphi$) with centre at zero. But $w = (1+1/\xi)^2 = \xi^2 + 1/\xi^2 + 2$ for such an ellipse; hence the map $\xi^2 \mapsto w$ is also Zhukovskij's function, but with an additional summand 2. It is easy to calculate that the distance from the centre to a focus of such an ellipse is equal to 2 for any c , so that adding 2 shifts the centre to a focus, as required. (The semiaxes $c + 1/c = a$, $c - 1/c = b$ give the square of the distance from the centre to a focus equal to $a^2 - b^2 = 4$.) ▷

This transformation of oscillatory orbits into Keplerian orbits is a special case of the following amazing fact.

Theorem 2.2 (Fouré). *A conformal map $w \mapsto W(z)$ transforms the orbits of motion in the field with potential energy $U(z) = |dw/dz|^2$ (for the total energy constant h) into the orbits of motion in the field with potential energy $V(w) = -|dz/dw|^2$ (for the total energy constant $-1/h$).*

◁ The easiest way to prove this theorem is to compare the Lagrangians of the corresponding Maupertuis variational principles; see Ch. 4. (Incidentally, this comparison shows that the result remains valid also for the quantum-mechanical Schrödinger equation, where too there are “dual” variational principles.) According to Maupertuis' principle for natural systems (see §4.1) a trajectory on the plane of complex variable z is a stationary curve for the length functional in the Jacobi metric, that is, in the Riemannian metric with length element

$$|ds| = \sqrt{2(h - U(z))} |dz|.$$

Passing to the plane of variable w we can write down the same length functional as the length in the metric with element

$$|ds| = \frac{|dw|}{\sqrt{U}} \sqrt{2(h - U)} = |dw| \sqrt{2\left(\frac{h}{U} - 1\right)} = \sqrt{h} \sqrt{2(h' - V(w))} |dw|,$$

where $h' = -1/h$ and $V(w) = -1/U(z)$. Up to the constant factor \sqrt{h} , we have obtained the metric for the potential energy V and the kinetic energy $|dw|^2/2$. Therefore our conformal map transforms the trajectories of motion with potential energy $U(z)$ into the trajectories of motion with potential energy $V(w)$, as required. ▷

Example 2.1. The conformal map $w = z^\alpha$ transforms the orbits of motion in a planar central field with a homogeneous force of degree a into the orbits of motion in a planar central field with a homogeneous force of the dual degree b , where $(a+3)(b+3) = 4$. For example, Hooke's force (linear oscillator) corresponds to $a = 1$, and Newton's gravitational force corresponds to $b = -2$, so that these forces are dual.

The exponent α is a linear function of the degree: $\alpha = (a + 3)/2$. But the theorem can also be applied to $w = e^z$ (or $w = \ln z$). \triangle

2.1.2 Anomalies

To solve Kepler's problem completely it remains to determine the law of motion along the already known orbits. We choose the coordinate axes x and y along the major axes of the conic section representing the orbit. The equation of the orbit can be represented in the following parametric form:

$$\begin{aligned} x &= a(\cos u - e), & y &= a\sqrt{1 - e^2} \sin u & (0 \leq e < 1) & \text{if } h < 0; \\ x &= a(\cosh u - e), & y &= a\sqrt{e^2 - 1} \sinh u & (e > 1) & \text{if } h > 0; \\ x &= \frac{1}{2}(p - u^2), & y &= \sqrt{p} u & & \text{if } h = 0. \end{aligned} \tag{2.3}$$

In astronomy the auxiliary variable u is called the *eccentric anomaly*, and the angle φ between the direction to the pericentre of the orbit (x -axis) and the position vector of the point, the *true anomaly*.

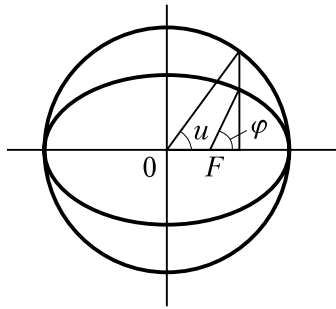

Fig. 2.4.

We have the following formulae:

$$\tan \frac{\varphi}{2} = \begin{cases} \sqrt{\frac{1+e}{1-e}} \tan \frac{u}{2} & \text{if } h < 0; \\ \sqrt{\frac{e+1}{e-1}} \tanh \frac{u}{2} & \text{if } h > 0; \\ \frac{u}{\sqrt{p}} & \text{if } h = 0. \end{cases}$$

Substituting formulae (2.3) into the area integral $x\dot{y} - y\dot{x} = c$ and integrating we obtain the following relations between time and the eccentric anomaly:

$$\begin{aligned} u - e \sin u &= n(t - t_0), & n &= \frac{\sqrt{\gamma}}{p^{3/2}} & \text{if } h < 0; \\ u - e \sinh u &= n(t - t_0), & n &= -\frac{\sqrt{\gamma}}{p^{3/2}} & \text{if } h > 0; \\ u + \frac{u^3}{3p} &= n(t - t_0), & n &= \frac{2\sqrt{\gamma}}{p} & \text{if } h = 0. \end{aligned}$$

Here t_0 is the time when the point passes the pericentre. These equations (at least the first one) are called *Kepler's equations*. The linear function $\zeta = n(t - t_0)$ is usually called the *mean anomaly*.

Thus, in the elliptic case of Kepler's problem we have to solve the transcendental Kepler's equation

$$u - e \sin u = \zeta.$$

It is clear that for $0 \leq e < 1$ this equation has an analytic solution $u(e, \zeta)$, and the difference $u(e, \zeta) - \zeta$ is periodic in the mean anomaly ζ with period 2π . There is a choice of two ways of representing the function $u(e, \zeta)$ in a form convenient for calculations:

- 1) one can expand the difference $u - \zeta$ for fixed values of e in the Fourier series in ζ with coefficients depending on e ;
- 2) one can try to represent $u(e, \zeta)$ as a series in powers of the eccentricity e with coefficients depending on ζ .

In the first case we have

$$u = \zeta + 2 \sum_{m=1}^{\infty} \frac{J_m(me)}{m} \sin m\zeta, \quad (2.4)$$

where

$$J_m(z) = \frac{1}{2\pi} \int_0^{2\pi} \cos(mx - z \sin x) dx = \sum_{k=0}^{\infty} \frac{(-1)^k (z/2)^{m+2k}}{k!(m+k)!} \quad (m = 0, 1, \dots)$$

is the *Bessel function* of order m . "These ... functions ... have been used extensively, precisely in this connection (which is that of Bessel), and more than half a century prior to Bessel, by Lagrange and others."¹

¹ See Wintner [52].

The proof of formula (2.4) is based on the simple calculation

$$\begin{aligned} \frac{du}{d\zeta} &= \frac{1}{1 - e \cos u} \\ &= \frac{1}{2\pi} \int_0^{2\pi} \frac{d\zeta}{1 - e \cos u} + \sum_{m=1}^{\infty} \frac{\cos m\zeta}{\pi} \int_0^{2\pi} \frac{\cos m\zeta d\zeta}{1 - e \cos u} \\ &= \frac{1}{2\pi} \int_0^{2\pi} du + \sum_{m=1}^{\infty} \frac{\cos m\zeta}{\pi} \int_0^{2\pi} \cos [m(u - e \sin u)] du \\ &= 1 + 2 \sum_{m=1}^{\infty} J_m(me) \cos m\zeta. \end{aligned}$$

It remains to integrate this formula with respect to ζ .

Under the second approach we have the expansion

$$u(e, \zeta) = \sum_{m=0}^{\infty} c_m(\zeta) \frac{e^m}{m!}, \tag{2.5}$$

where

$$c_m(\zeta) = \left. \frac{\partial^m u(e, \zeta)}{\partial e^m} \right|_{e=0}.$$

Using the well-known Lagrange formula for the local inversion of holomorphic functions² ([603], §7.32) we obtain the following formulae for the coefficients of this series:

$$c_0(\zeta) = \zeta; \quad c_m(\zeta) = \frac{d^{m-1}}{d\zeta^{m-1}} \sin^m \zeta, \quad m \geq 1.$$

The functions $c_m(\zeta)$ are trigonometric polynomials in the mean anomaly ζ . One can obtain the expansion (2.4) by rearranging the terms of the series (2.5). This is how Lagrange arrived at formula (2.4).

By the implicit function theorem (and in view of the periodicity of the function $u(e, \zeta) - \zeta$) the series (2.5) converges on the entire real axis $\zeta \in R$ for small e . A detailed analysis of the expansion (2.4) shows that Lagrange’s series converges for $e \leq 0.6627434 \dots$ ³

2.1.3 Collisions and Regularization

Above we were assuming that the area constant c is non-zero. Now suppose that $c = 0$. The motion of the point will be rectilinear and we can assume that

² Obtained by Lagrange precisely in connection with solving Kepler’s equation.
³ “In fact, a principal impetus for Cauchy’s discoveries in complex function theory was his desire to find a satisfactory treatment for Lagrange’s series” (Wintner [52]).

it takes place along the x -axis. If at some instant the velocity \dot{x} is directed to the centre of attraction, then $x(t) \rightarrow 0$ and $\dot{x}(t) \rightarrow \infty$ as t approaches some t_0 . Thus, the two bodies will collide at time $t = t_0$. It is clear that for $c = 0$ the function $x(t)$, $t \in \mathbb{R}$, necessarily has a singularity of this kind.

We now show that the eccentric anomaly u is a *regularizing* variable that resolves the singularity of the analytic function $x(t)$. If $c = 0$, then $e = 1$ in the elliptic and hyperbolic cases, and $p = 0$ in the parabolic case. Consequently, formulae (2.3) take the form

$$x = a(\cos u - 1), \quad x = a(\cosh u - 1), \quad x = -\frac{u^2}{2}. \quad (2.6)$$

In accordance with these formulae, for $h < 0$ the collisions take place at $u = 2\pi k$, $k \in \mathbb{Z}$; and for $h \geq 0$, only at $u = 0$. In the elliptic case it is also sufficient to consider the case $u = 0$.

We assume for simplicity that $t_0 = 0$. It is easy to obtain from Kepler's equations (for $e = 1$) that

$$t = u^3 f(u)$$

in a neighbourhood of the point $u = 0$, where f is an analytic function in a neighbourhood of zero such that $f(0) \neq 0$. From (2.6) we obtain a similar representation

$$x = u^2 g(u)$$

with an analytic function g such that $g(0) \neq 0$. Eliminating the eccentric anomaly u from these formulae we obtain Puiseux's expansion

$$x(t) = (\sqrt[3]{t})^2 \sum_{n=0}^{\infty} c_n (\sqrt[3]{t})^n.$$

The coefficients c_n with odd indices are obviously equal to zero, and $c_0 \neq 0$. Consequently, $x(t)$ is an even function of time, that is, the moving point is reflected from the centre of attraction after the collision. If x and t are regarded as complex variables, then $t = 0$ is an algebraic branching point of the analytic function $x(t)$. The three sheets of its Riemann surface meet at the collision point $t = 0$, and the real values of $x(t)$ for $t > 0$ and $t < 0$ lie only on one of the sheets. Consequently, the function $x(t)$ admits a unique real continuation.⁴

In conclusion we mention that regularization of the two-body problem in the general elliptic case (where $h < 0$) can be achieved by the transformation of coordinates $z = x + iy \mapsto w$ and time $t \mapsto \tau$ given by the formulae

$$z = w^2, \quad t' = \frac{dt}{d\tau} = 4|w^2| = 4|z|. \quad (2.7)$$

This transformation takes the motions in Kepler's problem with constant energy $h < 0$ to the motions of the harmonic oscillator $w'' + 8|h|w = 0$ on the

⁴ Regularization of collisions in the two-body problem goes back to Euler.

energy level

$$\frac{|w'|^2}{2} = 4\gamma + 4h|w^2| \tag{2.8}$$

(cf. Proposition 2.4).

The regularizing variable τ depends linearly on the eccentric anomaly u . Indeed, since

$$|z| = r = a(1 - e \cos u) \quad \text{and} \quad nt = u - e \sin u,$$

we have

$$\frac{du}{dt} = \frac{n}{1 - e \cos u} = \frac{na}{r},$$

whence $u = 4na\tau$.

2.1.4 Geometry of Kepler’s Problem

Moser observed that by using an appropriate change of the time variable one can transform the phase flow of Kepler’s problem into the geodesic flow on a surface of constant curvature. We shall follow [488] in the exposition of this result.

Lemma 2.1. *Let $x(t)$ be a solution of a Hamiltonian system with Hamiltonian $H(x)$ situated on the level $H = 0$. We change the time variable $t \mapsto \tau$ along the trajectories by the formula $d\tau/dt = G^{-1}(x) \neq 0$. Then the function $x(\tau) = x(t(\tau))$ is a solution of the Hamiltonian system (in the same symplectic structure) with the Hamiltonian $\tilde{H} = HG$. If $G = 2(H + \alpha)$, then one can take $\tilde{H} = (H + \alpha)^2$.*

We write down the Hamiltonian of Kepler’s problem in the notation of § 2.1.3: $H = |p|^2/2 - \gamma/|z|$, where $p = \dot{z}$. We change the time variable $\dot{\tau} = |z|^{-1}$ on the manifold $H = h$ (cf. (2.7)). By Lemma 2.1 this corresponds to passing to the Hamiltonian function $|z|(H - h) = |z|(|p|^2 - 2h)/2 - \gamma$. We perform another change of the time variable $\tau \mapsto ' \tau$, $d(' \tau)/d\tau = (2(|z|(H - h) + \gamma))^{-1}$ on the same level $H = h$. In the end we obtain a Hamiltonian system with the Hamiltonian function

$$\tilde{H} = |z|^2 \frac{(|p|^2 - 2h)^2}{4}.$$

Finally we perform the Legendre transformation regarding p as a coordinate, and z as the momentum. As a result we obtain a natural system with the Lagrangian

$$L = \frac{|p'|^2}{(2h - |p|^2)^2}. \tag{2.9}$$

This function defines a Riemannian metric of constant Gaussian curvature (positive for $h < 0$, and negative for $h > 0$). In the case $h < 0$ the geodesics of

the metric (2.9) (defined for all $p \in \mathbb{R}^2$) are the images of the great circles of the sphere under the stereographic projection, and in the case $h > 0$ (in which the metric is defined in the disc $|p|^2 < 2h$) the geodesics are the straight lines of the Lobachevskij plane (in Poincaré's model).

Remark 2.1 (A. B. Givental'). Let the plane (x, y) be the configuration plane of Kepler's problem with Lagrangian $L = (\dot{x}^2 + \dot{y}^2)/2 + 1/\sqrt{x^2 + y^2}$. In the space (x, y, z) we consider the right circular cone $z^2 = (x^2 + y^2)$ and the family of inscribed paraboloids of revolution $z = (x^2 + y^2)/4\alpha + \alpha$, where α is a parameter. By "projection" we shall mean the projection of the space (x, y, z) onto the plane (x, y) parallel to the z -axis. One can show that

- 1) the trajectories of Kepler's problem are the projections of the planar sections of the cone (in particular, the vertex of the cone is a focus of the projections of its planar sections),
- 2) the trajectories with the same value of the total energy are the projections of the sections of the cone by the planes tangent to one and the same paraboloid,
- 3) the trajectories with the same value of the angular momentum are the projections of the sections of the cone by the planes passing through one and the same point of the z -axis.

2.2 Collisions and Regularization

2.2.1 Necessary Condition for Stability

We now turn to the general n -body problem dealing with n material points $(m_1, \mathbf{r}_1), \dots, (m_n, \mathbf{r}_n)$ attracted to each other according to the law of universal gravitation. The kinetic energy is

$$T = \frac{1}{2} \sum m_i \dot{\mathbf{r}}_i^2$$

and the force function

$$V = \sum_{j < k} \frac{m_j m_k}{r_{jk}}, \quad r_{jk} = |\mathbf{r}_j - \mathbf{r}_k|,$$

is always positive. We introduce an inertial frame of reference with origin at the centre of mass, and let the \mathbf{r}_i be the position vectors of the points in the new frame. The equations of the n -body problem have the form of Lagrange's equations with the Lagrangian $L = T + V$.

We say that a motion $\mathbf{r}_s(t)$ ($1 \leq s \leq n$) is *stable* if the following two conditions hold:

- a) $r_{ij}(t) \neq 0$ for all values of t and all $i \neq j$ (there are no collisions);

b) $|r_{ij}(t)| \leq c$, where $c = \text{const}$.

Theorem 2.3 (Jacobi). *If a motion is stable, then the total energy $h = T - V$ is negative.*

◁ We apply Lagrange's formula

$$\ddot{I} = 2V + 4h, \tag{2.10}$$

where $I = \sum m_i r_i^2$ is the polar moment of inertia. If $h \geq 0$, then the function $I(t)$, $t \in \mathbb{R}$, is convex and therefore cannot be simultaneously bounded below and above. To complete the proof it remains to use Lagrange's identity:

$$I \sum m_i = \sum_{j < k} m_j m_k r_{jk}^2 + \left(\sum m_i \mathbf{r}_i \right)^2. \quad \triangleright$$

Under the additional assumption that the mutual distances be bounded below ($|r_{ij}(t)| \geq c > 0$) it follows from the energy integral and Lagrange's formula (2.10) that along a stable motion the mean values

$$\lim_{s \rightarrow \infty} \frac{1}{s} \int_0^s V(t) dt, \quad \lim_{s \rightarrow \infty} \frac{1}{s} \int_0^s 2T(t) dt$$

exist and are equal to $-2h > 0$.

The necessary condition for stability $h < 0$ is not sufficient if $n > 2$.

2.2.2 Simultaneous Collisions

If the position vectors $\mathbf{r}_i(t)$ of all points have one and the same limit \mathbf{r}_0 as $t \rightarrow t_0$, then we say that a simultaneous collision takes place at time t_0 . The point \mathbf{r}_0 clearly must coincide with the centre of mass, that is, $\mathbf{r}_0 = \mathbf{0}$. A simultaneous collision occurs if and only if the polar moment of inertia $I(t)$ tends to zero as $t \rightarrow t_0$.

Theorem 2.4. *If $I(t) \rightarrow 0$ as $t \rightarrow t_0$, then the constant vector of angular momentum is equal to zero:*

$$K = \sum m_i (\mathbf{r}_i \times \dot{\mathbf{r}}_i) = \mathbf{0}.$$

For $n = 3$ this theorem was already known to Weierstrass.

◁ Since $V(t) \rightarrow +\infty$ as $t \rightarrow t_0$, by the equation $\ddot{I} = 2V + 4h$ we have $\ddot{I}(t) > 0$ for the values of time close to t_0 . Consequently, $I(t)$ is monotonically decreasing before the collision.

We use the inequality $K^2 \leq 2IT$ (see §1.1), which is equivalent to the inequality

$$\ddot{I} \geq \frac{K^2}{I} + 2h$$

by Lagrange's formula. We multiply this inequality by the positive number $-2\dot{I}$ and integrate it on the interval (t_1, t) for $t < t_0$:

$$\dot{I}^2(t_1) - \dot{I}^2(t) \geq 2K^2 \ln \frac{I(t_1)}{I(t)} + 4h(I(t_1) - I(t)).$$

All the more we have the inequality

$$2K^2 \ln \frac{I(t_1)}{I(t)} \leq \dot{I}^2(t_1) + 4|h|I(t_1).$$

This implies the existence of a positive lower bound for $I(t)$ on the interval (t_1, t_0) if $K^2 \neq 0$. \triangleright

2.2.3 Binary Collisions

We say that a binary collision happens at time t_0 if the distance between two points, say, m_1 and m_n , tends to zero as $t \rightarrow t_0$, while the mutual distances between the other points are bounded below by some positive quantity for the values of t close to t_0 . For such values of t the influence of the points m_2, \dots, m_{n-1} on the motion of m_1 and m_n is clearly negligible by comparison with the interaction of m_1 and m_n . Therefore it is natural to expect that at times t close to t_0 the behaviour of the vector $\mathbf{r}_{1n}(t) = \mathbf{r}_1(t) - \mathbf{r}_n(t)$ is approximately the same as in the problem of collision of two bodies (see § 2.1). In the two-body problem a locally uniformizing variable was the true anomaly $u(t)$, which is proportional to the integral of the inverse of the distance between the points. Therefore in the case of a binary collision it is natural to try to regularize the solution by the variable

$$u(t) = \int_{t_0}^t \frac{ds}{|\mathbf{r}_{1n}(s)|}. \quad (2.11)$$

One can show that this consideration indeed achieves the goal: the functions $\mathbf{r}_k(u)$ are regular near the point $u = 0$ (corresponding to the binary collision) and in addition, $t(u) - t_0 = u^3 p(u)$, where $p(\cdot)$ is a function holomorphic near $u = 0$ and such that $p(0) \neq 0$. Thus, in the case of a binary collision, just like in the two-body problem, the coordinates of the points \mathbf{r}_k are holomorphic functions of the variable $\sqrt[3]{t - t_0}$ and therefore admit a unique real analytic continuation for $t > t_0$. One can show that the functions $\mathbf{r}_2(t), \dots, \mathbf{r}_{n-1}(t)$ are even holomorphic in a neighbourhood of the point t_0 .

To make the uniformizing variable $u(t)$ suitable for any pair of points and any instant of a binary collision one should replace (2.11) by the formula

$$u(t) = \int_0^t V(s) ds = \int_0^t \sum_{j < k} \frac{m_j m_k}{|\mathbf{r}_{jk}(s)|} ds.$$

If the polar angular momentum is non-zero, then binary collisions are the only possible singularities in the three-body problem. As shown by Sundman, the functions $\mathbf{r}_k(u)$ ($1 \leq k \leq 3$) are holomorphic in some strip $|\operatorname{Im} u| < \delta$ of the complex plane $u \in \mathbb{C}$ containing the real axis. We now map this strip conformally onto the unit disc $|\omega| < 1$ by the transformation

$$\omega = \frac{e^{\pi u/2\delta} - 1}{e^{\pi u/2\delta} + 1},$$

which takes the real axis $-\infty < u < +\infty$ to the segment $-1 < \omega < 1$. As a result the coordinates of the points \mathbf{r}_k become holomorphic functions in the disc $|\omega| < 1$ and can be represented as converging power series in the new variable ω . These series represent the motion of the three bodies for all values of time $t \in (-\infty, +\infty)$.⁵

This result is due to Sundman (1913); he followed the earlier work of Poincaré and Weierstrass, who obtained expansions of the solutions of the n -body problem in converging power series in the auxiliary variable ω in the absence of collisions. As for the possibility of collisions, they are infinitely rare in the three-body problem. Using the theorem on simultaneous collisions and the regularization of binary collisions one can show that in the twelve-dimensional state space of the three-body problem (for a fixed position of the centre of mass) the collision trajectories lie on certain singular analytic surfaces of dimension 10. Their measure is, of course, equal to zero. However, it is not known whether these singular surfaces can fill everywhere densely entire domains in the state space.

In conclusion we give as an illustration the results of numerical calculations in the “Pythagorean” variant of the three-body problem where the bodies with masses 3, 4, 5 are initially at rest in the (x, y) -plane at the points with coordinates $(1, 3)$, $(-2, -1)$, $(1, -1)$. The centre of mass of this system is at the origin.

The calculations of the Pythagorean three-body problem were started by Burrau back in 1913 and were continued in modern times by Szebehely using computers. In Fig. 2.5–2.7 one can see close encounters of the points, their binary collisions, and the dispersal of the triple system. Fig. 2.8 shows a “final” motion: the point of mass $m = 5$ is moving away along a straight line from the “double star” formed by the points $m = 3$ and $m = 4$, which periodically collide with each other. It is interesting that no triple collisions occur, although the angular momentum is equal to zero in this case.

⁵ The power series in ω are absolutely useless for practical computations because of their extremely slow rate of convergence.

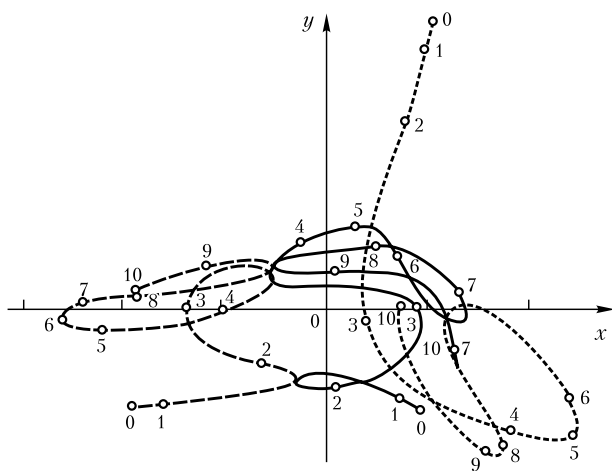

Fig. 2.5. Motion of gravitating masses in the Pythagorean three-body problem in the time interval from $t = 0$ to $t = 10$

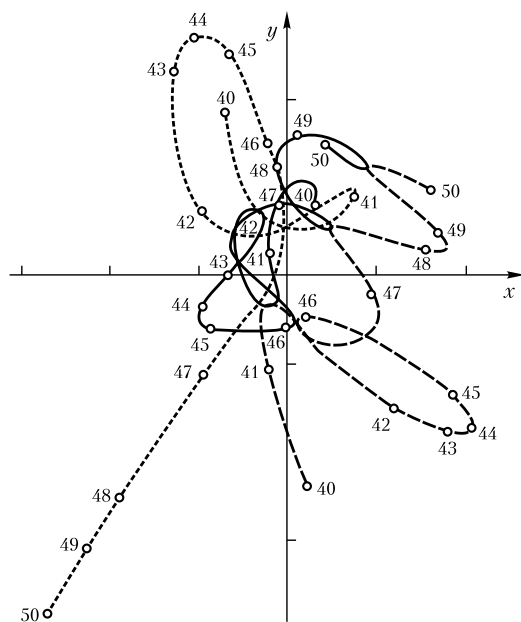

Fig. 2.6. Form of the orbits in the Pythagorean three-body problem in the time interval from $t = 40$ to $t = 50$

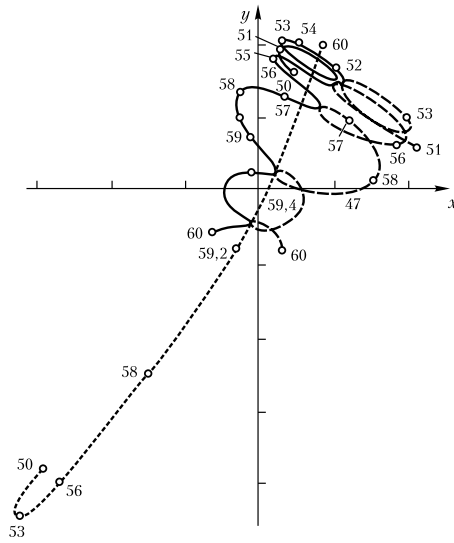

Fig. 2.7. Evolution of the orbits of the Pythagorean three-body problem in the time interval from $t = 50$ to $t = 60$

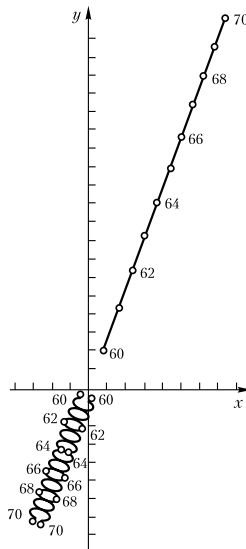

Fig. 2.8. Formation of a double star in the Pythagorean three-body problem (from $t = 60$ to $t = 70$)

2.2.4 Singularities of Solutions of the n -Body Problem

In the case of multiple collisions, when simultaneous collisions of $k \geq 3$ points occur, the singular points of the coordinates \mathbf{r}_s of gravitating points as functions of time have a much more complicated structure from the analytic viewpoint. Generally speaking, these singularities are not algebraic; moreover, the functions $\mathbf{r}_s(t)$ ($1 \leq s \leq n$) have no real analytic continuation after the instant of collision.

This can be seen even in examples of simultaneous collision in the three-body problem. It turns out that for arbitrary values of the masses m_1, m_2, m_3 there exist solutions of the form

$$\mathbf{r}_i(t) = t^{2/3} \sum_{m=0}^{\infty} \mathbf{a}_{im} t^{\alpha m}. \quad (2.12)$$

The positive number α is a non-constant algebraic function of the masses m_1, m_2, m_3 , and the coefficients \mathbf{a}_{i1} are not all equal to zero. At time $t = 0$ a triple collision took place. In a typical case where α is irrational, the series (2.12) has an isolated logarithmic singular point at $t = 0$. In particular, this solution, which is real for $t > 0$, has infinitely many different analytic branches for $t < 0$, but all these branches turn out to be complex.

Solution (2.12) was found by Block (1909) and Chazy (1918) using the following method. For any values of the masses the equations of the three-body problem admit a “homographic” solution such that the triangle formed by the bodies always remains similar to itself. This solution is analytically represented by the formula

$$\mathbf{r}_i(t) = \mathbf{a}_{i0} t^{2/3} \quad (1 \leq i \leq 3). \quad (2.13)$$

Among the characteristic roots of the variational equation for this solution there is a negative number ($-\alpha$). According to the well-known results of Lyapunov and Poincaré the equations of motion have a solution (2.12) that is asymptotic to solution (2.13). We remark that the method of Block and Chazy had already been applied by Lyapunov (1894) for proving that the solutions of the equations of rotation of a heavy rigid body with a fixed point are not single-valued as functions of complex time.

Consider a particular solution $\mathbf{r}_k(t)$ of the three-body problem. Suppose that at the initial time t_0 we have $r_{jk} \neq 0$ for all $j \neq k$. We trace this solution for $t > t_0$. There are three possibilities:

- (a) there are no collisions for any $t > t_0$; then this motion proceeds without singularities up to $t = +\infty$;
- (b) at some instant $t_1 > t_0$ a collision occurs that admits an analytic continuation;
- (c) at some instant a collision occurs that does not admit an analytic continuation.

Suppose that case (b) takes place. Then for $t > t_1$ again one of the variants (a)–(c) is possible. Continuing this process we can either arrive after finitely many steps at one of the cases (a), (c), or have infinitely many continuable collisions occurring at times $t_1, t_2, \dots, t_k, \dots$. One can show that for $n = 3$ in the latter case we have

$$\lim_{k \rightarrow \infty} t_k = +\infty.$$

However, in the n -body problem for $n \geq 4$ a fundamentally different type of singularities is possible. Even in the four-body problem on a straight line there exist motions such that infinitely many binary collisions occur over a finite time interval $[0, t_*)$. Moreover, in the end, as $t \rightarrow t_*$ three of the bodies move away to infinity: one in one direction, and two others in the opposite direction, as in the Pythagorean three-body problem. But unlike the case of three bodies, the colliding bodies approach each other arbitrarily closely, which is what gives the energy for going to infinity over a finite time. The fourth body oscillates between the bodies going to infinity in opposite directions. When the oscillating body approaches closely the cluster of two bodies, an almost triple collision occurs. The existence of such a motion was proved by Mather using McGehee's regularization of simultaneous collisions in the three-body problem (see [419]).

In the spatial five-body problem there are collision-free singularities: over a finite time the bodies move away to infinity without ever having collisions [531, 607]. The existence of collision-free singularities was also proved for the planar $3N$ -body problem for sufficiently large N ; see [255].

2.3 Particular Solutions

Only a few exact solutions have been found in the n -body problem. For the case of bodies of different masses practically all of these solutions had already been known to Euler and Lagrange.

2.3.1 Central Configurations

We say that n material points (m_i, \mathbf{r}_i) form a *central configuration* in a barycentric frame of reference if

$$\frac{\partial V}{\partial \mathbf{r}_i} = \sigma \frac{\partial I}{\partial \mathbf{r}_i}, \quad 1 \leq i \leq n, \quad (2.14)$$

where

$$V = \sum_{k < j} \frac{m_k m_j}{r_{kj}}$$

is the potential of gravitational interaction, $I = \sum m_i r_i^2$ is the polar moment of inertia, and σ is a scalar function independent of the index i . It follows

from Euler's formula for homogeneous functions that $\sigma = -V/2I$. Thus, formula (2.14) can also be written in the form

$$I \frac{\partial V}{\partial \mathbf{r}_i} = -\frac{1}{2} V \frac{\partial I}{\partial \mathbf{r}_i}.$$

Consequently, central configurations correspond to the critical points of the function IV^2 . Since this function is homogeneous, the set (m_i, \mathbf{r}_i) is a central configuration simultaneously with the set $(m_i, \alpha \mathbf{r}_i)$ for any $\alpha \neq 0$. We shall not distinguish between such configurations.

Finding all central configurations for any number of points n is a complicated algebraic problem, which is still unsolved. Leaving aside the trivial case $n = 2$, we list the known results in this area.

For $n = 3$ the only non-collinear central configuration is the equilateral triangle (Lagrange). For $n = 4$ the only non-coplanar configuration is the regular tetrahedron.

If the masses of all bodies are equal, then for $n = 4$ the only planar central configurations are those in which the bodies are situated either on one straight line, or in the vertices of a square, or in the vertices and in the centre of an equilateral triangle, or in the vertices and on the symmetry axis of an isosceles triangle [62, 63].

The collinear central configurations are described by the following *Moulton's theorem* [52]: corresponding to every numbering of the point masses there is a unique central configuration in which the points are situated on one straight line in the given order. Thus, there exist exactly $n!/2$ different collinear central configurations. For $n = 3$ there are exactly three such configurations; they were discovered by Euler.

There is a conjecture that for a given n and given masses the number of central configurations is finite [166] and, moreover, is bounded by a constant independent of the masses [52]. These problems are open also for the planar case [559]. (A planar central configuration is a relative equilibrium configuration of the n -body problem; see §2.3.3.) For $n = 4$ in the planar case the conjecture of [166, 52] was proved in [274]; the case $n = 5$ remains open.

The concept of a central configuration is useful in the analysis of simultaneous collisions: it turns out that the configuration of gravitating points at the instant of a simultaneous collision is central (in the asymptotic sense). It follows from (2.14) that if initially the points formed a central configuration and were at rest, then their configuration clearly does not change up to the instant of a simultaneous collision.

2.3.2 Homographic Solutions

We say that a solution of the n -body problem is *homographic* if in a barycentric reference frame the configurations formed by the bodies remain similar to each other at all times. If in addition the configuration is not rotating,

then such a solution is said to be *homothetic*. The solutions mentioned at the end of the preceding subsection may serve as an example. If the configuration remains congruent to itself, then the solution is called a *relative equilibrium*.

It is easy to show that

- a) a homographic solution is homothetic if and only if the polar angular momentum is equal to zero;
- b) a homographic solution is a relative equilibrium if and only if it is planar and its configuration rotates with constant angular velocity.

The proof of the following facts is more difficult:

- c) if a homographic solution is non-coplanar, then it is homothetic;
- d) if a homographic solution is coplanar, then it is planar.

In particular, every homographic solution is either planar or homothetic. In the three-body problem all the homographic solutions have the property that in a barycentric reference frame the three bodies lie in an invariable plane containing the centre of mass (Lagrange).

Proposition 2.5. *If a solution is homographic, then the bodies form a central configuration at all times.*

This proposition provides a method for constructing homographic solutions. We give as an example the well-known *Lagrange's theorem* (1772).

Theorem 2.5. *For arbitrary values of the masses, the three-body problem admits an exact solution such that*

- 1) *the plane containing these points is invariant in a barycentric reference frame,*
- 2) *the resultant of the two Newtonian gravitational forces applied to each of the three material points passes through their common centre of mass,*
- 3) *the triangle formed by the three bodies is equilateral,*
- 4) *the trajectories of the three bodies are conic sections similar to each other with a focus at the common centre of mass.*

In the special case of equal masses the conic sections are congruent and differ from one another by a rotation through 120° . This remark can be generalized: the problem of n points of equal masses has a solution in which each body is describing a conic section with a focus at the centre of mass, the trajectories are congruent and differ from one another by a rotation through $2\pi/n$.

2.3.3 Effective Potential and Relative Equilibria

Proposition 2.6. *The configurations of relative equilibria with polar angular momentum K coincide with the critical points of the function*

$$U_K = U + \frac{K^2}{2I}, \quad \text{where } U = -V.$$

The function U_K is called the *effective* (or *amended*, or *reduced*) *potential*. We used it § 1.1 for describing the regions of possible motion in the planar n -body problem, and in § 2.1 for finding the trajectories of two bodies.

◁ Suppose that the configuration of a relative equilibrium is rotating around the centre of mass with constant angular velocity ω . Then, clearly, $K = I\omega$. We pass to a reference frame with coordinates u, v rotating with the angular velocity ω ; in this frame the configuration of the relative equilibrium is stationary. In the new frame the Lagrangian function is

$$L = T + V = \frac{1}{2} \sum m_i (\dot{u}_i^2 + \dot{v}_i^2) + \omega \sum m_i (u_i \dot{v}_i - \dot{u}_i v_i) + V_\omega,$$

where $V_\omega = V + I\omega^2/2$. The equations of motion are

$$m_i \ddot{u}_i = 2m_i \omega \dot{v}_i + \frac{\partial V_\omega}{\partial u_i}, \quad m_i \ddot{v}_i = -2m_i \omega \dot{u}_i + \frac{\partial V_\omega}{\partial v_i}. \quad (2.15)$$

One can easily derive Proposition 2.6 from these equations using the following observation: the functions U_K and V_ω have the same critical points, since $K = I\omega$ at these points. ▷

2.3.4 Periodic Solutions in the Case of Bodies of Equal Masses

If all the n bodies have the same mass, then one can seek periodic solutions in which all the bodies move along the same trajectory lagging one behind another by equal time intervals. The law of motion of the j th body ($j = 1, \dots, n$) is sought in the form

$$\mathbf{r}_j(t) = \mathbf{r}(t - (j-1)T/n), \quad (2.16)$$

where $\mathbf{r}(\cdot)$ is a periodic function with period T . Such solutions are called *simple choreographies* (this term was suggested by Simó). The function $\mathbf{r}(\cdot)$ can be determined from the condition that a periodic solution is an extremal of the action functional (see § 1.2.3).

For the three-body problem ($n = 3$) a solution of the form (2.16) was first found numerically [431]. Then an analytic proof of its existence was given [170]. In this solution the three bodies describe one and the same planar curve having the shape of 8 with equal loops. Over the period T each body passes twice the self-intersection point of the trajectory, and at these instants

all the three bodies are situated on one straight line and form a collinear central configuration (cf. §2.3.1; one of the bodies bisects the segment between the other two bodies). This periodic solution is stable in the linear approximation. Furthermore, the nonlinear terms in the expansion of the Hamiltonian of the problem about this periodic solution are such that KAM theory (§6.3) guarantees “stability with respect to the measure of initial data”: a small neighbourhood of this periodic motion is foliated, up to a remainder of small relative measure, into the invariant tori, on which the motion is conditionally periodic [551, 553].

In the case $n > 3$ solutions of the form (2.16) have so far been found only numerically; all these solutions proved to be unstable. The existence of such solutions is at present established analytically for the interaction potential $U = -\gamma/r_{ij}^a$, $a \geq 2$ (the Newtonian potential corresponds to $a = 1$) [551, 552].

The variational approach was also used in the search for periodic solutions in which the orbits of all bodies are congruent curves permuted by a symmetry. Such a periodic solution was found in the four-body problem [171]. Over the period of the motion the bodies form a central configuration four times: twice they are situated in the vertices of a square, and twice in the vertices of a tetrahedron.

2.4 Final Motions in the Three-Body Problem

2.4.1 Classification of the Final Motions According to Chazy

Here, dealing with the three-body problem, we shall denote by \mathbf{r}_k the vector from the point mass m_i to the point mass m_j for $i \neq k$, $j \neq k$, $i < j$.

Theorem 2.6 (Chazy, 1922). *Every solution of the three-body problem $\mathbf{r}_k(t)$ ($k = 1, 2, 3$) belongs to one of the following seven classes:*

- 1°. H (hyperbolic motions): $|\mathbf{r}_k| \rightarrow \infty$, $|\dot{\mathbf{r}}_k| \rightarrow c_k > 0$ as $t \rightarrow +\infty$;
- 2°. HP_k (hyperbolic-parabolic): $|\mathbf{r}_i| \rightarrow \infty$, $|\dot{\mathbf{r}}_k| \rightarrow 0$, $|\dot{\mathbf{r}}_i| \rightarrow c_i > 0$ ($i \neq k$);
- 3°. HE_k (hyperbolic-elliptic): $|\mathbf{r}_i| \rightarrow \infty$, $|\dot{\mathbf{r}}_i| \rightarrow c_i > 0$ ($i \neq k$), $\sup_{t \geq t_0} |\mathbf{r}_k| < \infty$;
- 4°. PE_k (parabolic-elliptic): $|\mathbf{r}_i| \rightarrow \infty$, $|\dot{\mathbf{r}}_i| \rightarrow 0$ ($i \neq k$), $\sup_{t \geq t_0} |\mathbf{r}_k| < \infty$;
- 5°. P (parabolic): $|\mathbf{r}_i| \rightarrow \infty$, $|\dot{\mathbf{r}}_i| \rightarrow 0$;
- 6°. B (bounded): $\sup_{t \geq t_0} |\mathbf{r}_k| < \infty$;
- 7°. OS (oscillating): $\overline{\lim}_{t \rightarrow +\infty} \sup_k |\mathbf{r}_k| = \infty$, $\underline{\lim}_{t \rightarrow +\infty} \sup_k |\mathbf{r}_k| < \infty$.

Examples of motions of the first six types were known to Chazy. The existence of oscillating motions was proved by Sitnikov in 1959.

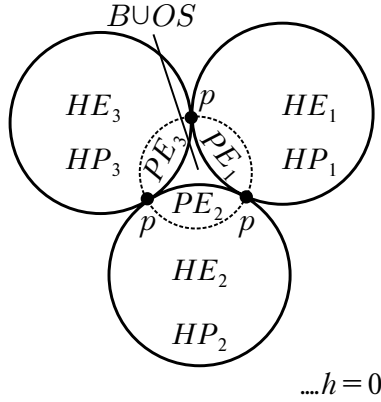

Fig. 2.9.

It is natural to associate with the seven types of final motions listed above the subsets of the twelve-dimensional phase space of the three-body problem M^{12} with a fixed position of the centre of mass: these subsets are composed entirely of the phase trajectories corresponding to the motions of a given type. The qualitative picture of the partition of M^{12} into the classes of final motions is represented by Fig. 2.9. The sets H and HP_k are entirely contained in the domain where the constant of total energy h is positive; P lies on the hypersurface $h = 0$; the sets B, PE_k, OS , in the domain $h < 0$; and motions in the class HE_k are possible for any value of h . It is known that H and HE_k are open in M^{12} , HP_k consists of analytic manifolds of codimension 1, and P consists of three connected manifolds of codimension 2 (represented by the three points in Fig. 2.9) and one manifold of codimension 3 (which is not shown in Fig. 2.9). The topology of the other classes has not been studied sufficiently.

2.4.2 Symmetry of the Past and Future

By Chazy's theorem one can introduce seven analogous final classes of motions when t tends not to $+\infty$, but to $-\infty$. To distinguish the classes in the cases $t \rightarrow \pm\infty$ we shall use the superscripts (+) and (-): H^+, HE_3^- , and so on. In one of Chazy's papers (1929) a false assertion was stated that in the three-body problem the two final types, for $t \rightarrow \infty$ and $t \rightarrow -\infty$, of the same solution coincide. The misconception of the "symmetry" of the past and future had been holding ground for a fairly long time, despite the numerical counterexample constructed by Bekker (1920), which asserted the possibility of "exchange": $HE_1^- \cap HE_2^+ \neq \emptyset$. Bekker's example had been "explained" by errors in numerical integration. In 1947 Shmidt produced an example of "capture" in the three-body problem: $H^- \cap HE^+ \neq \emptyset$. This example, which was also constructed by a numerical calculation, was given by Shmidt in support of his well-known cosmogony hypothesis. A rigorous proof of the possibility of capture was found by Sitnikov in 1953.

The current state of the problem of final motions in the three-body problem is concisely presented in Tables 2.1 and 2.2, which we borrowed from Alekseev’s paper [3]. Each cell corresponds to one of the logically possible combinations of the final types in the past and future. The Lebesgue measure of the corresponding sets in M^{12} is indicated (where it is known).

Table 2.1.

$h > 0$		$t \rightarrow +\infty$	
		H^+	HE_i^+
t \downarrow $-\infty$	H^-	Lagrange, 1772 (isolated examples); Chazy, 1922 Measure > 0	PARTIAL CAPTURE Measure > 0 Shmidt (numerical example), 1947; Sitnikov (qualitative methods), 1953
	HE_j^-	COMPLETE DISPERSAL Measure > 0	$i = j$ Measure > 0 Birkhoff, 1927
$i \neq j$ EXCHANGE, Measure > 0 Bekker (numerical examples), 1920; Alekseev (qualitative methods), 1956			

Table 2.2.

$h < 0$		$t \rightarrow +\infty$		
		HE_i^+	B^+	OS^+
t \downarrow $-\infty$	HE_j^-	$i = j$ Measure > 0 Birkhoff, 1927	COMPLETE CAPTURE $\left\{ \begin{array}{l} \text{Measure} = 0 \\ \text{Chazy, 1929 and} \\ \text{Merman, 1954;} \\ \text{Littlewood, 1952;} \\ \text{Alekseev, 1968,} \\ \neq \emptyset \end{array} \right.$	$\left\{ \begin{array}{l} \text{Measure} = 0 \\ \text{Chazy, 1929 and} \\ \text{Merman, 1954;} \\ \text{Alekseev, 1968,} \\ \neq \emptyset \end{array} \right.$
		EXCHANGE $i \neq j$ Measure > 0 Bekker, 1920 (numerical examples); Alekseev, 1956 (qualitative methods)		
	B^-	PARTIAL DISPERSAL $\neq \emptyset$ Measure $= 0$	Euler, 1772 Lagrange, 1772, Poincaré, 1892 (isolated examples); Measure > 0 Arnold, 1963	Littlewood, 1952 Measure $= 0$ Alekseev, 1968, $\neq \emptyset$
OS^-	$\neq \emptyset$ Measure $= 0$	$\neq \emptyset$ Measure $= 0$	Sitnikov, 1959, $\neq \emptyset$ Measure $= ?$	

2.5 Restricted Three-Body Problem

2.5.1 Equations of Motion. The Jacobi Integral

Suppose that the Sun S and Jupiter J are revolving around the common centre of mass in circular orbits (see Fig. 2.10). We choose the units of length, time, and mass so that the magnitude of the angular velocity of the rotation, the sum of masses of S and J , and the gravitational constant are equal to one. It is easy to show that then the distance between S and J is also equal to one.

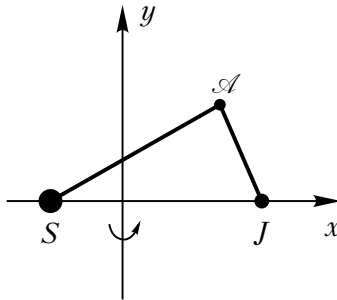

Fig. 2.10. Restricted three-body problem

Consider the motion of an asteroid \mathcal{A} in the plane of the orbits of S and J . We assume that the mass of the asteroid is much smaller than the masses of the Sun and Jupiter and neglect the influence of the asteroid on the motion of the large bodies.

It is convenient to pass to a moving frame of reference rotating with unit angular velocity around the centre of mass of S and J ; the bodies S and J are at rest in this frame. In the moving frame we introduce Cartesian coordinates x, y so that the points S and J are situated invariably on the x -axis and their centre of mass coincides with the origin. The equations of motion of the asteroid take the following form (see (2.15)):

$$\ddot{x} = 2\dot{y} + \frac{\partial V}{\partial x}, \quad \ddot{y} = -2\dot{x} + \frac{\partial V}{\partial y}; \quad V = \frac{x^2 + y^2}{2} + \frac{1 - \mu}{\rho_1} + \frac{\mu}{\rho_2}, \quad (2.17)$$

where μ is Jupiter's mass and ρ_1, ρ_2 are the distances from the asteroid \mathcal{A} to S and J . Since the coordinates of S and J are $(-\mu, 0)$ and $(1 - \mu, 0)$, we have

$$\rho_1^2 = (x + \mu)^2 + y^2, \quad \rho_2^2 = (x - 1 + \mu)^2 + y^2.$$

Equations (2.17) have the integral

$$\frac{\dot{x}^2 + \dot{y}^2}{2} - V(x, y) = h,$$

called the *Jacobi integral*, which expresses the conservation of energy in the relative motion of the asteroid.

For a fixed value of h the motion of the asteroid takes place in the domain

$$\{(x, y) \in \mathbb{R}^2: V(x, y) + h \geq 0\},$$

which is called a *Hill region*.

2.5.2 Relative Equilibria and Hill Regions

The form of Hill regions depends on the positions of the critical points of the function $V(x, y)$. Corresponding to each critical point (x_0, y_0) there is an “equilibrium” solution $x(t) \equiv x_0$, $y(t) \equiv y_0$, which can naturally be called a relative equilibrium. We claim that for every value of $\mu \in (0, 1)$ there are exactly five such points.

We calculate

$$V'_y = yf, \quad f = 1 - \frac{1 - \mu}{\rho_1^3} - \frac{\mu}{\rho_2^3},$$

$$V'_x = xf - \mu(1 - \mu) \left(\frac{1}{\rho_1^3} - \frac{1}{\rho_2^3} \right)$$

and solve the system of algebraic equations $V'_x = V'_y = 0$. First suppose that $y \neq 0$. Then $f = 0$ and therefore, $\rho_1 = \rho_2 = \rho$. From the equation $f = 0$ we obtain that $\rho = 1$. Thus, in this case the points S , J , and \mathcal{A} are in the vertices of an equilateral triangle. There are exactly two such relative equilibria, which are called *triangular* (or *equilateral*) *libration points*. They should be viewed as a special case of Lagrange’s solutions of the general “unrestricted” three-body problem (see § 2.3). Lagrange himself regarded these solutions as a “pure curiosity” and considered them to be useless for astronomy. But in 1907 an asteroid was discovered, named Achilles, which moves practically along Jupiter’s orbit being always ahead of it by 60° . Near Achilles there are 9 more asteroids (the “Greeks”), and on the other side there were discovered five asteroids (the “Trojans”), which also form an equilateral triangle with the Sun and Jupiter.

Now consider the relative equilibria on the x -axis. They are the critical points of the function

$$g(x) = \frac{x^2}{2} + \frac{1 - \mu}{|x + \mu|} + \frac{\mu}{|x - 1 + \mu|}.$$

Since $g(x) > 0$ and $g(x) \rightarrow +\infty$ as $x \rightarrow \pm\infty$, $x \rightarrow -\mu$, or $x \rightarrow 1 - \mu$, there exist three local minima of the function g in the intervals $(-\infty, -\mu)$, $(-\mu, 1 - \mu)$, $(1 - \mu, +\infty)$, into which the points S and J divide the x -axis. In view of the inequality $g''(x) > 0$ these points are the only critical points of the function g . These *collinear libration points* were found by Euler.

One can show that the collinear libration points (we denote them by L_1, L_2, L_3)⁶ are of hyperbolic type, and the triangular libration points (L_4 and L_5) are points of non-degenerate minimum of the function V . Fig. 2.11 depicts the transformation of the Hill regions as the Jacobi constant h changes from $-\infty$ to $+\infty$, under the assumption that Jupiter's mass is smaller than the Sun's mass (the complement of the Hill region is shaded).

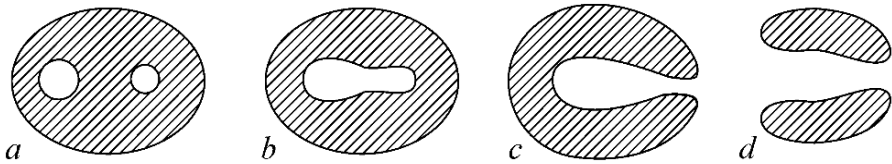

Fig. 2.11.

If h is greater than the negative number

$$-\frac{1}{2}(3 - \mu + \mu^2),$$

then the Hill region coincides with the entire plane $\mathbb{R}^2 = \{x, y\}$. For $\mu = 1/2$ the Hill regions are symmetric not only with respect to the x -axis, but also with respect to the y -axis.

The collinear libration points are always unstable: among the roots of the characteristic equation of the variational equations there are two real roots of different signs; two other roots are purely imaginary complex conjugates.⁷ For the triangular libration points the roots of the characteristic equation are purely imaginary and are distinct only when

$$27\mu(1 - \mu) < 1. \quad (2.18)$$

Under this condition the triangular relative equilibrium points are stable in the first approximation. The problem of their Lyapunov stability proved to be much more difficult; we postpone the discussion of this problem until Ch. 6. In conclusion we remark that condition (2.18) is known to be certainly satisfied for the real system Sun–Jupiter.

2.5.3 Hill's Problem

Let us choose the origin of the rotating frame of reference at the point where the body of mass μ is situated. Then the coordinates x, y of the third body

⁶ Here L_1 is between the Sun and Jupiter, L_2 beyond Jupiter, and L_3 beyond the Sun.

⁷ Two more purely imaginary complex conjugates are added to these roots in the spatial restricted three-body problem, where motions of the asteroid across the plane of the orbits of the Sun and Jupiter are also considered.

of small mass must be changed to $x - (1 - \mu)$, y . Renaming these variables again by x, y we see that the equations of motion have the same form (2.10), only the potential should be replaced by the function

$$V = (1 - \mu)x + \frac{1}{2}(x^2 + y^2) + (1 - \mu)(1 + 2x + x^2 + y^2)^{-1/2} + \mu(x^2 + y^2)^{-1/2}. \quad (2.19)$$

We now make another simplification of the problem, which was introduced by Hill and is taken from astronomy. Let the body of mass $1 - \mu$ again denote the Sun, μ the Earth, and suppose that the third body of negligible mass – the Moon – moves near the point $(0, 0)$, where the Earth is invariably situated. We neglect in (2.17) all the terms of order at least two in x, y . This is equivalent to discarding in (2.19) the terms of order at least three in x, y . With the required accuracy, V is replaced by the function

$$V = \frac{\mu}{2}(x^2 + y^2) + \frac{3}{2}(1 - \mu)x^2 + \mu(x^2 + y^2)^{-1/2}.$$

Since the mass of the Earth μ is much smaller than the mass of the Sun $1 - \mu$, we can neglect the first summand in this formula.

It is convenient to change the units of length and mass by making the substitutions

$$x \rightarrow \alpha x, \quad y \rightarrow \alpha y, \quad \mu \rightarrow \beta \mu, \quad 1 - \mu \rightarrow \beta(1 - \mu),$$

where

$$\alpha = \left(\frac{\mu}{1 - \mu} \right)^{1/3}, \quad \beta = (1 - \mu)^{-1}.$$

After this transformation the equations of motion of the Moon take the form

$$\ddot{x} - 2\dot{y} = \frac{\partial V}{\partial x}, \quad \ddot{y} + 2\dot{x} = \frac{\partial V}{\partial y}; \quad V = \frac{3}{2}x^2 + (x^2 + y^2)^{-1/2}. \quad (2.20)$$

These equations have a first integral – the Jacobi integral

$$\frac{\dot{x}^2 + \dot{y}^2}{2} - V(x, y) = h.$$

It is easy to see that on passing from the restricted three-body problem to its limiting variant called *Hill's problem* the two triangular and one collinear libration points disappear. Indeed, the system of equations $V'_x = V'_y = 0$ has only two solutions $(x, y) = (\pm 3^{-1/3}, 0)$. The Hill regions

$$\{V(x, y) + h \geq 0\}$$

are symmetric with respect to the x - and y -axes for all values of h . If $h \geq 0$, then the Hill region coincides with the entire plane. For $h < 0$ the boundary

has asymptotes parallel to the y -axis: $x = \pm(-\frac{2}{3}h)^{1/2}$. The form of the Hill regions depends on whether the constant $(-h)$ is greater than, equal to, or less than the unique critical value of the function V , which is equal to $\frac{3}{2} 3^{1/3}$. These three cases are shown in Fig. 2.12 (the Hill regions are shaded). Only case (a) is of interest for astronomical applications and, moreover, only the domain around the origin.

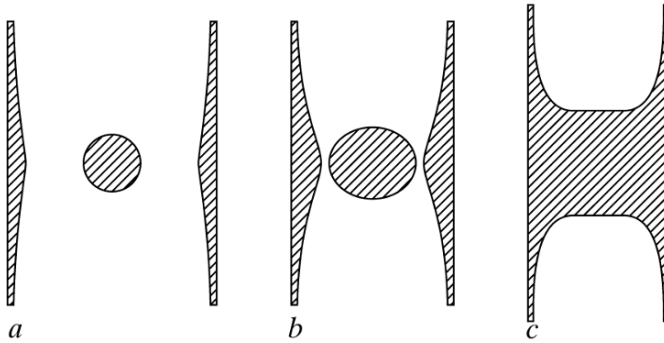

Fig. 2.12.

We now consider the questions related to regularization of Hill's problem. For that we pass to the new parabolic coordinates by the formulae $x = \xi^2 - \eta^2$, $y = 2\xi\eta$ and change the time variable $t \mapsto \tau$ along the trajectories:

$$\frac{dt}{d\tau} = 4(\xi^2 + \eta^2).$$

Denoting differentiation with respect to τ by prime we write down the equations of motion in the new variables:

$$\xi'' - 8(\xi^2 + \eta^2)\eta' = \widehat{V}'_{\xi}, \quad \eta'' + 8(\xi^2 + \eta^2)\xi' = \widehat{V}'_{\eta},$$

where

$$\widehat{V} = 4 + 4(\xi^2 + \eta^2)h + 6(\xi^2 - \eta^2)(\xi^2 + \eta^2).$$

The energy integral takes the form

$$\frac{\xi'^2 + \eta'^2}{2} - \widehat{V}(\xi, \eta, h) = 0.$$

This regularization of Hill's problem suggested by Birkhoff allows one to easily investigate the analytic singularities of solutions corresponding to collisions of the Moon with the Earth. Suppose that a collision occurs at time $t = 0$ and let $\tau(0) = 0$. Then obviously,

$$\xi = (\sqrt{8} \sin \alpha)\tau + \dots, \quad \eta = (\sqrt{8} \cos \alpha)\tau + \dots; \quad t = \frac{32}{3}\tau^3 + \dots,$$

where α is an integration constant. Thus, the new time τ is a uniformizing variable and, as in the case of binary collisions in the general three-body problem, the solution $\xi(t), \eta(t)$ admits a unique real analytic continuation after the collision.

As already mentioned, only the motions that take place near the point $\xi = \eta = 0$ are of interest for astronomy. For large negative values of h it is convenient to pass to the new variables

$$\varphi = 2\xi[-2h - 3(\xi^2 - \eta^2)^2]^{1/2}, \quad \psi = 2\eta[-2h - 3(\xi^2 - \eta^2)^2]^{1/2}.$$

After this change of variables the energy integral takes quite a simple form

$$\xi'^2 + \eta'^2 + \varphi^2 + \psi^2 = 8.$$

This is the equation of a three-dimensional sphere in the four-dimensional phase space of the variables $\xi', \eta', \varphi, \psi$. Since points (ξ, η) and $(-\xi, -\eta)$ correspond to the same point in the (x, y) -plane, the Moon's states $(\xi', \eta', \varphi, \psi)$ and $(-\xi', -\eta', -\varphi, -\psi)$ should be identified. As a result we have obtained that for large negative h the connected component of the three-dimensional energy level that we are interested in is diffeomorphic to the three-dimensional projective space. This remark is of course valid for all $h < -\frac{3}{2}\sqrt[3]{3}$.

In conclusion we discuss periodic solutions of Hill's problem, which have important astronomical applications. The question is about the periodic solutions $x(t), y(t)$ close to the Earth (the point $x = y = 0$) with a small period ϑ whose orbits are symmetric with respect to the x - and y -axes. More precisely, the symmetry conditions are defined by the equalities

$$x(-t) = x(t) = -x\left(t + \frac{\vartheta}{2}\right), \quad y(-t) = -y(t) = y\left(t + \frac{\vartheta}{2}\right).$$

Consequently, these solutions should be sought in the form of the trigonometric series

$$x(t) = \sum_{n=-\infty}^{\infty} a_n(m) \cos(2n+1)\frac{t}{m}, \quad y(t) = \sum_{n=-\infty}^{\infty} a_n(m) \sin(2n+1)\frac{t}{m},$$

where

$$m = \frac{\vartheta}{2\pi}.$$

Substituting these series into the equations of motion (2.20) we obtain an infinite nonlinear system of algebraic equations with respect to infinitely many unknown coefficients. Hill (1878) showed that this system has a unique solution, at least for small values of m (see [46, 52]). The value $m_0 = 0.08084\dots$ for the real Moon lies in this admissible interval. The convergence of Hill's series was proved by Lyapunov in 1895.

One can show that the following asymptotic expansions hold for the coefficients $a_k(m)$:

$$a_0 = m^{2/3} \left(1 - \frac{2}{3}m + \frac{7}{18}m^2 - \dots \right),$$

$$\frac{a_1}{a_0} = \frac{3}{16}m^2 + \frac{1}{2}m^3 + \dots, \quad \frac{a_{-1}}{a_0} = -\frac{19}{16}m^2 - \frac{5}{3}m^3 - \dots,$$

$$\frac{a_2}{a_0} = \frac{25}{256}m^4 + \dots, \quad \frac{a_{-2}}{a_0} = 0 \cdot m^4 + \dots, \quad \dots$$

This shows that for small values of m the main contribution to Hill's periodic solutions is given by the terms

$$x_0(t) = m^{2/3} \cos \frac{t}{m}, \quad y_0(t) = m^{2/3} \sin \frac{t}{m},$$

which represent the law of motion of the Moon around the Earth without taking into account the influence of the Sun. The presence of the coefficient $m^{2/3}$ is a consequence of Kepler's third law. For small values of the parameter m , the Sun, perturbing the system Earth–Moon, does not destroy the periodic circular motions of the two-body problem, but merely slightly deforms them.

2.6 Ergodic Theorems of Celestial Mechanics

2.6.1 Stability in the Sense of Poisson

Let (M, S, μ) be a complete space with measure; here S is the σ -algebra of subsets of M , and μ a countably additive measure on S . Let g be a measure-preserving automorphism of the set M . We call the set

$$\Gamma_p = \bigcup_{n \in \mathbb{Z}} g^n(p), \quad g^0(p) = p$$

the trajectory of a point $p \in M$, and

$$\Gamma_p^+ = \bigcup_{n \geq 0} g^n(p)$$

its positive semitrajectory.

Poincaré's Recurrence Theorem. *Suppose that $\mu(M) < \infty$. Then for any measurable set $V \in S$ of positive measure there exists a set $W \subset V$ such that $\mu(W) = \mu(V)$ and for every $p \in W$ the intersection $\Gamma_p^+ \cap W$ consists of infinitely many points.*

Following Poincaré we apply this result to the restricted three-body problem. In the notation of the preceding section the equations of motion of the asteroid have the form of Lagrange's equations with the Lagrangian

$$L = \frac{1}{2}(\dot{x}^2 + \dot{y}^2) + x\dot{y} - y\dot{x} + V, \quad V = \frac{x^2 + y^2}{2} + \frac{1 - \mu}{\rho_1} + \frac{\mu}{\rho_2}.$$

These equations can be represented in the Hamiltonian form with the Hamiltonian

$$H = \frac{1}{2}(X^2 + Y^2) + yX - xY - G, \quad G = \frac{\mu}{\rho_1} + \frac{1 - \mu}{\rho_2},$$

where $X = \dot{x} - y$, $Y = \dot{y} + x$ are the canonical momenta conjugate to the coordinates x, y . By Liouville's theorem the phase flow of this system, which we denote by $\{g^t\}$, preserves the ordinary Lebesgue measure in $\mathbb{R}^4 = \{X, Y, x, y\}$.

Consider the set of all points of the phase space for which the inequality $c_1 < -H < c_2$ holds, where c_1 and c_2 are sufficiently large positive constants. As we saw in § 2.5, under this assumption a point (x, y) belongs to one of the three connected subregions of the Hill region $\{V \geq c_1\}$. We choose one of the two domains containing the Sun or Jupiter. The corresponding connected domain in the phase space is clearly invariant under the action of g^t . From this domain we delete the collision trajectories, whose union has zero measure. We denote the remaining set by M and claim that M has finite measure. Indeed, the coordinates (x, y) of points in M belong to a bounded subset of the plane \mathbb{R}^2 . The admissible momenta X, Y satisfy the inequalities

$$2(V - c_2) < (Y + x)^2 + (X - y)^2 < 2(V - c_1),$$

which follow from the Jacobi integral. In the plane \mathbb{R}^2 with Cartesian coordinates X, Y these inequalities define a circular annulus, whose area is at most $2\pi(c_2 - c_1)$. These remarks imply that $\mu(M)$ is finite. Therefore we can apply Poincaré's recurrence theorem: for almost every $p \in M$ the semitrajectory $\{g^t(p), t \geq 0\}$ intersects any neighbourhood of the point p for arbitrarily large values of t . Poincaré called such motions *stable in the sense of Poisson*.

We give a quantitative version of Poincaré's recurrence theorem, which was established in [140, 443] (see also [548]) for the case where M is an n -dimensional smooth manifold.

Theorem 2.7. *Suppose that a positive function $\psi(t)$ is arbitrarily slowly increasing to $+\infty$ as $t \rightarrow +\infty$, and $\psi(t)/t^{1/n}$ is monotonically decreasing to zero as $t \rightarrow +\infty$. Then for almost every $x \in M$ there exists a sequence $t_\nu \rightarrow +\infty$ such that*

$$\rho(g^{t_\nu} x, x) < t_\nu^{-1/n} \psi(t_\nu).$$

Here ρ is some distance on M . In [443] an example is given of a volume-preserving translation g on the n -dimensional torus \mathbb{T}^n such that

$$\rho(g^t x, x) > Ct^{-1/n}, \quad C = \text{const}$$

for all $t \in \mathbb{N}$ and $x \in \mathbb{T}^n$.

2.6.2 Probability of Capture

Again let V be a measurable set of positive measure. For $n \in \mathbb{N}$ we denote by V^n the set of points in V such that $g^k(p) \in V$ for all $0 \leq k \leq n$. Obviously, $V^{n_1} \supset V^{n_2}$ if $n_1 < n_2$. The set

$$B = \bigcap_{n \geq 0} V^n$$

is measurable and $\mu(B) < \infty$. If $p \in B$, then of course $\Gamma_p^+ \in V$ for all $n \geq 0$.

Let $B^n = g^n(B)$. All the sets B^n are measurable, and again $B^{n_1} \supset B^{n_2}$ if $n_1 < n_2$. The set

$$D = \bigcap_{n \geq 0} B^n \subset B$$

is also measurable. If $p \in D$, then clearly $\Gamma_p \in V$.

Proposition 2.7. $\mu(B \setminus D) = 0$.

For this assertion not to be vacuous, one has to show first that $\mu(B) > 0$. But in concrete problems the proof of this fact may turn out to be a considerable difficulty. Proposition 2.7, which goes back to Schwarzschild, is of course valid also in the case where the time n is continuous.

For example, suppose that the system Sun–Jupiter has “captured” from the surrounding space the asteroids (the “Greeks” and “Trojans”) into a neighbourhood of the triangular libration points. Proposition 2.7 immediately tells us that the probability of this event is zero. Thus, the phenomena of “capture” in celestial mechanics should be considered only in mathematical models that take into account dissipation of energy.

The following argument of Littlewood is a more interesting application. Consider the n -body problem with the centre of mass at rest. The motion of the points is described by a Hamiltonian system; the Hamiltonian function H is regular in the domain where the mutual distances are $r_{kl} > 0$. For arbitrary $c > 1$ we consider the open set $A(c)$ of points of the phase space where

$$c^{-1} < r_{kl} < c \quad (1 \leq k < l \leq n), \quad -c < H < c.$$

Since $A(c)$ is bounded, we have $\mu(A(c)) < \infty$. Consequently, by Proposition 2.7 the set $B(c)$ of points remaining in $A(c)$ for $t \geq 0$ is larger merely by a set of measure zero than the set $D(c)$ of points that are in $A(c)$ for all $t \in \mathbb{R}$.

If $c_1 < c_2$, then clearly $A(c_1) \subset A(c_2)$, $B(c_1) \subset B(c_2)$, and $D(c_1) \subset D(c_2)$. Hence the corresponding assertion is also valid for the sets

$$A = \bigcup_{c > 1} A(c), \quad B = \bigcup_{c > 1} B(c), \quad D = \bigcup_{c > 1} D(c).$$

For points $p \in B$ the mutual distances r_{kl} for all $t \geq 0$ remain bounded above and below by some positive constants depending on p . For points $p \in D$ this property holds for all values of t . Almost all points of D belong to B .

For example, suppose that a planet system was stable “in the past”. If it captures a new body, say, a speck of dust arriving from infinity, then the resulting system of bodies will no longer have the stability property: with probability one, either a collision will occur or one of the bodies will again move away to infinity. Moreover, it is not necessarily the speck of dust that will leave the Solar System; it may be Jupiter or even the Sun that may be ejected.

2.7 Dynamics in Spaces of Constant Curvature

2.7.1 Generalized Bertrand Problem

The potential of gravitational interaction has two fundamental properties. On the one hand, this is a harmonic function in three-dimensional Euclidean space (which depends only on the distance and satisfies Laplace’s equation). On the other hand, only this potential (and the potential of an elastic spring) generates central force fields for which all the bounded orbits are closed (Bertrand’s theorem). It turns out that these properties can be extended to the more general case of three-dimensional spaces of constant curvature (the three-dimensional sphere \mathbb{S}^3 and the Lobachevskij space \mathbb{L}^3).

For definiteness we consider the case of a three-dimensional sphere. Suppose that a material particle m of unit mass moves in a force field with potential V depending only on the distance between this particle and a fixed point $M \in \mathbb{S}^3$. This problem is an analogue of the classical problem of motion in a central field. Let θ be the length (measured in radians) of the arc of a great circle connecting the points m and M . Then V is a function depending only on the angle θ . Laplace’s equation must be replaced by the Laplace–Beltrami equation:

$$\Delta V = \sin^{-2}\theta \frac{\partial}{\partial \theta} \left(\sin^2\theta \frac{\partial V}{\partial \theta} \right) = 0.$$

This equation can be easily solved:

$$V = -\gamma \frac{\cos \theta}{\sin \theta} + \alpha; \quad \alpha, \gamma = \text{const.} \quad (2.21)$$

The additive constant α is inessential. For definiteness we consider the case $\gamma > 0$. The parameter γ plays the role of the gravitational constant. Apparently, the potential (2.21) was for the first time considered by Schrödinger for the purposes of quantum mechanics [536]. In addition to the attracting centre M this force field has a repelling centre M' at the antipodal point (when $\theta = \pi$). If we regard this force field as a stationary velocity field of a fluid on \mathbb{S}^3 , then the flux of the fluid across the boundary of any closed domain not containing the points M or M' is equal to zero. These singular points M and M' can be interpreted as a sink and a source.

In the general case, where V is an arbitrary function of θ , the trajectories of the point m lie on the two-dimensional spheres \mathbb{S}^2 containing the points M and M' . This simple fact is an analogue of Corollary 1.3 (in §1.1), which relates to motion in Euclidean space.

It is also natural to consider the generalized Bertrand problem: among all potentials $V(\theta)$ determine those in whose field almost all orbits of the point m on a two-dimensional sphere are closed. This problem (from various viewpoints and in various generality) was solved in [177, 281, 351, 557]. The solution of the generalized Bertrand problem (as in the classical case) is given by the two potentials

$$V_1 = -\gamma \cot \theta, \quad V_2 = \frac{k}{2} \tan^2 \theta; \quad k, \gamma = \text{const} > 0.$$

The first is an analogue of the Newtonian potential and the second is an analogue of Hooke's potential (with k being the "elasticity coefficient"). As shown in [351], the generalized Bohlin transformation (see §2.1.3) takes the trajectories of the particle in the field with potential V_1 to the trajectories of the particle in the field with potential V_2 .

Since the orbits are closed in these two problems, by Gordon's theorem [263] the periods T of revolution in the orbits depend only on the energy h . We now give explicit formulae for the function $T(h)$ obtained in [343].

It is well known that in Euclidean space the period of oscillations of a weight on an elastic spring is independent of the energy. This is no longer true for the sphere:

$$T = \frac{2\pi}{\sqrt{k + 2h}}.$$

For the potential of Newtonian type the dependence of the period on the energy is given by the formula

$$T = \frac{\pi}{\sqrt{\gamma}} \frac{\sqrt{\frac{h}{\gamma} + \sqrt{\frac{h^2}{\gamma^2} + 1}}}{\sqrt{\frac{h^2}{\gamma^2} + 1}}. \quad (2.22)$$

The case of the Lobachevskij space can be considered in similar fashion.

2.7.2 Kepler's Laws [177, 343]

First law. *The orbits of a particle are quadrics on \mathbb{S}^3 with a focus at the attracting centre M .*

A quadric is the intersection line of the sphere with a cone of the second order whose vertex coincides with the centre of the sphere. Spherical quadrics have many properties typical of conic sections on Euclidean plane (see, for example, [105]). In particular, one can speak about their foci F_1 and F_2 : any

ray of light outgoing from F_1 on reflection from the quadric necessarily passes through the point F_2 (rays of light are, of course, great circles on \mathbb{S}^2).

It was shown in [351] that the orbits of the generalized Hooke problem (the motion of a point in the field with potential $k(\tan^2\theta)/2$) are also quadrics whose centres coincide with the attracting centre M .

At each instant there is a unique arc of a great circle connecting the centre M and the material point m (the “position vector” of the point m). Unfortunately one cannot claim that the area on \mathbb{S}^2 swept out by this arc is uniformly increasing with time. To improve this situation we introduce an imaginary point m' by replacing the spherical coordinates θ, φ of the point m by $2\theta, \varphi$. Clearly the point m' is at double the distance from the attracting centre M .

Second law. *The arc of a great circle connecting M and m' sweeps out equal areas on the sphere in equal intervals of time.*

This law is of course valid for the motion in any central field on a surface of constant curvature.

Let F_1 and F_2 be the foci of a quadric. There is a unique great circle of the sphere \mathbb{S}^2 passing through these points. The quadric divides this circle into two parts; the length of each of these two arcs may be called the major axis of the quadric. Their sum is of course equal to 2π .

Third law. *The period of revolution in an orbit depends only on its major axis.*

The main point of the proof is in verifying the equality

$$\tan a = -\frac{\gamma}{h}, \tag{2.23}$$

where a is the length of the major axis. Then it remains to use the formula for the period (2.22). Note that relation (2.23) does not depend on which of the two major axes of the quadric is chosen.

In [343] an analogue of Kepler’s equation was obtained connecting the position of the body in an orbit and the time of motion. The “eccentric” and “mean” anomalies were introduced based on appropriate spheroidal coordinates on \mathbb{S}^2 and elliptic functions.

2.7.3 Celestial Mechanics in Spaces of Constant Curvature

Having the formula for the interaction potential of Newtonian type (2.21), we can define the potential energy of n gravitating points with masses m_1, \dots, m_n :

$$V = - \sum_{i < j} \gamma m_i m_j \cot \theta_{ij}, \tag{2.24}$$

where θ_{ij} is the distance between the points m_i and m_j on the three-dimensional sphere. Formula (2.24) allows one to write down the equation of motion of n gravitating points on \mathbb{S}^3 .

This problem has many common features with the classical n -body problem in Euclidean space. However, there are also essential differences. First, the two-body problem on \mathbb{S}^3 proves to be non-integrable: there are not sufficiently many first integrals for its solution and its orbits look quite complicated (see [137]). Here the main difficulty is related to the fact that the Galileo–Newton law of inertia does not hold: the centre of mass of gravitating points no longer moves along an arc of a great circle.

Furthermore, as in the classical case, binary collisions admit regularization. However, the question whether the generalized Sundman theorem is valid for the three-body problem in spaces of constant curvature remains open. This question essentially reduces to the problem of elimination of triple collisions. Recall that in the ordinary three-body problem the absence of simultaneous collisions is guaranteed by a non-zero constant value of the angular momentum of the system of n points with respect to their centre of mass (Theorem 2.3).

Of interest is the problem of finding partial solutions for n gravitating bodies in spaces of constant curvature (similar to the classical solutions of Euler and Lagrange). Results in this direction can be found in the book [137]. The restricted three-body problem was studied in this book: relative equilibria were found and the Hill regions were constructed.

2.7.4 Potential Theory in Spaces of Constant Curvature

As established by Newton, a homogeneous sphere in three-dimensional Euclidean space does not attract interior points, and the exterior points are attracted as if by a single material point located at the centre of the sphere whose mass is equal to the mass of the sphere. Newton’s theorem on the sphere immediately implies that a homogeneous ball attracts points in the exterior in the same way as if its mass was concentrated at the centre, while the attraction force on interior points depends linearly on the distance to the centre (by Hooke’s law).

It is also known that the level surfaces of the gravitational potential of a homogeneous rod is a confocal family of ellipsoids of revolution whose foci coincide with the ends of the rod. This result was generalized by Ivory.

Consider an infinitesimally thin homogeneous layer between two similar concentric ellipsoids with common centre and the same directions of the axes, which is called an elliptic layer. It turns out that the gravitational potential inside the elliptic layer is constant (*Newton’s theorem* generalizing the theorem on the gravitation of a sphere) and the level surfaces of the potential in the exterior are ellipsoids confocal to the layer (*Ivory’s theorem*). The proofs can be found, for example, in [83].

It is easier to think of an elliptic layer as an ellipsoid with, generally speaking, non-constant *homeoid* density

$$\frac{d\sigma}{|\nabla f|},$$

where $d\sigma$ is the area element of the ellipsoid and ∇f is the gradient of the quadratic form defining the surface of the ellipsoid. The homeoid density of a sphere and of a segment is obviously constant.

It turns out that the basic theorems of the theory of Newtonian potential in \mathbb{E}^3 can be carried over (with certain reservations) to the case of a space of constant curvature [349]. For definiteness we consider the case of a sphere, which is a space with non-trivial topology. A gravitational potential of Newtonian type is defined by (2.24).

Consider on \mathbb{S}^3 a two-dimensional sphere \mathbb{S}^2 with a homogeneous mass distribution. Let θ be the latitude on \mathbb{S}^3 measured from the centre of \mathbb{S}^2 , so that $\mathbb{S}^2 = \{\theta = \theta_0\}$, $0 < \theta_0 \leq \pi/2$. One should bear in mind that on \mathbb{S}^3 there is another sphere $\mathbb{S}_-^2 = \{\theta = \pi - \theta_0\}$ congruent to \mathbb{S}^2 , whose points produce a repulsive action. The three-dimensional sphere \mathbb{S}^3 is divided by the two-dimensional spheres \mathbb{S}^2 and \mathbb{S}_-^2 into three connected domains.

The following analogue of Newton's theorem holds: the sphere \mathbb{S}^2 does not attract points lying "inside" \mathbb{S}^2 and \mathbb{S}_-^2 , while "exterior" points are attracted in exactly the same way as if the sphere was replaced by a single point at the centre of \mathbb{S}^2 , with mass equal to the mass of the whole sphere. This immediately implies the theorem on the gravitation of a homogeneous ball bounded by the sphere $\theta = \theta_0$ ($\theta_0 < \pi/2$): exterior points ($\theta_0 \leq \theta \leq \pi - \theta_0$) are attracted in the same way as if the mass of the ball was concentrated at the centre. The potential inside the ball of unit density is given by the formula

$$\frac{\pi\gamma(2\theta - \sin 2\theta) \cos \theta}{\sin \theta},$$

which is different from Hooke's potential $(k/2) \tan^2 \theta$. Only for small θ we obtain the potential of elastic interaction

$$\frac{4\gamma\pi\theta^2}{3} + o(\theta^2).$$

In the case of Euclidean space the problem of the gravitation of a segment is essentially a planar one: in any plane containing the gravitating segment the level lines of the potential form a family of ellipses with foci at the ends of the segment. The situation is similar for a space of constant curvature. In the case of \mathbb{S}^3 the role of a plane is played by a two-dimensional sphere of unit radius.

Thus, on the two-dimensional sphere

$$x^2 + y^2 + z^2 = 1 \tag{2.25}$$

we consider a segment – an arc of a great circle with end points $F_1 = (\alpha, \beta, 0)$ and $F_2 = (\alpha, -\beta, 0)$. Of course, $\alpha^2 + \beta^2 = 1$. To make the arc uniquely determined we assume that it contains the point with coordinates $(1, 0, 0)$. This arc admits the parametrization

$$x = \sin \varphi, \quad y = \cos \varphi, \quad z = 0; \quad \frac{\pi}{2} - \varphi_* \leq \varphi \leq \frac{\pi}{2} + \varphi_*,$$

where $\cos \varphi_* = \alpha$, $\sin \varphi_* = \beta$.

At a point with coordinates x, y, z the value of the potential (up to a constant factor) is equal to

$$V = \int_{\pi/2-\varphi_*}^{\pi/2+\varphi_*} \frac{\cos \tilde{\theta}}{\sin \tilde{\theta}} d\varphi,$$

where $\cos \tilde{\theta} = x \sin \varphi + y \cos \varphi$. As an analogue of a confocal family of ellipses we have the family of ovals which is the result of the intersection of the cones

$$\frac{c^2 x^2}{c^2 - \alpha^2} + \frac{c^2 y^2}{c^2 + \beta^2} + z^2 = 0 \quad (2.26)$$

and the sphere (2.25); here c is a parameter. As $c \rightarrow 0$, the ovals converge to the original segment. As already mentioned, by analogy with the Euclidean case these ovals may be called spherical conics with foci at the points F_1 and F_2 .

One can verify that the level lines of the potential V created by an arc of a great circle on \mathbb{S}^2 is a family of spherical conics with foci at the ends of the arc.

These observations admit a generalization. Let A be a symmetric operator in Euclidean space \mathbb{R}^4 , and I the identity operator. The operator $(A - \lambda I)^{-1}$ (the resolvent of A , where λ is a spectral parameter) is also a symmetric operator, which defines the pencil of quadratic forms

$$f(x) = ((A - \lambda I)^{-1} x, x).$$

Equating these forms to zero we obtain a family of cones, which intersect the three-dimensional sphere

$$g(x) = (x, x) = 1$$

in two-dimensional surfaces. These surfaces may be called spherical confocal quadrics.

Example 2.2. Dividing equation (2.26) by c^2 we obtain equations of the form $f(x) = 0$, where $A = \text{diag}(-\alpha^2, \beta^2, 0)$, $\lambda = c^2$. \triangle

On the quadrics one can define the homeoid density

$$\frac{d\sigma}{W_2},$$

where $d\sigma$ is the area element of the quadric as a surface in \mathbb{R}^4 and W_2 is the Euclidean area of the parallelogram constructed on the gradients of the functions f and g as vectors.

Theorem 2.8. *Let k be a quadric on \mathbb{S}^3 with homeoid mass density, and k_- the antipodal quadric. The potential created by k is constant in the two ball-shaped domains on \mathbb{S}^3 bounded by the quadrics k and k_- , and the level surfaces of this potential in the complementary domain form a family of quadrics confocal with k .*

This is an analogue of the classical Newton–Ivory theorem.

Ivory’s theorem admits a generalization to quadratic forms of other signatures (with ellipsoids replaced by the corresponding hyperboloids in \mathbb{R}^n); see [76, 593]. The simplest case is a one-sheet hyperboloid in \mathbb{R}^3 .

The gravitational potentials are replaced by differential forms, whose degrees are determined by the signature. For a one-sheet hyperboloid in \mathbb{R}^3 the result is 2-forms that are harmonic outside the hyperboloid and whose kernels are directed along the parallels of the elliptic coordinate system in the multiply connected component of the complement of the hyperboloid, and along the meridians, in the simply connected one. These forms can also be described as flows of an incompressible fluid along the fields of the kernels of the forms.

The corresponding magnetic fields are given by the Biot–Savart integrals over currents (generalizing the homeoid density) flowing along the meridians of the surface in the first case, and along the parallels, in the second (the field created by the current in the second component is zero).

Symmetry Groups and Order Reduction

3.1 Symmetries and Linear Integrals

3.1.1 Nöther's Theorem

Let (M, L) be a Lagrangian system and v a smooth field on M . The field v gives rise to the one-parameter group g of diffeomorphisms $g^\alpha: M \rightarrow M$ defined by the differential equation

$$\frac{d}{d\alpha}g^\alpha(x) = v(g^\alpha(x)) \quad (3.1)$$

and the initial condition $g^0(x) = x$.

Definition 3.1. The Lagrangian system (M, L) admits the group $\{g^\alpha\}$ if the Lagrangian L is invariant under the maps $g_*^\alpha: TM \rightarrow TM$. The group g can be naturally called a *symmetry group*, and the field v a *symmetry field*.

Let $\gamma: \Delta \rightarrow M$ be a motion of the Lagrangian system (M, L) . Then the composition $g^\alpha \circ \gamma: \Delta \rightarrow M$ is also a motion for every value of α .

In the non-autonomous case the Lagrangian L is a smooth function on the tangent bundle of the extended configuration space $'M = M \times \mathbb{R}$. We call a group of diffeomorphisms $'g^\alpha: 'M \rightarrow 'M$ a symmetry group of the system $('M, L)$ if $'g^\alpha(x, t) = (y, t)$ for all $(x, t) \in M \times \mathbb{R}$ and the maps $'g_*^\alpha$ preserve L . The group $\{'g^\alpha\}$ gives rise to the smooth field on $'M$

$$'v(x, t) = \frac{d}{d\alpha}('g^\alpha(x, t))_{\alpha=0}.$$

It is obvious that $'v(x, t) = (v(x, t), 0) \in T_{(x, t)}(M \times \mathbb{R})$ and $v(x, t)$ can be interpreted as a field on M smoothly depending on t .

Lemma 3.1. *The system (M, L) admits the symmetry group $\{g^\alpha\}$ if and only if*

$$(p \cdot v)' = [L] \cdot v. \quad (3.2)$$

◁ This follows from the identity

$$\left. \frac{d}{d\alpha} \right|_{\alpha=0} L(g_*^\alpha \dot{x}) = (L'_{\dot{x}} \cdot v) - [L] \cdot v. \tag{3.3}$$

▷

Lemma 3.1 is also valid in the non-autonomous case. Equality (3.2) implies the following.

Theorem 3.1. *If the system (M, L) admits the group $\{g^\alpha\}$, then $I = p \cdot v$ is a first integral of the equations of motion.¹*

Let $(M, \langle \cdot, \cdot \rangle, V)$ be a natural mechanical system. The Lagrangian $L = \langle \dot{x}, \dot{x} \rangle / 2 + V(x)$ is invariant under the action of the group g if and only if this property is enjoyed by the Riemannian metric $\langle \cdot, \cdot \rangle$ and the potential V . For natural systems the integral I is clearly equal to $\langle v, \dot{x} \rangle$; it depends linearly on the velocity.

Example 3.1. If in some coordinates x_1, \dots, x_n on M the Lagrangian L is independent of x_1 , then the system (M, L) admits (locally) the symmetry group $g^\alpha: x_1 \mapsto x_1 + \alpha, x_k \mapsto x_k \ (k \geq 2)$. This group corresponds to the vector field $v = \partial / \partial x_1$. By Theorem 3.1 the quantity $I = p \cdot v = p_1 = L'_{\dot{x}_1}$ is conserved. In mechanics, x_1 is called a *cyclic coordinate*, and the integral I a *cyclic integral*. In particular, the energy integral is a cyclic integral of a certain extended Lagrangian system. In order to show this we introduce a new time variable τ by the formula $t = t(\tau)$ and define a function $'L: T'M \rightarrow \mathbb{R}$ ($'M = M \times \mathbb{R}$) by the formula

$$'L(x', t', x, t) = L(x'/t', x, t)t', \quad (\cdot)' = \frac{d}{d\tau}(\cdot).$$

It follows from Hamilton's variational principle and the equality

$$\int_{\tau_1}^{\tau_2} 'L \, d\tau = \int_{t_1}^{t_2} L \, dt$$

that if $x: [t_1, t_2] \rightarrow M$ is a motion of the system (M, L) , then $(x, t): [\tau_1, \tau_2] \rightarrow 'M$ is a motion of the extended Lagrangian system $('M, 'L)$. In the autonomous case, time t is a cyclic coordinate and the cyclic integral

$$\frac{\partial 'L}{\partial t'} = L - \frac{\partial L}{\partial \dot{x}} \cdot \dot{x} = \text{const}$$

coincides with the energy integral. △

¹ In this form this theorem was first stated by E. Nöther in 1918. The connection between the laws of conservation of momentum and angular momentum and the groups of translations and rotations was already known to Lagrange and Jacobi. Theorem 3.1 for natural systems was published by Levy in 1878.

Theorem 3.2. *If $v(x_0) \neq 0$, then in a small neighbourhood of the point x_0 there exist local coordinates x_1, \dots, x_n such that $I = p \cdot v = p_1$.*

This assertion is a consequence of the *theorem on rectification* of a vector field.

Theorem 3.3. *Suppose that $I = p \cdot v$ is a first integral of the equation of motion $[L] = 0$. Then the phase flow of equation (3.1) is a symmetry group of the Lagrangian system (M, L) .*

Theorems 3.2 and 3.3 imply the following.

Corollary 3.1. *Integrals of natural systems that are linear in the velocities locally are cyclic.*

If there are several symmetry fields v_1, \dots, v_k , then the equation of motion admits as many first integrals $I_1 = p \cdot v_1, \dots, I_k = p \cdot v_k$. Assuming that (M, L) is a natural Lagrangian system we use the Legendre transformations to pass to Hamilton's equations on T^*M . The functions $I_1, \dots, I_k: T^*M \rightarrow \mathbb{R}$ are independent and in involution (in the standard symplectic structure on T^*M) if and only if the fields v_1, \dots, v_k are independent and commute on M . The existence of linear integrals imposes restrictions not only on the Riemannian metric and the potential of the force field, but also on the topology of the configuration space.

Theorem 3.4. *Let M be a connected compact orientable even-dimensional manifold. If a Hamiltonian natural system on T^*M has at least $(\dim M)/2$ independent linear integrals in involution, then the Euler–Poincaré characteristic of M is non-negative: $\chi(M) \geq 0$.²*

Corollary 3.2. *Suppose that $\dim M = 2$. If the natural system has a first integral that is linear in the velocity, then M is diffeomorphic to the sphere or the torus.*

In the non-orientable case one must add the projective plane and the Klein bottle.

◁ We now prove Corollary 3.2. If $\chi(M) < 0$, then the symmetry field v has singular points. Since the phase flow of the equation $\dot{x} = v(x)$ is a group of isometries of the two-dimensional Riemannian manifold $(M, \langle \cdot, \cdot \rangle)$, the singular points x_s are isolated and are of elliptic type. By Poincaré's formula, $\chi(M) = \sum_s \text{ind}(x_s) > 0$, a contradiction. ▷

We now consider a more general situation where an arbitrary Lie group G acts (on the left) on M . Let \mathcal{G} be the Lie algebra of G and let \mathcal{G}^* be the dual vector space of the space of the algebra \mathcal{G} . We shall now define a natural map $I_G: TM \rightarrow \mathcal{G}^*$ that associates with each point $\dot{x} \in TM$ a linear function on \mathcal{G} .

² This assertion was obtained by Bolotin and Abrarov (see [56]).

To each vector $X \in \mathcal{G}$ there corresponds a one-parameter subgroup g_X , whose action on M generates a tangent field v_X . The map $X \mapsto v_X$ is a homomorphism of the algebra \mathcal{G} into the Lie algebra of all vector fields on M . We set $I_G(\dot{x}) = L'_x \cdot v_X$; this function is linear in X .

Definition 3.2. The map $I_G: TM \rightarrow \mathcal{G}^*$ is called the *momentum map* of the Lagrangian system (M, L) for the action of the group G (or simply momentum if this causes no confusion).

Along with the momentum map $I_G: TM \rightarrow \mathcal{G}^*$ we have the map $P_G: T^*M \rightarrow \mathcal{G}^*$ defined by the formula $P_G(p) = p \cdot v_X$. The momentum map I_G is the composition of the map P_G and the Legendre transformation.

Example 3.2. Consider n free material points (\mathbf{r}_k, m_k) in three-dimensional Euclidean space. Let $SO(2)$ be the group of rotations of the space around the axis given by a unit vector \mathbf{e} . The group $SO(2)$ acts on the configuration space $\mathbb{R}^3\{\mathbf{r}_1\} \times \cdots \times \mathbb{R}^3\{\mathbf{r}_n\}$; the corresponding vector field is

$$(\mathbf{e} \times (\mathbf{r}_1 - \mathbf{r}'_1), \dots, \mathbf{e} \times (\mathbf{r}_n - \mathbf{r}'_n)),$$

where \mathbf{r}'_k is the position vector of the k th point with initial point at some point of the rotation axis. Since

$$L = \frac{1}{2} \sum m_k \langle \dot{\mathbf{r}}_k, \dot{\mathbf{r}}_k \rangle + V(\mathbf{r}_1, \dots, \mathbf{r}_n),$$

the momentum

$$I_{SO(2)} = \sum m_k \langle \dot{\mathbf{r}}_k, \mathbf{e} \times (\mathbf{r}_k - \mathbf{r}'_k) \rangle = \langle \mathbf{e}, \sum m_k (\mathbf{r}_k - \mathbf{r}'_k) \times \dot{\mathbf{r}}_k \rangle$$

coincides with the already known angular momentum of the system with respect to the axis.

Now let $G = SO(3)$ be the group of rotations around some point o . The dual space $\mathcal{G}^* = (so(3))^*$ can be canonically identified with the algebra of vectors of three-dimensional oriented Euclidean space where the commutator is defined as the ordinary cross product. Then $I_{SO(3)}$ will clearly correspond to the angular momentum of the system with respect to the point o . \triangle

Definition 3.3. A group G is called a *symmetry group* of the Lagrangian system (M, L) if $L(g_*\dot{x}) = L(\dot{x})$ for all $\dot{x} \in TM$ and $g \in G$.

Theorem 3.5. Suppose that the system (M, L) admits G as a symmetry group. Then the momentum map I_G is a first integral (that is, I_G takes constant values on the motions of the Lagrangian system (M, L)).

This assertion is a consequence of Theorem 3.1.

Example 3.3. We already saw in Ch. 1 that the equations of the problem of n gravitating bodies admit the Galilean transformation group. However, the Lagrange function

$$L = \frac{1}{2} \sum m_k (\dot{x}_k^2 + \dot{y}_k^2 + \dot{z}_k^2) + \sum_{i < j} \frac{\gamma m_i m_j}{\sqrt{(x_i - x_j)^2 + (y_i - y_j)^2 + (z_i - z_j)^2}}$$

is not invariant under the whole Galilean group. This function admits translations of the time axis and isometries of three-dimensional Euclidean space. Translations of the time axis correspond to the conservation of the total energy; translations of Euclidean space, to the conservation of the momentum; and the group of rotations, to the conservation of the angular momentum. We consider in addition the group of homotheties

$$(x, y, z) \mapsto (\alpha x, \alpha y, \alpha z), \quad \alpha > 0. \tag{3.4}$$

This group is generated by the vector field

$$\mathbf{v} = \sum_k x_k \frac{\partial}{\partial x_k} + y_k \frac{\partial}{\partial y_k} + z_k \frac{\partial}{\partial z_k}.$$

For $\alpha = 1$ we have the identity transformation. The Lagrangian of the n -body problem does not admit the group of homotheties. However, we can use identity (3.3) for $\alpha = 1$. Since $T \mapsto \alpha^2 T$ and $V \mapsto \alpha^{-1} V$ under the change of variables (3.4), equality (3.3) gives the already known Lagrange's identity:

$$\left. \frac{dL}{d\alpha} \right|_{\alpha=1} = (\mathbf{p} \cdot \mathbf{v})' \Leftrightarrow 2T - V = \sum_k m(x_k \dot{x}_k + y_k \dot{y}_k + z_k \dot{z}_k)' = \dot{I},$$

where $I = \sum m (x_k^2 + y_k^2 + z_k^2)$. △

3.1.2 Symmetries in Non-Holonomic Mechanics

Suppose that (M, S, L) is a non-holonomic system acted upon by additional non-conservative forces $F(\dot{x}, x): T_x M \rightarrow T_x^* M$. The motions are defined by the d'Alembert–Lagrange principle: $([L] - F) \cdot \xi = 0$ for all virtual velocities ξ .

Definition 3.4. The Lie group G is called a *symmetry group* of the non-holonomic system (M, S, L) if

- 1) G preserves L ,
- 2) the vector fields $v_X, X \in \mathcal{G}$, are fields of virtual velocities.

Definition 3.5. The *moment of the force F relative to the group G* is the map $\Phi_G: TM \rightarrow \mathcal{G}^*$ defined by the formula $\Phi_G(\dot{x}) = F \cdot v_X$.

Theorem 3.6. *If (M, S, L) admits G as a symmetry group, then $(I_G)' = \Phi_G$.*

Corollary 3.3. *If $F \equiv 0$, then under the hypotheses of Theorem 3.6 the momentum I_G is conserved.*

One can derive Theorem 3.6 from the d'Alembert–Lagrange principle using identity (3.3).

We now apply these general considerations to the dynamics of systems of material points in three-dimensional oriented Euclidean space. We assume that a force \mathbf{F} acts on a point (\mathbf{r}, m) . We consider the group of translations along a moving straight line with directional vector $\mathbf{e}(t)$: $\mathbf{r} \mapsto \mathbf{r} + \alpha \mathbf{e}$, $\alpha \in \mathbb{R}$.

Theorem 3.7 ([353]). *Suppose that the following conditions hold:*

- 1) *the vectors $\xi_k = \dot{\mathbf{e}}$ (for $1 \leq k \leq n$) are virtual velocities,*
- 2) *$\langle \mathbf{P}, \dot{\mathbf{e}} \rangle = 0$, where $\mathbf{P} = \sum m \dot{\mathbf{r}}$ is the total momentum.*

Then $\langle \mathbf{P}, \mathbf{e} \rangle = \langle \sum \mathbf{F}, \mathbf{e} \rangle$.

Corollary 3.4. *Suppose that the vectors $\xi_k = \dot{\boldsymbol{\eta}} = (\sum m \mathbf{r} / \sum m)$ (for $1 \leq k \leq n$) are virtual velocities at each instant. If the system moves freely ($\mathbf{F} \equiv 0$), then the velocity of its centre of mass $\dot{\boldsymbol{\eta}}$ is constant.*

Example 3.4. Consider a balanced skate sliding on the horizontal plane and a homogeneous disc rolling so that its plane is always vertical. By Corollary 3.4 the velocities of their centres of mass are constant. △

We also consider the group of rotations of Euclidean space around a moving straight line l with directional unit vector $\mathbf{e}(t)$ passing through a point with position vector $\mathbf{r}_0(t)$. Let \mathbf{K} be the angular momentum of a system of material points with respect to the fixed origin of reference, and let K_l and M_l be, respectively, the angular momentum and the moment of forces with respect to the moving axis l .

Theorem 3.8 ([353]). *Suppose that the following conditions hold:*

- 1) *when the system rotates as a rigid body around the axis l , the velocity vectors of the material points are virtual velocities at each instant,*
- 2) *$\langle \mathbf{P}, (\mathbf{r}_0 \times \mathbf{e}) \rangle + \langle \mathbf{K}, \mathbf{e} \rangle = 0$.*

Then $\dot{K}_l = M_l$.

In particular, if the axis l does not change its direction in space ($\mathbf{e}(t) = \text{const}$), then condition 2) becomes Chaplygin's condition (1897):

$$\langle \mathbf{e}, \dot{\mathbf{r}}_0 \times \dot{\boldsymbol{\eta}} \rangle = 0,$$

where $\dot{\boldsymbol{\eta}}$ is the velocity of the centre of mass. In the case where $\mathbf{r}_0 = \boldsymbol{\eta}$ condition 2) can be simplified to $\langle \mathbf{K} + \mathbf{r}_0 \times \mathbf{P}, \dot{\mathbf{e}} \rangle = 0$. This condition is automatically satisfied under the additional assumption that $\mathbf{e}(t) = \text{const}$. For example, a balanced skate rotates around the vertical axis with constant angular velocity.

Example 3.5. Consider *Chaplygin's problem* of the rolling on the horizontal plane of a dynamically asymmetric ball whose centre of mass coincides with its geometric centre. Let o be the contact point of the ball with the plane and let \mathbf{K}_0 be the angular momentum of the ball with respect to the point o . Chaplygin's problem admits the group $SO(3)$ of rotations around the contact point. The momentum map $I_{SO(3)}$ is of course equal to \mathbf{K}_0 , and the moment of forces is zero: $\Phi_G = 0$. Consequently, $\mathbf{K}_0 = \text{const}$ by Theorem 3.6. This observation allows us to form a closed system of differential equations of rolling of the ball. Let \mathbf{k}_0 be the angular momentum in the moving space attached to the rigid body, ω the angular velocity of rotation of the ball, and γ the unit vertical vector. The fact that the vectors \mathbf{k}_0 and γ are constant in the fixed space is equivalent to the equations

$$\dot{\mathbf{k}}_0 + \omega \times \mathbf{k}_0 = 0, \quad \dot{\gamma} + \omega \times \gamma = 0. \tag{3.5}$$

Let A be the inertia tensor of the body with respect to the centre of mass, m the mass of the ball, and a its radius. Then $\mathbf{k}_0 = A\omega + ma^2\gamma \times (\omega \times \gamma)$. This relation turns equations (3.5) into a closed system of differential equations with respect to ω and γ . Equations (3.5) have four independent integrals: $F_1 = \langle \mathbf{k}_0, \mathbf{k}_0 \rangle$, $F_2 = \langle \mathbf{k}_0, \gamma \rangle$, $F_3 = \langle \gamma, \gamma \rangle = 1$, $F_4 = \langle \mathbf{k}_0, \omega \rangle$. The last integral expresses the constancy of the kinetic energy of the rolling ball. Using these integrals one can integrate equations (3.5) by quadratures (Chaplygin, 1903). \triangle

3.1.3 Symmetries in Vakonomic Mechanics

Let (M, S, L) be a vakonomic system, and G a Lie group acting on M .

Definition 3.6. The group G is called a *symmetry group of the vakonomic system* (M, S, L) if

- 1) the group G takes $S \subset TM$ to S ,
- 2) G preserves the restriction of L to S .

Definition 3.7. The *momentum map* I_G of the vakonomic system for the action of the group G is the map $T^*M \rightarrow \mathcal{G}^*$ defined by the formula $p \mapsto p \cdot v_X$, $X \in \mathcal{G}$, where p is the vakonomic momentum.

Example 3.6. Suppose that the system (M, S, L) is natural and the kinetic energy is given by a Riemannian metric $\langle \cdot, \cdot \rangle$. If the constraint S is given by the equation $\langle a(x), \dot{x} \rangle = 0$, then

$$I = \langle v, \dot{x} \rangle + \langle p, a \rangle \langle a \cdot v \rangle / \langle a, a \rangle. \tag{\triangle}$$

Theorem 3.9. *If the vakonomic system (M, S, L) admits G as a symmetry group, then $I_G = \text{const}$.*

The function I_G is not observable in the general case. However, if the symmetry fields v_X , $X \in \mathcal{G}$, are fields of virtual velocities, then I_G is equal to $L_{\dot{x}} \cdot v_X$ and therefore is observable.

Example 3.7. A skate on the horizontal plane regarded as a vakonomic system admits the group of translations, but does not admit the group of rotations around the vertical axis. Consequently, the vakonomic momentum of the skate is conserved. However, this quantity is not observable. The vakonomic momentum map for the action of the group of rotations of the skate coincides with the ordinary angular momentum, which is not a first integral of the equations of motion. \triangle

3.1.4 Symmetries in Hamiltonian Mechanics

Let (M, ω^2) be a symplectic connected manifold and suppose that a group $g = \{g^s\}$ acts on M as a group of symplectic diffeomorphisms. The group g gives rise to the vector field

$$v = \left. \frac{d}{ds} \right|_{s=0} g^s.$$

This field is locally Hamiltonian: the 1-form $\omega^2(\cdot, v)$ is closed. Hence, locally $\omega^2(\cdot, v) = dF$. Extension of the function F to the entire manifold M leads, as a rule, to a multivalued Hamiltonian function.

Example 3.8. Let N be a smooth manifold, and $\{g^s\}$ a group of diffeomorphisms of N generated by a vector field u . Since each diffeomorphism of the manifold N takes 1-forms to 1-forms, the group $\{g^s\}$ acts also on the cotangent bundle $M = T^*N$. Recall that M has the standard symplectic structure $\omega^2 = dp \wedge dq = d(p \cdot dq)$, where p, q are “canonical” coordinates on M . Since the group $\{g^s\}$ preserves the 1-form $p \cdot dq$, it preserves the 2-form ω^2 and therefore is a group of symplectic diffeomorphisms of the manifold M . The action of $\{g^s\}$ on M is generated by the single-valued Hamiltonian function $F = p \cdot u$. \triangle

Theorem 3.10. *A group of symplectic diffeomorphisms $\{g^s\}$ with a single-valued Hamiltonian function F preserves a function $H: M \rightarrow \mathbb{R}$ if and only if F is a first integral of the Hamiltonian system with Hamiltonian function H .*

\triangleleft The proof is based on the formula

$$\left. \frac{d}{ds} \right|_{s=0} H(g^s(x)) = \{H, F\}(x). \quad \triangleright$$

We now suppose that a Lie group G has a symplectic action on M such that to each element X of the Lie algebra \mathcal{G} of G there corresponds a one-parameter subgroup with a single-valued Hamiltonian function F_X . These Hamiltonians are defined up to constant summands.

Definition 3.8. A symplectic action of G on M is called a *Poisson action* if the correspondence $X \mapsto F_X$ can be chosen so that

- 1) F_X depends linearly on X ,
- 2) $\{F_X, F_Y\} = F_{[X, Y]}$ for all $X, Y \in \mathcal{G}$.

Example 3.9. Let N be a smooth manifold, and G a Lie group acting on N . We lift the action of G on N to a symplectic action of G on T^*N as described in Example 3.8. The action thus constructed is a Poisson action. This follows from the linearity of the function $p \cdot v_X$ and the formula $\{p \cdot v_X, p \cdot v_Y\} = p \cdot [v_X, v_Y] = p \cdot v_{[X, Y]}$. \triangle

A Poisson action of the group G on M defines the natural map $P_G: M \rightarrow \mathcal{G}^*$ that associates with a point x the linear function $F_X(x)$ of the variable $X \in \mathcal{G}$ on the algebra \mathcal{G} . We call this map the *momentum map for the Poisson action* of the group G .

Proposition 3.1. *Under the momentum map P the Poisson action of the connected Lie group G is projected to the coadjoint action of the group G on \mathcal{G}^* in the sense that the following diagram is commutative:*

$$\begin{array}{ccc}
 M & \xrightarrow{g} & M \\
 P \downarrow & & \downarrow P \\
 \mathcal{G}^* & \xrightarrow{Ad^*_{g^{-1}}} & \mathcal{G}^*
 \end{array}
 .$$

Suppose that (N, L) is a Lagrangian system and a Lie group G acts on N . The Lagrangian L defines the Legendre transformation $TN \rightarrow T^*N$. The composition of the momentum map $P_G: T^*N \rightarrow \mathcal{G}^*$ for the lifted Poisson action of G on the symplectic manifold T^*N and the Legendre transformation coincides with the momentum map $I_G: TN \rightarrow \mathcal{G}^*$ of the Lagrangian system (N, L) for the action of G defined earlier.

If a function $H: M \rightarrow \mathbb{R}$ is invariant under the Poisson action of the group G , then by Theorem 3.10 the momentum map P_G is a first integral of the system with Hamiltonian function H .

In conclusion we discuss symmetries in Dirac’s generalized Hamiltonian mechanics. Suppose that (M, ω^2, H, N) is a Hamiltonian system with constraints, where $H: M \rightarrow \mathbb{R}$ is the Hamiltonian function, and N a submanifold of M (see § 1.5.1).

Theorem 3.11. *Suppose that we are given a Poisson action of a Lie group G on the symplectic manifold (M, ω^2) such that G preserves the function H and the submanifold N . Then the momentum map P_G takes constant value on the motions of the Hamiltonian system with constraints.*

3.2 Reduction of Systems with Symmetries

3.2.1 Order Reduction (Lagrangian Aspect)

If a Lagrangian system (M, L) admits a symmetry group $\{g^\alpha\}$, then it turns out that it is possible to diminish the number of the degrees of freedom of the

system. To the group g there corresponds the first integral I_g , which is always cyclic locally. First we consider the classical *Routh's method for eliminating cyclic coordinates*; then we discuss the global order reduction.

Suppose that the Lagrangian $L(\dot{q}, \dot{\lambda}, q)$ does not involve the coordinate λ . Using the equality $L'_\lambda = c$ we represent the cyclic velocity $\dot{\lambda}$ as a function of \dot{q} , q , and c . Following Routh we introduce the function

$$R_c(\dot{q}, q) = L(\dot{q}, \dot{\lambda}, q) - c\dot{\lambda}|_{\dot{\lambda}, q, c}.$$

Theorem 3.12. *A vector-function $(q(t), \lambda(t))$ is a motion of the Lagrangian system (M, L) with the constant value of the cyclic integral $I_g = c$ if and only if $q(t)$ satisfies Lagrange's equation $[R_c] = 0$.*

If there are several cyclic coordinates $\lambda_1, \dots, \lambda_k$, then for the *Routh function* one should take $R_{c_1, \dots, c_k} = L - \sum c_s \dot{\lambda}_s$.

A small neighbourhood U of a non-singular point of the symmetry field v is “regularly” foliated into the orbits of the group g (integral curves of the field v): the quotient space $N = U/g$ is a smooth manifold with Cartesian coordinates q . It is natural to call the pair (N, R_c) the (*locally*) *reduced Lagrangian system*. For example, the elimination of the polar angle in Kepler's problem (see § 2.1.1) is an example of order reduction by Routh's method.

Cyclic coordinates are not uniquely determined: among the new variables $Q = q$, $A = \lambda + f(q)$ the coordinate A is also a cyclic coordinate. Let $\widehat{L}(\dot{Q}, \dot{A}, Q) = L(\dot{q}, \dot{\lambda}, q)$. Then, obviously, $\widehat{L}'_{\dot{A}} = L'_\lambda = c$. The Routh function corresponding to the new cyclic coordinate A is $\widehat{R}_c(\dot{Q}, Q) = R_c(\dot{q}, q) + cf'_q \cdot \dot{q}$. In view of the identity $[f] \equiv 0$ the summand $c(f'_q \cdot \dot{q})$ of course does not affect the form of the equation $[R_c] = 0$. But this means that the Routh function is not uniquely determined for $c \neq 0$. These observations prove to be useful in the analysis of the global order reduction, which we shall now consider. For definiteness we shall consider the case of natural Lagrangian systems.

Let (M, N, pr, S, G) be a fibre bundle with total space M , base space N , projection $pr: M \rightarrow N$ (the rank of the differential pr_* is equal to $\dim N$ at all points of M), fibre S , and structure group G . The group G acts on the left on the fibre S freely and transitively. This action can be extended to a left action of G on M ; then all the orbits of G will be diffeomorphic to S . In the case of a principle bundle, the manifold S is diffeomorphic to the space of the group G . The base space N can be regarded as the quotient space of the manifold M by the equivalence relation defined by the action of the group G . The tangent vectors v_X , $X \in \mathcal{G}$, to the orbits of the group G are vertical: $pr_*(v_X) = 0$.

Suppose that G is a symmetry group of a natural mechanical system $(M, \langle \cdot, \cdot \rangle, V)$. We define on the bundle (M, N, pr, S, G) the “canonical” connection by declaring as horizontal the tangent vectors to M that are orthogonal in the metric $\langle \cdot, \cdot \rangle$ to all the vectors v_X , $X \in \mathcal{G}$. This connection is compatible with the structure group G : the distribution of horizontal vectors is mapped

to itself under the action of G on M . A smooth path $\gamma: [t_1, t_2] \rightarrow M$ is said to be *horizontal* if the tangent vectors $\dot{\gamma}(t)$ are horizontal for all $t_1 \leq t \leq t_2$. It is easy to verify that for any smooth path $\tilde{\gamma}: [t_1, t_2] \rightarrow N$ and any point $x_1 \in M$ lying over $\tilde{\gamma}(t_1)$ (that is, such that $pr(x_1) = \gamma(t_1)$) there exists only one horizontal path $\gamma: [t_1, t_2] \rightarrow M$ covering $\tilde{\gamma}$.

We equip the manifold $N = M/G$ with the “quotient metric” $\langle \cdot, \cdot \rangle$ by first restricting the original metric on M to the distribution of horizontal vectors and then pushing it down onto N . Since the potential $V: M \rightarrow \mathbb{R}$ is constant on the orbits of the group G , there exists a unique smooth function $\tilde{V}: N \rightarrow \mathbb{R}$ such that the following diagram is commutative:

$$\begin{array}{ccc} M & \xrightarrow{pr} & N \\ v \searrow & & \swarrow \tilde{v} \\ & \mathbb{R} & \end{array} .$$

Theorem 3.13. *The motions of the natural system $(M, \langle \cdot, \cdot \rangle, V)$ with zero value of the momentum map I_G are uniquely projected to the motions of the reduced system $(N, \langle \cdot, \cdot \rangle, \tilde{V})$.*

◁ Let $\tilde{\gamma}: [t_1, t_2] \rightarrow N$ be a motion of the reduced system, and $\tilde{\gamma}_\alpha$ its variation with fixed ends. Let $\gamma_\alpha: [t_1, t_2] \rightarrow M$ be a horizontal lifting of the path $\tilde{\gamma}_\alpha$ such that $\gamma_\alpha(t_1) = \gamma_0(t_1)$ for all α . The variation field u of the family of paths γ_α is such that $u(t_1) = 0$ and $u(t_2)$ is a vertical vector. If L (respectively, \tilde{L}) is the Lagrangian of the original (reduced) system, then by the first variation formula,

$$\delta \int_{t_1}^{t_2} \tilde{L} dt = \delta \int_{t_1}^{t_2} L dt = \langle \dot{\gamma}_0, u \rangle \Big|_{t_1}^{t_2} = 0. \quad \triangleright$$

Example 3.10. Consider the motion of a material point m in a central force field. In this problem we have the bundle $(\mathbb{R}^3 \setminus \{0\}, \mathbb{R}^+, pr, S^2, SO(3))$; the projection $pr: \mathbb{R}^3 \setminus \{0\} \rightarrow \mathbb{R}^+$ is defined by the formula $(x, y, z) \mapsto \sqrt{x^2 + y^2 + z^2}$. The Lagrangian $L = m|\dot{\mathbf{r}}|^2/2 + V(|\mathbf{r}|)$ admits the group $SO(3)$ of rotations around the point $x = y = z = 0$. If the angular momentum $I_{SO(3)}$ is equal to zero, then on $\mathbb{R}^+ = \{s > 0\}$ we obtain a one-dimensional reduced system with the Lagrangian $\tilde{L} = m\dot{s}^2/2 + V(s)$. \triangle

We now consider order reduction when the momentum map I_G is non-zero. We assume the group G to be commutative (Routh’s method can be applied only in this case). Moreover, we assume that (M, N, pr, G) is a principal bundle; in particular, the group G acts freely on M . Apart from the quotient metric $\langle \cdot, \cdot \rangle$ on the base space we shall also need the curvature form of the canonical connection. We remind the reader of the construction of this form. First we introduce the connection 1-form ω on M with values in the Lie algebra \mathcal{G} . This form is defined as follows: if $u \in TM$, then $\omega(u)$ is equal to $X \in \mathcal{G}$

such that v_X coincides with the vertical component of the vector u . In the case of a principle bundle the kernel of the homomorphism of the Lie algebra \mathcal{G} into the algebra of vector fields on M is zero; hence the connection form is well defined. For example, if $\dim G = 1$, then one can set $\omega(u) = \langle u, v \rangle / \langle v, v \rangle$, where v is the symmetry field. The curvature form Ω is a \mathcal{G} -valued 2-form such that $\Omega(u_1, u_2) = d\omega(u_1^\perp, u_2^\perp)$, where u^\perp is the horizontal component of a tangent vector u . Since G is a commutative symmetry group, the form Ω can be pushed down to N . Let $I_G = c \in \mathcal{G}^*$. Since Ω takes values in \mathcal{G} , the value of the momentum map on the curvature form is well defined: $\Omega_c = c \cdot \Omega$. The form Ω_c is an \mathbb{R} -valued form on the base space N . According to Cartan's structural equation $\Omega = d\omega + [\omega, \omega]$, the forms Ω and Ω_c are closed.

Lemma 3.2. *Let $c \in \mathcal{G}^*$. Then for every point $x \in M$ there exists a unique vertical tangent vector $w_c \in T_x M$ such that $I_G(w_c) = c$.*

Indeed, w_c is the unique element in the set $\{w \in T_x M : I_G(w) = c\}$ that has minimum length in the $\langle \cdot, \cdot \rangle$ -metric. This assertion is valid for an arbitrary group G .

Definition 3.9. The effective (or amended, or reduced) force function of the natural system with the symmetry group G corresponding to a constant value $I_G = c$ of the momentum map is the function $V_c : M \rightarrow \mathbb{R}$ equal to $V - \langle w_c, w_c \rangle / 2$.

Lemma 3.3. *The function V_c is invariant under G_c , where $G_c \subset G$ is the isotropy subgroup of the coadjoint action of G on \mathcal{G}^* at the element $c \in \mathcal{G}^*$ (see Proposition 3.1).*

Corollary 3.5. *If G is commutative, then V_c is constant on the orbits of the group G .*

This assertion allows us to define correctly the effective potential $\widetilde{U}_c = -\widetilde{V}_c$ as a function on the base space N .

Theorem 3.14. *A function $\gamma : \Delta \rightarrow M$ is a motion of the natural system $(M, \langle \cdot, \cdot \rangle, V)$ with a constant value $I_G = c$ of the momentum map if and only if the projection $\mu = pr \circ \gamma : \Delta \rightarrow N$ satisfies the differential equation*

$$[L_c]_\mu = F_c(\dot{\mu}), \tag{3.6}$$

where $L_c = \widetilde{\langle \dot{\mu}, \dot{\mu} \rangle} / 2 + \widetilde{V}_c$ and $F_c(v) = \Omega_c(\cdot, v)$.

Theorem 3.14 can be derived, for example, from Theorem 3.9.

Equation (3.6) can be regarded as the equation of motion of the natural system $(N, \widetilde{\langle \cdot, \cdot \rangle}, \widetilde{V}_c)$ under the action of the additional non-conservative forces F_c . Since $F_c(v) \cdot v = \Omega_c(v, v) = 0$, these forces do not perform work on the real motion. They are called *gyroscopic forces*.

Since the form Ω_c is closed, we have locally $\Omega_c = d\omega_c$. Consequently, (3.6) is Lagrange's equation $[R_c] = 0$, where $R_c = L_c - \omega_c$. Routh's function R_c is defined globally on TN only if the form Ω_c is exact.

Example 3.11. Consider the rotation of a rigid body with a fixed point in an axially symmetric force field. The kinetic energy and the potential admit the group $SO(2)$ of rotations around the symmetry axis of the field. In this problem, M is diffeomorphic to the underlying space of the group $SO(3)$. The reduction $SO(3)/SO(2)$ was first carried out by Poisson as follows. Let \mathbf{e} be a unit vector of the symmetry axis of the force field regarded as a vector of the moving space. The action of the subgroup $SO(2)$ on $SO(3)$ by right translations leaves \mathbf{e} invariant. The set of all positions of the vector \mathbf{e} in the moving space forms a two-dimensional sphere S^2 , called the “Poisson sphere”. The points of S^2 “number” the orbits of the rotation group $SO(2)$. Thus, we have the fibre bundle $SO(3)$ with structure group $SO(2)$ and base space S^2 . The symmetry group $SO(2)$ generates a first integral: the projection of the angular momentum of the rigid body onto the axis with directional vector \mathbf{e} is conserved. By fixing a constant value of this projection we can simplify the problem to the study of the reduced system with configuration space S^2 . Here Routh’s function is not defined globally, since the curvature form Ω is not exact:

$$\int_{S^2} \Omega = 4\pi \neq 0$$

for all values of the principal moments of inertia. We shall give explicit order-reduction formulae below. \triangle

The theory of order reduction for Lagrangian systems can be carried over, with obvious modifications, to non-holonomic mechanics. To carry out the reduction of a non-holonomic system to the quotient system by a symmetry group we need the additional assumption that the constraints be invariant under the action of this group. An example is provided by Chaplygin’s problem of a ball rolling on a horizontal plane (see Example 3.5). This problem admits the group $SO(2)$ of rotations of the ball around the vertical line passing through its centre. The group $SO(2)$ preserves the constraints, and the field generating this group is a virtual velocity field. In fact we have eliminated the rotation group in Example 3.5 using Poisson’s method.

In conclusion we also mention the “problem of *hidden motions*” or the “problem of *action at a distance*”, which agitated physicists at the end of 19th century. Suppose that a natural mechanical system with $n+1$ degrees of freedom moves freely and that its Lagrangian, representing only the kinetic energy, admits a symmetry group with field v . Reducing the order of the system we see that Routh’s function, which is the Lagrangian of the reduced system with n degrees of freedom, contains the summand (the effective potential) $\tilde{U}_c = \langle w_c, w_c \rangle / 2 = c^2 / 2 \langle v, v \rangle$, which is independent of the velocities. This summand can be interpreted as the potential of certain forces acting on the reduced system. Helmholtz, Thomson, Hertz insisted that every mechanical quantity that manifests itself as a “potential energy” is caused by hidden “cyclic” motions. A typical example is the rotation of a symmetric top: since

the rotation of the top around the symmetry axis cannot be detected, one can regard the top as non-rotating and explain its strange behaviour by the action of additional conservative forces.

Since $U_c = \langle w_c, w_c \rangle / 2 > 0$, Routh's method can produce only positive potentials. However, since a potential is defined up to an additive constant, this limitation is inessential if the configuration space is compact.

Theorem 3.15. *Let $(M, \langle \cdot, \cdot \rangle, V, \Omega)$ be a mechanical system with a closed form of gyroscopic forces Ω . If M is compact, then there exists a principal bundle with base space M and structure symmetry group \mathbb{T}^k , $k \leq \text{rank } H^2(M, \mathbb{R})$, such that after the reduction according to Routh, for some constant value $J_{\mathbb{T}^k} = c$ of the momentum map we have the equalities $V_c = V + \text{const}$, $\Omega_c = \Omega$.*

This assertion was proved by Bolotin (see [124]).

If $\Omega = 0$, then for the fibre bundle in Theorem 3.15 we can take the direct product $M \times S^1\{\varphi \bmod 2\pi\}$ with the metric $\langle \dot{x}, \dot{x} \rangle + \dot{\varphi}^2 / U(x)$, where $\langle \cdot, \cdot \rangle$ is the Riemannian metric on M . The coordinate φ is cyclic; the corresponding cyclic integral is $\dot{\varphi} / U = c$. Routh's function is $R_c = \langle \dot{x}, \dot{x} \rangle / 2 - c^2 U / 2$. For $c = \sqrt{2}$ we have a natural system on $M \times S^1 / S^1 \simeq M$ with potential U .

3.2.2 Order Reduction (Hamiltonian Aspect)

Let $F: M \rightarrow \mathbb{R}$ be a first integral of a Hamiltonian system with Hamiltonian H .

Proposition 3.2. *If $dF(z) \neq 0$, then in some neighbourhood of the point $z \in M$ there exist symplectic coordinates $x_1, \dots, x_n, y_1, \dots, y_n$ such that $F(x, y) = y_1$ and $\omega = \sum dy_k \wedge dx_k$.*

This assertion is the Hamiltonian version of the theorem on rectification of trajectories.

In the coordinates x, y the function H is independent of x_1 . Consequently, if we fix a value $F = y_1 = c$, then the system of equations

$$\dot{x}_k = H'_{y_k}, \quad \dot{y}_k = -H'_{x_k} \quad (k \geq 2)$$

is a Hamiltonian system with $n - 1$ degrees of freedom. Thus, one integral allows us to reduce the dimension of the *phase space* by two units: one integral vanishes when the value $F = c$ is fixed, and another vanishes due to the elimination of the cyclic variable x_1 along the orbit of the action of the symmetry group $\{g_F^\alpha\}$. This remark can be generalized: if a Hamiltonian system has s independent integrals in involution, then it can be reduced to a system with $n - s$ degrees of freedom. We remark that an effective use of the first integral F for order reduction is held up by the problem of finding the orbits of the group $\{g_F^\alpha\}$, which is related to integration of the Hamiltonian system with Hamiltonian F .

If the algebra of integrals is non-commutative, then the dimension of the Hamiltonian system can be reduced by at least double the maximum dimension of a commutative subalgebra. The number of commuting integrals can sometimes be increased by considering nonlinear functions of the first integrals.

Example 3.12. In the problem of the motion of a point in a central field in \mathbb{R}^3 the algebra of first integrals has a subalgebra isomorphic to the Lie algebra $so(3)$. All of its commutative subalgebras are one-dimensional. Let M_i be the projection of the angular momentum of the point onto the i th axis of a Cartesian orthogonal coordinate system. It is easy to verify that the functions M_1 and $M^2 = \sum M_i^2$ are independent and commute. Thus, this problem reduces to the study of a Hamiltonian system with one degree of freedom. \triangle

This method of order reduction for Hamiltonian systems is due to Poincaré, who applied it in various problems of celestial mechanics. This is essentially the Hamiltonian version of the order reduction according to Routh. If the algebra of integrals is non-commutative, then Poincaré’s method does not make full use of the known integrals. This shortcoming of Poincaré’s method was overcome by Cartan, who studied the general case of an infinite-dimensional Lie algebra of the first integrals (see [18]). More precisely, Cartan considered a Hamiltonian system (M, ω^2, H) with first integrals F_1, \dots, F_k such that $\{F_i, F_j\} = a_{ij}(F_1, \dots, F_k)$. The set of integrals F_1, \dots, F_k defines the natural map $F: M \rightarrow \mathbb{R}^k$. In the general case the functions $a_{ij}: \mathbb{R}^k \rightarrow \mathbb{R}$ are nonlinear.

Theorem 3.16 (Lie–Cartan). *Suppose that a point $c \in \mathbb{R}^k$ is not a critical value of the map F and has a neighbourhood where the rank of the matrix (a_{ij}) is constant. Then in a small neighbourhood $U \subset \mathbb{R}^k$ of the point c there exist k independent functions $\varphi_s: U \rightarrow \mathbb{R}$ such that the functions $\Phi_s = \varphi_s \circ F: N \rightarrow \mathbb{R}$, where $N = F^{-1}(U)$, satisfy the following relations:*

$$\{\Phi_1, \Phi_2\} = \dots = \{\Phi_{2q-1}, \Phi_{2q}\} = 1 \tag{3.7}$$

and all the other brackets are $\{\Phi_i, \Phi_j\} = 0$. The number $2q$ is equal to the rank of the matrix (a_{ij}) .

A proof can be found in [18]. Using this theorem we can now easily reduce the order. Suppose that a point $c = (c_1, \dots, c_k)$ satisfies the hypotheses of Theorem 3.16. Then, in particular, the level set $M_c = \{x \in M : \Phi_s(x) = c_s, 1 \leq s \leq k\}$ is a smooth submanifold of M of dimension $2n - k$, where $2n = \dim M$. Since the functions $\Phi_{2q+1}, \dots, \Phi_k$ commute with all the functions $\Phi_s, 1 \leq s \leq k$, their Hamiltonian fields are tangent to the manifold M_c . If these Hamiltonian fields are not hampered³ on M_c , then defined

³ A vector field is said to be *not hampered* if the motion with this field as the velocity field is defined on the time interval $(-\infty, \infty)$.

on M_c there is the action of the commutative group \mathbb{R}^l , $l = k - 2q$, generated by the phase flows of Hamilton's equations with Hamiltonians Φ_s , $s > 2q$. Since the functions Φ_s are functionally independent, the group \mathbb{R}^l acts on M_c without fixed points. If its orbits are compact (then they are l -dimensional tori), then the quotient space $M_c/\mathbb{R}^l = \widetilde{M}_c$ is a smooth manifold called the *reduced phase space*. Since $\dim \widetilde{M}_c = (2n - k) - l = 2(n - k + q)$, the manifold \widetilde{M}_c is always even-dimensional.

On the reduced phase space there exists a natural symplectic structure $\widetilde{\omega}^2$, which can be defined, for example, by a non-degenerate Poisson bracket $\{ \cdot, \cdot \}$. Let $A, B: \widetilde{M}_c \rightarrow \mathbb{R}$ be smooth functions. They can be lifted to smooth functions $'A, 'B$ defined on the level manifold $M_c \subset M$. Let $\widetilde{A}, \widetilde{B}$ be arbitrary smooth functions on M whose restrictions to M_c coincide with $'A, 'B$. We finally set $\{ \widetilde{A}, \widetilde{B} \} = \{ \widetilde{A}, \widetilde{B} \}$.

Lemma 3.4. *The bracket $\{ \cdot, \cdot \}$ is well defined (it is independent of the extensions of the smooth functions from the submanifold \widetilde{M}_c to the whole of M) and is a Poisson bracket on \widetilde{M}_c .*

Let $'H$ be the restriction of the Hamiltonian function H to the integral level M_c . Since the function $'H$ is constant on the orbits of the group \mathbb{R}^l , there exists a smooth function $\widetilde{H}: M_c/\mathbb{R}^l \rightarrow \mathbb{R}$ such that the diagram

$$\begin{array}{ccc} M_c & \xrightarrow{pr} & \widetilde{M}_c \\ 'H \searrow & & \swarrow \widetilde{H} \\ & \mathbb{R} & \end{array}$$

is commutative.

Definition 3.10. The Hamiltonian system $(\widetilde{M}_c, \widetilde{\omega}^2, \widetilde{H})$ is called the *reduced Hamiltonian system*.

Theorem 3.17. *A smooth map $\gamma: \Delta \rightarrow M$ with $F(\gamma(t)) = c$ is a motion of the Hamiltonian system (M_c, ω^2, H) if and only if the composition $pr \circ \gamma: \Delta \rightarrow \widetilde{M}_c$ is a motion of the reduced Hamiltonian system $(\widetilde{M}_c, \widetilde{\omega}^2, \widetilde{H})$.*

◁ This theorem can be established by the following considerations. Formulae (3.7) show that the functions Φ_1, \dots, Φ_k form a part of symplectic coordinates in a neighbourhood of the submanifold M_c . More precisely, in a small neighbourhood of every point of M_c one can introduce symplectic coordinates $x_1, \dots, x_n, y_1, \dots, y_n$ so that $x_i = \Phi_{2i-1}$, $y_i = \Phi_{2i}$ if $i \leq q$, and $y_i = \Phi_i$ if $i > 2q$. This assertion is a consequence of the well-known “completion lemma” of Carathéodory (see [10]). Since the functions Φ_s are first integrals, in variables x, y the Hamiltonian has the form $H(y, x) = H(y_{q+1}, \dots, y_n, x_{k-q+1}, \dots, x_n)$. It remains to fix the values of the cyclic integrals y_{q+1}, \dots, y_{k-q} and observe that the variables x_s, y_s ($s > k - q$) are local coordinates on \widetilde{M}_c in which the form $\widetilde{\omega}^2$ becomes “canonical”: $\sum_{s > k-q} dx_s \wedge dy_s$. ▷

Remark 3.1. Since the $k - q$ first integrals $\Phi_2, \dots, \Phi_{2q}, \Phi_{2q+1}, \dots, \Phi_k$ commute, one can use them for reducing the order of the Hamiltonian system according to Poincaré. The dimension of the local phase space of the reduced system will be equal to $2n - 2(k - q)$, that is, to the dimension of the manifold \widetilde{M}_c . Moreover, by Theorem 3.16 the order reductions according to Poincaré and according to Cartan give locally the same result, but the reduction by Poincaré's method can be carried out globally only under more restrictive conditions.

In degenerate cases the rank of the matrix of Poisson brackets $(\{F_i, F_j\})$ can of course drop. One can carry out the order reduction by Cartan's scheme also in this situation if in addition the integrals F_1, \dots, F_k are assumed to generate a finite-dimensional algebra (the functions $a_{ij}: \mathbb{R}^k \rightarrow \mathbb{R}$ are linear). Indeed, suppose that we have a Poisson action of the group G on the symplectic manifold (M, ω^2) . Consider the set $M_c = P^{-1}(c)$, the inverse image of some point $c \in \mathcal{G}^*$ under the momentum map $P: M \rightarrow \mathcal{G}^*$. If c is not a critical value of the momentum map P , then M_c is a smooth submanifold of M . Since the action of the group G is Poisson, by Proposition 3.1 the elements of G take the integral levels M_c one to another. Let G_c be the isotropy subgroup at a point $c \in \mathcal{G}^*$ consisting of the $g \in G$ such that $Ad_{g^*}c = c$. The group G_c is a Lie group acting on M_c . If the orbits of G_c on M_c are compact, then the reduced phase space $\widetilde{M}_c = M_c/G_c$ is a smooth manifold. Then we can define the reduced Hamiltonian system $(\widetilde{M}_c, \widetilde{\omega}^2, \widetilde{H})$ by repeating word for word the construction of order reduction according to Cartan. The connection between the original and reduced Hamiltonian systems is again described by Theorem 3.17. The proofs can be found in the works of Souriau [565] and Marsden and Weinstein [411].

Example 3.13. The motion of a material point of unit mass in a central field can be described by the Hamiltonian system in $\mathbb{R}^6 = \mathbb{R}^3\{\mathbf{x}\} \times \mathbb{R}^3\{\mathbf{y}\}$ with the standard symplectic structure and Hamiltonian function $H(\mathbf{y}, \mathbf{x}) = |\mathbf{y}|^2/2 + U(|\mathbf{x}|)$. We fix the constant angular momentum vector $\mathbf{x} \times \mathbf{y} = \boldsymbol{\mu}$ ($\boldsymbol{\mu} \neq 0$). We may assume that $\boldsymbol{\mu} = c\mathbf{e}_3$, where $\mathbf{e}_3 = (0, 0, 1)$ and $c > 0$. The level set M_c is given by the equations $x_3 = y_3 = 0$, $x_1y_2 - x_2y_1 = c$. Clearly the vector $\boldsymbol{\mu}$ is invariant under the group $SO(2)$ of rotations around the axis with unit vector \mathbf{e}_3 . To carry out the reduction with respect to this group we introduce in the plane \mathbb{R}^2 the polar coordinates r, φ and the corresponding canonical conjugate variables p_r, p_φ :

$$\begin{aligned} x_1 &= r \cos \varphi, & y_1 &= p_r \cos \varphi - \frac{p_\varphi}{r} \sin \varphi, \\ x_2 &= r \sin \varphi, & y_2 &= p_r \sin \varphi + \frac{p_\varphi}{r} \cos \varphi. \end{aligned}$$

Obviously, in the new variables the set M_c is given by the equations $x_3 = y_3 = 0$, $p_\varphi = c$. The reduction with respect to the group $SO(2)$ amounts to the elimination of the angle variable φ . Thus, the reduced phase space $\widetilde{M}_c = M_c/SO(2)$ is diffeomorphic to $\mathbb{R}^+\{r\} \times \mathbb{R}\{p_r\}$; it is equipped with the

reduced symplectic structure $\tilde{\omega}^2 = dp_r \wedge dr$. The reduced Hamiltonian has the form $\tilde{H} = (p_r^2 + c^2 r^{-2})/2 + U(r)$. △

If an element $c \in \mathcal{G}^*$ is generic (the matrix (a_{ij}) has maximum rank⁴), then the group G_c is commutative; the order reduction conducted by this scheme gives the same result as the reduction according to Cartan. If $c = 0$, then the rank of the matrix (a_{ij}) drops to zero and the integral manifold M_0 has the most “symmetric” structure: the isotropy subgroup G_0 coincides with the entire group G . In this case we have the maximal possible reduction of the order of the Hamiltonian system by $2k = 2 \dim G$ units (cf. Theorem 3.13).

Let $(N, \langle \cdot, \cdot \rangle, V)$ be a natural mechanical system, and G a compact commutative symmetry group (isomorphic to \mathbb{T}^k) acting freely on the configuration space N . We can regard this system as a Hamiltonian system with symmetries on $M = T^*N$ and apply our scheme of order reduction. There is a Poisson action of the group G on T^*N ; since this action is free, every value $c \in \mathcal{G}^*$ of the momentum map is regular. Consequently, the smooth integral level manifold \tilde{M}_c is defined (of codimension $k = \dim G$ in M), and the reduced phase space \tilde{M}_c (whose dimension is smaller by $2k$ than the dimension of M). On the other hand, we can define the smooth reduced configuration space \tilde{N} as the quotient of N by the orbits of the action of G . Moreover, for the same value $c \in \mathcal{G}^*$ we have the “seminatural” reduced Lagrangian system $(\tilde{N}, \tilde{\langle \cdot, \cdot \rangle}, \tilde{V}_c, \Omega_c)$ (see § 3.1.2, Theorem 3.13). It is appropriate to define the *reduced Lagrangian* $\tilde{L}: T\tilde{N} \rightarrow \mathbb{R}$ as the function given by the equality $\tilde{L}(\dot{x}) = \langle \dot{x}, \dot{x} \rangle / 2 + \tilde{V}_c(x)$.

Theorem 3.18. *For every $c \in \mathcal{G}^*$ there exists a diffeomorphism $f: \tilde{M}_c \rightarrow T^*\tilde{N}$ such that*

- 1) $f^*\tilde{\omega}^2 = \Omega + \Omega_c$, where Ω is the standard symplectic structure on $T^*\tilde{N}$,
- 2) the function $f \circ \tilde{H}: T^*\tilde{N} \rightarrow \mathbb{R}$ is the Legendre transform of the reduced Lagrangian defined by the metric $\tilde{\langle \cdot, \cdot \rangle}$.

Corollary 3.6. *The manifold \tilde{M}_0 is symplectically diffeomorphic to $T^*\tilde{N}$.*

If the group G is non-commutative, then the reduced phase space \tilde{M}_c in general does not coincide with the cotangent bundle of any smooth manifold.

Suppose that we have a free Poisson action of a commutative group G on a symplectic manifold (M, ω^2) . In this case the passage to the reduced manifold $(\tilde{M}_c, \tilde{\omega}^2)$ can also be realized as follows. Consider the quotient manifold $N = M/G$ and the bracket $\{ \cdot, \cdot \}$ on it which is the original Poisson bracket $\{ \cdot, \cdot \}$ pushed down to N . It is easy to see that the bracket $\{ \cdot, \cdot \}$ is degenerate.

⁴ In the case of a Poisson algebra of integrals one should, perhaps, better speak about the rank of the bilinear form $\{F_X, F_Y\}$, $X, Y \in \mathcal{G}$.

If $P: M \rightarrow \mathcal{G}^*$ is the momentum map, then there exists a smooth map $\tilde{P}: N \rightarrow \mathcal{G}^*$ such that the diagram

$$\begin{array}{ccc} M & \xrightarrow{pr} & N \\ P \searrow & & \swarrow \tilde{P} \\ & \mathcal{G}^* & \end{array}$$

is commutative. Since G acts freely, a point $c \in \mathcal{G}^*$ is a critical value of the map P if and only if c is a critical value of \tilde{P} . Assuming that $c \in \mathcal{G}^*$ is a regular point we consider the smooth manifold $N_c = \tilde{P}^{-1}(c)$ and the restriction of the bracket $\{ , \}$ to N_c .

Proposition 3.3. *The restriction of the bracket $\{ , \}$ to N_c defines a symplectic structure ω^2 , and the manifolds $(\tilde{M}_c, \tilde{\omega}^2)$ and (N_c, ω^2) are symplectically diffeomorphic.*

This remark can be generalized to the case of a non-commutative group G , but taking the quotient of M with respect to the whole group G must be replaced by the reduction with respect to the centre of G .

Example 3.14. In the problem of rotation of a rigid body with a fixed point we have $M = TSO(3) = SO(3) \times \mathbb{R}^3$. If the body rotates in an axially symmetric force field, then there is the one-parameter symmetry group $G = SO(2)$. The quotient manifold $M/SO(2)$ is diffeomorphic to $S^2 \times \mathbb{R}^3$. The equations of motion on this five-dimensional manifold can be written as the Euler–Poisson equations

$$\dot{\mathbf{k}} + \boldsymbol{\omega} \times \mathbf{k} = V' \times \mathbf{e}, \quad \dot{\mathbf{e}} + \boldsymbol{\omega} \times \mathbf{e} = 0 \quad (|\mathbf{e}| = 1),$$

where $\mathbf{k} = A\boldsymbol{\omega}$ is the angular momentum and $V: S^2 \rightarrow \mathbb{R}$ is the force function (see § 1.2). The bracket $\{ , \}$ in $S^2 \times \mathbb{R}^3$ is defined by the following formulae:

$$\begin{aligned} \omega_1, \omega_2 \} &= -\frac{A_3\omega_3}{A_1A_2}, \quad \dots, \quad \omega_1, e_1 \} = 0, \\ \omega_1, e_2 \} &= -\frac{e_3}{A_1}, \quad \omega_1, e_3 \} = \frac{e_2}{A_1}, \quad \dots, \quad \{e_i, e_j\} = 0. \end{aligned} \tag{3.8}$$

The Euler–Poisson equations have the integral $\langle \mathbf{k}, \mathbf{e} \rangle = c$ generated by the symmetry group $SO(2)$. We fix a constant value of this integral and consider the four-dimensional integral level $N_c = \{ \boldsymbol{\omega}, \mathbf{e}: \langle A\boldsymbol{\omega}, \mathbf{e} \rangle = c, \langle \mathbf{e}, \mathbf{e} \rangle = 1 \}$, which is diffeomorphic to the tangent bundle of the Poisson sphere $S^2 = \{ \mathbf{e} \in \mathbb{R}^3: \langle \mathbf{e}, \mathbf{e} \rangle = 1 \}$. We set $\boldsymbol{\omega} = \omega + c\mathbf{e}/\langle A\mathbf{e}, \mathbf{e} \rangle$; the vector ω is a horizontal tangent vector in the canonical connection of the principal bundle $(SO(3), S^2, SO(2))$ generated by the invariant Riemannian metric $\langle A\boldsymbol{\omega}, \boldsymbol{\omega} \rangle/2$. The projection $SO(3) \rightarrow S^2$ allows us to identify the horizontal vectors ω with the tangent vectors to the Poisson sphere. Let \langle , \rangle be the

quotient metric on S^2 given by $\langle \widetilde{\mathbf{a}}, \widetilde{\mathbf{b}} \rangle = \langle \mathbf{a}, A\mathbf{b} \rangle$. The Lagrange function of the reduced system is obviously equal to

$$\frac{1}{2} \langle A\boldsymbol{\omega}, \boldsymbol{\omega} \rangle + V(\mathbf{e}) = \frac{1}{2} \langle \widetilde{\boldsymbol{\omega}}, \widetilde{\boldsymbol{\omega}} \rangle + \widetilde{V}_c(\mathbf{e}),$$

where $\widetilde{V}_c = V - c^2/2 \langle A\mathbf{e}, \mathbf{e} \rangle$ is the effective force function. In the variables $\widetilde{\boldsymbol{\omega}}, \mathbf{e}$ the standard symplectic structure on T^*S^2 is given by (3.8). For $c \neq 0$ the reduced structure on T^*S^2 can also be defined by (3.8), only summands proportional to the constant c must be added to the right-hand sides. \triangle

3.2.3 Examples: Free Rotation of a Rigid Body and the Three-Body Problem

First we consider the Euler problem of the free rotation of a rigid body around a fixed point (see §1.2.4). Here $M = TSO(3) = SO(3) \times \mathbb{R}^3$, the symmetry group G is the rotation group $SO(3)$; the corresponding Poisson algebra of first integrals is isomorphic to the Lie algebra $so(3)$. We fix a value of the angular momentum $c \in \mathcal{G}^* \simeq \mathbb{R}^3$ and consider the integral level $M_c = P_{SO(3)}^{-1}(c)$. It is easy to show that for any value of c the set M_c is a three-dimensional manifold diffeomorphic to the space of the group $SO(3)$. The isotropy group G_c is the one-dimensional group $SO(2)$ of rotations of the rigid body in the stationary space around the constant vector of angular momentum. The reduced phase space $\widetilde{M}_c = SO(3)/SO(2)$ is diffeomorphic to the two-dimensional sphere.

This reduction can be realized, for example, as follows. Since the Hamiltonian vector field on M admits the group G , this field can be pushed down to the quotient space $M/G \simeq \mathbb{R}^3$. The differential equation emerging on \mathbb{R}^3 is the Euler equation

$$\dot{\mathbf{k}} + \boldsymbol{\omega} \times \mathbf{k} = 0, \quad \boldsymbol{\omega} = A^{-1}\mathbf{k}.$$

This equation can be represented in the Hamiltonian form $\dot{F} = \{F, H\}$, where $H = \langle \mathbf{k}, \boldsymbol{\omega} \rangle / 2$ is the kinetic energy of the rigid body, and the bracket $\{, \}$ is defined by the equalities $\{k_1, k_2\} = -k_3$, $\{k_2, k_3\} = -k_1$, $\{k_3, k_1\} = -k_2$. However, this bracket is degenerate: the function $F = \langle \mathbf{k}, \mathbf{k} \rangle$ commutes with all the functions defined on $\mathbb{R}^3 = \{\mathbf{k}\}$. We obtain a non-degenerate Poisson bracket by restricting the bracket $\{, \}$ to the level surface $F = |c|^2$, which is diffeomorphic to the two-dimensional sphere S^2 . The required Hamiltonian system arises on the symplectic manifold S^2 ; its Hamiltonian function is the total energy $\langle \mathbf{k}, \boldsymbol{\omega} \rangle / 2$ restricted to S^2 .

We now describe the classical method of reducing the Euler problem to a Hamiltonian system with one degree of freedom based on the special canonical variables. Let $oXYZ$ be a stationary trihedron with origin at the fixed point, and let $oxyz$ be the moving coordinate system (the principal inertia axes of the body). A position of the rigid body in the fixed space is determined by the three *Euler angles*: ϑ (nutation angle) is the angle between the axes oZ and oz ,

φ (proper rotation angle) is the angle between the axis ox and the intersection line of the planes oxy and oXY (called the line of nodes), ψ (precession angle) is the angle between the axis oX and the line of nodes. The angles ϑ, φ, ψ form a coordinate system on $SO(3)$ similar to the geographical coordinates on a sphere, which is singular at the poles (where $\vartheta = 0, \pi$) and multivalued on one meridian. Let $p_\vartheta, p_\varphi, p_\psi$ be the canonical momenta conjugate to the coordinates ϑ, φ, ψ . If the rigid body rotates in an axially symmetric force field with symmetry axis oZ , then the Hamiltonian function is independent of the angle ψ . The order reduction in this case can be interpreted as the “elimination of the node”, that is, the elimination of the cyclic variable ψ which defines the position of the line of nodes in the fixed space.

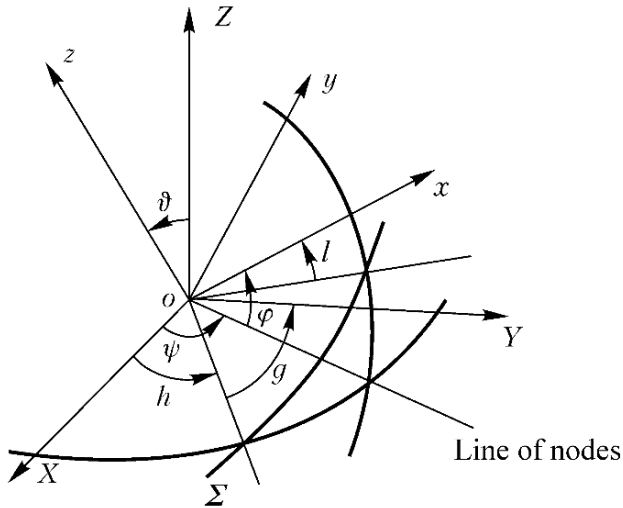

Fig. 3.1. Special canonical variables

We now introduce the “special canonical variables” L, G, H, l, g, h . Let Σ be the plane passing through the point o and perpendicular to the angular momentum vector of the body. Then L is the projection of the angular momentum onto the axis oz , G is the magnitude of the angular momentum, H is the projection of the angular momentum onto the axis oZ , l is the angle between the axis ox and the intersection line of Σ and the plane oxy , g is the angle between the intersection lines of Σ and the planes oxy and oXY , h is the angle between the axis oX and the intersection line of Σ and the plane oXY .

Proposition 3.4. *The transformation $(\vartheta, \varphi, \psi, p_\vartheta, p_\varphi, p_\psi) \mapsto (l, g, h, L, G, H)$ is “homogeneous” canonical:*

$$p_\vartheta d\vartheta + p_\varphi d\varphi + p_\psi d\psi = L dl + G dg + H dh.$$

This assertion is due to Andoyer; non-canonical variables similar to the elements L, G, H, l, g, h were used by Poisson in the analysis of the rotational motion of celestial bodies [65].

It is easy to obtain from the definition of the special canonical variables that $A_1\omega_1 = \sqrt{G^2 - L^2} \sin l$, $A_2\omega_2 = \sqrt{G^2 - L^2} \cos l$, and $A_3\omega_3 = L$. Consequently, in the Euler problem the Hamiltonian function reduces to the form

$$\frac{1}{2}(A_1\omega_1^2 + A_2\omega_2^2 + A_3\omega_3^2) = \frac{1}{2}\left(\frac{\sin^2 l}{A_1} + \frac{\cos^2 l}{A_2}\right)(G^2 - L^2) + \frac{L^2}{2A_3}.$$

For a fixed value of the magnitude of the angular momentum G_0 , the variables L, l vary within the annulus $|L| \leq G_0$, $l \bmod 2\pi$. The level lines of the Hamiltonian function are shown in Fig. 3.2. The curves $L = \pm G_0$ correspond to the singular points of the Euler equations – the permanent rotations of the body around the inertia axis oz . It is natural to regard the variables L, l as geographical symplectic coordinates on the reduced phase space S^2 .

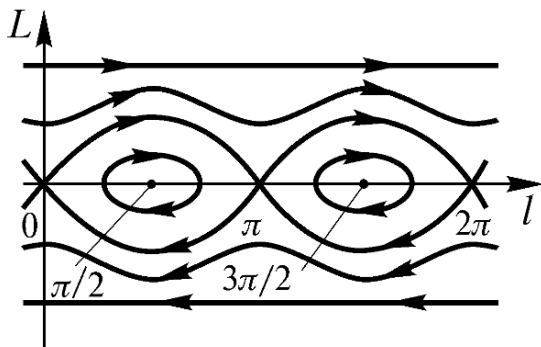

Fig. 3.2.

We now consider from the viewpoint of order reduction the three-body problem, which has 9 degrees of freedom (in the spatial case). We shall show that using the six integrals of momentum and angular momentum one can reduce the equations of motion of the three gravitating bodies to a Hamiltonian system with 4 degrees of freedom. Using also the energy integral we conclude that the three-body problem reduces to studying a dynamical system on a certain seven-dimensional manifold. In the case where the three bodies are permanently situated in a fixed plane, the dimension of this manifold is equal to five. These results go back to Lagrange and Jacobi.

We pass to a barycentric coordinate system and first use the three-dimensional commutative group of translations. Using this group we reduce the dimension of Hamilton's equations of motion from 18 to 12. The resulting reduced system, as the original one, has the symmetry group $G = SO(3)$. Fixing a value of the angular momentum we arrive at the equations of motion on a

nine-dimensional integral manifold. Taking its quotient by the isotropy subgroup of rotations around the constant angular momentum vector we obtain the required Hamiltonian system with eight-dimensional phase space. Now the question is how this reduction can be carried out explicitly.

First we eliminate the motion of the centre of mass. Let \mathbf{r}_s be the position vectors of the point masses m_s in a barycentric frame of reference, so that $\sum m_s \mathbf{r}_s = 0$. In order to use this relation for order reduction of the differential equations of motion

$$m_s \ddot{\mathbf{r}}_s = V'_{\mathbf{r}_s} \quad (1 \leq s \leq 3), \quad V = \sum_{i < j} \frac{m_i m_j}{r_{ij}}, \quad (3.9)$$

we introduce the relative position vectors $\boldsymbol{\xi} = \mathbf{r}_2 - \mathbf{r}_1$, $\boldsymbol{\eta} = \mathbf{r}_3 - \boldsymbol{\zeta}$, where $\boldsymbol{\zeta} = (m_1 \mathbf{r}_1 + m_2 \mathbf{r}_2)/(m_1 + m_2)$ is the centre of mass of the points m_1 and m_2 . We set $\mu = m_1 m_2 / (m_1 + m_2)$ and $\nu = (m_1 + m_2) m_3 / \sum m_s$.

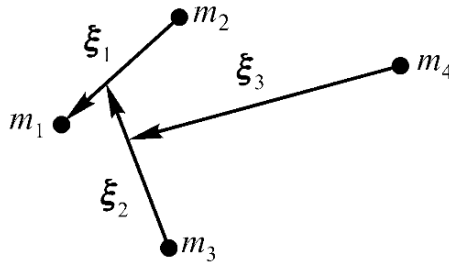

Fig. 3.3. Elimination of the centre of mass in the n -body problem

Proposition 3.5. *If $\mathbf{r}_s(t)$ is a motion of the gravitating points, then the functions $\boldsymbol{\xi}(t)$ and $\boldsymbol{\eta}(t)$ satisfy the equations*

$$\mu \ddot{\boldsymbol{\xi}} = W'_{\boldsymbol{\xi}}, \quad \nu \ddot{\boldsymbol{\eta}} = W'_{\boldsymbol{\eta}}, \quad W(\boldsymbol{\xi}, \boldsymbol{\eta}) = V|_{\boldsymbol{\xi}, \boldsymbol{\eta}}. \quad (3.10)$$

These equations have the first integral

$$\mu(\boldsymbol{\xi} \times \dot{\boldsymbol{\xi}}) + \nu(\boldsymbol{\eta} \times \dot{\boldsymbol{\eta}}) = \sum m_s(\mathbf{r}_s \times \dot{\mathbf{r}}_s) = \mathbf{c}.$$

Equations (3.10) describe the motion of the “fictitious” material points with masses μ, ν . Proposition 3.5 can be easily generalized to the case of any $n > 3$. Equations (3.10) with 6 degrees of freedom are of course Hamiltonian.

Elimination of the angular momentum (“elimination of the node”) can be carried out for equations (3.10). However, it is easier to state the final result independently in a symmetric form with respect to the masses m_1, m_2, m_3 . Let Σ be the “Laplacian invariant plane”: it contains the barycentre and is perpendicular to the constant angular momentum \mathbf{c} . Let Π be the plane

passing through the points m_1, m_2, m_3 . We denote by ϑ_i the angle of the triangle $m_1m_2m_3$ at the vertex m_i , and by Δ the area of this triangle. We have the formulae

$$\sin \vartheta_i = \frac{2\Delta}{\rho_j\rho_k}, \quad \cos \vartheta_i = \frac{\rho_i^2 - \rho_j^2 - \rho_k^2}{2\rho_j\rho_k}, \quad \Delta = \frac{\Pi\sqrt{\rho_j + \rho_k - \rho_i}}{4\sqrt{\sum \rho_s}}, \quad (3.11)$$

where i, j, k are allowed to be only the three cyclic permutations of the indices 1, 2, 3, and ρ_i is the length of the side of the triangle opposite the vertex m_i . Let γ be the angle between the planes Π and Σ ; in the planar motion, $\gamma \equiv 0$.

Proposition 3.6. *For a fixed value $\mathbf{c} = \sum m_s(\mathbf{r}_s \times \dot{\mathbf{r}}_s)$ of the angular momentum, in barycentric coordinates the equations of the three-body problem reduce to the following Hamilton's equations with four degrees of freedom:*

$$\dot{\Gamma} = -H'_\gamma, \quad \dot{\gamma} = H'_\Gamma; \quad \dot{P}_s = -H'_{\rho_s}, \quad \dot{\rho}_s = H'_{P_s} \quad (1 \leq s \leq 3); \quad (3.12)$$

$$\begin{aligned} H(\Gamma, P_1, P_2, P_3, \gamma, \rho_1, \rho_2, \rho_3) &= \\ &= \frac{|\mathbf{c}|^2 \sin \gamma}{4\Delta} \sum \frac{\rho_s^2}{m_s} \sin^2 \left(\frac{\Gamma}{|\mathbf{c}| \sin \gamma} + \frac{\vartheta_j - \vartheta_k}{3} \right) \\ &\quad + \sum \frac{P_j^2 + P_k^2 - 2P_jP_k \cos \vartheta_i}{2m_i} + |\mathbf{c}| \cos \gamma \sum \left(\frac{P_j}{\rho_k} - \frac{P_k}{\rho_j} \right) \frac{\sin \vartheta_i}{3m_i} \\ &\quad + |\mathbf{c}|^2 \cos^2 \gamma \sum \frac{\rho_j^2 + \rho_k^2 - \rho_i^2/2}{36m_i\rho_j^2\rho_k^2} - \sum \frac{m_jm_k}{\rho_i}, \end{aligned}$$

where the quantities $\Delta, \vartheta_1, \vartheta_2,$ and ϑ_3 are expressed by formulae (3.11) as functions of $\rho_1, \rho_2, \rho_3,$ and $\sum f_{ijk}$ denotes the sum $f_{123} + f_{231} + f_{312}$.

This proposition is due to van Kampen and Wintner [301]. The proof is based on elementary but cumbersome calculations. The expressions of the momenta Γ, P_s in terms of the coordinates and velocities of the gravitating points are very cumbersome and usually are not used.

When the motion is planar, then the first two equations (3.12) reduce to the equalities $\Gamma = \gamma = 0$ and we obtain a Hamiltonian system with three degrees of freedom.

If $\mathbf{c} = \mathbf{0}$, then equations (3.12) form a natural Hamiltonian system with three degrees of freedom (cf. Theorem 3.13).

3.3 Relative Equilibria and Bifurcation of Integral Manifolds

3.3.1 Relative Equilibria and Effective Potential

We again return to the study of a Hamiltonian system (M, ω^2, H) admitting a symmetry group G with a Poisson action on the phase space M . Let $(\widetilde{M}, \widetilde{\omega}^2, \widetilde{H})$ be the reduced Hamiltonian system in the sense of § 3.2.2.

Definition 3.11. The phase curves of the Hamiltonian system on M with a constant value $P_G = c$ of the momentum map that are taken by the projection $M \rightarrow \widetilde{M}_c$ to equilibrium positions of the reduced Hamiltonian system are called *relative equilibria* or *stationary motions*.

Example 3.15. Consider the rotation of a rigid body in an axially symmetric force field. Let c be a fixed value of the angular momentum of the body with respect to the symmetry axis of the force field. The equations of motion of the reduced system can be represented in the form

$$A\dot{\omega} = A\omega \times \omega - \mathbf{e} \times V', \quad \dot{\mathbf{e}} = \mathbf{e} \times \omega; \quad \langle A\omega, \mathbf{e} \rangle = c, \quad \langle \mathbf{e}, \mathbf{e} \rangle = 1, \quad (3.13)$$

where $V(e)$ is the force function. At an equilibrium position of the reduced system we obviously have $\mathbf{e} = \text{const}$ and therefore $\omega = \lambda\mathbf{e}$. The factor λ can be uniquely determined from the equation $\langle A\omega, \mathbf{e} \rangle = c$, which gives $\lambda = c/\langle A\mathbf{e}, \mathbf{e} \rangle$. Since $\mathbf{e} = \text{const}$, the angular velocity ω is also constant. From the first equation (3.13) we obtain the following equation for finding the relative equilibria with the angular momentum c :

$$c^2(A\mathbf{e} \times \mathbf{e}) + (V' \times \mathbf{e})\langle A\mathbf{e}, \mathbf{e} \rangle^2 = 0, \quad \langle \mathbf{e}, \mathbf{e} \rangle = 1.$$

This result was first noted by Staude in 1894. In a stationary motion (a relative equilibrium) the rigid body rotates uniformly around the symmetry axis of the force field with the angular velocity $|\omega| = |c|/\langle A\mathbf{e}, \mathbf{e} \rangle$. \triangle

Proposition 3.7. *A phase curve $x(t)$ of the Hamiltonian system (M, ω^2, H) with the symmetry group G is a relative equilibrium if and only if $x(t) = g^t(x(0))$, where $\{g^t\}$ is a one-parameter subgroup of G .*

\triangleleft If $x(t) = g^t(x_0)$ and $\{g^t\}$ is a subgroup of G , then the projection $M \rightarrow \widetilde{M}_c$ takes the solution $x(t)$ to an equilibrium position of the reduced system. Conversely, suppose that $x(t) = h^t(x_0)$ is a relative equilibrium of the Hamiltonian system with Hamiltonian H satisfying the initial condition $x(0) = x_0$. We claim that $\{h^t\}$ is a subgroup of G . Let $\{g^t\}$ be a one-parameter subgroup of G such that

$$\left. \frac{d}{dt} \right|_{t=0} g^t(x_0) = \dot{x}(0) \quad \left(= \left. \frac{d}{dt} \right|_{t=0} h^t(x_0) \right). \quad (3.14)$$

Since G is a symmetry group, the groups $\{h^s\}$ and $\{g^t\}$ commute and therefore $x(t) = g^t(x_0)$ by (3.14). \triangleright

In Example 3.15 above, the trajectories of stationary motions are the orbits of the group $SO(2)$ of rotations of the body around the symmetry axis of the field.

For natural mechanical systems with symmetries one can state a more effective criterion for a motion to be stationary. Let $(M, \langle \cdot, \cdot \rangle, V)$ be a mechanical system with a symmetry group (in the sense of § 3.2.1): the manifold M is the space of a principal bundle with base space N and structure group G .

Proposition 3.8. *If the symmetry group G is commutative, then $y \in N$ is a relative equilibrium position (that is, the projection of a relative equilibrium onto the base N) with momentum constant $c \in \mathcal{G}^*$ if and only if y is a critical point of the effective potential $\tilde{U}_c: N \rightarrow \mathbb{R}$.*

This assertion follows from Theorem 3.14 and the definition of a relative equilibrium. For example, since any smooth function on the sphere has at least two critical points, Proposition 3.8 implies the following.

Corollary 3.7. *The problem of rotation of a rigid body with a fixed point in any axially symmetric force field has at least two distinct stationary rotations for every value of the angular momentum.*

One can estimate the number of distinct stationary motions in the general case, for example, using Morse's inequalities. However, it is usually possible to obtain more precise information in concrete problems (see §§ 3.3.3–3.3.4).

3.3.2 Integral Manifolds, Regions of Possible Motion, and Bifurcation Sets

Let (M, ω^2, H, G) be a Hamiltonian system with a Poisson symmetry group G . Since the Hamiltonian H is a first integral, it is natural to combine this function with the momentum integrals $P: M \rightarrow \mathcal{G}^*$ and consider the smooth energy–momentum map $H \times P: M \rightarrow \mathbb{R} \times \mathcal{G}^*$.

Definition 3.12. We define the *bifurcation set* Σ of the Hamiltonian system (M, ω^2, H, G) as the set of points in $\mathbb{R} \times \mathcal{G}^*$ over whose neighbourhoods the map $H \times P$ is not a locally trivial bundle.

In particular, the set Σ' of critical values of the energy–momentum map is contained in Σ . However, in the general case the set Σ is not exhausted by Σ' . An example is provided by the bifurcation set of Kepler's problem considered in § 2.1.

Proposition 3.9. *The critical points of the map $H \times P: M \rightarrow \mathbb{R} \times \mathcal{G}^*$ on a regular level of the momentum map coincide with the relative equilibria.*

This simple assertion proves to be useful in the study of the structure of bifurcation sets.

Definition 3.13. For fixed values of the energy $h \in \mathbb{R}$ and the momentum map $c \in \mathcal{G}^*$ the set $I_{h,c} = (H \times P)^{-1}(h, c)$ is called the *integral manifold* of the Hamiltonian system (M, ω^2, H, G) .

It is obvious that the integral levels $I_{h,c}$ may not be smooth manifolds only for $(h, c) \in \Sigma$. Since the action of the group G preserves the function H , the isotropy group G_c acts on the level $I_{h,c}$ and therefore the quotient manifold

$\tilde{I}_{h,c} = I_{h,c}/G_c$ is defined. If c is a regular value of the momentum map, then $\tilde{I}_{h,c}$ coincides with an energy level of the reduced Hamiltonian system $(\tilde{M}_c, \tilde{\omega}^2, \tilde{H})$. It is therefore natural to call the set $\tilde{I}_{h,c}$ the *reduced integral manifold*. For example, in the spatial three-body problem typical manifolds $\tilde{I}_{h,c}$ are seven-dimensional, and in the planar problem their dimension is five. Since the map $H \times P$ is a bundle over each connected component of $\mathbb{R} \times \mathcal{G}^* \setminus \Sigma$, the topological type of the integral manifolds $\tilde{I}_{h,c}$ can change only as the point (h,c) passes through the bifurcation set Σ .

Thus, the study of the original Hamiltonian system with symmetries reduces to the study of the map $H \times P$ and the structure of the phase flows on the reduced integral manifolds $\tilde{I}_{h,c}$.

We consider in more detail the structure of the energy–momentum map for a natural mechanical system $(M, \langle \cdot, \cdot \rangle, V)$ with a symmetry group G ; we are not assuming the action of G on M to be free. Let Λ be the set of points $x \in M$ such that the isotropy subgroup G_x (consisting of $g \in G$ such that $g(x) = x$) has positive dimension. The set Λ is closed in M . For example, in the spatial three-body problem Λ consists of collinear triples of points. In the planar problem Λ reduces to the single point $r_1 = r_2 = r_3 = 0$ (as usual we assume that the barycentre is at the origin of reference).

Let $J: \dot{x} \rightarrow \langle \dot{x}, v_X \rangle$ be the momentum map. By Lemma 3.2, for every point $x \in M \setminus \Lambda$ and every $c \in \mathcal{G}^*$ there exists a unique vector $w_c(x)$ such that $J(w_c) = c$ and $\langle w_c, v_X \rangle = 0$ for all $X \in \mathcal{G}$. In §3.2.1 we defined the effective potential $U_c: M \rightarrow \mathbb{R}$ to be the function $-V + \langle w_c, w_c \rangle/2$.

Proposition 3.10. *The effective potential has the following properties:*

- 1) $U_c(x) = \min_{v \in J_x^{-1}(c)} H(v)$, where $H(v) = \langle v, v \rangle/2 - V(x)$ is the total energy of the system;
- 2) on $M \setminus \Lambda$ the set of critical points of the map $H: J^{-1}(c) \rightarrow \mathbb{R}$ coincides with $w_c(\Gamma)$, where Γ is the set of critical points of the effective potential $U_c: M \setminus \Lambda \rightarrow \mathbb{R}$;
- 3) $\Sigma' = \{(h,c): h \in U_c(\Gamma)\}$;
- 4) $\pi(I_{h,c}) = U_c^{-1}(-\infty, h]$, where $\pi: TM \rightarrow M$ is the projection.

This proposition was stated by Smale; in concrete situations it had been used even earlier by various authors. Part 2) refines Proposition 3.9.

Definition 3.14. The set $\pi(I_{h,c}) \subset M$ is called the *region of possible motion* for the fixed values of the energy h and the momentum map c .

If the group G is commutative, then part 4) of Proposition 3.10 can be replaced by

- 4') $\pi'(\tilde{I}_{h,c}) \subset \tilde{U}_c^{-1}(-\infty, h]$, where $\pi': TN \rightarrow N$ is the projection, $N = M/G$ is the reduced configuration space, and $\tilde{U}_c: N \rightarrow \mathbb{R}$ is the effective potential.

If M is compact, then $\Sigma = \Sigma'$ and inclusion in 4') can be replaced by equality. In the non-compact case this is no longer true: a counterexample is provided by the spatial n -body problem. It is interesting to note that in the planar n -body problem the region of possible motion is described by the inequality $U_c \leq h$ (Proposition 1.8 in § 1.1.5).

3.3.3 The Bifurcation Set in the Planar Three-Body Problem

Proposition 3.11. *For any given set of masses in the planar three-body problem,*

- (1) *in the coordinates h, c , the set of critical values Σ' of the map $H \times J$:
 $TM \rightarrow \mathbb{R}^2$ consists of the four cubic curves given by equations of the form
 $hc^2 = \alpha_i < 0$ ($1 \leq i \leq 4$),*
- (2) *the bifurcation set Σ consists of Σ' and the coordinate axes $h = 0$ and $c = 0$.*

◁ If U is the potential energy in the three-body problem, then the effective potential U_c is clearly equal to $U + c^2/2I$, where I is the moment of inertia of the points with respect to their barycentre (cf. § 1.1). In a relative equilibrium, dU is proportional to dI and therefore the three points form a central configuration (see § 2.3.1). For a fixed value $c \neq 0$ there are exactly five such configurations: three collinear and two triangular. In the latter case the triangle is necessarily equilateral and these two triangular configurations differ only in the order of the gravitating points. Let ω be the constant angular velocity of rotation of a central configuration. Then, obviously, $|c| = I|\omega|$, $T = I\omega^2/2$, and

$$h = T + U = \frac{c^2}{2I} + U.$$

Since all the configurations of this type are similar, we can assume that $I = \alpha^2 I_0$ and $U = \alpha^{-1} U_0$. The similarity ratio α can be found from the equality $2T = U$, which is a consequence of Lagrange's identity $\dot{I} = 2T - U$. The coefficient α is equal to $c^2/I_0 U_0$ and therefore $hc^2 = \alpha_s < 0$ in a relative equilibrium. By part 2) of Proposition 3.10 the bifurcation set Σ includes the curves defined by the equations $hc^2 = \alpha_s$ ($1 \leq s \leq 5$). Among the five numbers $\alpha_1, \dots, \alpha_5$ at least two are equal (they correspond to the triangular solutions of Lagrange). The bifurcation set obviously includes also the straight lines $h = 0$, $c = 0$ (as in Kepler's problem). As shown by Smale, the set Σ does not contain any other points (see [47]). ▷

Smale's paper [47] contains information about the topological structure of the integral manifolds in various connected components of the set $\mathbb{R}^2 \setminus \Sigma$.

3.3.4 Bifurcation Sets and Integral Manifolds in the Problem of Rotation of a Heavy Rigid Body with a Fixed Point

Let $A_1 \geq A_2 \geq A_3$ be the principal moments of inertia of a rigid body, and let x_1, x_2, x_3 be the coordinates of the centre of mass relative to the principal axes. If ω is the angular velocity of the body, and \mathbf{e} the unit vertical vector (both given in the moving space), then $H = \langle A\omega, \omega \rangle / 2 + \varepsilon \langle \mathbf{x}, \mathbf{e} \rangle$ and $J = \langle A\omega, \mathbf{e} \rangle$, where $A = \text{diag}(A_1, A_2, A_3)$. Our task is to describe the bifurcation diagram Σ in the plane \mathbb{R}^2 with coordinates h, c and the topological structure of the reduced integral manifolds $\tilde{I}_{h,c}$. It is useful to consider first the special degenerate case where $\varepsilon = 0$ (the Euler problem). The relative equilibria are the critical points of the effective potential $\tilde{U}_c = c^2/2 \langle A\mathbf{e}, \mathbf{e} \rangle$ on the unit sphere $\langle \mathbf{e}, \mathbf{e} \rangle = 1$. If the body is asymmetric ($A_1 > A_2 > A_3$), then there are exactly six such points: $(\pm 1, 0, 0)$, $(0, \pm 1, 0)$, $(0, 0, \pm 1)$. These points correspond to the uniform rotations of the rigid body around the principal axes. Since $\omega = c\mathbf{e} / \langle A\mathbf{e}, \mathbf{e} \rangle$ in a relative equilibrium of the body (see Example 3.15), the energy h and the angular momentum c are connected by one of the relations $h = c^2/2A_s$ ($1 \leq s \leq 3$). Since the configuration space of the rigid body – the group $SO(3)$ – is compact, the bifurcation set Σ is the union of the three parabolas (Fig. 3.4).

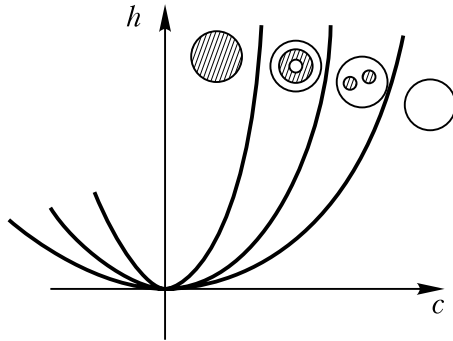

Fig. 3.4. Bifurcation diagram of the Euler problem

In the case of dynamical symmetry the number of parabolas diminishes; if $A_1 = A_2 = A_3 = A$, then Σ consists of the single parabola $h = c^2/2A$. Let $B_{h,c} = \{\tilde{U}_c \leq h\}$ be the region of possible motion on the Poisson sphere. The classification of the regions $B_{h,c}$ and the reduced integral manifolds $\tilde{I}_{h,c}$ in the Euler problem are given by the following.

Proposition 3.12. *Suppose that $A_1 > A_2 > A_3$. Then*

- 1) if $h < c^2/2A_1$, then $B_{h,c} = \emptyset$ and $\tilde{I}_{h,c} = \emptyset$;
- 2) if $c^2/2A_1 < h < c^2/2A_2$, then $B_{h,c} = D^2 \cup D^2$ and $\tilde{I}_{h,c} = 2S^3$;

- 3) if $c^2/2A_2 < h < c^2/2A_3$, then $B_{h,c} = D^1 \times S^1$ and $\tilde{I}_{h,c} = S^2 \times S^1$;
- 4) if $c^2/2A_3 < h$, then $B_{h,c} = S^2$ and $\tilde{I}_{h,c} = SO(3)$.

The description of the topological structure of the reduced integral manifolds is based on the following observation: $\tilde{I}_{h,c}$ is diffeomorphic to the fibre bundle with base space $B_{h,c}$ and fibre S^1 such that the fibre over each point of the boundary $\partial B_{h,c}$ is identified with the point.

In the general case, where the centre of mass does not coincide with the point of suspension, the problem of a complete description of the bifurcation sets and integral manifolds is considerably more difficult. This problem was studied in detail in the papers of Katok [307], Tatarinov [579], and Kuz'mina [363].

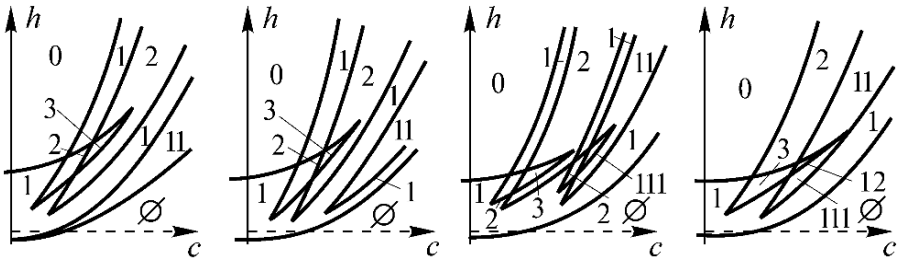

Fig. 3.5.

As an example we give a series of pictures in [579] which shows the mechanism of the transformation of the bifurcation diagram when the centre of mass passes from a generic position in the plane $x_3 = 0$ to the axis $x_1 = x_2 = 0$. The numbers in these pictures indicate the “multivalued genus” of the regions of possible motion on the Poisson sphere. We say that a connected region $B_{h,c}$ has genus l if $B_{h,c}$ is diffeomorphic to the sphere S^2 from which l non-intersecting open discs are removed. If a region of possible motion is disconnected, then we assign to it the multivalued genus l_1, l_2, \dots , where the l_s are the genera of its connected components. (Since in the situation under consideration the numbers l_s are at most three, no confusion arises.) The topology of the integral manifolds is uniquely determined by the structure of the regions of possible motion (their genera). The topological structure of maps defined by integrals (for example, momentum maps or energy–momentum maps) is described by the complex whose points are the connected components of the level manifolds of the integrals. For example, for a Hamiltonian system with one degree of freedom whose phase space is simply connected (a disc or a sphere S^2) this complex turns out to be a tree (the level lines of a function with two maxima and one saddle, like the mountain El’brus, form a complex homeomorphic to the letter Y). For a phase space that is a surface of genus g

the resulting graph has g independent cycles (the simplest function on a torus gives rise to a complex homeomorphic to the letter A).

If the number of independent integrals r is greater than 1, then the complex of connected components is no longer a graph but an r -dimensional “surface” with singularities.

The topological invariants of the components are “functions” on this complex. The study of the topological structure of integrable problems should be accompanied by the description of these complexes and “functions” on them. But this has not been done even for the simplest classical integrable systems, notwithstanding hundreds of publications (often erroneous) describing their topological structure.

Variational Principles and Methods

One of the fundamental objects of classical mechanics is a Lagrangian system – a pair (M, L) , where M is a smooth manifold (the configuration space of the mechanical system), and L a smooth function on the tangent bundle TM (the Lagrange function or Lagrangian). One can also consider a more general case where L depends explicitly on time t . Motions of the Lagrangian system are the smooth paths $x: [t_1, t_2] \rightarrow M$ that are critical points of the functional (action according to Hamilton)

$$F = \int_{t_1}^{t_2} L dt$$

in the class of paths with fixed ends (Hamilton's principle).

In the simplest and most prevalent case of “natural” mechanical systems the Lagrangian is given by the function $\langle \dot{x}, \dot{x} \rangle / 2 - U(x)$, where $\langle \cdot, \cdot \rangle$ is a Riemannian metric on M (double the kinetic energy) and $U: M \rightarrow \mathbb{R}$ is the potential energy of the force field. According to the celebrated Maupertuis principle of least action, the trajectories of motions with total energy $\langle \dot{x}, \dot{x} \rangle / 2 + U(x) = h$ are the geodesics of the Jacobi metric $ds = \sqrt{2(h - U)} \langle \dot{x}, \dot{x} \rangle$. By the energy integral, motion takes place in the domain where the function $h - U$ is non-negative. If $\sup_M(U) < h$, then the description of motions of the natural system reduces to a problem of Riemannian geometry. From the viewpoint of oscillation theory the opposite case is more interesting, where the equality $U = h$ holds at some points on M . The Jacobi metric degenerates at these points. Of considerable interest are the problems of existence of closed trajectories with ends on the boundary $\{x \in M: h - U = 0\}$. The relevant results are expounded in §§ 4.1–4.2.

If the summand $\omega(\dot{x})$ is added to the Lagrangian $L = \langle \dot{x}, \dot{x} \rangle / 2 - U(x)$, where ω is some 1-form on M , then we obtain the next in complexity class of mechanical systems. This class is studied in § 4.3. Recall that $d\omega$ is called the 2-form of gyroscopic forces (see Ch. 3). Gyroscopic forces appear in the

passage to a rotating frame of reference, in the Routh reduction of the number of degrees of freedom of a system with symmetries, and in the description of motion of charged bodies in a magnetic field. For various reasons the presence of gyroscopic forces considerably complicates the problem of periodic motions. Problems of existence of periodic trajectories are considered in § 4.3 also from the viewpoint of the theory of dynamical systems.

In § 4.4 Hamilton's principle is used to establish the existence of asymptotic motions. The results of this section are applied for studying the stability of periodic or almost periodic oscillation regimes.

We did not set ourselves an aim to give an exhaustive survey of papers related to applications of variational calculus to classical mechanics on the whole. We confined ourselves to the Lagrangian aspect of mechanics, leaving aside the variational principle of the theory of Hamiltonian systems

$$\delta \int_{t_1}^{t_2} (y \cdot \dot{x} - H) dt = 0.$$

In this variational problem of Hamilton, modified by Poincaré, symplectic coordinates x, y ("momentum coordinates") are regarded as independent variables. The "action" functional defined on curves in the phase space is unbounded below (and above) and therefore the method of gradient descent of the Morse theory is not effective in the problem of periodic trajectories in this situation. Here other methods are applied, an idea of which can be given by the papers [196, 223]. We also mention the "non-traditional" Percival's principle [497] justified in Mather's paper [412] (see also § 6.3.8). This principle is intended for finding the invariant tori of a nearly integrable Hamiltonian system.

4.1 Geometry of Regions of Possible Motion

4.1.1 Principle of Stationary Abbreviated Action

Let M be a connected manifold, and (M, L) a Lagrangian system with Lagrangian $L = L_2 + L_1 + L_0$, where each L_s is a smooth function on TM that is homogeneous in the velocities of homogeneity degree s . We assume that the form L_2 is positive definite, so that L_2 – the kinetic energy of the system – defines a Riemannian metric on M . The function $L_0: M \rightarrow \mathbb{R}$ can be identified with the force function $V: M \rightarrow \mathbb{R}$ (so that $V = -U$).

Lagrange's equation $[L] = 0$ has the energy integral $H = L_2 - L_0$. For a fixed value $H = h$ motion can take place only in the domain

$$B_h = \{x \in M: U \leq h\}$$

called the *region of possible motion*. For $h > \bar{h} = \sup_M U$ the set B_h coincides with the entire configuration space M . If $\inf U < h < \bar{h}$, then the boundary

∂B_h is non-empty. In a typical case, where h is a regular value of the function $H: TM \rightarrow \mathbb{R}$, the region B_h is a smooth manifold with smooth boundary $\partial B_h = \Sigma_h$; the dimension of Σ_h is smaller by one than the dimension of M .

For simplicity, let $h = 0$ (if $h \neq 0$, then we can replace L by $L+h$). Suppose that $B \setminus \Sigma \neq \emptyset$ (where $B = B_0$ and $\Sigma = \Sigma_0$). In what follows we assume that B is *connected* (since we can always confine our considerations to motions in one of the connected components of the region B).

Definition 4.1. The functional

$$F^* = \int_{t_1}^{t_2} (2\sqrt{L_0 L_2} + L_1) dt = F - \int_{t_1}^{t_2} (\sqrt{L_2} - \sqrt{L_0})^2 dt$$

defined on the smooth curves $x: [t_1, t_2] \rightarrow B$ is called the *abbreviated action* or *Maupertuis action*.

The integrand in F^* is a homogeneous function of the velocity of degree 1. Consequently, the value of the abbreviated action F^* is independent of the parametrization of the integration path.

Theorem 4.1. *A smooth path $x: [t_1, t_2] \rightarrow B \setminus \Sigma$ such that $H(\dot{x}(t)) = 0$ for all $t_1 \leq t \leq t_2$ is a solution of Lagrange's equation $[L] = 0$ if and only if this path is a critical point of the functional F^* .¹*

◁ Suppose that $[L]_{x(t)} = 0$ and $L_2(\dot{x}(t)) \equiv L_0(x(t))$. Then

$$\delta F^* = \delta F - \int_{t_1}^{t_2} (\sqrt{L_2} - \sqrt{L_0}) \delta(\sqrt{L_2} - \sqrt{L_0}) dt = 0. \quad (4.1)$$

Conversely, suppose that a smooth path $x: [s_1, s_2] \rightarrow B \setminus \Sigma$ is a stationary point of the functional F^* . We set

$$t = \int_{s_0}^s \frac{\sqrt{L_2}}{\sqrt{L_0}} d\tau.$$

Then the smooth path $x(s(t)): [t_1, t_2] \rightarrow B \setminus \Sigma$ obviously satisfies the equation $L_2 = L_0$. If $\delta F^* = 0$, then formula (4.1) implies that $\delta F = 0$. The theorem is proved. ▷

¹ Historically “Maupertuis’s principle” (Theorem 4.1) preceded the simpler Hamilton’s principle of stationary actions. “The actual content of this “principle” was not quite clear to Maupertuis. The precise formulation given in the text is due to Jacobi and to his predecessors, Euler and Lagrange” (Wintner [52], p. 124). In fact, this principle does not at all require naturality, although it is this *special* case that Jacobi was making more precise.

We define a Riemannian metric (\cdot, \cdot) inside the region B by setting

$$(\dot{x}, \dot{x}) = 4L_0(x)L_2(\dot{x}), \quad \dot{x} \in TB.$$

This metric is called the *Jacobi metric*. For natural systems, where the form of gyroscopic forces is $L_1 \equiv 0$, Theorem 4.1 means that in the domain $B \setminus \Sigma$ the motions with zero total energy coincide with the geodesics of the Jacobi metric. In the original notation for the Jacobi metric we have the formula

$$(\cdot, \cdot) = 2(h - U)\langle \cdot, \cdot \rangle.$$

Thus, the metrics (\cdot, \cdot) and $\langle \cdot, \cdot \rangle$ are conformally equivalent inside the region of possible motion.

If $h > \bar{h}$, then the region B coincides with M , and $(B, (\cdot, \cdot))$ is an ordinary Riemannian manifold. However, if the boundary Σ of the region B is non-empty, then the Jacobi metric has a singularity: the lengths of the curves lying on Σ are equal to zero.

Natural systems are “reversible”: together with a solution $x(t)$, the equations of motion have the solution $x(-t)$. This simple remark and the uniqueness theorem imply the following.

Proposition 4.1. *Suppose that $x: (-\varepsilon, \varepsilon) \rightarrow B$ is a motion of a natural system and $x(0) \in \Sigma$. Then $x(t) = x(-t)$ for all $-\varepsilon < t < \varepsilon$.*

Of course, Proposition 4.1 is not valid in the general, non-reversible case.

Example 4.1. Consider the Lagrangian system $(\mathbb{R}^2\{x, y\}, L)$ with the Lagrangian $L = (\dot{x}^2 + \dot{y}^2)/2 + \omega(x\dot{y} - y\dot{x}) + V(x, y)$. The equations of motion

$$\ddot{x} = 2\omega\dot{y} + V'_x, \quad \ddot{y} = -2\omega\dot{x} + V'_y \tag{4.2}$$

have the same form as the equations of the restricted three-body problem. Suppose that $(0, 0) \in \Sigma$ and the x -axis is directed along the normal to Σ inward the region B . Let $(x, y): (-\varepsilon, \varepsilon) \rightarrow B$ be a solution of equations (4.2) such that $x(0) = y(0) = 0$. Then $\dot{x}(0) = \dot{y}(0) = 0$. Suppose that the point $x = y = 0$ is a regular point of the force function V . Since $V'_y(0) = 0$, we have

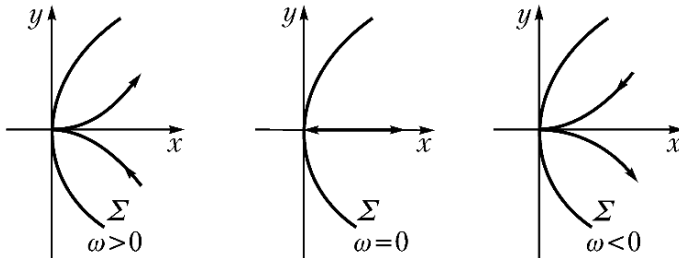

Fig. 4.1.

$V'_x(0) > 0$ (taking into account the chosen direction of the x -axis). It follows from (4.2) that $\ddot{x}(0) = \alpha > 0$, $\ddot{y}(0) = 0$, and $\ddot{y}'(0) = -2\omega\alpha$. Consequently, by Taylor's formula we have the expansions

$$x(t) = \frac{\alpha t^2}{2} + o(t^2), \quad y(t) = -\frac{2\omega\alpha t^3}{3} + o(t^3).$$

Thus, near the cusp point $x = y = 0$ both branches of the trajectory have the form of a semicubic parabola (see Fig. 4.1). This conclusion is of course valid also for a system of the most general form. △

4.1.2 Geometry of a Neighbourhood of the Boundary

Suppose that the boundary Σ of the region B is compact and does not contain equilibrium positions of our natural system ($dV|_{\Sigma} \neq 0$). For $q \in \Sigma$ and $t \geq 0$ we denote by $x(q, t)$ the solution of the equations of motion with the initial conditions

$$x(q, 0) = q, \quad \left. \frac{\partial}{\partial t} \right|_{t=0} x = 0. \tag{4.3}$$

Our task is to study the smooth map $x: \Sigma \times [0, \varepsilon) \rightarrow B$.²

Since the function $V: M \rightarrow \mathbb{R}$ has no critical points on Σ , we have

$$\left. \frac{\partial^2}{\partial t^2} \right|_{t=0} V(x(q, t)) = -2L_2^*(V'(q)) < 0, \tag{4.4}$$

where $L_2^*: T^*M \rightarrow \mathbb{R}$ is the dual function of the kinetic energy function $L_2: TM \rightarrow \mathbb{R}$ (in the sense of the Legendre transformation) and $V' = \partial V / \partial q$ is the covector field. Consequently, the map $x: \Sigma \times [0, \varepsilon) \rightarrow B$ maps a small neighbourhood of $\Sigma \times \{0\}$ homeomorphically onto some neighbourhood of the manifold Σ in B , and the inverse map is smooth outside Σ .

Let $s(q, t)$ denote the arc length in the Jacobi metric along the geodesic $t \mapsto x(q, t)$:

$$s(q, t) = \int_0^t \left| \frac{\partial x(q, t)}{\partial t} \right| dt = 2 \int_0^t V(x(q, t)) dt.$$

It follows from (4.3) and (4.4) that for $t = 0$ we have

$$s = s'_t = s''_{tt} = 0, \quad s'''_{ttt} > 0.$$

By the implicit function theorem the equation $r^3 = s(q, t)$ can be resolved with respect to t for sufficiently small values of r ; the function $t(q, r)$ is smooth and at $r = 0$ we have

$$t = 0, \quad t'_r > 0. \tag{4.5}$$

² If the region B is compact, then the map x is defined on $\Sigma \times [0, \infty)$.

For all $q \in \Sigma$ and small $r \geq 0$ the smooth map $(q, r) \mapsto (q, t(q, r))$ is defined. Since at $r = 0$ its Jacobian is equal to $t'_r > 0$ and Σ is compact, this map is a diffeomorphism in a sufficiently small neighbourhood of the set $\Sigma \times \{0\}$. For small $\varepsilon > 0$ we can define a map $f: \Sigma \times [0, \varepsilon] \rightarrow B$ by the formula $f(q, s) = x(q, t(q, s^{1/3}))$; then f maps $\Sigma \times [0, \varepsilon]$ homeomorphically onto some neighbourhood of the manifold Σ in B , and the restriction of f to $\Sigma \times (0, \varepsilon)$ is a diffeomorphism.

For all $0 < s < \varepsilon$ we set $W_s = f(\Sigma \times [0, s])$, $B_s = B \setminus f(\Sigma \times [0, s])$, and $\Sigma_s = f(\Sigma \times \{s\})$.

Lemma 4.1. *The sets W_s , B_s , and Σ_s are smooth submanifolds of B , which are diffeomorphic to $\Sigma \times [0, 1]$, B , and Σ , respectively.*

Indeed, the map $(q, r) \mapsto f(q, r^3)$ is smooth, and by (4.3)–(4.5) at $r = 0$ we have

$$f = q, \quad f'_r = 0, \quad V''_{rr}(f(q, r^3)) < 0.$$

Proposition 4.2. *For small values of ε the set W_ε has the following properties:*

- 1) *the geodesics of the Jacobi metric starting on Σ intersect the hypersurface $\Sigma_s \subset W_\varepsilon$ ($0 < s \leq \varepsilon$) at right angle;*
- 2) *for every point $z \in W_\varepsilon$ there exists a unique geodesic γ_z starting on Σ and passing through z ;*
- 3) *the geodesic γ_z is the shortest piecewise-smooth curve connecting the point z with the set Σ ;*
- 4) *there exists $\delta > 0$ such that each geodesic of the Jacobi metric of length less than δ connecting two points in W_ε is entirely contained in W_ε .*

Conclusions 1) and 4) are analogues of the well-known assertions of Gauss and Whitehead in Riemannian geometry. The proof can be found in [129].

This proposition implies, in particular, that Σ_s ($s < \varepsilon$) coincides with the set of points in B at the distance s from the boundary. A similar geometric interpretation can be given for the sets W_s and B_s .

4.1.3 Riemannian Geometry of Regions of Possible Motion with Boundary

For $a, b \in B$ let Ω_{ab} denote the set of all piecewise-smooth paths $\gamma: [0, 1] \rightarrow B$ with initial point a and endpoint b . We define a function $d: B \times B \rightarrow \mathbb{R}$ by the formula $d(a, b) = \inf\{l(\gamma): \gamma \in \Omega_{ab}\}$, where $l(\gamma)$ is the length of a path γ in the Jacobi metric. The non-negative function d defines a deviation on the set B , since

- 1) $d(a, a) = 0$ for all $a \in B$;
- 2) $d(a, b) = d(b, a)$ for all $a, b \in B$;

3) $d(a, b) + d(b, c) \geq d(a, c)$ for all $a, b, c \in B$.

Recall that a *deviation* d on the set B is a non-negative function $B \times B \rightarrow \mathbb{R}$ satisfying conditions 1)–3) listed above.

Note that the deviation d is not a distance on B , since $d(a, b) = 0$ for any points a, b in the same connected component of the manifold Σ – the boundary of the region B . However, if $a \notin \Sigma$, then the equality $d(a, b) = 0$ implies $a = b$. Hence d is a distance inside the region B and therefore $(B \setminus \Sigma, \langle \cdot, \cdot \rangle)$ is a (non-complete) Riemannian manifold.

We define the distance from a point $c \in B$ to the manifold Σ as the number

$$\partial(c) = \inf_{x \in \Sigma} d(c, x).$$

If the boundary is connected, then $\partial(c) = d(c, a)$ for all $a \in \Sigma$. The distance is $\partial(c) = 0$ if and only if $c \in \Sigma$. Note that the functions d and ∂ are continuous on $B \times B$ and B , respectively.

Proposition 4.3. *Suppose that the set B is compact.*

- a) *If Σ is connected, then $d(a, b) \leq \partial(a) + \partial(b)$, for all $a, b \in B$.*
- b) *If $d(a, b) < \partial(a) + \partial(b)$, then the points a, b can be connected by a geodesic of the Jacobi metric of length $d(a, b)$ entirely contained in $B \setminus \Sigma$.*

This assertion can be easily proved by the standard methods of Riemannian geometry.

Theorem 4.2 ([323]). *If B is compact, then every point $a \in B$ can be connected with some point of Σ by a geodesic of length $\partial(a)$.*

Let $x(q, t) \in B$ be the image of a point (q, t) under the smooth map $x: \Sigma \times [0, \infty) \rightarrow B$ (see § 4.1.2). Since the equations of motion are reversible, we have the following.

Corollary 4.1. $\bigcup_{t \geq 0} \bigcup_{q \in \Sigma} x(q, t) = B$.

\triangleleft *Proof of Theorem 4.2.* Let $\gamma': [0, 1/2] \rightarrow B$ be a shortest geodesic connecting the point $\gamma'(0) = a$ with the hypersurface Σ_ε . Such a curve exists and it is orthogonal to Σ_ε at the point $\gamma'(1/2)$. By Proposition 4.3 there exists a geodesic $\gamma'': [1/2, 1] \rightarrow B$ of length ε connecting the point $\gamma''(1/2) = \gamma'(1/2)$ with the boundary Σ . The curve $\gamma: [0, 1] \rightarrow B$ that coincides with γ' and γ'' on the intervals $[0, 1/2]$ and $[1/2, 1]$, respectively, is obviously a smooth geodesic of length $\partial(a)$ such that $\gamma(0) = a$ and $\gamma(1) \in \Sigma$. \triangleright

Theorem 4.2 can be regarded as an analogue of the Hopf–Rinow theorem in Riemannian geometry (see [423]). Note that in contrast to the Riemannian case, here not every two points can be connected by a geodesic of the Jacobi metric, even for compact B .

Example 4.2. Consider the oscillations with total energy $h = 1/2$ of the planar harmonic oscillator described by the equations $\ddot{x} = -x$, $\ddot{y} = -y$. In this problem, B is the unit disc $x^2 + y^2 \leq 1$. One can show that the set of points of the unit disc that the motion can reach from a point $(x, y) = (a, 0)$ with the initial velocity $|v| = \sqrt{1 - a^2}$ is given by the inequality $x^2 + y^2 / (1 - a^2) \leq 1$ (see Fig. 4.2). As $a \rightarrow 0$ (respectively, $a \rightarrow 1$), this “attainability set” converges to the whole region B (respectively, to the segment $y = 0$, $-1 \leq x \leq 1$).

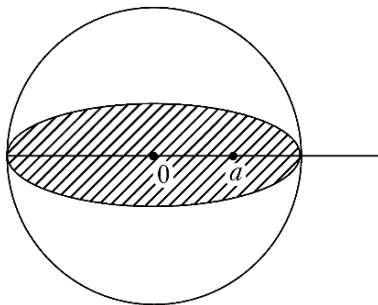

Fig. 4.2.

△

Theorem 4.2 is not valid in the non-reversible case.

Example 4.3. Consider the planar harmonic oscillator under the action of additional gyroscopic forces:

$$\ddot{x} = -2\omega\dot{y} - x, \quad \ddot{y} = 2\omega\dot{x} - y. \quad (4.6)$$

Such equations describe, in particular, small oscillations of the Foucault pendulum (see [10]). In this problem, B is again the disc $x^2 + y^2 \leq 1$.

Let B^ω be the set of points in B that can be reached from the boundary Σ moving along the trajectories of system (4.6). In the polar coordinates r , φ equations (4.6) take the form

$$\ddot{r} = r(\dot{\varphi}(\dot{\varphi} - 2\omega) - 1), \quad (r^2\dot{\varphi})' = (\omega r^2)'$$

The second equation can be integrated: $r^2\dot{\varphi} = \omega r^2 + c$. Since $\dot{r} = \dot{\varphi} = 0$ and $r = 1$ at $t = 0$, we have $c = -\omega$. On substituting $\dot{\varphi} = (1 - r^{-2})\omega$ into the first equation we obtain the system with one degree of freedom

$$\ddot{r} = -(1 + \omega^2)r + \frac{\omega^2}{r^3}.$$

The energy integral

$$\frac{\dot{r}^2}{2} + (1 + \omega^2)\frac{r^2}{2} + \frac{\omega^2}{2r^2} = \frac{1}{2} + \omega^2$$

implies that the set B^ω is given by the inequalities

$$\frac{\omega^2}{1 + \omega^2} \leq r^2 \leq 1.$$

Consequently, for $\omega \neq 0$ the domain B^ω does not coincide with B ; if $\omega \rightarrow 0$, then B^ω converges to B , and as $\omega \rightarrow \infty$ the domain B^ω degenerates into the boundary $\Sigma = \{x^2 + y^2 = 1\}$. The trajectories of system (4.6) starting on Σ are shown in Fig. 4.3. For almost all values of ω they fill the domain B^ω everywhere densely. Note that if a trajectory of system (4.6) passes through the origin of reference, then $c = 0$ and therefore $\dot{\varphi} \equiv \omega$. In this case the point performs harmonic oscillations with frequency $\sqrt{1 + \omega^2} > 1$ along the segment of length $2/\sqrt{1 + \omega^2} < 2$ passing through the origin and uniformly rotating with constant angular velocity ω . The existence of such motions is a characteristic property of the Foucault pendulum.

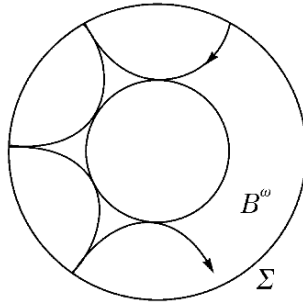

Fig. 4.3.

△

In the general non-reversible case we denote by B^+ the closed set of points in B where the inequality $4L_0L_2 \geq L_1^2$ holds. If the degenerate case is excluded, where the linear function L_1 vanishes at some points on Σ , then $B^+ \subset B \setminus \Sigma$. The integrand in the abbreviated action functional F^* is positive definite inside the domain B^+ . This property holds simultaneously for the mechanical systems with the Lagrangians $L_\pm = L_2 \pm L_1 + L_0$. Note that if $x(t)$ is a solution of Lagrange's equation $[L_+] = 0$, then $x(-t)$ is a solution of the equation $[L_-] = 0$, and conversely.

It may happen that B^+ is empty. In this case we can proceed as follows. Let $L_1 = a(x) \cdot \dot{x}$ and let $x_0 \in B \setminus \Sigma$. We replace locally the form L_1 by $L_1 - \widehat{L}_1$, where $\widehat{L}_1 = a(x_0) \cdot \dot{x}$. Since the form \widehat{L}_1 is closed, Lagrange's equation $[L] = 0$ does not change. For the new Lagrange function the inequality $4L_0L_2 > L_1^2$ holds in a small neighbourhood of the point x_0 , since $L_1 \equiv 0$ for $x = x_0$. This remark allows us to vary the form and location of the domain B^+ .

We diminish the domain B^+ by removing from it the ε -neighbourhood (for example, in the Jacobi metric) of its boundary ∂B^+ and denote the remaining set by B_ε^+ .

Proposition 4.4. *Suppose that B is compact and the set B_ε^+ is non-empty for some $\varepsilon > 0$. Then*

- 1) *for every point $a \in B_\varepsilon^+$ there exists a solution $x: [0, \tau] \rightarrow B_\varepsilon^+$ of Lagrange's equation $[L] = 0$ such that $x(0) = a$ and $x(\tau) \in \partial B_\varepsilon^+$,*
- 2) *for every point $a \in B_\varepsilon^+$ there exists a solution $y: [0, \tau] \rightarrow B_\varepsilon^+$ such that $y(0) \in \partial B_\varepsilon^+$ and $y(\tau) = a$.*

\triangleleft The curves $x(t)$ and $y(-t)$ give the minima of the action functionals F^* corresponding to the Lagrangians L_+ and L_- , respectively, on the set of piecewise-smooth curves connecting the point a with the boundary of B_ε^+ . \triangleright

Remark 4.1. In contrast to Theorem 4.2, in Proposition 4.4 one cannot set the constant ε to be equal to zero (even in the case where $B^+ \subset B \setminus \Sigma$).

Example 4.4. The motion of an asteroid in the restricted three-body problem is described by equation (4.2), in which we must set $\omega = 1$ and

$$V = \frac{x^2 + y^2}{2} + \frac{1 - \mu}{\rho_1} + \frac{\mu}{\rho_2};$$

$$\rho_1 = \sqrt{(x + \mu)^2 + y^2}, \quad \rho_2 = \sqrt{(x - 1 + \mu)^2 + y^2}.$$

In this problem the Sun and Jupiter with masses $1 - \mu$ and μ revolve with unit angular velocity in circular orbits of radii μ and $1 - \mu$ around their common centre of mass, while the asteroid, a body of negligibly small mass, moves in the ecliptic plane experiencing the gravitation of the Sun and Jupiter (Fig. 4.4); see the details in Ch. 2. The region B (called the Hill region)

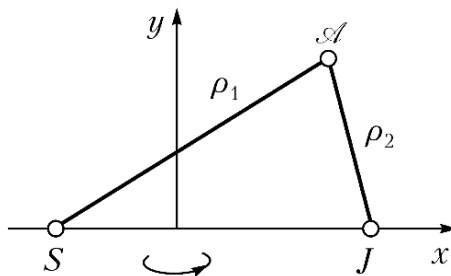

Fig. 4.4.

is defined by the inequality $V \geq -h$. If L_1 has the “standard” form $\dot{x}y - y\dot{x}$, then B^+ coincides with the set

$$\left\{ \frac{1 - \mu}{\rho_1} + \frac{\mu}{\rho_2} \geq -h \right\},$$

which is the region of possible motion in the problem of two fixed centres (the stationary Sun and Jupiter attract the asteroid according to the law of universal gravitation). \triangle

4.2 Periodic Trajectories of Natural Mechanical Systems

4.2.1 Rotations and Librations

A solution $x: \mathbb{R} \rightarrow M$ of Lagrange's equations $[L] = 0$ is periodic if for some $\tau > 0$ we have $x(t + \tau) = x(t)$ for all $t \in \mathbb{R}$. The trajectory of a periodic solution is always closed. We are interested in the problem of the existence of closed trajectories for a fixed value of the total energy h . We assume that h is a regular value (to exclude trivial periodic trajectories – equilibrium positions).

Proposition 4.5. *The closed trajectory γ of a periodic solution $x: \mathbb{R} \rightarrow B$ of a natural system with zero value of total energy either*

- 1) *does not intersect the boundary Σ of the region of possible motion B , or*
- 2) *has exactly two common points with Σ .*

Corresponding to each trajectory of the first type there are two distinct (up to a shift in t) periodic solutions (revolutions along γ in opposite directions), and to a trajectory of the second type there corresponds a unique periodic solution (oscillating motion between the endpoints of γ). We call periodic motions of the first type *rotations*, and of the second type, *librations*. Proposition 4.1 implies that if the trajectory of a solution $x: \mathbb{R} \rightarrow B$ has two common points with the boundary Σ of the region B , then there are no other common points and the solution $x(\cdot)$ is a libration.

If $\Sigma = \emptyset$, then the question of the existence of periodic rotations reduces to the question of the existence of closed geodesics of the Riemannian manifold $(M, (\cdot, \cdot))$. This classical problem of Riemannian geometry is fairly well studied (at least in the case of compact M). If M is not simply connected, then, as shown by Hadamard in 1898, every closed curve that is not homotopic to zero can be deformed into a closed geodesic of minimum length in its free homotopy class. This remark allows one to estimate from below the number of distinct closed geodesics on a multiply connected manifold.

The problem of the existence of periodic geodesics in the case of simply connected M is much more difficult. In 1905 Poincaré established the existence of such curves on a convex two-dimensional sphere.³ Later this result

³ Poincaré suggested two approaches for solving this problem. The first is based on the principle of analytic continuation of periodic trajectories (see also [68]). The second approach is purely variational: the curve of minimum length is sought among the closed non-self-intersecting curves dividing the sphere into two halves with equal total curvatures; this curve is the required closed geodesic.

was extended by Birkhoff to the case of an arbitrary multidimensional Riemann sphere. Lyusternik and Shnirel'man (1929) established the existence of three non-self-intersecting closed geodesics on a two-dimensional sphere. (Refinements of the procedure of constructing the length-reducing deformation in the space of non-self-intersecting contours are contained, for example, in [98, 266, 576]). Under certain additional restrictions an analogous result is valid in the multidimensional case: if the Gaussian curvature K of a Riemann sphere S^n (at all points and in all two-dimensional directions) satisfies the inequalities $K_0/4 < K \leq K_0$ for some $K_0 > 0$, then on S^n there exist n non-self-intersecting closed geodesics (Klingenberg). The existence of a closed geodesic on every compact manifold was established by Lyusternik and Fet (1951). For certain simply connected manifolds it was even possible to prove the existence of infinitely many distinct closed geodesics (Gromoll and Meyer).

At present it is not clear whether this result is valid in the general case of a simply connected manifold. For the classical case of a two-dimensional sphere the affirmative result was recently obtained by Bangert [99] (see also [282]) using a theorem of Franks. A survey of the current state of these problems can be found in Klingenberg's book [315] (although it contains a number of inaccuracies).

In the case of non-empty Σ the situation with the existence of periodic trajectories looks different. A good idea of this case is given by the following example.

Example 4.5. Consider the “polyharmonic” oscillator described by the equations $\ddot{x}_s + \omega_s^2 x_s = 0$ ($1 \leq s \leq n$) with rationally independent frequencies $\omega_1, \dots, \omega_n$. The region of possible motion B with total energy h is the ellipsoid $\sum \omega_s^2 x_s^2 \leq 2h$. For every $h > 0$ the equations of motion have exactly n periodic oscillations, which are librations whose trajectories coincide with the principal axes of this ellipsoid. It is worth mentioning the absence of rotations and the finiteness of the number of periodic trajectories for a fixed value of the total energy. If the frequencies $\omega_1, \dots, \omega_n$ are rationally commensurable, then the number of librations can be greater. For example, in the case $n = 2$ if the ratio of frequencies ω_1/ω_2 is rational, then through each point of Σ there passes the trajectory of a librational periodic motion.

For the proof one must use the fact that if the ratio ω_1/ω_2 is rational, then all the trajectories are closed, and apply Proposition 4.5. We mention the special case where $\omega_1 = 1$ and $\omega_2 = n \in \mathbb{N}$. The librations of energy h are given by the formulae $x_1 = x_0^1 \cos t$, $x_2 = x_0^2 \cos nt$, where $x_0^1 = \sqrt{2h} \sin \alpha$, $x_0^2 = \sqrt{2h} (\cos \alpha)/n$, and α is an arbitrary constant. Let $2h = n^2 + 1$; then for some α the values of x_0^1 and x_0^2 are equal to 1 and the trajectory of the corresponding libration in the plane \mathbb{R}^2 with coordinates x_1, x_2 coincides with a part of the graph of Chebyshev's polynomial T_n . \triangle

4.2.2 Librations in Non-Simply-Connected Regions of Possible Motion

For any group π we denote by $r(\pi)$ the least possible number of generators of this group. Let B/Σ be the topological space obtained from B by contracting its boundary Σ to a point, and let $\pi(B/\Sigma)$ be its fundamental group.

Theorem 4.3. *Suppose that the region B is compact and there are no equilibrium positions on Σ . Then the number of distinct librations in the region B is at least $r(\pi(B/\Sigma))$.*

Remark 4.2. This number is at least the first Betti number of the quotient of the region B modulo Σ .

Corollary 4.2. *If Σ consists of n connected components, then the number of librations in the region B is at least $n - 1$. Moreover, for each connected component of the manifold Σ there exists a libration with an endpoint on this component, and the trajectories of these librations have no self-intersections (see Fig. 4.5).*

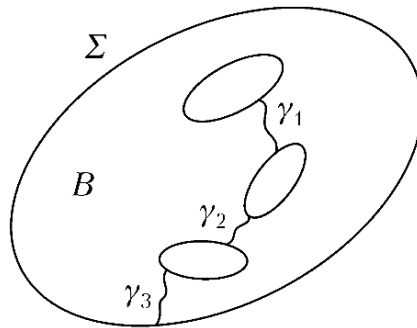

Fig. 4.5.

Indeed, in this case the group $\pi(B/\Sigma)$ contains a free group on $(n - 1)$ free generators. Theorem 4.3 was proved in [129]; it is analogous to the well-known Hadamard's theorem on minimal closed geodesics of a multiply connected Riemannian manifold.

We give the idea of the proof of Corollary 4.2. We can assume that B is a closed submanifold with boundary of some compact Riemannian manifold M whose metric on $B \setminus W_\varepsilon$ coincides with the Jacobi metric. Let $\Sigma_\varepsilon^1, \dots, \Sigma_\varepsilon^n$ be the connected components of the hypersurface Σ_ε and let d_{ij} ($i < j$) be the distances between Σ_ε^i and Σ_ε^j . We fix an index i and choose the minimum among the numbers d_{is} ($i \neq s$). This minimum is attained at a non-self-intersecting geodesic γ_i of length d_{is} entirely contained in $B \setminus W_\varepsilon$ and orthogonal

to Σ_ε at its endpoints. Using Proposition 4.2 we can extend the geodesic γ_i to a librational periodic solution (cf. the proof of Theorem 4.2). The number of such distinct “minimal” librations is clearly at least $n - 1$.

Example 4.6 ([129]). Consider the problem of the existence of librations for the planar n -link mathematical pendulum (see Fig. 4.6). Let l_1, \dots, l_n

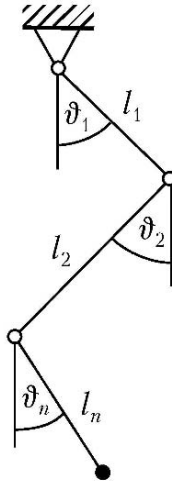

Fig. 4.6.

be the lengths of the links, which we number from the suspension point, let P_1, \dots, P_n be the weights of the corresponding material points, and $\vartheta_1, \dots, \vartheta_n$ the angles between the links and the vertical. The configuration space M is the n -dimensional torus $\mathbb{T}^n = \{\vartheta_1, \dots, \vartheta_n \bmod 2\pi\}$ and the potential energy has the form

$$U = - \sum_{i=1}^n a_i \cos \vartheta_i, \quad a_i = l_i \sum_{j=1}^n P_j.$$

The set of critical points of the function $U: \mathbb{T}^n \rightarrow \mathbb{R}$ is in a one-to-one correspondence with the set of all subsets of the set $A = \{1, 2, \dots, n\}$; the index of the critical point corresponding to a subset $I \subset A$ is equal to the number of elements in I , and the critical value is equal to

$$h_I = \sum_{i \in I} a_i - \sum_{i \notin I} a_i.$$

Let h be a regular value of the potential energy and suppose that $|h| < \sum_A a_i$. In this case the region $B \subset \mathbb{T}^n$ has non-empty boundary Σ . We set $\widehat{B} = \overline{\mathbb{T}^n \setminus B}$. Since $B/\Sigma = \mathbb{T}^n/\widehat{B}$, we have $\pi(B/\Sigma) = \pi(\mathbb{T}^n/\widehat{B})$. We set

$r = r(\pi(\mathbb{T}^n/\widehat{B}))$ and $\widehat{r} = r(\pi(\widehat{B}))$. Let $k \leq n$ be the number of critical points of the function $U: \mathbb{T}^n \rightarrow \mathbb{R}$ of index $n - 1$ in the set B . We claim that $r = k$.

Indeed, the space \mathbb{T}^n/\widehat{B} (respectively, \widehat{B}) is homotopy equivalent to a cell complex with k (respectively, $n - k$) one-dimensional cells. Hence $r \leq k$ and $\widehat{r} \leq n - k$. Since the groups $\pi(\widehat{B})$ and $\pi(\mathbb{T}^n/\widehat{B})$ generate the group $\pi(\mathbb{T}^n)$, we have $n \leq r + \widehat{r} \leq k + (n - k) = n$. Hence $r = k$. \triangle

Applying Theorem 4.3 we obtain the following assertion: if $h \neq h_I$ for any $I \subset \Lambda$ and $|h| < \sum_{\Lambda} a_i$, then the number of librations with total energy h is at least the number of indices i such that $a_1 + \dots + a_{i-1} + a_{i+1} + \dots + a_n < h$. Depending on the value of h , the lower estimate of the number of distinct librations varies from 0 to n . In § 4.2.4 we shall show how to improve this estimate using symmetry properties.

Theorem 4.3 on shortest librations admits the following refinement due to Bolotin.

Theorem 4.4. *Suppose that B is compact and there are no equilibrium positions on Σ . Then in the region B there exist at least $r(\pi(B/\Sigma))$ distinct unstable librations with real characteristic exponents.*

The proof of this assertion consists precisely in verifying that all the characteristic exponents of the shortest librational solutions, whose existence is guaranteed by Theorem 4.3, are real. See the definition of characteristic exponents in § 7.1.2 (their basic properties are also discussed there).

Example 4.7. Consider the motion of a material point in a central field with potential $U = r + r^{-1}$. For $h > 2$ the region of possible motion B is an annulus and through every point of the boundary there obviously passes the trajectory of a librational solution. All these librations are shortest ones; they are degenerate, since all their characteristic exponents are equal to zero. The instability of a libration can be easily derived from the area integral: $r^2\dot{\varphi} = \text{const}$. \triangle

In the general case the characteristic exponents are non-zero and therefore the shortest librations are (orbitally) unstable even in the linear approximation. Moreover, since these librations are hyperbolic periodic solutions, there exist families of trajectories that asymptotically approach the trajectories of shortest librations either as $t \rightarrow +\infty$ or as $t \rightarrow -\infty$.

Let $A(\gamma)$ denote the set of points in the region B through which there pass trajectories asymptotic to γ . The following example gives an idea about the shape and location of the set A .

Example 4.8 (Bolotin). Consider the Lagrangian system with configuration space $M = S^1\{x \bmod 2\pi\} \times \mathbb{R}\{y\}$ and Lagrangian

$$L = (\dot{x}^2 + \dot{y}^2)/2 + \cos x - y^2/2.$$

For $h > 1$ the region B is diffeomorphic to the annulus $|y| \leq \sqrt{2(h + \cos x)}$, and the curve $x \equiv \pi$, $y = \sqrt{2(h - 1)} \cos t$ is a shortest libration of energy h .

Lagrange's equations $[L] = 0$ have two first integrals $\dot{x}^2/2 - \cos x$ and $\dot{y}^2 + y^2$. Using these integrals one can easily show that $A = \{|y| \leq \sqrt{2(h-1)}\}$. Note that A does not coincide with B and the intersection $A \cap \Sigma$ consists of the endpoints of the trajectory of the shortest libration. \triangle

4.2.3 Librations in Simply Connected Domains and Seifert's Conjecture

The first general result on librations of natural systems is due to Seifert. He proved in [537] the existence of a libration in the case where the region B is diffeomorphic to the n -dimensional disc.

Theorem 4.5 (Bolotin). *If the region B is compact and its boundary Σ does not contain critical points of the potential, then in the region B there exists at least one libration.*

Extending the analogy with Riemannian geometry one can say that the theorems of Seifert and Bolotin correspond to the results of Birkhoff and Lyusternik–Fet about closed geodesics on the n -dimensional sphere and an arbitrary simply connected manifold.

The proof of Theorem 4.5 is based on the following assertion.

Lemma 4.2. *There exists $l > 0$ such that for every ε satisfying $0 < \varepsilon \leq \delta$ the domain $\Lambda_\varepsilon = \overline{B} \setminus W_\varepsilon$ contains a geodesic of the Jacobi metric of length less than l that has endpoints on Σ_ε and intersects Λ_δ .*

We now derive Theorem 4.5 from this lemma. For every s in the interval $(0, \delta)$ we denote by $\gamma_s: [a_s, b_s] \rightarrow \Lambda_s$ the geodesic in Lemma 4.2. We assume that γ_s has a natural parametrization and that $a_s < 0 < b_s$ and $\gamma_s(0) \in \Lambda_\delta$. Since the domain Λ_δ is compact, there exists a sequence $s_n \rightarrow 0$ such that

$$\lim_{n \rightarrow \infty} \gamma_{s_n}(0) = x \in \Lambda_\delta, \quad \lim_{n \rightarrow \infty} \gamma_{s_n}(0) = v.$$

Let $\gamma: (a, b) \rightarrow B$ be the unique maximal geodesic of the Jacobi metric satisfying the conditions $\gamma(0) = x$, $\gamma(0) = v$. Clearly, γ is the trajectory of a libration in B whose length does not exceed l .

Lemma 4.2 can be proved by the methods of the Morse theory. We choose small $\delta > 0$, and let $0 < s < \delta$. We introduce the space Ω of piecewise-smooth curves $\gamma: [0, 1] \rightarrow M$ such that $\gamma(0), \gamma(1) \in \Sigma_\varepsilon$. Let Γ be the subspace of Ω consisting of the curves that do not intersect the interior of Λ_δ . On the manifold M one can find a family of smooth functions U_s , $0 < s \leq \varepsilon$, such that U_s coincides with the potential U in the domain Λ_s , $U_s \geq U_\varepsilon$ on M , and $\sup U_s < h$. For every $s \in (0, \varepsilon]$ we define on M the metric $\langle \cdot, \cdot \rangle_s$ that is the M Jacobi metric defined by the potential U_s and energy h . Finally we define the

action functional $F_s: \Omega \rightarrow \mathbb{R}$ by the formula

$$F_s(\gamma) = \int_0^1 \langle \dot{\gamma}, \dot{\gamma} \rangle_s dt.$$

The critical points of the functional F_s are precisely the geodesics of the metric $\langle \cdot, \cdot \rangle_s$ that are orthogonal to Σ_s at their endpoints.

For every $a > 0$ we set $\Omega_s^a = \{\gamma \in \Omega: F_s(\gamma) \leq a\}$ and $\Gamma_s^a = \Gamma \cap \Omega_s^a$.

Lemma 4.3. *If the functional $F_s, 0 < s \leq \varepsilon$, has no critical points in $\Omega_s^a \setminus \Gamma_s^a$, then Γ_s^a is a deformation retract of the space Ω_s^a .*

The idea of the proof of this assertion is to shift Ω_s^a “downward” to Γ_s^a along the integral curves of the vector field of the gradient of the functional F_s . The main point is in using the convexity of the domain W_δ : these “curves of steepest descent” do not go out of the space Γ_s^a .

Lemma 4.2 can be derived from Lemma 4.3 and the following topological fact: since B/Σ is non-contractible, for sufficiently large values of $a > 0$ the space Γ_s^a is not a deformation retract of Ω_s^a . The detailed proof of Theorem 4.5 is contained in [121].

Example 4.9 ([322]). Consider the problem of rotation of a rigid body in an axially symmetric force field with potential U . For the zero value of the constant angular momentum this problem reduces to studying a natural system on a sphere with two degrees of freedom. Theorems 4.3 and 4.5 and the results of the Morse theory imply the following assertion: for every regular value $h > \min U$ the reduced system has a periodic solution with energy h . If $h > \max U$, then by the Lyusternik–Shnirel’man theorem there are at least three distinct non-self-intersecting periodic trajectories on the Poisson sphere. \triangle

Remark 4.3. In [283] the problem of periodic solutions was considered for the “Lorenz” Lagrangian system with Lagrangian $(S\dot{x}, \dot{x})/2 - U(x)$, where (\cdot, \cdot) is the standard scalar product in \mathbb{R}^n and S is a symmetric non-singular linear operator with a single negative eigenvalue. In \mathbb{R}^n we consider the cone $\Sigma = \{y \in \mathbb{R}^n: (Sy, y) < 0\}$. If $x(\cdot)$ is a motion with zero total energy starting in the domain $C = \{U(x) > 0\}$, then $\dot{x} \in \Sigma$. Since Σ consists of two connected components, a passage from one component of Σ into another (change of “direction” of motion) can only happen on the boundary of the domain C . If the point x reaches ∂C , then Proposition 4.1 holds: the point will move along the same trajectory in the opposite direction. In [283] the existence of a libration was proved under the assumption that the domain C is compact and convex and there are no critical points of U on the boundary of C . The proof is based on the application of the topological theorems on fixed points of smooth maps.

In connection with Theorem 4.5 there arises the natural question of a lower estimate of the number of distinct librations in the case where the space B/Σ is simply connected. Example 4.5 shows that a universal estimate cannot exceed the dimension of the region B . In [537] Seifert stated the conjecture that there exist n distinct librations if the region B is diffeomorphic to the n -dimensional disc D^n . We now list the results obtained in this direction.

Suppose that the region of possible motion B is diffeomorphic to D^n , and let $f: (D^n, S^{n-1}) \rightarrow (B, \Sigma)$ be a continuous surjective map. For every two points $x, y \in S^{n-1}$ we define a continuous curve $f_{x,y}: [0, 1] \rightarrow B$ by the formula $f_{x,y}(t) = f((1-t)x + ty)$, $0 \leq t \leq 1$. We assume the map f to be sufficiently smooth, so that for every points $x, y \in S^{n-1}$ the curve $f_{x,y}$ is piecewise-smooth. The abbreviated action F^* is defined on such curves. We set

$$S = \inf_f \sup_{y \in S^{n-1}} F^*(f_{x,y}).$$

Theorem 4.6 (Bolotin). *Suppose that $2F^*(\gamma) > S$ for any libration γ in the region $B \simeq D^n$. Then in the region B there exist n distinct librations $\gamma_1, \dots, \gamma_n$ such that $S/2 < F^*(\gamma_1) \leq \dots \leq F^*(\gamma_n) = S$.*

Example 4.10. We continue the consideration of the problem in Example 4.5. Let $\omega_1 \geq \dots \geq \omega_n > 0$ be the frequencies of the polyharmonic oscillator. As we already saw, this problem always has n distinct librations of energy h :

$$\begin{aligned} \gamma_1: \quad x_1 &= \frac{\sqrt{2h}}{\omega_1} \cos \omega_1 t, & x_i &= 0 \quad (i > 1); \\ \dots & \dots & \dots & \dots \\ \gamma_n: \quad x_i &= 0 \quad (i < n), & x_n &= \frac{\sqrt{2h}}{\omega_n} \cos \omega_n t. \end{aligned}$$

It is easy to calculate that $F^*(\gamma_i) = \pi h / \omega_i$; thus, $F^*(\gamma_1) \leq \dots \leq F^*(\gamma_n)$. In this problem, $S = F^*(\gamma_n)$ and therefore the hypothesis of Theorem 4.6 is equivalent to the inequality $2\omega_n > \omega_1$. △

Theorem 4.7 (Long [399]). *If the potential U is a convex function, then for every value of the total energy $h > \min U$ there exist at least n distinct librations.*

Remark 4.4. The related problem of the existence of periodic solutions of Hamilton's equations in \mathbb{R}^{2n} with a convex Hamiltonian H was considered in [223]. It was proved that if

$$a|z|^2 < H(z) < 2a|z|^2 \tag{4.7}$$

for some $a > 0$, then on each level set $H(z) = h$, $h > 0$, the Hamiltonian system has at least n distinct closed trajectories. For the polyharmonic oscillator

with frequencies $\omega_1 \geq \dots \geq \omega_n > 0$ inequalities (4.7) yield the same condition $2\omega_n > \omega_1$, since the change of variables $q_1 = \sqrt{\omega_i x_i}$, $p_i = \dot{x}_i / \sqrt{\omega_i}$ reduces the equations of the oscillator to the Hamiltonian form with the Hamiltonian

$$H = \frac{1}{2} \sum \omega_i (p_i^2 + q_i^2).$$

Without using inequalities (4.7) (but assuming the convexity) the existence of at least $n/2$ distinct closed trajectories was proved by Long. If the system is reversible or the Hamiltonian H is an even function of z , then there are n periodic trajectories. The most advanced result was obtained for $n = 2$ in [284]: in the region $B \simeq D^2$ there are either exactly two, or infinitely many closed trajectories.

4.2.4 Periodic Oscillations of a Multi-Link Pendulum [325]

In this subsection we obtain an estimate of the number of distinct periodic motions (both librations and rotations) of given energy for the multi-link pendulum considered in Example 4.6. The configuration space of this system is the n -dimensional torus $\mathbb{T}^n = \{\vartheta_1, \dots, \vartheta_n \bmod 2\pi\}$, where $\vartheta_1, \dots, \vartheta_n$ are the angles between the rods and the vertical. We can assume that the configuration space is the covering space $\mathbb{R}^n = \{\vartheta_1, \dots, \vartheta_n\}$ and the Lagrange function L is a function on $T\mathbb{R}^n$ that is 2π -periodic in the ϑ_i . The equilibrium positions are points in \mathbb{R}^n of the form $a = (m_1\pi, \dots, m_n\pi)$, where the m_s are integers. It is easy to see that the Lagrangian admits the reflections of \mathbb{R}^n with respect to the equilibrium positions, that is, the maps $\Lambda_a: \vartheta \rightarrow -\vartheta + 2a$.

Lemma 4.4. *If the trajectory of some motion $\vartheta(t)$ passes through an equilibrium position a (so that $\vartheta(0) = a$), then this curve is invariant under the reflection Λ_a (that is, $\vartheta(-t) = \Lambda_a\vartheta(t) = -\vartheta(t) + 2a$). In particular, $\dot{\vartheta}(-t) = \dot{\vartheta}(t)$.*

Lemma 4.5. *Let $b \in \mathbb{R}^n$ be another equilibrium position ($a \neq b$). If the trajectory of a motion $\vartheta(t)$ contains the points a and b , then*

- 1) *there exists $\tau > 0$ such that $\vartheta(t + \tau) = \vartheta(t) + 2(b - a)$ for all $t \in \mathbb{R}$,*
- 2) *$\dot{\vartheta}(t) \neq 0$ for all $t \in \mathbb{R}$.*

Let h_- and h_+ be, respectively, the lowest and highest values of the potential energy $U(\vartheta)$.

Proposition 4.6. *Let h be a regular value of the potential in the interval (h_-, h_+) . Through each critical point of the potential U lying inside the region $B = \{U \leq h\} \subset \mathbb{T}^n$ there passes at least one librational trajectory. Librations passing through distinct critical points are distinct.*

Corollary 4.3. *The number of distinct librations in the region B is at least the number of equilibrium positions of the pendulum inside B .*

Depending on h , the lower estimate of the number of librations of energy h varies from 1 to $2^n - 1$. This estimate strengthens the result mentioned in Example 4.6. However, the estimate in Example 4.6 is also valid in those cases where the potential has no symmetry property.

◁ *Proof of Proposition 4.6.* Let $a' \in B \subset \mathbb{T}^n$ be an equilibrium position of the pendulum. Since h is a regular value, by Theorem 4.2 there exists a motion $\gamma: [0, \tau] \rightarrow B$ such that $\gamma(0) = a'$ and $\gamma(\tau) \in \Sigma$. According to Lemma 4.4 the smooth curve $\gamma: \mathbb{R} \rightarrow B$ is the required libration whose trajectory contains a' . Librations passing through different critical points are distinct, since otherwise (by Lemma 4.5) the velocity of motion never becomes zero. ▷

We now consider the case where $h > h_+$. Since $\Sigma = \emptyset$, the periodic motions can only be rotations. We investigate the question of the existence of periodic rotations of the n -link pendulum such that the k th link performs N_k complete revolutions over the period of rotation. We call such motions *rotations of type* $]N_1, \dots, N_n[$.

Proposition 4.7. *For every fixed integers N_1, \dots, N_n and every $h > h_+$ there exist 2^{n-1} distinct periodic rotations of type $]N_1, \dots, N_n[$ with total energy h whose trajectories on \mathbb{T}^n pass through pairs of critical points of the potential U .*

◁ Obviously, we can assume from the outset that the integers N_1, \dots, N_n are relatively prime. Consider in $\mathbb{R}^n = \{\vartheta\}$ a pair of critical points a' and a'' of the potential U whose ϑ_k -coordinates differ by πN_k . These points cover distinct points b' and b'' on \mathbb{T}^n . We connect b' and b'' by a shortest geodesic of the Jacobi metric on \mathbb{T}^n . To this geodesic there corresponds a motion $\gamma: \mathbb{R} \rightarrow \mathbb{T}^n$ such that $\gamma(t') = b'$ and $\gamma(t'') = b''$, $t'' > t'$. Let $\vartheta: \mathbb{R} \rightarrow \mathbb{R}^n$ be a curve

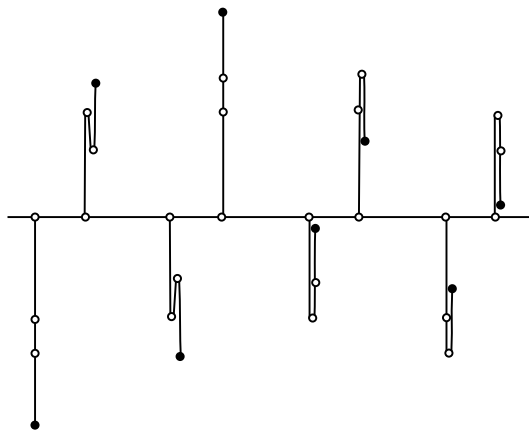

Fig. 4.7.

covering γ such that $\vartheta(t') = a'$ and $\vartheta(t'') = a''$. By Lemma 4.2 there exists $\tau > 0$ such that

$$\vartheta(t + \tau) - \vartheta(t) = 2(a'' - a') = (2\pi N_1, \dots, 2\pi N_n).$$

Consequently, the motion $\gamma: \mathbb{R} \rightarrow \mathbb{T}^n$ is periodic of type $]N_1, \dots, N_n[$ with period τ . Since the integers N_1, \dots, N_n are relatively prime, τ is the smallest period of γ . From this observation and Lemma 4.5 it is easy to deduce that the trajectory of γ on \mathbb{T}^n does not contain equilibrium positions other than b' and b'' . \triangleright

Fig. 4.7 depicts the four pairs of equilibrium positions of a three-link pendulum for different periodic rotations of type $]1, 2, 3[$.

In conclusion we show that under certain conditions periodic rotations of the pendulum exist also for the values $h < h_+$. For that we consider the double pendulum with equal lengths of the rods l and with masses of the points m_1 and m_2 ; the acceleration of gravity is g . The Lagrangian is

$$L = \frac{1}{2} (m_1 + m_2) l^2 \dot{\vartheta}_1^2 + \frac{m}{2} l^2 \dot{\vartheta}_2^2 + m_2 l^2 \dot{\vartheta}_1 \dot{\vartheta}_2 \cos(\vartheta_1 - \vartheta_2) + m_1 g l \cos \vartheta_1 + m_2 g l (\cos \vartheta_1 + \cos \vartheta_2).$$

We consider the case where the value of h is close to h_+ . Fixing the value of m_1 we let m_2 tend to zero. For sufficiently small m_2 the distance between the points $a = (0, 0)$ and $b = (0, \pi)$ is less than the sum of the distances from these points to the boundary of Σ . Indeed, $d(a, b)$ does not exceed the length of the segment $\{\vartheta_1 = 0, 0 \leq \vartheta_2 \leq \pi\} \subset \mathbb{R}^2$, which is equal to

$$\sqrt{m_2} l \int_0^\pi \sqrt{h + m_1 g l + m_2 g l (1 + \cos \vartheta_2)} d\vartheta_2.$$

This quantity tends to zero as $m_2 \rightarrow 0$. Since the region B is little different from the domain $\{h + m_1 g l \cos \vartheta_1 \geq 0\}$, we have

$$\lim_{m_2 \rightarrow 0} \partial(a) = \frac{\sqrt{m_1} l}{2} \oint \sqrt{h + m_1 g l \cos \vartheta_1} d\vartheta_1 > 0.$$

Consequently, for small m_2 we have the inequality $d(a, b) < \partial(a) + \partial(b)$. By Proposition 4.3 there exists a shortest geodesic of the Jacobi metric contained inside B and connecting the points a and b . To this geodesic there corresponds a solution of the equations of motion with total energy h . Since the points a and b are equilibrium positions, by Lemma 4.5 the solution thus found is a periodic rotation.

4.3 Periodic Trajectories of Non-Reversible Systems

4.3.1 Systems with Gyroscopic Forces and Multivalued Functionals

Up to now we considered the situation where a “seminatural” Lagrangian $L = L_2 + L_1 + L_0$ was a single-valued function on the tangent bundle TM . In particular, the 1-form $\omega \equiv L_1$ was defined and single-valued everywhere on M . Consequently, its exterior differential $\Omega = d\omega$, the 2-form of gyroscopic forces, was exact. It is useful to generalize this situation by considering mechanical systems with a closed (but not necessarily exact) form of gyroscopic forces.

Example 4.11. The motion of a charge on Euclidean plane \mathbb{R}^2 with Cartesian orthonormal coordinates x, y in a magnetic field (directed along the z -axis) with strength $H(x, y)$ is described by the equations $\ddot{x} = -H\dot{y}$, $\ddot{y} = H\dot{x}$. The form of gyroscopic forces Ω is obviously equal to $H dx \wedge dy$. This form is of course exact. For example, if $H = \text{const}$, then $\omega = H(y dx - x dy)/2$. We consider the special case where the magnetic field $H(x, y)$ is 2π -periodic in x and y . Then for the configuration space one can take the two-dimensional torus $\mathbb{T}^2 = \{x, y \bmod 2\pi\}$ with a planar metric. The form ω is exact only if the total flux of the magnetic field

$$\bar{H} = \int_0^{2\pi} \int_0^{2\pi} H dx \wedge dy$$

is equal to zero. △

Example 4.12. Consider the motion of a charge on the surface of the unit sphere $\langle \mathbf{r}, \mathbf{r} \rangle = 1$ in three-dimensional Euclidean space $\mathbb{R}^3 = \{\mathbf{r}\}$. Suppose that a magnetic field of constant magnitude is directed orthogonally to the surface of the sphere. The equation of motion can be represented with the Lagrange multiplier as

$$\ddot{\mathbf{r}} = H(\dot{\mathbf{r}} \times \mathbf{r}) + \lambda \mathbf{r}, \quad \langle \mathbf{r}, \mathbf{r} \rangle = 1; \quad H = \text{const}.$$

Hence, $\lambda = -\langle \dot{\mathbf{r}}, \dot{\mathbf{r}} \rangle$. Since the total energy $E = \langle \dot{\mathbf{r}}, \dot{\mathbf{r}} \rangle / 2$ is conserved, we have $\lambda(t) = -2E = \text{const}$. One can show that the trajectories of this equation on the unit sphere with a fixed value of the energy E are circles of radius ρ , where

$$\rho^2 = \frac{2E/H^2}{1 + 2E/H^2}. \quad (4.8)$$

In Example 4.11 the “Larmor radius” is $\rho = \sqrt{2E}/H$. The form of gyroscopic forces is $\Omega = H d\sigma$, where $d\sigma$ is the area element on the unit sphere. This form is not exact, since the total flux of the magnetic field through the sphere is equal to $4\pi H \neq 0$. △

Example 4.13. The rotation of a rigid body with a fixed point in an axially symmetric force field is described by the Euler–Poisson system of equations (in the moving space)

$$\dot{\mathbf{M}} = \mathbf{M} \times \boldsymbol{\omega} + \mathbf{e} \times U', \quad \dot{\mathbf{e}} = \mathbf{e} \times \boldsymbol{\omega}.$$

Here $\mathbf{M} = I\boldsymbol{\omega}$ is the angular momentum of the rigid body, $\boldsymbol{\omega}$ its angular velocity, I the inertia tensor, \mathbf{e} a unit vector of the symmetry axis of the force field, and $U(\mathbf{e})$ the potential. It is easy to show that on a fixed level of the area integral

$$\{(\mathbf{M}, \mathbf{e}) \in \mathbb{R}^6 : \langle \mathbf{M}, \mathbf{e} \rangle = c, \langle \mathbf{e}, \mathbf{e} \rangle = 1\}$$

we obtain a system with gyroscopic forces. The configuration space is the two-dimensional sphere S^2 . The form Ω_c is not exact for $c \neq 0$, since

$$\int_{S^2} \Omega_c = 4\pi c. \quad (4.9)$$

A related example is provided by Kirchhoff's problem of the motion of a rigid body in a boundless ideal fluid (see [366]). \triangle

We return to the study of the general case where $h > \sup U$. Consider a domain $Q \subset M$ such that the form Ω is exact in Q , so that $\Omega = d\omega_Q$. Suppose that a curve $x: [0, 1] \rightarrow M$ is entirely contained in Q . Then on this curve we can define the value of the abbreviated action

$$F_Q^* = \int_0^1 (|\dot{x}(t)|_h + \omega_Q(\dot{x}(t))) dt,$$

where $|\cdot|_h$ is the Jacobi metric, which is equal to $2\sqrt{(h + L_0)L_2}$; see §4.2. We fix a set of 1-forms ω_Q for all the domains Q where the form Ω is exact. If the curve $x(\cdot)$ lies in the intersection of domains $Q_1 \cap Q_2$, then $\Omega = d\omega_{Q_1} = d\omega_{Q_2}$ and therefore

$$F_{Q_1}^*(x(\cdot)) - F_{Q_2}^*(x(\cdot)) = \int_{x(\cdot)} (\omega_{Q_1} - \omega_{Q_2}).$$

Since the form Ω is closed, by Stokes' formula the value of this integral does not change if we vary $x(\cdot)$ as a curve with fixed ends, or as a closed curve. Consequently, the set of local values $F_Q^*(x(\cdot))$ defines a "multivalued functional" on the space K^+ of closed oriented curves and on the space $K(x_1, x_2)$ of paths connecting two points $x_1, x_2 \in M$. One can say that the variation δF^* is a uniquely defined 1-form on the space K^+ (or $K(x_1, x_2)$), but its integrals over various paths in K^+ (or K), which are variations of the curves, in general define a multivalued function on K^+ (or on $K(x_1, x_2)$). Since locally F^* can be regarded as a single-valued functional, it enjoys all the local

properties of the classical action (in particular, Theorem 4.1 is valid, Morse's index theorem holds, and so on).

The multivalued functional F^* becomes single-valued on passing to some infinite-sheeted covering $\widehat{K} \rightarrow K^+$ (respectively, $\widetilde{K}(x_1, x_2) \rightarrow K(x_1, x_2)$). However, in contrast to the classical Morse theory, the single-valued functional F^* may not be bounded below on \widehat{K} (or on \widetilde{K}). This circumstance creates additional difficulties in using the gradient descent for the study of the existence of periodic trajectories, or trajectories with fixed ends.

Multivalued functionals were introduced by S. Novikov, who developed in [484, 485, 487] the extended Morse theory for the periodic variational problem. We give two simple examples showing that the Morse theory is inapplicable to multivalued functionals in the space $K(x_1, x_2)$. The first of them complements Example 4.3.

Example 4.14 ([487]). Consider the problem of the motion of a charged particle on the plane \mathbb{R}^2 in a constant magnetic field (see Example 4.11). Because the Larmor radius is bounded for a fixed value of the energy, one cannot connect any two points in \mathbb{R}^2 by an extremal of the functional F^* . The reason is that the functional F^* is unbounded below on the space of curves $K(x_1, x_2)$. Indeed, let us connect any two points $x_1, x_2 \in \mathbb{R}^2$ by a long curve γ_1 and a short curve γ_2 . Clearly, $F^*(\gamma_1) \sim F^*(\gamma_2^{-1}\gamma_1)$. The action of F^* on the closed curve $\gamma_2^{-1}\gamma_1$ is the sum of two quantities: one is proportional to the length of γ_1 , and the other to the area bounded by the contour $\gamma_2^{-1}\gamma_1$. By enlarging γ_1 and choosing its orientation we can ensure that $F^*(\gamma_1)$ tends to $-\infty$. It may seem that this phenomenon is caused by the fact that \mathbb{R}^2 is not compact. The following example shows that this is not the case. \triangle

Example 4.15 ([487]). Consider the system with gyroscopic forces in Example 4.12. For a fixed value of the total energy E and large values of the strength of the magnetic field H , the Larmor radius is small (see (4.8)), which fact again leads to the insolubility of the two-point variational problem. In this example the configuration manifold S^2 is compact, but the functional F^* is not single-valued. \triangle

Unlike the two-point problem, the periodic problem of variational calculus always has trivial solutions: the one-point curves $x(t) \equiv x_0$ at which the functional F^* has local minimum (see §4.1.3).

Novikov stated the following important assertion [487]. Suppose that the configuration space M is compact, simply connected, and $H^2(M) \neq 0$. Then for every value of the total energy $h > \max(-L_0)$ the equation of motion has a periodic solution with the given energy $h = L_2 - L_0$.

The idea of the proof is as follows. As already mentioned, the functional F^* always has trivial one-point extremals $x(t) \equiv x_0$. These extremals form an n -dimensional submanifold $N \subset K^+$ diffeomorphic to M . Each of these extremals is a local minimum of the multivalued functional F^* . On every sheet

of the covering $f: \widehat{K} \rightarrow K^+$ the full inverse image

$$f^{-1}(N) = N_0 \cup N_1 \cup \dots$$

gives a manifold of local minima of the multivalued functional F^* . Since M is simply connected, there exists a natural homotopy $g: M \times [0, 1] \rightarrow \widehat{K}$ connecting the submanifolds N_0 and N_1 . We restrict the functional F^* to the image of $M \times [0, 1]$ and begin “shifting” the map g downward along the gradient of F^* ; here the ends N_0 and N_1 remain fixed. Since $H^2(M) \neq 0$, we have $\pi_2(M) \neq 0$ and therefore the space of curves K^+ is not simply connected. The gradient descent gives us the required non-trivial stationary “saddle” critical point.

However, a rigorous justification of this construction is a difficult problem. The reader should be aware of certain inaccuracies in [484, 485, 487]. They are related to the fact that the space of oriented closed curves without self-intersections is considered in these papers. But an application of the gradient descent may give rise to self-intersections in the non-reversible case. Concerning corrections see the survey [575] and the papers [486, 573, 574].

4.3.2 Applications of the Generalized Poincaré Geometric Theorem

In some cases the existence of periodic trajectories of mechanical systems with gyroscopic forces can be established by the generalizations of the well-known Poincaré geometric theorem on fixed points of symplectic diffeomorphisms. As an example we consider the motion of a charge on the “Euclidean” two-dimensional torus $\mathbb{T}^2 = \{x, y \bmod 2\pi\}$ under the action of a magnetic field with strength $H: \mathbb{T}^2 \rightarrow \mathbb{R}$ (see Example 4.11). The motion of the charge is described by the equations

$$\ddot{x} = -H(x, y)\dot{y}, \quad \ddot{y} = H(x, y)\dot{x}.$$

The total energy $(\dot{x}^2 + \dot{y}^2)/2 = h$ is of course conserved.

Theorem 4.8. *If the magnetic field H does not vanish anywhere, then for every fixed value of the energy $h > 0$ there are at least four closed trajectories counting their multiplicities, and at least three geometrically distinct ones. If $H^2(x, y) > h$ for all $(x, y) \in \mathbb{T}^2$, then there exist at least four (counting multiplicities) closed trajectories homotopic to zero.⁴*

◁ For every $h > 0$ the energy surface $\dot{x}^2 + \dot{y}^2 = 2h$ is diffeomorphic to the three-dimensional torus \mathbb{T}^3 with the angle coordinates $x, y, \varphi = \text{arccot}(\dot{y}/\dot{x})$. The equations of motion on \mathbb{T}^3 have the form

$$\dot{x} = \sqrt{2h} \cos \varphi, \quad \dot{y} = \sqrt{2h} \sin \varphi, \quad \dot{\varphi} = H(x, y).$$

⁴ Cf. Theorem 2 in [486].

Since $H \neq 0$, the angle variable φ changes monotonically. Suppose for definiteness that $\dot{\varphi} > 0$. We rewrite the equations of motion regarding φ as new “time”:

$$x' = \frac{\sqrt{2h} \cos \varphi}{H}, \quad y' = \frac{\sqrt{2h} \sin \varphi}{H}, \quad (\cdot)' = \frac{d(\cdot)}{d\varphi}.$$

The symplectic structure $H(x, y) dx \wedge dy$ is preserved by the phase flow of these equations. Let $x \mapsto x + f(x, y)$, $y \mapsto y + g(x, y)$ be a symplectic map of the torus $\mathbb{T}^2 = \{x, y \bmod 2\pi\}$ onto itself that is a map over time $\varphi = 2\pi$ (Fig. 4.8).

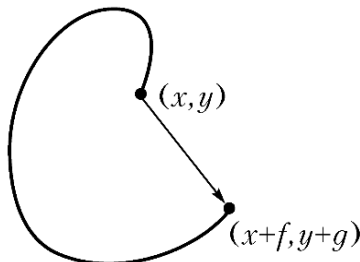

Fig. 4.8.

One can show that this map preserves the centre of mass of the torus \mathbb{T}^2 , that is,

$$\iint_{\mathbb{T}^2} fH dx \wedge dy = \iint_{\mathbb{T}^2} gH dx \wedge dy = 0.$$

According to the generalized Poincaré theorem stated by Arnold ([10], Appendix 9) and completely proved in [196], a map over the period has at least four fixed points (counting multiplicities) among which there are necessarily three geometrically distinct ones. To complete the proof it remains to verify that $|f|, |g| < 2\pi$ if $\min H^2 > h$. For example, let us estimate

$$|f|^2 = \left| \int_0^{2\pi} \frac{\sqrt{2h} \cos \varphi d\varphi}{H(x(\varphi), y(\varphi))} \right|^2 \leq 2h \int_0^{2\pi} \cos^2 \varphi d\varphi \int_0^{2\pi} \frac{d\varphi}{H^2} \leq \frac{(4\pi)^2 h}{\min H^2},$$

whence $|f| \leq 2\pi(\sqrt{h}/\min |H|)$, as required. \triangleright

Remark 4.5. Let us complicate the problem by adding conservative forces with potential $U: \mathbb{T}^2 \rightarrow \mathbb{R}$. Consider the motion of the charge under the condition that $\max U < h$. Since

$$\dot{\varphi} = H + \frac{U'_y \dot{x} - U'_x \dot{y}}{2(h - U)},$$

the variable φ changes monotonically if

$$|H| > \frac{\sqrt{U_x'^2 + U_y'^2}}{\sqrt{2(h - U)}}. \tag{4.10}$$

This inequality guarantees the existence of three periodic trajectories with energy h . If $h < \max U$, then the angle variable φ does not change monotonically everywhere; hence in this case nothing definite can be said about the existence of closed trajectories.

In [346] condition (4.10) for the existence of three closed orbits is derived in the most general case, where the metric on the torus is arbitrary.

We mention one more route to four cycles on a torus with a magnetic field suggested by Arnold. For that, fixing the centre of mass of a disc on the torus and its “magnetic” area

$$\iint H \, dx \wedge dy$$

we minimize the length of the boundary. If the resulting function of the centre of mass as a point on \mathbb{T}^2 turns out to be smooth, then its critical points (there are at least four of them, counting multiplicities) give us closed trajectories bounding the fixed area. Varying then the area from zero to infinity we obtain closed trajectories of given energy. So far this programme has not been realized. This approach is attractive because it can possibly be generalized to surfaces other than the torus. But this would require giving an appropriate definition of the centre of mass.

We also consider the problem of the motion of a charge on a sphere in a magnetic field (Example 4.12). In the absence of a magnetic field the point moves periodically along great circles. Seifert’s theorem [538] implies the existence of periodic trajectories in the presence of a weak magnetic field.

Questions of the existence of closed orbits on arbitrary closed surfaces in strong magnetic fields were considered in Ginzburg’s paper [258]. Using the appropriate generalization of the Poincaré geometric theorem he obtained the following estimates for the number k of periodic trajectories in a strong magnetic field in terms of the genus g of the surface:

- a) if $g = 0$, then $k \geq 2$;
- b) if $g \geq 1$, then $k \geq 3$ (counting multiplicities, $k \geq 2g + 2$).

For the torus ($g = 1$) assertion b) coincides with the result of [346].

4.4 Asymptotic Solutions. Application to the Theory of Stability of Motion

In this section we consider motions of mechanical systems that tend to equilibria as time tends to infinity. One can reduce to this problem the study

of motions that are asymptotic to arbitrary given motions (not only asymptotic to equilibria). Indeed, let $x_0(\cdot)$ be a solution of Lagrange's equation $[L(\dot{x}, x, t)]_x = 0$. We set $y = x - x_0(t)$ and $\widehat{L}(\dot{y}, y, t) = L(\dot{y} + \dot{x}_0, y + x_0, t)$. Obviously, $y(t) \equiv 0$ is a solution of the equation $[\widehat{L}]_y = 0$. If $x(t) \rightarrow x_0(t)$ as $t \rightarrow \infty$, then $y(t) \rightarrow 0$.

4.4.1 Existence of Asymptotic Motions

We consider a non-autonomous Lagrangian system (M, L) with smooth Lagrange function $L: TM \times \mathbb{R} \rightarrow \mathbb{R}$. Let $\langle \cdot, \cdot \rangle$ be some complete Riemannian metric on M .

Definition 4.2. The Lagrangian system (M, L) is said to be *regular* if there exist positive constants c_1, c_2, c_3, c_4 such that

- 1) $c_1 \langle \dot{x}, \dot{x} \rangle - c_2 \leq L(\dot{x}, x, t)$,
- 2) $c_3 \langle v, v \rangle \leq L''_{\dot{x}, \dot{x}} v \cdot v \leq c_4 \langle v, v \rangle$

for all $(\dot{x}, x, t) \in TM \times \mathbb{R}$ and $v \in TM$.

If the configuration space is compact, then the definition of regularity is independent of the choice of the Riemannian metric on M .

Example 4.16. Suppose that the Lagrange function is a periodic (or almost periodic) function of time and has the form

$$L = \frac{1}{2} \langle \dot{x}, \dot{x} \rangle_t + \langle v(x, t), \dot{x} \rangle_t + V(x, t),$$

where $\langle \cdot, \cdot \rangle_t$ is a Riemannian metric on M depending on time, v is a smooth vector field, and $V: M \times \mathbb{R} \rightarrow \mathbb{R}$ is some smooth function. Conditions 1), 2) are automatically satisfied if the metric $\langle \cdot, \cdot \rangle_t$ is complete for all t and the functions $\langle v, v \rangle_t$ and V are bounded above. △

Throughout this section we assume that conditions 1), 2) hold. These conditions guarantee the global existence of the smooth Hamiltonian function $H: T^*M \times \mathbb{R} \rightarrow \mathbb{R}$ that is dual (in the sense of the Legendre transformation) to the Lagrange function L . We define a smooth function $H_0: M \times \mathbb{R} \rightarrow \mathbb{R}$ as the restriction of the Hamiltonian H to the set of points in $T^*M \times \mathbb{R}$ where the canonical momenta vanish: $y = L'_x = 0$.

Suppose that $x(t) = a = \text{const}$ is a solution of Lagrange's equation $[L] = 0$, so that a is an equilibrium position. Without loss of generality we can assume that $H_0(a, t) = 0$.

Definition 4.3. The function $H_0: M \times \mathbb{R} \rightarrow \mathbb{R}$ is said to be *negative-definite* if for any neighbourhood D of the point a there exists $\varepsilon > 0$ such that $H(x, t) \leq -\varepsilon$ for all $x \notin D$ and $t \in \mathbb{R}$.

Theorem 4.9 ([130]). *If the function H_0 is negative-definite, then for every $x_0 \in M$ and $\tau \in \mathbb{R}$ there exists a motion $x: [\tau, +\infty) \rightarrow M$ such that $x(\tau) = x_0$ and $x(t) \rightarrow a$ as $t \rightarrow +\infty$.*

To establish the existence of motions asymptotic to the equilibrium a as $t \rightarrow -\infty$ it is sufficient to apply Theorem 4.9 to the Lagrangian system (M, \widehat{L}) , where $\widehat{L}(\dot{x}, x, t) = L(-\dot{x}, x, -t)$. If $x(t)$ is a motion of the Lagrangian system (M, L) , then $x(-t)$ is a motion of the system (M, \widehat{L}) .

◁ *Proof of Theorem 4.9.* We may assume that L vanishes at the equilibrium position: $L(0, a, t) \equiv 0$ for all t . The definition of the Legendre transformation and the regularity condition imply that

$$H = \sup_{\dot{x}} (y \cdot \dot{x} - L).$$

Consequently,

$$L(\dot{x}, x, t) \geq -H_0(x, t) \geq 0 = L(0, a, t). \tag{4.11}$$

Let $x_0 \neq a$ and $\tau \in \mathbb{R}$. We introduce the set $\Omega(x_0, \tau)$ of piecewise-continuously differentiable curves $x: [\tau, +\infty) \rightarrow M$ such that $x(\tau) = x_0$ and $x(t) \equiv a$ for all sufficiently large $t > \tau$. On the set $\Omega(x_0, \tau)$ the Hamiltonian action functional is defined:

$$F(x(\cdot)) = \int_{\tau}^{\infty} L(\dot{x}(t), x(t), t) dt.$$

Let d be the distance between points of the complete Riemannian space $(M, \langle \cdot, \cdot \rangle)$. For any curve $x(\cdot)$ in $\Omega(x_0, \tau)$ and any instants $t_2 > t_1 \geq \tau$, by the Cauchy–Bunyakovskij inequality we have the estimate

$$d^2(x(t_1), x(t_2)) \leq \left(\int_{t_1}^{t_2} |\dot{x}(t)| dt \right)^2 \leq (t_2 - t_1) \int_{t_1}^{t_2} |\dot{x}(t)|^2 dt.$$

The regularity condition 1) implies the inequality

$$d^2(x(t_1), x(t_2)) \leq \frac{t_2 - t_1}{c_1} (F(x(\cdot)) + c_2(t_2 - t_1)). \tag{4.12}$$

For a value $T > \tau$ we denote by Ω_T the set of curves $x(\cdot) \in \Omega(x_0, \tau)$ such that $x(t) \equiv a$ for $t \geq T$. By inequality (4.12) every subset of Ω_T on which the functional F is bounded is uniformly bounded and uniformly continuous. Consequently, taking into account the inequality $F \geq 0$ we obtain by Arzelá’s theorem that $F: \Omega_T \rightarrow \mathbb{R}$ attains its infimum at some continuous curve $x_T: [\tau, T] \rightarrow M$. The regularity condition implies that $x_T(\cdot) \in \Omega_T$ (see [490]).

The function $T \mapsto F(x_T)$, $T > \tau$, is continuous, non-negative, and non-increasing. It follows from inequality (4.12) that the family of curves

$\{x_T(\cdot)\}_{T \geq \tau_0}$ ($\tau_0 > \tau$) is uniformly bounded and equicontinuous. Since the distance d is complete, applying again Arzelá's theorem and the diagonal process we find a sequence $\tau_n \rightarrow +\infty$ such that for any $T > \tau$ the sequence $x_{\tau_n}(\cdot)$ converges to a continuous curve $x: [\tau, +\infty) \rightarrow M$ uniformly on $[\tau, T]$. Since at the curve $x_{\tau_n}: [\tau, T] \rightarrow M$ the functional F has a minimum on the class of curves with endpoints at x_0 and $x_{\tau_n}(T)$, the limit curve $x: [\tau, T] \rightarrow M$ is an extremal of the functional F on the set of curves with ends at the points x_0 and $x(T) = \lim_{n \rightarrow \infty} x_{\tau_n}(T)$. Consequently, $x(\cdot)$ is a motion, and

$$\int_{\tau}^T L(\dot{x}(t), x(t), t) dt = \lim_{n \rightarrow \infty} \int_{\tau}^T L(\dot{x}_{\tau_n}(t), x_{\tau_n}(t), t) dt \leq \lim_{n \rightarrow \infty} F(x_{\tau_n}).$$

Thus,

$$\int_{\tau}^{\infty} L(\dot{x}(t), x(t), t) dt \leq \inf \{F(x(\cdot)) : x(\cdot) \in \Omega(x_0, \tau)\}. \quad (4.13)$$

Since the function H_0 is negative-definite, inequality (4.11) and the convergence of the integral (4.13) imply that $x(t) \rightarrow a$ as $t \rightarrow +\infty$. \triangleright

Example 4.17. To the Lagrange function in Example 4.16 there corresponds the Hamiltonian function

$$H = \frac{1}{2} \langle y, y \rangle_t^* - y \cdot v(x, t) + \frac{1}{2} \langle v, v \rangle_t + U(x, t),$$

where $\langle \cdot, \cdot \rangle_t^*$ is the quadratic form on T_x^*M conjugate to the metric $\langle \cdot, \cdot \rangle_t$ on T_xM . If a point $x = a$ is an equilibrium position, then by Theorem 4.9 there exist motions asymptotic to the point a if the inequality

$$\frac{1}{2} \langle v(x, t), v(x, t) \rangle_t + U(x, t) < U(a, t) \quad (4.14)$$

holds for all $x \neq a$ and $t \in R$.

In the autonomous case the existence of asymptotic motions can also be established by the following method. If inequality (4.14) holds, then the integrand for the Maupertuis action (that is, $2\sqrt{L_0 L_2} + L_1$) is positive-definite in the domain $M \setminus \{a\}$. Consequently, the Maupertuis action attains the smallest value on the set of piecewise-smooth curves on M with ends at the points x_0 and a . This value is attained precisely at the trajectory of the required asymptotic motion. \triangle

Theorem 4.10 ([122]). *Suppose that H is almost periodic in t , the function $H_0: M \times \mathbb{R} \rightarrow \mathbb{R}$ is negative-definite, and M is compact. Then there exists a motion $x: \mathbb{R} \rightarrow M$ that is doubly asymptotic to the equilibrium $a \in M$ (that is, $x(t) \rightarrow a$ as $t \rightarrow \pm\infty$).*

4.4.2 Action Function in a Neighbourhood of an Unstable Equilibrium Position

We again assume that the function $H_0: M \times \mathbb{R} \rightarrow \mathbb{R}$ is negative-definite in a neighbourhood of an equilibrium position $x = a$. We introduce a function $S: M \times \mathbb{R} \rightarrow \mathbb{R}$ by the formula

$$S(x, \tau) = \inf \{ F(z(\cdot)) : z(\cdot) \in \Omega(x, \tau) \}.$$

According to Theorem 4.9 we can associate with every point $(x, \tau) \in M \times \mathbb{R}$ an asymptotic motion $z: [\tau, +\infty) \rightarrow M$ such that $z(\tau) = x$ and $\lim_{t \rightarrow \infty} z(t) = a$.

Proposition 4.8. *If the Lagrangian L is periodic in t , then*

- a) $\lim_{t \rightarrow \infty} \dot{z}(t) = 0$,
- b) $\int_{\tau}^{\infty} L(\dot{z}(t), z(t), t) dt = S(x, \tau)$.

◁ Let T be the period of the Lagrange function. Since the integral (4.13) converges, it follows that for large T' the Lagrangian becomes arbitrarily small at some points of the interval $[T', T' + T]$. Inequality (4.11) shows that at these points the velocity \dot{z} is small. Conclusion a) follows from this observation because the equations of motion are periodic in t . Conclusion b) is a consequence of a) and inequality (4.13). ▷

Remark 4.6. Of course, Proposition 4.8 is also valid under more general assumptions about the explicit dependence of the Lagrangian on time.

The action function S is positive-definite and continuous but possibly non-differentiable.

Theorem 4.11 ([130]). *Suppose that the function L is periodic in t and an equilibrium position $a \in M$ is a point of non-degenerate maximum of the function H_0 for every instant. Then there exists a neighbourhood $D \subset M \times \mathbb{R}$ of the straight line $\{a\} \times \mathbb{R}$ such that*

- a) *for every point $(x, \tau) \in D$ there exists a unique motion $z: [\tau, +\infty) \rightarrow M$ asymptotic to the point a inside D ;*
- b) *the function S is smooth on D , has a non-degenerate minimum on the straight line $\{a\} \times \mathbb{R}$, and satisfies the Hamilton-Jacobi equation $S'_t + H(S'_x, x, t) = 0$;*
- c) *if y is the momentum along the motion $z(\cdot)$, then $y(t) = S'_x(z(t), t)$.*

◁ By the stable manifold theorem (see, for example, [481]) the phase trajectories of the Lagrangian system (M, L) that are asymptotic to the point $(y, x) = (0, a) \in T^*M$ fill a smooth invariant submanifold $W \subset T^*M \times \mathbb{R}$, which is diffeomorphically projected onto some neighbourhood of the straight

line $\{a\} \times \mathbb{R}$. This proves conclusion a). We represent W as the graph of a smooth map $f: D \rightarrow T^*M \times \mathbb{R}$. If $z: [\tau, +\infty) \rightarrow M$, $z(\tau) = x$, is a motion asymptotic to the equilibrium $z \equiv a$, then $\dot{z}(t) = H'_y(f(z, t), z, t)$. By the theorem on smooth dependence of solutions on initial data the function $z(t, x, \tau)$, $z(t) = x$, is smooth. Hence the action function $S(x, \tau)$ also depends smoothly on $(x, \tau) \in D$. Using formula b) of Proposition 4.8 one can easily obtain

$$dS(x, \tau) = y(x, \tau) dx - H(y(x, \tau), x, \tau) d\tau, \quad y = f(x, \tau).$$

From this we obtain the required formulae $y = S'_x$ and $S'_\tau + H(S'_x, x, \tau) = 0$. ▷

Example 4.18. Consider a natural mechanical system $(M, \langle \cdot, \cdot \rangle, U)$. Suppose that a point $a \in M$ is a non-degenerate local maximum of the potential energy U . Theorem 4.11 asserts that the trajectories asymptotic to the point a intersect the level surfaces of the action function $S(x)$ at right angle (in the sense of the metric $\langle \cdot, \cdot \rangle$); the function S itself satisfies the nonlinear equation

$$\langle S'_x, S'_x \rangle^* = U(x) - U(a).$$

If the equilibrium is degenerate, then this equation may not have smooth solutions. Here is a simple example (see [157]):

$$S_x'^2 + S_y'^2 = x^4 + \varepsilon x^2 y^2 + y^4, \quad \varepsilon > -2. \tag{4.15}$$

It is easy to show that for $\varepsilon \neq 2$ and $\varepsilon \neq 6$ equation (4.15) has no infinitely differentiable solutions in a neighbourhood of the point $x = y = 0$. Non-smooth solutions may exist. For example, for $\varepsilon = 7$ equation (4.15) has solution $S(x, y) = xy\sqrt{x^2 + y^2}$, which is only of class C^2 . △

In conclusion we remark that the statement of the problem and the first results on the existence of asymptotic motions of conservative mechanical systems apparently go back to the papers of Kneser of 1897.

4.4.3 Instability Theorem

If a Lagrangian system (M, L) has motions asymptotic to an equilibrium $a \in M$, then for the system (M, \widehat{L}) where the function \widehat{L} is obtained from L by reversing time, this equilibrium will obviously be unstable. Thus, according to Theorem 4.9 the negative-definiteness of the function $H_0: M \times \mathbb{R} \rightarrow \mathbb{R}$ is a sufficient condition for instability. This condition can be weakened.

Theorem 4.12 ([130]). *If $H_0 \leq 0$ for all $(x, y) \in M \times \mathbb{R}$, then for every $\varepsilon > 0$, $x_0 \in M$, and $\tau_0 \in \mathbb{R}$ there exists $\tau > \tau_0$ and a motion $x: [\tau_0, \tau] \rightarrow M$ such that $x(\tau_0) = x_0$, $x(\tau) = a$, and $|\dot{x}(\tau)| \leq \varepsilon$.*

To prove instability it is sufficient to apply the theorem to the Lagrangian system (M, \widehat{L}) . Theorem 4.12 is proved by the method of § 4.4.1.

Example 4.19. For the seminatural system in Example 4.16 a condition for the instability of an equilibrium is given by (4.14) with non-strict inequality. In the autonomous case this condition was noted by Hagedorn [272]. \triangle

4.4.4 Multi-Link Pendulum with Oscillating Point of Suspension

We now apply the general assertions established above to the problem of the motion of a planar n -link pendulum (see Example 4.6) with vertically oscillating point of suspension. The Lagrange function has the form

$$L(\dot{\vartheta}, \vartheta, t) = \frac{1}{2} \sum_{i,j=1}^n M_{\max(i,j)} l_i l_j \cos(\vartheta_i - \vartheta_j) \dot{\vartheta}_i \dot{\vartheta}_j + \dot{f}(t) \sum_{i=1}^n M_i l_i \sin \vartheta_i \dot{\vartheta}_i - \sum_{i=1}^n M_i l_i \cos \vartheta_i,$$

where $M_i = \sum_{j=i}^n m_j$ and $f(t)$ is the height of the suspension point of the pendulum. Since the configuration space $\mathbb{T}^n = \{\vartheta \bmod 2\pi\}$ is compact, the system (\mathbb{T}^n, L) is regular if $\dot{f}^2(\cdot)$ is a smooth bounded function of time. Let $a = (\pi, \dots, \pi)$ be the upper equilibrium of the pendulum.

Proposition 4.9. *If the inequality*

$$\dot{f}^2 < g \min_s \left(\frac{m_s l_s}{M_s} \right) \tag{4.16}$$

holds for all t , then condition (4.14) is satisfied.

This assertion remains valid if the sign $<$ in inequalities (4.16) and (4.14) is replaced by \leq .

Corollary 4.4. *If $n = 1$, then the upper equilibrium is unstable if $\dot{f}^2(t) \leq gl$ for all $t \in R$.*

Remark 4.7. The sufficient condition for stability in linear approximation obtained for $f \gg l$ by the averaging method has the form $\dot{f}^2 > gl$ (Bogolyubov [15]). If inequality (4.16) holds, then by Theorem 4.9 there exist motions of the pendulum starting at an arbitrary instant in an arbitrary position and asymptotic to the upper equilibrium $\vartheta = a$. Moreover, according to Theorem 4.10, in this case there exist motions of the pendulum that are doubly asymptotic to the point $a \in \mathbb{T}^n$.

Proposition 4.10. *If the function $f(t)$ is even and inequality (4.14) holds, then there exist at least $2^n - 1$ distinct motions of the pendulum doubly asymptotic to the upper equilibrium.*

◁ Indeed, apart from the upper one, there exist $2^n - 1$ more equilibria a_i , which are invariant under the reflection $\vartheta \rightarrow -\vartheta$ (see §4.2.4). Let $\vartheta: [0, +\infty) \rightarrow \mathbb{T}^n$, $\vartheta(0) = a_i$, be a motion of the pendulum asymptotic to the point a as $t \rightarrow +\infty$. Since the map $(\dot{\vartheta}, \vartheta, t) \rightarrow (\dot{\vartheta}, -\vartheta, -t)$ preserves the Lagrangian, the motion $\widehat{\vartheta}(t) = -\vartheta(-t)$ is asymptotic to a as $t \rightarrow -\infty$. Since $\widehat{\vartheta}(0) = \dot{\vartheta}(0)$, the motion $\vartheta: \mathbb{R} \rightarrow \mathbb{T}^n$ is the required doubly asymptotic motion. ▷

4.4.5 Homoclinic Motions Close to Chains of Homoclinic Motions

For simplicity we consider a Lagrangian system with configuration space M and Lagrange function $L(q, \dot{q}, t)$ that is periodic in time. Suppose that L satisfies the natural regularity conditions (which hold, for example, for $L = \frac{1}{2}|\dot{q}|^2 - V(q, t)$). Similar results are valid for general Hamiltonian systems. Suppose that 0 is a hyperbolic equilibrium position that is a maximum point of the potential energy. Poincaré called motions that are doubly asymptotic to an equilibrium *homoclinic*⁵ to this equilibrium. Below we discuss homoclinic motions that are close to chains of homoclinic motions separated in time. Such homoclinic motions are often expressively called “multibumps” in the literature.

Suppose that L vanishes at the equilibrium position. Then the motions homoclinic to 0 are critical points of the action functional

$$I(q) = \int_{-\infty}^{\infty} L(q(t), \dot{q}(t), t) dt$$

on a suitable space Ω of curves $q: \mathbb{R} \rightarrow M$ with $q(\pm\infty) = 0$.

Suppose that Ω has non-trivial topology, so that there exists a non-trivial critical level $I = c$ corresponding to a minimax or a minimum of I . Then there exist approximate critical points, that is, a sequence $\{q_n\}$, $q_n \in \Omega$ (called a *Palais–Smale sequence*) such that $I'(q_n) \rightarrow 0$ and $I(q_n) \rightarrow c$ as $n \rightarrow \infty$ (here I' is the variation of I). In the problem under consideration the *Palais–Smale condition* – that the Palais–Smale sequence have a converging subsequence – usually does not hold. However, it turns out that there exists a subsequence (which we again denote by $\{q_n\}$) and motions h_1, \dots, h_k homoclinic to 0 with $\sum_{i=1}^k I(h_i) = c$ such that

$$q_n - \sum_{i=1}^k h_i(t - s_{in}) \rightarrow 0 \tag{4.17}$$

for some instants s_{kn} such that $|s_{in} - s_{jn}| \rightarrow \infty$ as $n \rightarrow \infty$ for $i \neq j$. (We assume that M is embedded in \mathbb{R}^N for some N , so that the sum in (4.17)

⁵ In contrast to *heteroclinic* motions, which are asymptotic to different equilibria as $t \rightarrow -\infty$ and $t \rightarrow +\infty$.

is well defined.) Thus, q_n is close to a combination of k homoclinic motions separated in time.

For a critical level c such that there are no other critical levels c_j with $\sum c_j = c$, the sequence q_n (possibly shifted in time) converges to a homoclinic motion h with $I(h) = c$. Generally speaking, no other homoclinic motions are obtained even for a rich topology of the space Ω .

However, if a certain condition (*) holds, which, informally speaking, is that there be not too many homoclinic motions (say, countably many), then, as shown by Séré (see [539] and the references therein), a certain variant of the Palais–Smale condition holds. This implies the existence of at least one homoclinic motion h on the level $I = c$ (which we call *primary*), and if this motion is unique (up to a shift in time), then also the existence of infinitely many *secondary* homoclinic motions close to

$$\sum_{j=1}^l h(t - s_j),$$

where l is arbitrary and the s_j that are multiples of the period can be chosen arbitrarily under the condition that the differences $s_i - s_j$ be sufficiently large for $i \neq j$. Thus, the (secondary) homoclinic motions are close to chains of shifts of the primary homoclinic motion separated in time. The value of the action functional on a secondary homoclinic motion is close to lc .

This theory also considers the general case where there are several minimax levels $I = c_i$, and on each of them there are several homoclinic motions with geometrically distinct trajectories (we call these motions primary). It is claimed that there exist infinitely many secondary homoclinic motions close to chains of primary homoclinic motions separated in time [539].

At the intuitive level, condition (*) means that the system is non-integrable. Indeed, for integrable systems homoclinic motions form families, so that there are always continually many such motions. For example, for autonomous systems (which have the energy integral) the homoclinic motions form the family obtained from a single motion by shifts in time, so that condition (*) does not hold. For autonomous systems there also exist results similar to those described above, but the assumptions involved become more technically complicated (see, for example, [134] and the references therein).

If the primary homoclinic motions are transversal⁶, then the existence of infinitely many homoclinic motions close to chains of primary homoclinic motions follows from the results of Poincaré and Birkhoff. Thus, Séré’s result can be regarded as a generalization of this theory to the non-transversal case. Using the same method one can find chaotic motions close to chains of homoclinic motions [539]. To verify condition (*) in the case where the system

⁶ A motion of the system homoclinic to an equilibrium is said to be *transversal* if its trajectory in the extended phase space is the line of transversal intersection of the stable and the unstable manifolds of this equilibrium.

differs by a small perturbation from a system with known behaviour one can use the Poincaré–Mel’nikov method (cf. § 7.2).

The theory described above becomes simpler and more powerful in the case where the primary homoclinic motions are minimum points of the action functional (for example, if M is a multiply connected manifold, a torus, say); see, for example, [197] and the references therein. Heteroclinic doubly asymptotic motions close to chains of doubly asymptotic motions were also constructed in that paper. In the case of a minimum of the action the theory becomes close to Mather’s results [416] in the multidimensional Aubry–Mather theory (see also § 6.3.7). Actually, here Mather’s theory is more powerful, since it deals with motions homoclinic and heteroclinic to Aubry–Mather sets, not just to hyperbolic equilibria.

Integrable Systems and Integration Methods

5.1 Brief Survey of Various Approaches to Integrability of Hamiltonian Systems

Differential equations, including Hamilton's equations, are customarily divided into integrable and non-integrable ones. "When, however, one attempts to formulate a precise definition of integrability, many possibilities appear, each with a certain intrinsic theoretic interest."¹ In this section we briefly list various approaches to integrability of Hamiltonian systems, "... not forgetting the dictum of Poincaré, that a system of differential equations is only more or less integrable"².

5.1.1 Quadratures

Integration by quadratures of a system of differential equations in \mathbb{R}^n is finding its solutions using finitely many "algebraic" operations (including taking inverse functions) and "quadratures", which means calculation of the integrals of known functions. The following assertion relates the integration of a Hamiltonian system by quadratures to the existence of sufficiently many first integrals of it.

Theorem 5.1 ([354]). *Let \mathbb{R}^{2n} be a symplectic manifold with the standard symplectic structure. Suppose that a Hamiltonian system with Hamiltonian $H: \mathbb{R}^{2n} \times \mathbb{R}\{t\} \rightarrow \mathbb{R}$ has n first integrals $F_1, \dots, F_n: \mathbb{R}^{2n} \times \mathbb{R}\{t\} \rightarrow \mathbb{R}$ (that is, $F'_t + \{F, H\} = 0$) such that $\{F_i, F_j\} = \sum c_{ij}^k F_k$, where $c_{ij}^k = \text{const}$. If*

- 1) *the differentials $d_x F_1, \dots, d_x F_n$ are independent on the set*

$$M_f = \{(x, t) \in \mathbb{R}^{2n} \times \mathbb{R}: F_i(x, t) = f_i, 1 \leq i \leq n\},$$
- 2) $\sum c_{ij}^k f_k = 0$ *for all $i, j = 1, \dots, n$,*

¹ G. D. Birkhoff, *Dynamical Systems*, AMS, 1927.

² *Ibid.*

3) the Lie algebra \mathcal{A} of linear combinations $\sum \lambda_s F_s$, $\lambda_s \in \mathbb{R}$, is soluble, then the solutions of the Hamiltonian system $\dot{x} = IdH$ lying on M_f can be found by quadratures.

Corollary 5.1. *If a Hamiltonian system with n degrees of freedom has n independent integrals in involution (the algebra \mathcal{A} is commutative), then the system can be integrated by quadratures.*

This assertion was first proved by Bour for autonomous canonical equations and then was generalized to the non-autonomous case by Liouville.

Suppose that the functions H and F_i are independent of time. Then H is also a first integral, say, $H = F_1$. The theorem on integrability by quadratures is of course valid also in this case; moreover, the condition $\{F_1, F_i\} = 0$ can be replaced by the weaker condition $\{F_1, F_i\} = c_{1i}^i F_1$, $1 \leq i \leq n$.

The proof of Theorem 5.1 is based on the following result of Lie.

Theorem 5.2. *Suppose that n vector fields X_1, \dots, X_n are linearly independent at each point of a domain $U \subset \mathbb{R}^n\{x\}$, generate a soluble Lie algebra with respect to the operation of commutation, and $[X_1, X_i] = \lambda_i X_1$. Then the differential equation $\dot{x} = X_1(x)$ can be integrated by quadratures in the domain U .*

◁ We prove this assertion in the simplest case $n = 2$. In the general case the proof is similar (see [167]). The equation $\dot{x} = X_1(x)$, $x \in U$, will be integrated if we succeed to find a first integral $F(x)$ of it such that $dF(x) \neq 0$ everywhere in the domain U . Since $X_1(x) \neq 0$, $x \in U$, such a function does exist (at least locally). If $X_1(F) = 0$, then $X_2(F)$ is again an integral, since $X_1(X_2(F)) = X_2(X_1(F)) + \lambda_2 X_1(F) = 0$. It is obvious that locally $X_2(F) = f(F)$, where $f(\cdot)$ is some smooth function of one variable, $f \neq 0$. We set

$$G(F) = \int_{F_0}^F \frac{dz}{f(z)}.$$

Since $X_1(G) = 0$ and $X_2(F) = dG(X_2(F)) = X_2(F)/f(F) = 1$, there exists a solution of the system of equations

$$X_1(F) = a_{11} \frac{\partial F}{\partial x_1} + a_{12} \frac{\partial F}{\partial x_2} = 0, \quad X_2(F) = a_{21} \frac{\partial F}{\partial x_1} + a_{22} \frac{\partial F}{\partial x_2} = 1.$$

Solving this system with respect to F'_{x_1} and F'_{x_2} we find the function F using an additional integration. Since $X_2(F) = 1$, we have $dF \neq 0$. ▷

◁ *Proof of Theorem 5.1 in the autonomous case.* We consider the n Hamiltonian fields $I dF_i$. According to conditions 1), 2), these fields are tangent to the manifold M_f and independent everywhere on M_f . Since $\{F_i, F_j\} = \sum c_{ij}^k F^k$, we have $[I dF_i, I dF_j] = \sum c_{ij}^k I dF_k$. Consequently, the tangent fields $I dF_i$ generate a soluble algebra, and $[I dH, I dF_i] = \lambda_i I dH$ (where $\lambda_i = c_{1i}^1 = \text{const}$). Theorem 5.1 now follows from Lie's Theorem 5.2. ▷

Remark 5.1. Theorem 5.2 in turn can be derived from Theorem 5.1. For that consider the n functions $F_i(x, y) = y \cdot X_i(x)$ defined in $U \times \mathbb{R}^n$. If $[X_i, X_j] = \sum c_{ij}^k X_k$, then clearly $\{F_i, F_j\} = \sum c_{ij}^k F_k$. The manifold $M_0 = \{(x, y) : F_1 = \dots = F_n = 0\} = \{(x, y) : y = 0\}$ is invariant for the Hamiltonian system with Hamiltonian function F_1 . Applying the autonomous variant of Theorem 5.1 on M_0 and identifying M_0 with U we obtain the conclusion of Theorem 5.2.

The non-autonomous theorem can be derived from the autonomous one using the following method. Hamilton's equations

$$\dot{x} = H'_y, \quad \dot{y} = -H'_x; \quad H = H(x, y, t)$$

can be represented as the following canonical system in the extended space of variables x, y, h, t with the Hamiltonian function $K(x, y, h, t) = H(x, y, t) - h$:

$$\dot{x} = K'_y, \quad \dot{y} = -K'_x, \quad \dot{h} = K'_t, \quad \dot{t} = -K'_h.$$

If we denote by $\{, \}_*$ the Poisson bracket in the extended symplectic space $\mathbb{R}^{2n}\{x, y\} \times \mathbb{R}^2\{h, t\}$, then

$$\begin{aligned} \{F_i(x, y, t), F_j(x, y, t)\}_* &= \{F_i, F_j\} = \sum c_{ij}^k F_k, \\ \{F_i(x, y, t), K(x, y, h, t)\}_* &= \{F_i, H - h\} = \frac{\partial F_i}{\partial t} + \{F_i, H\} = 0. \end{aligned}$$

It remains to observe that the functions F_1, \dots, F_n , and K are independent in the sense that their differentials are independent at each point of the $(n + 1)$ -dimensional integral manifold

$$\{F_1 = f_1, \dots, F_n = f_n, K = 0\}$$

in the extended phase space. The last condition is equivalent to condition 1) of Theorem 5.1.

Example 5.1. Consider the problem of the motion along a straight line of three points attracting one another with a force inversely proportional to the cube of the distance between them. Let m_i be the masses, x_i the coordinates, and $p_i = m_i \dot{x}_i$ the momenta of the points. The potential energy of their interaction is

$$U = \sum_{i < j} \frac{a_{ij}}{(x_i - x_j)^2}, \quad a_{i,j} = \text{const.}$$

The functions $F_1 = \sum p_i^2/2m_i + U$, $F_2 = \sum p_i x_i$, and $F_3 = \sum p_i$ are independent and $\{F_1, F_3\} = 0$, $\{F_2, F_3\} = F_3$, $\{F_1, F_2\} = 2F_1$. Since the corresponding algebra \mathcal{A} is soluble, the motions lying on the zero levels of the total energy and the momentum can be found by quadratures. This possibility can be easily realized directly. If the points have equal masses, and the coefficients a_{ij} ($i < j$) are all equal, then the equations of motion can be integrated by quadratures globally (see Example 5.8). Note that in this example the potential U can be replaced by an arbitrary homogeneous function of degree -2 . △

5.1.2 Complete Integrability

Let M be a symplectic manifold and let F_1, \dots, F_n be functions on M that are independent at each point and generate a finite-dimensional subalgebra of the Lie algebra $C^\infty(M)$ (so that $\{F_i, F_j\} = \sum c_{ij}^k F_k$, $c_{ij}^k = \text{const}$). At each point $x \in M$, where the functions F_1, \dots, F_n are independent, the vectors $I dF_i$ generate an n -dimensional vector subspace $\Pi(x)$ of $T_x M$. The distribution of the planes $\Pi(x)$ is involutive (if $X(x), Y(x) \in \Pi$, then $[X, Y](x) \in \Pi$). Consequently, by Frobenius' theorem through each point $x \in M$ there passes a maximal integral manifold N_x of the distribution Π . These manifolds can be immersed into M in quite a complicated way; in particular, they may not be closed. If $n = \dim M/2$, then among the integral manifolds of the distribution Π there are the closed surfaces $M_f = \{x \in M: F_i(x) = f_i, \sum c_{ij}^k f_k = 0\}$. If $x \in M_f$, then N_x coincides with one of the connected components of the manifold M_f . In the special case where the functions F_1, \dots, F_n commute pairwise, almost the whole of M is "foliated" by the closed integral manifolds M_f .

Theorem 5.3. *Suppose that the smooth functions $F_1, \dots, F_n: M \rightarrow \mathbb{R}$ are pairwise in involution and $\dim M = 2n$. If*

- 1) *their differentials are linearly independent at each point of M_f ,*
- 2) *the Hamiltonian fields $I dF_i$ ($1 \leq i \leq n$) are complete on M_f ,*

then

- a) *each connected component of M_f is diffeomorphic to $\mathbb{T}^k \times \mathbb{R}^{n-k}$,*
- b) *on $\mathbb{T}^k \times \mathbb{R}^{n-k}$ there exist coordinates $\varphi_1, \dots, \varphi_k \bmod 2\pi, y_1, \dots, y_{n-k}$ in which Hamilton's equation $\dot{x} = I dF_i$ on M_f has the form*

$$\dot{\varphi}_m = \omega_{mi}, \quad \dot{y}_s = c_{si} \quad (\omega, c = \text{const}).$$

The Hamiltonian system with Hamiltonian function F_i for each $i = 1, \dots, n$ is said to be *completely integrable*. In the case of compact M_f Theorem 5.3 was first proved in [72].

◁ We outline the proof of this theorem. Consider the n one-parameter groups $\{g_i^{t_i}\}$, $t_i \in \mathbb{R}$, which are the phase flows of the n Hamiltonian fields $I dF_i$. By condition 2), the value $g_i^{t_i}(x)$, $x \in M_f$, is defined for all t_i . The groups g_i and g_j commute, since the vector fields $I dF_i$ and $I dF_j$ commute on M_f . Consequently, the following action of the abelian group $\mathbb{R}^n = \{t_1, \dots, t_n\}$ is defined on M_f :

$$g^t(x) = g_1^{t_1} \cdots g_n^{t_n}(x), \quad t = (t_1, \dots, t_n).$$

One can deduce from condition 1) and the connectedness of M_f that the group \mathbb{R}^n acts on M_f freely and transitively. Consequently, M_f is diffeomorphic to the quotient manifold \mathbb{R}^n/Γ , where Γ is the isotropy group of the action of

\mathbb{R}^n (which consists of the points $t \in \mathbb{R}^n$ such that $g^t x = x$). Since the tangent fields $I dF_i$ are independent at each point of the manifold M_f , Γ is a discrete subgroup of \mathbb{R}^n isomorphic to \mathbb{Z}^k ($0 \leq k \leq n$). Thus,

$$M_f \simeq \mathbb{R}^n / \mathbb{Z}^k = \mathbb{T}^k \times \mathbb{R}^{n-k}.$$

The uniformly varying “global” coordinates $\varphi \bmod 2\pi$, y can be linearly expressed in t_1, \dots, t_n . All the details of the proof can be found in [10]. \square

Remark 5.2. If the algebra of integrals \mathcal{A} is non-commutative, then the closed invariant integral levels M_f are diffeomorphic to the quotient of the simply connected group of the algebra \mathcal{A} by some discrete subgroup. Realization of this general remark is held up by the unsolved problem of classification of Lie groups and algebras.

In the theory and practice of completely integrable Hamiltonian systems the most interesting case is where the set M_f is compact. Then $k = n$ and consequently $M_f \simeq \mathbb{T}^n$. The uniform motion on the torus $\mathbb{T}^n = \{\varphi_1, \dots, \varphi_n \bmod 2\pi\}$ according to the law $\varphi_i = \varphi_i^0 + \omega_i t$ ($1 \leq i \leq n$) is called *conditionally* (or *quasi-*) *periodic*. The numbers $\omega_1, \dots, \omega_n$ are its *frequencies*. The torus with frequencies $\omega_1, \dots, \omega_n$ is called *non-resonant* if the equality $\sum k_i \omega_i = 0$ with integer k_i implies that $k_i = 0$ for all i . The phase trajectories are everywhere dense on non-resonant tori. This assertion is a simple consequence of the following general result due to H. Weyl.

Theorem 5.4. *Let $f: \mathbb{T}^n \rightarrow \mathbb{R}$ be a Riemann-integrable function and let $\omega_1, \dots, \omega_n$ be rationally independent numbers. Then for every point $\varphi^0 \in \mathbb{T}^n$ the limit*

$$\lim_{s \rightarrow \infty} \frac{1}{s} \int_0^s f(\omega t + \varphi^0) dt$$

exists and is equal to

$$\frac{1}{(2\pi)^n} \int_{\mathbb{T}^n} f(\varphi) d\varphi_1 \dots d\varphi_n.$$

In particular, suppose that f is the characteristic function of a Jordan-measurable domain D on \mathbb{T}^n . Applying Theorem 5.4 to the function f we obtain the following assertion: the average share of the time that the phase trajectory sojourns in the domain D is proportional to the measure of D . This fact characterizes the property of the uniform distribution of the trajectories on non-resonant tori. If the torus is *resonant*, then the phase trajectories fill tori of smaller dimension.

5.1.3 Normal Forms

We consider a Hamiltonian system

$$\dot{z} = I dH(z), \quad z = (p, q) \in \mathbb{R}^{2n},$$

in a neighbourhood of the point $z = 0$. Suppose that H is a real-analytic function represented by a converging power series in z starting from the terms of the second order: $H = \sum_{k \geq 2} H_k$. The point $z = 0$ is obviously an equilibrium position.

The eigenvalues of the linearized system $\dot{z} = I dH_2$ can be of four types: real pairs $(a, -a)$, $a \neq 0$; purely imaginary pairs $(ib, -ib)$, $b \neq 0$; quadruplets $(\pm a \pm ib)$, $a \neq 0$, $b \neq 0$; and zero as a multiple eigenvalue (see §8.2.3). In the first and third cases the equilibrium $z = 0$ is of course unstable. We consider the case where the eigenvalues of the linearized system are purely imaginary and distinct. One can show that then there exists a linear canonical transformation of coordinates $p, q \mapsto x, y$ reducing the quadratic form H_2 to

$$\frac{1}{2} \sum_s \alpha_s (x_s^2 + y_s^2).$$

The eigenvalues are exactly $\pm i\alpha_1, \dots, \pm i\alpha_n$.

Theorem 5.5 (Birkhoff). *If $\alpha_1, \dots, \alpha_n$ are independent over the field of rationals, then there exists a formal canonical change of variables $x, y \mapsto \xi, \eta$ given by formal power series*

$$x = u(\xi, \eta) = \xi + \dots, \quad y = v(\xi, \eta) = \eta + \dots \quad (5.1)$$

that transforms $H(x, y)$ into a Hamiltonian $K(\rho)$ which is a formal power series in the $\rho_s = \xi_s^2 + \eta_s^2$.

Here the quadratic form H_2 is assumed to be already normalized. If the series (5.1) converge, then the equations with Hamiltonian function H can be easily integrated. Indeed, the functions ρ_1, \dots, ρ_n , which are converging power series in x, y , form a complete set of independent integrals in involution. The canonical equations

$$\dot{\xi}_s = \Omega_s \eta_s, \quad \dot{\eta}_s = -\Omega_s \xi_s, \quad \Omega_s = 2K'_{\rho_s},$$

imply that $\xi_s(t)$ and $\eta_s(t)$ are linear combinations of $\sin \Omega_s t$ and $\cos \Omega_s t$. Consequently, the original coordinates x and y are *conditionally* (or *quasi*-) *periodic functions* of time with frequencies $\Omega_1, \dots, \Omega_n$.³ In particular, the equilibrium $z = 0$ is stable.

³ A function $g: \mathbb{R}\{t\} \rightarrow \mathbb{R}$ is called a *conditionally periodic* function with frequencies $\omega_1, \dots, \omega_n$ if $g(t) = f(\omega_1 t, \dots, \omega_n t)$, where $f: \mathbb{T}^n \rightarrow \mathbb{R}$.

Remark 5.3. The hypothesis of Birkhoff’s theorem still does not guarantee the Lyapunov stability of the equilibrium of the Hamiltonian system. In the infinitely differentiable case a counterexample is given in [215]. For the present there is no counterexample for analytic Hamiltonian systems.

Theorem 5.6 (see [523]). *If the system with Hamiltonian $H = \sum_{k \geq 2} H_k$ has n analytic integrals in involution*

$$G_m = \frac{1}{2} \sum \varkappa_{ms} (x_s^2 + y_s^2) + \sum_{k \geq 2} G_{mk}$$

and $\det (\varkappa_{ms}) \neq 0$, then the Birkhoff transformation (5.1) converges.

This result shows why we (following Birkhoff) say that a Hamiltonian system is integrable if the Birkhoff transformation converges. Postponing the discussion of convergence until Ch.7 we mention that as a rule Birkhoff’s series diverge.

Theorem 5.5 admits a generalization to the case where the numbers $\alpha = (\alpha_1, \dots, \alpha_n)$ are rationally dependent. We consider all the integer vectors $j = (j_1, \dots, j_n)$ such that $\langle j, \alpha \rangle = \sum j_s \alpha_s = 0$. They form a free abelian group Γ of some rank r . If the numbers α_s are independent, then clearly $r = 0$.

We perform some formal canonical change of variables $x, y \mapsto \xi, \eta$ of the form (5.1). In the new variable ξ, η the Hamiltonian $H(x, y)$ is represented by some formal power series $K(\xi, \eta)$. We pass to the complex variables $\zeta_s = \xi_s + i\eta_s, \bar{\zeta}_s = \xi_s - i\eta_s$ and expand K in a series in the products

$$\zeta^k \bar{\zeta}^l = \prod_{s=1}^n \zeta_s^{k_s} \bar{\zeta}_s^{l_s}.$$

Definition 5.1. The formal series $K(\xi, \eta)$ is in *normal form* if its expansion contains only the terms $\zeta^k \bar{\zeta}^l$ with $(k - l) \in \Gamma$.

In particular, if $\alpha_1, \dots, \alpha_n$ are independent, then a normal form of the Hamiltonian has only terms of the form

$$\zeta^k \bar{\zeta}^k = (\xi_1^2 + \eta_1^2)^{k_1} \dots (\xi_n^2 + \eta_n^2)^{k_n}.$$

Proposition 5.1. *The series $K(\xi, \eta)$ is in normal form if and only if $D(K) = 0$, where*

$$D = \sum_{s=1}^n \alpha_s \left(\xi_s \frac{\partial}{\partial \eta_s} - \eta_s \frac{\partial}{\partial \xi_s} \right).$$

The proof is easily derived from the formula

$$D(\zeta^k \bar{\zeta}^l) = i \langle \alpha, k - l \rangle (\zeta^k \bar{\zeta}^l).$$

Theorem 5.7. *There exists a formal canonical transformation of the form (5.1) such that the original Hamiltonian $H(x, y)$ is transformed to a normal form, that is, such that $D(K) = 0$.*

The proof can be found in [36]. For $\Gamma = \{0\}$ this theorem coincides with Birkhoff's theorem.

We now show that in the case under consideration there exist $n - r$ commuting independent formal integrals of the form

$$G = \frac{1}{2} \sum \beta_s (\xi_s^2 + \eta_s^2),$$

where the vector $\beta = (\beta_1, \dots, \beta_n)$ is orthogonal to all the vectors in the group Γ . Indeed,

$$\frac{d}{dt} G = \sum \beta_s \left(\xi_s \frac{\partial K}{\partial \eta_s} - \eta_s \frac{\partial K}{\partial \xi_s} \right) = 0,$$

if $\beta \perp \Gamma$. Since $\text{rank } \Gamma = r$, we can find $n - r$ such linearly independent vectors β .

Example 5.2. We apply these considerations to the Hamiltonian system with Hamiltonian function

$$H = \frac{1}{2} \left(y_1^2 + y_2^2 + x_1^2 + x_2^2 + 2x_1^2 x_2 - \frac{2}{3} x_2^3 \right),$$

which was studied in detail by Hénon and Heiles using numerical computations. In this problem, $n = 2$ and $\alpha_1 = \alpha_2 = 1$. The group Γ is defined by the equality $j_1 + j_2 = 0$, and $\dim \Gamma = 1$. To obtain an integral independent of H we can set $\beta_1 = \beta_2 = 1$. Then $G = (\xi_1^2 + \eta_1^2 + \xi_2^2 + \eta_2^2)/2$. If H is transformed to a normal form by Theorem 5.7, then

$$K = \frac{1}{2} (\xi_1^2 + \eta_1^2 + \xi_2^2 + \eta_2^2) + \dots$$

begins with the same terms as G . One can show by direct calculations (using the terms of degree ≥ 2) that the functions K and G are indeed independent. The discussion of the numerical results of Hénon and Heiles in connection with the construction of the formal integral can be found in the works of Gustavson [271] and Moser [36]. \triangle

Transformation to a normal form can be carried out not only in a neighbourhood of an equilibrium position, but also, for example, in a neighbourhood of a periodic trajectory. All what was said above, with necessary alterations, is also valid in this case. In the next chapter we shall consider various variants of perturbation theory, in which the Hamiltonian functions are also transformed to a certain "normal form". As in the case of the Birkhoff normal forms, the series in perturbation theory are in general divergent.

5.2 Completely Integrable Systems

In this section we continue the study of Hamiltonian systems that have a complete set of independent integrals in involution.

5.2.1 Action–Angle Variables

Theorem 5.8. *Suppose that the hypotheses of Theorem 5.3 hold and the integral manifold M_f is connected and compact. Then*

- 1) *a small neighbourhood of the manifold M_f in the symplectic manifold M is diffeomorphic to the direct product $D \times \mathbb{T}^n$, where D is a small domain in \mathbb{R}^n ,*
- 2) *in $D \times \mathbb{T}^n$ there exist symplectic coordinates $I, \varphi \bmod 2\pi$ ($I \in D, \varphi \in \mathbb{T}^n$) such that in these variables the functions F_1, \dots, F_n depend only on I , and the symplectic structure has the form $dI \wedge d\varphi$.*

In particular, in the variables $I, \varphi \bmod 2\pi$ the Hamiltonian function of the completely integrable system with invariant tori takes the form $H = H(I)$. Then

$$\dot{I} = -H'_\varphi = 0, \quad \dot{\varphi} = H'_I = \omega(I). \quad (5.2)$$

Consequently, $I(t) = I_0$ and $\omega(I) = \omega(I_0)$. The variables I “numbering” the invariant tori in $D \times \mathbb{T}^n$ are called “*action variables*” and the uniformly changing coordinates φ are called “*angle variables*”.

Example 5.3. Consider a Hamiltonian system with one degree of freedom and with Hamiltonian function $H: \mathbb{R}^2\{p, q\} \rightarrow \mathbb{R}$. Let h_0 be a regular value of the function H such that its level line $H = h_0$ is bounded. Consequently, for the values of h close to h_0 the levels $M_h = \{H = h\}$ are diffeomorphic to one-dimensional tori (circles). On each M_h there obviously exists an angle coordinate $\varphi \bmod 2\pi$ uniformly changing with time. In this problem the conjugate action variable is $\Pi(h)/2\pi$, where $\Pi(h)$ is the area of the domain in \mathbb{R}^2 bounded by the curve M_h . This is a consequence of the following easily verifiable formula:

$$dp \wedge dq = \frac{1}{2\pi} d\Pi \wedge d\varphi.$$

By Green’s formula,

$$I(h) = \frac{1}{2\pi} \iint_{H \leq h} dp \wedge dq = \frac{1}{2\pi} \oint_{H=h} p dq.$$

Therefore the variable I has the dimension of action (according to Hamilton), which explains the name.

If $H = (a^2 p^2 + b^2 q^2)/2$, then M_h is an ellipse bounding the area $\Pi(h) = 2\pi h/ab = 2\pi h/\omega$, where $\omega = ab$. Consequently, for the harmonic oscillator the action variable is the ratio of the energy to the frequency of oscillations. The angle variable φ is of course the phase of the harmonic oscillations. \triangle

◁ *Proof of Theorem 5.8.* In a neighbourhood of the torus $M_f \simeq \mathbb{T}^n$, for coordinates we can take the functions $I_i = F_i$ and the angles $\varphi_i \bmod 2\pi$ given by Theorem 5.3. Since the dF_i are linearly independent, the functions I_i, φ_i ($1 \leq i \leq n$) define a diffeomorphism of a neighbourhood of M_f onto the direct product $D \times \mathbb{T}^n$ (where D is a domain in $\mathbb{R}^n = \{I\}$). We introduce the non-singular matrix of Poisson brackets

$$\begin{pmatrix} \{I_i, I_j\} & \{I_i, \varphi_j\} \\ \{\varphi_i, I_j\} & \{\varphi_i, \varphi_j\} \end{pmatrix} = \begin{pmatrix} 0 & a_{ij} \\ -a_{ji} & b_{ij} \end{pmatrix}.$$

By Theorem 5.3 the brackets $\{I_i, \varphi_j\}$ are constant on M_f ; consequently, $a_{ij} = a_{ij}(I)$. We claim that the b_{ij} also depend only on I . Indeed, by the Jacobi identity we have

$$\{F_m, \{\varphi_i, \varphi_j\}\} + \{\varphi_i, \{\varphi_j, F_m\}\} + \{\varphi_j, \{F_m, \varphi_i\}\} = 0.$$

The brackets $\{F_m, b_{ij}\} = \alpha_{ij}^m$ are independent of φ . On the other hand,

$$\alpha_{ij}^m = \sum_s \frac{\partial b_{ij}}{\partial \varphi_s} \{F_m, \varphi_s\} = \sum_s \frac{\partial b_{ij}}{\partial \varphi_s} a_{ms}.$$

From this we find the $\partial b_{ij}/\partial \varphi_s$ as function of I only, since $\det(a_{ms}) \neq 0$. Consequently, $b_{ij} = \{\varphi_i, \varphi_j\} = \sum f_{ij}^s(I)\varphi_s + g_{ij}(I)$. Since the $d\varphi_i$ are single-valued 1-forms near M_f , we have $f_{ij}^s \equiv 0$.

We perform a change of variables $I_s = I_s(J_1, \dots, J_n)$ so that $\{J_i, \varphi_j\} = \delta_{ij}$. For that we need to solve the system of equations

$$a_{ij}(I) = \{I_i, \varphi_j\} = \sum \frac{\partial I_i}{\partial J_s} \delta_{sj} = \frac{\partial I_i}{\partial J_i}.$$

For this system the solubility condition

$$\frac{\partial a_{ij}}{\partial J_s} = \frac{\partial a_{is}}{\partial J_i} \Leftrightarrow \sum_k \frac{\partial a_{ij}}{\partial I_k} a_{ks} = \sum_k \frac{\partial a_{is}}{\partial I_k} a_{kj}$$

follows from the Jacobi identity applied to the functions I_i, φ_j , and φ_k .

If the variables φ_i do not commute, then we must pass to new angle coordinates $\psi_i \bmod 2\pi$ by a shift $\varphi_i = \psi_i + f_i(J)$. The functions f_i are determined by the following system of equations:

$$b_{ij} = \frac{\partial f_i}{\partial J_j} - \frac{\partial f_j}{\partial J_i} \quad (1 \leq i, j \leq n).$$

The condition for its local solubility is that the 2-form $\sum b_{ij} dI_i \wedge dI_j$ be closed. The closedness of this form follows from the closedness of the original symplectic structure. Thus, the proof of the existence of symplectic action-angle variables $J, \psi \bmod 2\pi$ is complete. \triangleright

Remark 5.4. Let p, q be symplectic coordinates in \mathbb{R}^{2n} and let $\gamma_1, \dots, \gamma_n$ be fundamental cycles on M_f depending continuously on the constants $f = (f_1, \dots, f_n)$. Since the form $p dq - I d\varphi$ is closed, the difference

$$\oint_{\gamma_s} p dq - \oint_{\gamma_s} I d\varphi = \oint_{\gamma_s} p dq - 2\pi I_s$$

is constant. Consequently,

$$I_s = \frac{1}{2\pi} \oint_{\gamma_s} p dq \quad (1 \leq s \leq n), \quad (5.3)$$

since the action variables themselves are defined up to an additive constant. Formulae (5.3) are most effective in the analysis of systems with separated variables (see § 5.3).

A Hamiltonian system with Hamiltonian function $H(I)$ is said to be *non-degenerate* (in a domain $D \times \mathbb{T}^n$) if the Jacobian

$$\frac{\partial \omega}{\partial I} = \det \left(\frac{\partial^2 H}{\partial I^2} \right)$$

is non-zero at each point of the domain D . In this case almost all (in the sense of Lebesgue measure) invariant tori are non-resonant, while the resonant tori are everywhere dense in $D \times \mathbb{T}^n$.

The system is said to be *properly degenerate* if

$$\frac{\partial \omega}{\partial I} \equiv 0.$$

Degeneracy can be caused by the fact that the number of first integrals defined on the entire phase space is greater than n (but of course not all of them are in involution). Thus, for example, in the Euler problem of the free rotation of a rigid body, which has three degrees of freedom, there exist four independent first integrals. Their common levels foliate the three-dimensional invariant tori by two-dimensional tori. This situation is described by a generalization of Theorem 5.8. Let F_1, \dots, F_{n+k} denote independent first integrals of a Hamiltonian system with Hamiltonian H and let, as before, $M_f = \{x \in M: F_i(x) = f_i, 1 \leq i \leq n+k\}$. We assume that M_f is connected and compact.

Theorem 5.9 (Nekhoroshev [471]). *Suppose that the first $n-k$ of the functions F_i are in involution with all the functions F_i . Then*

1) *the level sets M_f are diffeomorphic to $(n-k)$ -dimensional tori,*

- 2) in a neighbourhood of each level set M_f there exist symplectic coordinates $I, p, \varphi \bmod 2\pi, q$ such that

$$I_s = I_s(F_1, \dots, F_{n-k}), \quad 1 \leq s \leq n - k,$$

and p, q depend on all the F_i . The symplecticity of the coordinates means that $\omega = \sum dp_j \wedge dq_j + \sum dI_s \wedge d\varphi_s, \quad j = 1, \dots, k, \quad s = 1, \dots, n - k.$

The symplectic coordinates in Theorem 5.9 may be called *generalized action-angle variables*.

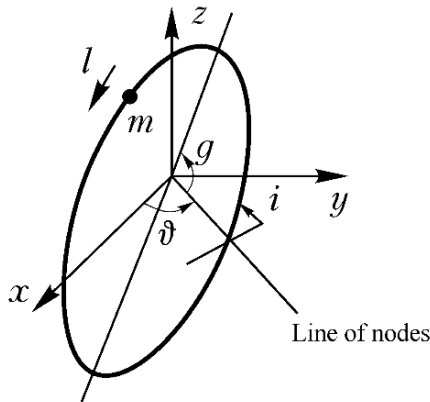

Fig. 5.1. The Delaunay elements

Example 5.4. Consider Kepler’s problem in three-dimensional space. This Hamiltonian system with three degrees of freedom has four $(3 + 1)$ integrals: H (the total energy), M^2 (the square of the magnitude of the angular momentum), M_y , and M_z (the projections of the angular momentum onto the y - and z -axes). The functions H and M^2 (two of them, $3 - 1$) commute with all the integrals, which fact allows us to apply Theorem 5.9. The generalized action-angle variables of Kepler’s problem are usually denoted by $L, G, \Theta, l, g,$ and ϑ and are called the *Delaunay elements* (see Fig. 5.1). If $a, e,$ and i denote the major semiaxis, eccentricity, and inclination of an elliptic orbit, then

$$L = \sqrt{\gamma a}, \quad G = \sqrt{\gamma a(1 - e^2)}, \quad \Theta = G \cos i.$$

Next, ϑ is the longitude of the ascending node, $g + \vartheta$ the longitude of the perihelion, and l the mean anomaly. In these variables, $H = -\gamma^2/2L^2, \quad M^2 = G^2,$ and $M_z = \Theta.$ The expression of M_y in terms of the Delaunay elements is more cumbersome. The details can be found in [20]. In this problem, for the variables I, φ we have the elements $L, G, l, g,$ and for the variables p, q the elements $\Theta, \vartheta.$ △

In conclusion we discuss a question relating to the averaging over time in integrable Hamiltonian systems. Let $f: D \times \mathbb{T}^n \rightarrow \mathbb{R}$ be some continuous function. Consider its behaviour on solutions of the Hamiltonian system (5.2). We form the average over the torus

$$\lambda(I) = (2\pi)^{-n} \int_0^{2\pi} \dots \int_0^{2\pi} f(I, \varphi) d\varphi_1 \dots d\varphi_n$$

and the time average

$$g(I, \varphi) = \lim_{s \rightarrow \infty} \frac{1}{s} \int_0^s f(I, \omega t + \varphi) dt.$$

By Theorem 5.4 the limit always exists. But if the frequencies $\omega(I) = (\omega_1(I), \dots, \omega_n(I))$ are rationally dependent, then the average depends on the initial phase φ . Here we have

$$(2\pi)^{-n} \int_{\mathbb{T}^n} g(I, \varphi) d\varphi = \lambda(I)$$

for all $I \in D$. On the non-resonant tori we have $g(I, \varphi) = \lambda(I)$ for all $\varphi \in \mathbb{T}^n$. Consequently, the time average $g(I, \varphi)$ is in general a discontinuous function in the domain $D \times \mathbb{T}^n$.

Proposition 5.2. *If $I = I_0$ is a non-resonant torus, then*

$$\lim_{I \rightarrow I_0} g(I, \varphi) = \lambda(I_0)$$

uniformly in $\varphi \in \mathbb{T}^n$

Thus, the function $g(I, \varphi)$ resembles the classical example of the Riemann function, which is continuous at the irrational points, and discontinuous at the rational points. The proof of Proposition 5.2 is contained in [27].

5.2.2 Non-Commutative Sets of Integrals

Let M be a symplectic manifold of dimension $2n$ and let $F_1, \dots, F_k: M \rightarrow \mathbb{R}$ be smooth independent functions whose differentials are linearly independent almost everywhere on M . Therefore the linear span \mathcal{G} of the functions F_1, \dots, F_k over the field \mathbb{R} has dimension k . Suppose that \mathcal{G} is closed under the Poisson bracket: $\{F_i, F_j\} = \sum c_{ij}^s F_s$. Thus \mathcal{G} has the structure of a real finite-dimensional Lie algebra. We define the rank of the algebra \mathcal{G} (denoted $\text{rank } \mathcal{G}$) as the maximum rank of the matrix $(a_{ij}(F_1, \dots, F_k))$, where $a_{ij} = \{F_i, F_j\}$, over all points of M (cf. §3.2.2).

Theorem 5.10. *Suppose that the differentials dF_i are linearly independent on a level set $M_f = \{x \in M: F_i(x) = f_i, 1 \leq i \leq k\}$ and the algebra \mathcal{G} satisfies the condition*

$$2 \dim \mathcal{G} - \text{rank } \mathcal{G} = \dim M. \tag{5.4}$$

If M_f is connected and compact, then it is diffeomorphic to the l -dimensional torus \mathbb{T}^l , where $l = \frac{1}{2}(\dim M - \text{rank } \mathcal{G})$. Furthermore, if the functions F_1, \dots, F_k are first integrals of a Hamiltonian system with Hamiltonian H , then on M_f there exist angle coordinates $\varphi_1, \dots, \varphi_l \bmod 2\pi$ such that Hamilton's equations $\dot{x} = I dH(x)$ on \mathbb{T}^l take the form $\dot{\varphi}_s = \omega_s = \text{const}$.

This assertion related to Theorem 5.9 was obtained by Mishchenko and Fomenko [424]. It can be derived from the Lie–Cartan theorem (Theorem 3.16 in §3.2), by which, under the assumptions of Theorem 5.10, there exist k functions Φ_1, \dots, Φ_k of the first integrals F_1, \dots, F_k in a neighbourhood of the point $F_s = f_s$ such that

$$\{\Phi_i, \Phi_{r+i}\} = 1, \quad 1 \leq i \leq r, \quad r = \frac{1}{2} \text{rank } \mathcal{G},$$

and all the other brackets are $\{\Phi_i, \Phi_j\} = 0$. Consequently, the set $N_c = \{x \in M: \Phi_m(x) = c, 1 \leq m \leq 2r\}$ is a symplectic submanifold of M and the restrictions of the functions $\Phi_{2r+1}, \dots, \Phi_k$ to N_c form a complete set of commuting integrals. The conclusion of Theorem 5.10 now follows from Theorem 5.3.

Example 5.5. Consider the problem of the motion of a material point in a central field. The corresponding Hamiltonian system has four independent integrals: $H, M_x, M_y,$ and M_z . The functions M_x, M_y, M_z generate a Lie algebra isomorphic to $so(3)$, and the function H commutes with $M_x, M_y,$ and M_z . If the constant values of the “area integrals” M are not all equal to zero, then the rank of the matrix of the Poisson brackets (a_{ij}) is obviously equal to two. In this case equality (5.4) holds and therefore Theorem 5.10 can be applied. △

In Example 5.5, as well as in all the known cases described by Theorem 5.10, one can find a complete set of integrals in involution. This observation is not a coincidence, as shown by the following.

Theorem 5.11. *If M is compact, then under the hypotheses of Theorem 5.10 there exist $n = \dim M/2$ independent integrals Φ_1, \dots, Φ_n in involution; these functions are polynomials in F_1, \dots, F_k .*

The paper of Mishchenko and Fomenko [425], where this theorem was proved, also contains the conjecture that the condition of M being compact can be dropped. This conjecture was proved by Sadehtov in [532]. Note that

the Lie–Cartan theorem of course implies the complete integrability near the level set M_f , which is a weaker result in comparison with Theorem 5.11.

These results can be generalized to the case of an infinite-dimensional algebra of first integrals. Let F_1, \dots, F_k be almost everywhere independent integrals of a Hamiltonian system in a $2n$ -dimensional phase space M . They include the Hamiltonian function. Let $2r$ be the rank of the skew-symmetric matrix of their Poisson brackets

$$(\{F_i, F_j\}), \quad 1 \leq i, j \leq k.$$

We consider a domain of the phase space where this rank is constant. Note that the rank takes the maximum value at almost every point of M .

The inequality

$$k \leq n + r$$

is a well-known fact in symplectic geometry (see, for example, [11]). The assumption

$$k = n + r$$

is called the *condition for non-commutative integrability* of Hamilton’s equations. This condition generalizes (5.4) and has a clear meaning: it is impossible to add other independent functions to the functions F_1, \dots, F_k without raising the rank of the matrix of their Poisson brackets.

In the theory of non-commutative integration one usually considers *closed* sets of integrals: their Poisson brackets are functions of F_1, \dots, F_k . This assumption is natural from the viewpoint of Poisson’s theorem. It is easy to see that every set of first integrals can be extended to a closed set by differentiations and algebraic operations (see, for example, [18]).

For closed sets of integrals of the general form Theorem 5.10 was proved by Strel’tsov (see [236]). In [142] it was proved that a Hamiltonian system with a closed set of integrals satisfying the condition $k = n + r$ is integrable by quadratures. The idea is that under the closedness assumption one can constructively (using algebraic operations) find a complete set of commuting vector fields on the $(2n - 2r)$ -dimensional integral manifolds.

A survey of the results in the theory of non-commutative integration of Hamiltonian systems and the connections of this theory with the old results of Lie, Cartan, and Dirac can be found in the book [236].

5.2.3 Examples of Completely Integrable Systems

a) The Euler–Poisson equations

$$A\dot{\omega} = A\omega \times \omega + \mathbf{e} \times \mathbf{r}, \quad \dot{\mathbf{e}} = \mathbf{e} \times \omega$$

describing the rotation of a heavy rigid body with a fixed point contain six parameters: three eigenvalues of the inertia operator A_1, A_2, A_3 and three coordinates of the centre of mass r_1, r_2, r_3 with respect to the principal

axes. As shown in Ch. 3 (Example 3.14), the Euler–Poisson equations are Hamiltonian on the four-dimensional integral manifolds

$$M_c = \{(\boldsymbol{\omega}, \mathbf{e}) \in \mathbb{R}^6: \langle A\boldsymbol{\omega}, \mathbf{e} \rangle = c, \langle \mathbf{e}, \mathbf{e} \rangle = 1\}.$$

There always exists one integral of these equations on M_c – the energy integral. Thus, for complete integrability it is sufficient to have one more independent integral. We list the known integrable cases.

- 1) The Euler case (1750): $r_1 = r_2 = r_3 = 0$. The new integral $\langle A\boldsymbol{\omega}, A\boldsymbol{\omega} \rangle$ is the square of the magnitude of the angular momentum.
- 2) The Lagrange case (1788): $A_1 = A_2$ and $r_1 = r_2 = 0$. The new integral ω_3 is the projection of the angular velocity onto the axis of dynamical symmetry.
- 3) The Kovalevskaya case (1889): $A_1 = A_2 = 2A_3$ and $r_3 = 0$. Choose coordinate axes in the plane perpendicular to the axis of dynamical symmetry such that $r_2 = 0$. The integral found by Kovalevskaya is

$$(\omega_1^2 - \omega_2^2 - \nu e_1)^2 + (2\omega_1\omega_2 - \nu e_2)^2; \quad \nu = \frac{r_1}{A_3}.$$

- 4) The Goryachev–Chaplygin case (1900): $A_1 = A_2 = 4A_3$, $r_3 = 0$, and $c = \langle A\boldsymbol{\omega}, \mathbf{e} \rangle = 0$. In contrast to cases 1)–3), here we have an integrable Hamiltonian system only on one integral level M_0 .

Note that all these integrable cases form manifolds of the same codimension equal to three in the six-dimensional space of the parameters A_i, r_j .

The equations of motion in the first two cases were studied in detail from various viewpoints in the classical works of Euler, Poinso, Lagrange, Poisson, and Jacobi. The Kovalevskaya case is non-trivial in many respects. It was discovered by using the condition that the solutions of the Euler–Poisson equations be meromorphic in the complex time plane. The Goryachev–Chaplygin case is much simpler: it can be integrated by separation of variables [27]. For the proof we write the Hamiltonian function in the special canonical variables L, G, l, g (see § 3.2.3):

$$H = \frac{G^2 + 3L^2}{8A_3} + r \left(\frac{L}{G} \sin l \cos g + \cos l \sin g \right).$$

Consider the canonical transformation

$$L = p_1 + p_2, \quad G = p_1 - p_2, \quad q_1 = l + g, \quad q_2 = l - g.$$

In the new symplectic coordinates p, q we have

$$H = \frac{p_1^3 - p_2^3}{2A_3(p_1 - p_2)} + r \left(\frac{p_1}{p_1 - p_2} \sin q_1 + \frac{p_2}{p_1 - p_2} \sin q_2 \right).$$

Equating this expression to h and multiplying by $p_1 - p_2$ we see that the variables separate:

$$\frac{p_1^3}{2A_3} + rp_1 \sin q_1 - hp_1 = \frac{p_2^3}{2A_3} - rp_2 \sin q_2 - hp_2.$$

We set

$$\frac{p_1^3}{2A_3} + rp_1 \sin q_1 - Hp_1 = \Gamma, \quad \frac{p_2^3}{2A_3} - rp_2 \sin q_2 - Hp_2 = \Gamma. \quad (5.5)$$

The function Γ is a first integral of the equations of motion. In the traditional variables ω , e it has the form

$$\Gamma = 2A_3^2 f, \quad f = \omega_3(\omega_1^2 + \omega_2^2) - \nu\omega_1 e_3 \quad \left(\nu = \frac{r}{A_3} \right).$$

We write down the closed system of equations for the variation of p_1 , p_2 :

$$\dot{p}_1 = -\frac{\partial H}{\partial q_1} = \frac{rp_1}{p_1 - p_2} \cos q_1, \quad \dot{p}_2 = -\frac{\partial H}{\partial q_2} = \frac{rp_2}{p_1 - p_2} \cos q_2,$$

or, using (5.5),

$$\dot{p}_1 = \pm \frac{\pm\sqrt{\Phi(p_1)}}{p_1 - p_2}, \quad \dot{p}_2 = \pm \frac{\pm\sqrt{\Phi(p_2)}}{p_1 - p_2}, \quad (5.6)$$

where $\Phi(z) = r^2 z^2 - (\Gamma + Hz - z^3/2A_3)^2$ is a polynomial of degree six. Solutions of these equations can be expressed in terms of hyperelliptic functions of time. The variables p_1 and p_2 vary in the disjoint intervals $[a_1, b_1]$ and $[a_2, b_2]$, where a_i , b_i are the adjacent roots of the polynomial $\Phi(z)$ between which it takes positive values. If a_i (or b_i) is a multiple root, then the solution satisfies $p_i(t) \rightarrow a_i$ (respectively, $p_i(t) \rightarrow b_i$) as $t \rightarrow +\infty$ or $t \rightarrow -\infty$. Multiple roots correspond to the cases where the integrals H and Γ are dependent. Below we consider only the typical case of simple roots of the polynomial $\Phi(z)$.

We introduce the angle variables $\varphi_1, \varphi_2 \bmod 2\pi$ by the formulae

$$\varphi_i = \frac{\pi}{\tau_i} \int_{a_i}^{p_i} \frac{dz}{\pm\sqrt{\Phi(z)}}, \quad \tau_i = \int_{a_i}^{b_i} \frac{dz}{\sqrt{\Phi(z)}}. \quad (5.7)$$

In the new variables equations (5.6) take the form

$$\dot{\varphi}_i = \frac{\pi}{2\tau_i(p_1(\varphi_1) - p_2(\varphi_2))} \quad (i = 1, 2), \quad (5.8)$$

where the $p_i(z)$ are the real hyperelliptic functions with period 2π defined by relations (5.7). Since the trajectories of equations (5.8) on $\mathbb{T}^2 = \{\varphi_1, \varphi_2 \bmod 2\pi\}$ are straight lines, the ratio of the frequencies of the corresponding

conditionally periodic motions is equal to τ_1/τ_2 , which is the ratio of the real periods of the hyperelliptic integral

$$\int_{z_0}^z \frac{dz}{\sqrt{\Phi(z)}}.$$

This remarkable fact holds also for the equations of Kovalevskaya’s problem (see [27]).

b) Since equations of the form (5.8) are often encountered in the study of integrable problems of classical mechanics, we investigate them in more detail. To this end we consider differential equations on $\mathbb{T}^n = \{x_1, \dots, x_n \pmod{2\pi}\}$ of somewhat more general form:

$$\dot{x}_i = \frac{\omega_i}{f(x)}, \quad 1 \leq i \leq n, \tag{5.9}$$

where $\omega_i = \text{const} \neq 0$ and f is a smooth (or analytic) positive function defined on \mathbb{T}^n . Equations (5.9) admit the invariant measure

$$\text{meas}(D) = \int_D f(x) dx_1 \dots dx_n.$$

We denote by Λ the measure of the whole torus \mathbb{T}^n . We average the right-hand sides of the differential equation (5.9) using the operator

$$\frac{1}{\Lambda} \int_{\mathbb{T}^n} (\cdot) f(x) dx_1 \dots dx_n.$$

As a result we obtain the equations

$$\dot{\varphi}_i = \Omega_i = \frac{\omega_i}{\lambda} = \text{const} \quad (1 \leq i \leq n), \quad \lambda = \frac{\Lambda}{(2\pi)^n}. \tag{5.10}$$

Proposition 5.3. *Suppose that the partial differential equation*

$$\left\langle \frac{\partial R}{\partial x}, \omega \right\rangle = f - \lambda \tag{5.11}$$

has a smooth (analytic) solution $R(x_1, \dots, x_n): \mathbb{T}^n \rightarrow \mathbb{R}$. Then there exists a smooth (analytic) change of variables $x \rightarrow \varphi$ reducing system (5.9) to the form (5.10).

◁ Such a change of variables is given by the transformation

$$\varphi_i = x_i + \frac{\omega_i}{\lambda} R(x_1, \dots, x_n).$$

▷

Let

$$f(x) = \frac{A}{(2\pi)^n} + \sum_{k \neq 0} f_k e^{i\langle k, x \rangle}.$$

If $\omega_1, \dots, \omega_n$ are rationally incommensurable, then we can write down the formal equality

$$R(x) = \sum_{k \neq 0} \frac{f_k}{i\langle k, \omega \rangle} e^{i\langle k, x \rangle}. \quad (5.12)$$

This series defines a smooth function $R(x)$ if, for example, $f(x)$ is a trigonometric polynomial.

Proposition 5.4. *If f is a smooth function, then for almost every set of numbers $\omega_1, \dots, \omega_n$ equation (5.11) has a smooth solution.*

◁ Indeed, as k increases, the Fourier coefficients f_k are decreasing faster than any power, and for almost all ω we have the polynomial estimate

$$|\langle k, \omega \rangle| \geq \frac{c}{|k|^\gamma}, \quad c, \gamma = \text{const.}$$

Consequently, in this case the series (5.12) is converging absolutely and its sum is a smooth periodic function. ▷

If $f(x) = \sum_s f_s(x_s)$ (as in the case of system (5.8)), then equation (5.11) separates and therefore always has a solution, independently of the arithmetic properties of the frequencies $\omega_1, \dots, \omega_n$:

$$R = \sum_{s=1}^n \frac{F_s(x_s) - I_s x_s}{\omega_s}, \quad F_s(x) = \int_0^x f_s(t) dt, \quad I_s = \frac{1}{2\pi} F_s(2\pi).$$

In particular, equations (5.8) can always be reduced to the form (5.10), which must exist by Theorem 5.3.

c) The problem of the motion of a rigid body in an ideal fluid is much more rich in integrable cases. The equations of motion have the form of Kirchhoff's equations (see § 1.2.4):

$$\dot{\mathbf{k}} = \mathbf{k} \times \boldsymbol{\omega} + \mathbf{e} \times \mathbf{u}, \quad \dot{\mathbf{e}} = \mathbf{e} \times \boldsymbol{\omega}, \quad (5.13)$$

where $\boldsymbol{\omega} = H'_k$, $\mathbf{u} = H'_e$, and $H = \langle A\mathbf{k}, \mathbf{k} \rangle/2 + \langle B\mathbf{k}, \mathbf{e} \rangle + \langle C\mathbf{e}, \mathbf{e} \rangle/2$. Since the matrices A, C are symmetric, the matrix A can be reduced to the diagonal form: $A = \text{diag}(a_1, a_2, a_3)$. Thus, Kirchhoff's problem in the general case contains 18 parameters. Equations (5.13) always have three independent integrals: $F_1 = H$, $F_2 = \langle \mathbf{k}, \mathbf{e} \rangle$, and $F_3 = \langle \mathbf{e}, \mathbf{e} \rangle$. As in the case of a heavy top, the problem of integrating (5.13) amounts to finding a fourth independent integral. We describe two integrable cases; they were discovered by Clebsch

in 1871 and Steklov in 1893. In the Clebsch case it is assumed that $B = 0$, $C = \text{diag}(c_1, c_2, c_3)$, and

$$a_1^{-1}(c_2 - c_3) + a_2^{-1}(c_3 - c_1) + a_3^{-1}(c_1 - c_2) = 0.$$

The additional integral of Kirchhoff's equations has the form

$$k_1^2 + k_2^2 + k_3^2 - a_1 e_1^2 - a_2 e_2^2 - a_3 e_3^2.$$

In the Steklov case, $B = \text{diag}(b_1, b_2, b_3)$ and $C = \text{diag}(c_1, c_2, c_3)$, where $b_i = \mu(a_1 a_2 a_3) a_j^{-1} + \nu$, $c_1 = \mu^2 a_1 (a_2 - a_3)^2 + \nu'$, ... ($\mu, \nu, \nu' = \text{const}$).

The additional integral is

$$F_4 = \sum_j (k_j^2 - 2\mu(a_j + \nu)k_j e_j) + \mu^2((a_2 - a_3)^2 + \nu'')e_1^2 + \text{cyclic permutations}.$$

The parameters ν, ν', ν'' are inessential: they appear in connection with the presence of the classical integrals F_2 and F_3 .

In the case where the numbers a_1, a_2, a_3 are distinct, the integrals F_1, F_2, F_3 , and F_4 are almost everywhere independent. For $a_1 = a_2 \neq a_3$ the Steklov case becomes the already known Kirchhoff integrable case. Finally, if $a_1 = a_2 = a_3$, then we obtain the trivial degenerate case. However, as noted by Lyapunov, here we must take the function λF_4 ($\lambda = \text{const}$) as the Hamiltonian; then F_1 is obviously an additional integral. Therefore the integrable cases of Steklov and Lyapunov are "dual" to one another. A similar trick can also be applied to the Clebsch integrable case.

In 1902 Chaplygin found the following special integrable case:

$$2H = a(k_1^2 + k_2^2 + 2k_3^2) + b\langle \mathbf{k}, \mathbf{e} \rangle + a((d + c)e_1^2 + (d - c)e_2^2 + de_3^2).$$

The parameters b and d are inessential: they are not involved in the equations of motion. Under the assumption $F_2 = \langle \mathbf{k}, \mathbf{e} \rangle = 0$ there is an additional integral of degree four,

$$F_4 = (k_1^2 - k_2^2 + ce_3^2)^2 + 4k_1^2 k_2^2,$$

whose structure resembles Kovalevskaya's integral.

Quite recently Sokolov found one more integrable case [560]. In his case, $A = \text{diag}(1, 2, 2)$, $C = \text{diag}(0, -2\alpha^2, -2\alpha^2)$, and the matrix B is non-diagonal: $b_{13} = b_{31} = \alpha$, while its other elements are equal to zero. The additional integral is the polynomial of degree four

$$(k_3 - \alpha e_1)[(k_3 - \alpha e_1)(k^2 + 4\alpha(k_3 e_1 - k_1 e_3) + 4\alpha^2(e_1^2 + e_2^2)) + 6\alpha(k_1 - 2\alpha e_3)\langle \mathbf{k}, \mathbf{e} \rangle],$$

where $k^2 = \langle \mathbf{k}, \mathbf{k} \rangle$.

Since $a_1 = a_2 = a_3/2$ (as in the Chaplygin case), the Sokolov case can also be regarded as an analogue of the Kovalevskaya integrable case.

A critical survey of the theory of integrable problems in dynamics of a rigid body is contained in the book [138].

d) The motion of n point vortices on the plane (see § 1.3.4) is described by a Hamiltonian system with n degrees of freedom. Hamilton's equations have four first integrals: H , $P_x = \sum \Gamma_s x_s$, $P_y = \sum \Gamma_s y_s$, and $M = \sum \Gamma_s (x_s^2 + y_s^2)/2$, where Γ_s is the intensity of the s th vortex. It is easy to calculate their Poisson brackets: $\{P_x, P_y\} = -\sum \Gamma_s$, $\{P_x, M\} = -P_y$, $\{P_y, M\} = P_x$. Consequently, the problem of n vortices is completely integrable for $n \leq 3$. The case $n = 1$ is trivial; for $n = 2$ as independent commuting integrals one can take, for example, the functions H and M ; and for $n = 3$, the functions H , M , and $P_x^2 + P_y^2$. In the problem of four vortices the number of independent integrals is equal to the number of degrees of freedom, but not all of them commute. However, one can show that if the sum of the intensities of the vortices is equal to zero, then the solutions of the equations of motion with zero constants of the integrals P_x and P_y can be found by quadratures.

5.3 Some Methods of Integration of Hamiltonian Systems

A common feature of the various approaches to the problem of integration of Hamiltonian systems expounded in § 5.1 is the existence of a complete set of independent commuting integrals. In this section we indicate certain general methods of finding first integrals – “conservation laws”. The simplest and most effective method is separation of variables.

5.3.1 Method of Separation of Variables

We consider the system of canonical equations

$$\dot{p} = -H'_q, \quad \dot{q} = H'_p, \quad (p, q) \in \mathbb{R}^{2n}, \quad (5.14)$$

with Hamiltonian function $H(p, q)$. If we succeed in finding a canonical transformation $g: p, q \mapsto x, y$ such that in the new variables x, y the function $H(p, q) = K(x)$ is independent of y , then the canonical equations (5.14) can be easily integrated:

$$p = p(x, y), \quad q = q(x, y); \quad x = x_0, \quad y = y_0 + \omega(x_0)t, \quad \omega(x) = K'_x. \quad (5.15)$$

If $\det(\partial p/\partial x) \neq 0$, then the canonical transformation g can be defined locally by a generating function $S(x, q)$:

$$p = S'_q, \quad y = S'_x.$$

Thus, the problem of integrating the canonical equations reduces to finding a generating function S satisfying, in view of the equality $p = S'_q$, the nonlinear partial differential equation

$$H(S'_q, q) = K(x). \tag{5.16}$$

This equation with respect to the pair S, K is obtained from the *Hamilton–Jacobi equation* $V'_t + H(V'_q, q) = 0$ by the substitution $V(q, t) = -Kt + S(q)$. We emphasize that the function K in (5.16) is considered to be undetermined and one must use additional conditions for determining it uniquely (for example, see the application of equation (5.16) in perturbation theory in Ch. 6). It is customary to set $K(x_1, \dots, x_n) = x_1$; the trajectories of the system with this Hamiltonian are straight lines in \mathbb{R}^{2n} with coordinates x, y .

A solution $S(q_1, \dots, q_n, x_1, \dots, x_n)$, $i, j = 1, \dots, n$, of equation (5.16) with some function $K(x_1, \dots, x_n)$ satisfying the condition

$$\det \left(\frac{\partial^2 S}{\partial q_i \partial x_j} \right) \neq 0,$$

is called a *complete integral* of this equation.

Theorem 5.12. *If a complete integral $S(x, q)$ of equation (5.16) is found, then the canonical equations $\dot{p} = -H'_q$, $\dot{q} = H'_p$ can be integrated by quadratures. In this case the n functions $x_1(p, q), \dots, x_n(p, q)$ determined from the equations $p = \partial S(x, q)/\partial q$ form a complete set of independent integrals in involution:*

$$\text{rank} \frac{\partial(x_1, \dots, x_n)}{\partial(p_1, \dots, p_n, q_1, \dots, q_n)} = n.$$

The proof of this theorem of Jacobi follows from Proposition 1.9 in Ch. 1 and formulae (5.15). The method for integrating Hamilton’s equations based on Theorem 5.12 was proposed by Jacobi in 1837. Jacobi relied on the earlier work of Hamilton. The Hamilton–Jacobi method goes back to the studies of Pfaff and Cauchy in the theory of characteristics of partial differential equations.

Definition 5.2. If equation (5.16) possesses a complete integral of the form $S(x, q) = \sum_k S_k(q_k, x_1, \dots, x_n)$, then the variables q_1, \dots, q_n are said to be *separable*.

Proposition 5.5. *Suppose that in some symplectic coordinates $(p, q) = (p_1, \dots, p_n, q_1, \dots, q_n)$ the Hamiltonian function $H(p, q)$ has one of the following forms:*

- 1) $H = f_n(f_{n-1}(\dots f_2(f_1(p_1, q_1), p_2, q_2), \dots p_{n-1}, q_{n-1}), p_n, q_n)$,
- 1') $H = \sum f_s(p_s, q_s) / \sum g_s(p_s, q_s)$.

Then the functions

$$\begin{aligned} 2) \quad & F_1 = f_1(p_1, q_1), \quad F_2 = f_2(f_1(p_1, q_1), p_2, q_2), \dots, \quad F_n = H, \\ 2') \quad & F_0 = H, \quad F_s = f_s(p_s, q_s) - Hg(p_s, q_s), \quad 1 \leq s \leq n, \end{aligned}$$

respectively, form a complete set of integrals in involution of the Hamiltonian system with Hamiltonian H .

Consider, for example, case 1'. Setting $K = x_0$ we write down equation (5.16):

$$\sum_k x_0 g_k \left(\frac{\partial S}{\partial q_k}, q_k \right) - f_k \left(\frac{\partial S}{\partial q_k}, q_k \right) = 0.$$

A complete integral of it can be found as the sum

$$\sum_k S_k(q_k, x_0, x_k),$$

where S_k , as a function of q_k , satisfies the ordinary differential equation

$$x_0 g_k \left(\frac{dS_k}{dq_k}, q_k \right) - f_k \left(\frac{dS_k}{dq_k}, q_k \right) = x_k, \quad \sum_{k \geq 1} x_k = 0.$$

The variables x_0, x_1, \dots, x_n are first integrals in involution (Theorem 5.12). In the general case any n of them are independent.

Proposition 5.5 describes the simplest and most common types of separation of variables. In fact, we already used separation of symplectic coordinates of type 1' in solving the Goryachev–Chaplygin problem in § 5.2.3. We remark that cases 1 and 1' of Proposition 5.5 can occur in combination with each other; besides, more complicated types of separation of variables are possible.

Example 5.6 (Stäckel, 1895). Let Φ be the determinant of the matrix $(\varphi_{ij}(q_j))$ ($1 \leq i, j \leq n$), and Φ_{ij} the cofactor of an element φ_{ij} . Suppose that in the symplectic coordinates $p_1, \dots, p_n, q_1, \dots, q_n$ the Hamiltonian function has the form

$$H(p, q) = \sum_{s=1}^n \frac{\Phi_{1s}(q) f_s(p_s, q_s)}{\Phi(p, q)}; \quad (5.17)$$

then Hamilton's equations are integrable. Setting $K(x) = x_1$ we write down equation (5.16):

$$\sum_m \Phi_{1m} \left[\sum_k x_k \varphi_{km}(q_m) - f_m \left(\frac{\partial S}{\partial q_m}, q_m \right) \right] = 0.$$

A complete integral of it can be found as the sum

$$S(x, q) = \sum_m S_m(q_m, x_1, \dots, x_n),$$

where S_k , as a function of q_k , satisfies the equation

$$f_m\left(\frac{dS_m}{dq_m}, q_m\right) = \sum_k x_k \varphi_{km}(q_m).$$

One can show that the n functions

$$F_k(p, q) = \sum_s \frac{\Phi_{ks} f_s}{\Phi}$$

form a complete involutive set of integrals of the Hamiltonian system with Hamiltonian (5.17). △

Of course, there is no general rule for finding separable variables. “Therefore one has to adopt the opposite approach and, after finding a remarkable substitution, to seek the problems for which this substitution can be successfully used.”⁴ Here we indicate one such “remarkable substitution” related to *elliptic coordinates* in \mathbb{R}^n .

Let $0 < a_1 < a_2 < \dots < a_n$ be distinct positive numbers. For every $x = (x_1, \dots, x_n) \in \mathbb{R}^n$ the equation $f(\lambda) = 1$, where

$$f(\lambda) = \sum_s \frac{x_s^2}{a_s - \lambda}, \tag{5.18}$$

defines n real numbers $\lambda_1, \dots, \lambda_n$ that separate a_1, \dots, a_n (see Fig. 5.2): $\lambda_1 < a_1 < \lambda_2 < \dots < \lambda_n < a_n$. The numbers $\lambda_1, \dots, \lambda_n$ serve as curvilinear coordinates in \mathbb{R}^n and are called the *Jacobi elliptic coordinates*.

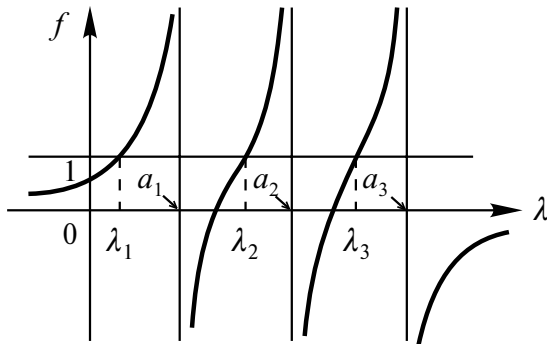

Fig. 5.2.

⁴ C. Jacobi, *Vorlesungen über Dynamik*.

One can show that

$$x_i^2 = \frac{\prod_{s=1}^n (a_i - \lambda_s)}{\prod_{\substack{s=1 \\ s \neq i}}^n (a_i - a_s)}. \quad (5.19)$$

Using this formula one can easily derive the relation $4 \sum_s \dot{x}_s^2 = \sum_s M_s \dot{\lambda}_s^2$, where

$$M_s = \frac{\prod_{i \neq s} (\lambda_i - \lambda_s)}{\prod_i (a_i - \lambda_s)}. \quad (5.20)$$

Note the curious duality of formulae (5.19) and (5.20).

We now pass to the symplectic coordinates $\lambda_s, \mu_s = M_s \dot{\lambda}_s / 4$. Then the energy of free motion of a point in \mathbb{R}^n takes the form

$$H = \frac{1}{2} \sum \dot{x}_s^2 = 2 \sum \frac{\mu_s^2}{M_s(\lambda)}. \quad (5.21)$$

Here it is not immediately clear how the symplectic variables λ, μ can be separated. We use the following formula of Jacobi: the sum

$$\sum_{s=1}^n \frac{\lambda_s^m}{\prod_{i \neq s} (\lambda_s - \lambda_i)}$$

is equal to zero for $m < n - 1$, and to 1 for $m = n - 1$. Using this formula we can represent equality (5.21) in the form

$$\sum_s \frac{\sum_{m=0}^{n-1} F_m \lambda_s^m}{\prod_{i \neq s} (\lambda_s - \lambda_i)} = 2 \sum_s \frac{\mu_s^2 \prod_j (\lambda_s - a_j)}{\prod_{i \neq s} (\lambda_s - \lambda_i)}.$$

Here $F_{n-1} = H$, and F_0, F_1, \dots, F_{n-2} are for the moment arbitrary. Now the variables λ, μ can be separated: we can set

$$\sum_{m=0}^{n-1} F_m \lambda_s^m = 2\mu_s^2 \prod_{j=1}^n (\lambda_s - a_j).$$

From this system of equations we find F_0, F_1, \dots, F_{n-2} as functions of λ, μ ; they provide a complete set of independent integrals in involution.

At first glance this result may seem trivial: the complete integrability of the problem of free motion of a point in \mathbb{R}^n was obvious from the outset. However, the formulae of separation of variables obtained above imply quite a non-obvious result of Jacobi on the integrability of the problem of the motion of a point on the surface of a multidimensional ellipsoid in the absence of external forces (according to Maupertuis's principle the trajectories of the moving

point coincide with the geodesics). Indeed, let us fix a value of the variable λ_1 , say, $\lambda_1 = 0$. Then $\lambda_2, \dots, \lambda_n$ are curvilinear orthogonal coordinates on the surface of the $(n - 1)$ -dimensional ellipsoid $\sum x_s^2/a_s = 1$. The Hamiltonian of the problem of the geodesics is given by formula (5.21) in which we must set $\lambda_1 = 0, \mu_1 = 0$. The separation of the variables $\lambda_2, \mu_2, \dots, \lambda_n, \mu_n$ is realized by the scheme indicated above. Note that in the case of two-dimensional ellipsoid, the Hamiltonian has form 1') in Proposition 5.5. If we fix the value of one of the variables $\lambda_2, \dots, \lambda_n$, then by the same method we obtain the complete integrability of the problem of the geodesics on multidimensional hyperboloids of all possible types. We indicate the geometric meaning of the integrals: these are the numbers of the quadrics (there are $n - 1$ of them in \mathbb{R}^n) to which the tangent to the geodesic is tangent (the quadrics are the same for all points of the same geodesic). The results of the qualitative analysis of the behaviour of the geodesics on the surface of a two-dimensional ellipsoid based on Jacobi's formulae can be found in [10]. Jacobi showed that the problem of free motion on an ellipsoid remains integrable if the point is acted upon by an elastic force whose action line passes through the centre of the ellipsoid.

As another application of elliptic coordinates we consider the problem of the planar motion of a material point in the field of attraction of *two fixed centres*. This problem was integrated by Euler in 1760. Let x_1, x_2 be Cartesian coordinates in the plane of motion, and let $(0, c), (0, -c)$ be the coordinates of the attracting centres; $c > 0$. We pass to the elliptic coordinates in the plane $\mathbb{R}^2 = \{x_1, x_2\}$ assuming that $a_2 - a_1 = 2c$. This means, in particular, that for a fixed value of λ the equation

$$\frac{x_1^2}{a_1 - \lambda} + \frac{x_2^2}{a_2 - \lambda} = 1$$

defines a conic section whose foci coincide with the fixed centres. In the symplectic coordinates λ, μ the Hamiltonian function of this problem is

$$H = 2 \frac{(a_1 - \lambda_1)(a_2 - \lambda_1)}{\lambda_2 - \lambda_1} \mu_1^2 + 2 \frac{(a_1 - \lambda_2)(a_2 - \lambda_2)}{\lambda_1 - \lambda_2} \mu_2^2 + U(\lambda_1 \lambda_2),$$

where U is the potential energy of interaction. Let r_1, r_2 be the distances from the moving point to the attracting centres. Using formula (5.19) for $n = 2$ one can easily obtain that

$$\begin{aligned} r_1^2 &= (x_2 + c)^2 + x_1^2 = (\sqrt{a_2 - \lambda_1} + \sqrt{a_2 - \lambda_2})^2, \\ r_2^2 &= (x_2 - c)^2 + x_1^2 = (\sqrt{a_2 - \lambda_1} - \sqrt{a_2 - \lambda_2})^2. \end{aligned}$$

Consequently,

$$U = \frac{\gamma_1}{r_1} + \frac{\gamma_2}{r_2} = \frac{\gamma_1 r_1 + \gamma_2 r_2}{r_1 r_2} = \frac{(\gamma_1 + \gamma_2)\sqrt{a_2 - \lambda_1} - (\gamma_1 - \gamma_2)\sqrt{a_2 - \lambda_2}}{\lambda_1 - \lambda_2}.$$

As a result the variables λ_1, μ_1 and λ_2, μ_2 separate, and by Proposition 5.5 the problem of two fixed centres is integrable. Lagrange showed that the integrability is preserved if the point is acted upon by an additional elastic force

directed towards the midpoint of the segment connecting the attracting centres. The qualitative analysis of the problem of two centres can be found in the book of Charlier [20].

It is interesting that the classical results of Euler and Lagrange remain valid also in the case of a space of constant curvature. In [351] the generalized problem of two fixed centres was solved where these centres create potentials of Newtonian type (2.21) (see Ch. 2). The separation of variables takes place in the so-called spheroconical coordinates (degenerate Jacobi elliptic coordinates; see [442]). Moreover, this problem remains integrable if the generalized potential of an elastic spring is added (see § 2.7) whose centre is at the midpoint of the arc connecting the attracting centres.

In conclusion we mention two important problems, which can be solved by the method of separation of variables.

1) Kepler's problem in a homogeneous force field: this means the motion of a point under the action of a gravitational attraction of a fixed centre and an additional force of constant magnitude and direction. The separation of variables is achieved by introducing the "parabolic" coordinates which are obtained from the elliptic coordinates by passing to the limit as one of the foci moves away to infinity. This problem was solved by Lagrange in 1766.

2) The problem of the motion of a point on the sphere $\langle x, x \rangle = 1$, $x \in \mathbb{R}^n$, in a force field with quadratic potential $U(x) = \langle Ax, x \rangle$. The separation of variables is carried out in elliptic coordinates. For $n = 3$ this problem was first considered by Neumann in 1859. The case of arbitrary n is discussed in detail in [38].

5.3.2 Method of L - A Pairs

This method is based on representing the differential equation $\dot{x} = f(x)$, $x = (x_1, \dots, x_n)$, in the form of the following matrix equation with respect to a matrix L :

$$\dot{L} = [A, L], \quad (5.22)$$

where the elements of the square matrices A and L (possibly, complex numbers) are functions of x_1, \dots, x_n and by definition $[A, L] = AL - LA$. Equation (5.22) arises naturally in many problems of mechanics and physics.

Example 5.7. The Euler equation $\dot{\mathbf{M}} = \mathbf{M} \times \boldsymbol{\omega}$ can be represented in the form (5.22) if we set

$$L = \begin{pmatrix} 0 & M_1 - M_2 & \\ -M_1 & 0 & M_3 \\ & M_2 - M_3 & 0 \end{pmatrix}, \quad A = \begin{pmatrix} 0 & \omega_1 - \omega_2 & \\ -\omega_1 & 0 & \omega_3 \\ & \omega_2 - \omega_3 & 0 \end{pmatrix},$$

where $(M_1, M_2, M_3) = \mathbf{M}$ and $(\omega_1, \omega_2, \omega_3) = \boldsymbol{\omega}$. The eigenvalues of the matrix L are the numbers $0, \pm i\langle \mathbf{M}, \mathbf{M} \rangle$; they are constant on the trajectories of the Euler equation. \triangle

It turns out that this remark is not accidental.

Proposition 5.6. *The eigenvalues of the operator L are first integrals of equation (5.22).*

◁ We have $L(t + s) = e^{sA}L(t)e^{-sA} + o(s)$ as $s \rightarrow 0$. Hence,

$$\det(L(t + s) - \lambda E) = \det(L(t) - \lambda E) + o(s).$$

Consequently, $\det(L(t) - \lambda E)$ is independent of t . ▷

In practice it is of course more convenient to deal not with the eigenvalues λ_j themselves but with the symmetric polynomials in λ_j equal to the coefficients of the characteristic equation $\det(L - \lambda E) = 0$. The question whether the first integrals found by this method are independent and form a complete set is the subject of a separate investigation in each concrete case.

Example 5.8 (Toda's chain). Consider n particles on a straight line with coordinates x_1, \dots, x_n satisfying the equations

$$\ddot{x}_i = -U'_{x_i}, \quad U = \sum_{k=1}^n \exp(x_k - x_{k+1}), \quad x_{n+1} \equiv x_1. \quad (5.23)$$

As shown by Hénon, Flaschka, and Manakov (1974), this system can be represented by an L - A pair. For example, one can set

$$L = \begin{pmatrix} b_1 & a_1 & \dots & 0 \\ a_1 & b_2 & \dots & 0 \\ \dots & \dots & \dots & \dots \\ 0 & \dots & a_{n-1} & b_n \end{pmatrix}, \quad A = \begin{pmatrix} 0 & a_1 & \dots & 0 \\ -a_1 & 0 & \dots & 0 \\ \dots & \dots & \dots & \dots \\ 0 & \dots & -a_{n-1} & 0 \end{pmatrix},$$

where $2a_k = \exp\{(x_k - x_{k+1})/2\}$ and $2b_k = -\dot{x}_k$. Proposition 5.6 implies that the eigenvalues of L are integrals of equations (5.23); one can show that they are independent and commute. Moser [440] used the same method to establish the integrability of a system of points of equal masses on a straight line with the potential of binary interaction

$$\sum_{k < l} u(x_k - x_l),$$

where $u(z)$ is one of the functions z^{-2} , $\sin^{-2}z$, $\sinh^{-2}z$. Pidkuiko and Stepin [500] generalized this result by establishing the complete integrability of the equations of motion of points with potential $\wp(z)$. The potentials considered by Moser are degenerate cases of the Weierstrass \wp -function. Motion of several points on a straight line can be regarded as the motion of a single point in a Weyl chamber of the Lie algebra A_k under the action of a potential increasing near the walls of this chamber. Analogous problems for other simple Lie algebras (with potentials of the same kind) are also integrable (Perelomov, Ol'shanetskij). The problem of free motion of a rigid body in \mathbb{R}^n also proved to be integrable (Manakov). △

An L - A -representation was found for almost every integrable problem of classical mechanics. Furthermore, various algebra-geometric constructions were found clarifying the reasons for the existence of “hidden” conservation laws. The existence of an L - A -representation helps not only to find first integrals, but also to perform an explicit integration of the equations of motion. Discussions of various aspects of the modern theory of integration of Hamiltonian systems can be found in [38, 57, 216].

5.4 Integrable Non-Holonomic Systems

5.4.1 Differential Equations with Invariant Measure

We consider the differential equation

$$\dot{x} = f(x), \quad x \in \mathbb{R}^n, \quad (5.24)$$

and let $\{g^t\}$ be its phase flow. Suppose that equation (5.24) has an integral invariant with some smooth density $M(x)$, which means that

$$\int_{g^t(D)} M(x) dx = \int_D M(x) dx \quad (5.25)$$

for any measurable domain $D \subset \mathbb{R}^n$ and for all t . Recall the well-known assertion of Liouville on the existence of an integral invariant.

Proposition 5.7. *A smooth function $M: \mathbb{R}^n \rightarrow \mathbb{R}$ is the density of the invariant*

$$\int M(x) dx$$

if and only if

$$\operatorname{div}(Mf) = 0. \quad (5.26)$$

If $M(x) > 0$ for all x , then formula (5.25) defines a *measure* in \mathbb{R}^n that is *invariant* under the action of g^t . The existence of an invariant measure simplifies integration of the differential equation; for example, for $n = 2$ it is then integrable by quadratures. Indeed, (5.26) implies the local solubility of the system of equations with respect to $F(x_1, x_2)$

$$F'_{x_1} = Mf_1, \quad F'_{x_2} = -Mf_2.$$

From this system the function $F(x_1, x_2)$ can be found by simple quadratures. It remains to note that F is a first integral of system (5.24). According to Euler the function M is also called an *integrating factor*.

Theorem 5.13. *Suppose that the system of equations (5.24) with an invariant measure (5.25) has $n - 2$ first integrals F_1, \dots, F_{n-2} . Suppose that the differentials of the functions F_1, \dots, F_{n-2} are linearly independent on an invariant set $M_c = \{x \in \mathbb{R}^n: F_s(x) = c_s, 1 \leq s \leq n - 2\}$. Then*

1) *the solutions of equation (5.24) lying on M_c can be found by quadratures.*

If L_c is a compact connected component of the level set M_c and $f(x) \neq 0$ on L_c , then

- 2) *L_c is a smooth manifold diffeomorphic to the two-dimensional torus;*
- 3) *on L_c there exist angle coordinates $x, y \bmod 2\pi$ such that in these variables equation (5.24) on L_c takes the form*

$$\dot{x} = \frac{\lambda}{\Phi(x, y)}, \quad \dot{y} = \frac{\mu}{\Phi(x, y)}, \tag{5.27}$$

where $\lambda, \mu = \text{const}$ and Φ is a smooth positive function 2π -periodic in x and y .

We indicate the main steps of the proof. Since the vector field f is tangent to M_c , differential equation (5.24) can be restricted to M_c . This equation on M_c will have an invariant measure (see § 1.3.6, also for the explicit formula for the density of an invariant measure). The integrability by quadratures on M_c now follows from Euler’s remark. Conclusion 1 of Theorem 5.13 (first noted by Jacobi) is thus proved. Conclusion 2 is the well-known topological fact that every connected compact orientable two-dimensional manifold admitting a tangent field without singular points is diffeomorphic to the two-dimensional torus. Conclusion 3 is in fact *Kolmogorov’s theorem* (1953) on reduction of differential equations on the torus with a smooth invariant measure [317].

Example 5.9. Consider Chaplygin’s problem of a balanced but dynamically asymmetric ball rolling on a rough horizontal plane (§ 3.1.2, Example 3.5). The motion of the ball is described by the following system of equations in $\mathbb{R}^6 = \mathbb{R}^3\{\omega\} \times \mathbb{R}^3\{\gamma\}$:

$$\dot{\mathbf{k}} + \omega \times \mathbf{k} = 0, \quad \dot{\gamma} + \omega \times \gamma = 0; \quad \mathbf{k} = I\omega + ma^2\gamma \times (\omega \times \gamma). \tag{5.28}$$

Here I is the inertia tensor of the ball, m its mass, a its radius. These equations have an invariant measure with the density

$$M = \frac{1}{\sqrt{(ma^2)^{-1} - \langle \gamma, (I + ma^2E)^{-1}\gamma \rangle}}, \quad E = (\delta_{ij}).$$

Taking into account the existence of the four independent integrals $F_1 = \langle \mathbf{k}, \mathbf{k} \rangle$, $F_2 = \langle \mathbf{k}, \gamma \rangle$, $F_3 = \langle \gamma, \gamma \rangle = 1$, $F_4 = \langle \mathbf{k}, \omega \rangle$ we see that equations (5.28) can be integrated by quadratures. Note that the system of equations (5.28)

has no equilibrium positions on regular level sets M_c . Indeed, if $\dot{\gamma} = 0$, then the vectors ω and γ are dependent. This in turn implies that the differentials dF_2 and dF_4 are linearly dependent.

Equations (5.28) can be integrated most easily in the case where the constant of the “area” integral F_2 is equal to zero. In the elliptic coordinates u, v on the Poisson sphere $\langle \gamma, \gamma \rangle = 1$ the equations of motion on a level M_c can be reduced to the form

$$\dot{u} = \frac{\sqrt{P_5(u)}}{u(u^{-1} - v^{-1})\Phi(u, v)}, \quad \dot{v} = \frac{\sqrt{P_5(v)}}{v(u^{-1} - v^{-1})\Phi(u, v)},$$

where $\Phi = \sqrt{(\alpha - u)(\alpha - v)}$. The coefficients of the polynomial P_5 of degree 5 and the constant α depend on the parameters of the problem and the constants of the first integrals (details can be found in [19]). The variables u, v vary in the two different closed intervals where the polynomial P_5 takes non-negative values. The uniformizing change of variables (5.7) (see § 5.2.3) in which $\Phi(z)$ must be replaced by the function $P_5(z)/z^2$ introduces angle coordinates on M_c , in which the equation of motion takes the form (5.27). The ratio λ/μ (the rotation number of the tangent vector field) is equal to the ratio of the real periods of the abelian integral

$$\int \frac{z \, dz}{\sqrt{P_5(z)}}.$$

In contrast to equations (5.8), in Chaplygin’s problem the variables x, y are not separable. △

According to Propositions 5.3 and 5.4, for almost every set of numbers (λ, μ) the differential equation (5.27) can be reduced in some angle coordinates x', y' to the equation

$$\dot{x}' = \lambda', \quad \dot{y}' = \mu' \quad (\lambda', \mu' = \text{const}). \tag{5.29}$$

Proposition 5.8. *Suppose that λ and μ are rationally incommensurable, and let $\Phi(x, y) = \sum \Phi_{mn} \exp \{i(mx + ny)\}$. If there exists a smooth change of angle variables $x, y \mapsto x', y'$ reducing system (5.27) to system (5.29), then*

$$\sum_{|m|+|n| \neq 0} \left| \frac{\Phi_{mn}}{m\lambda + n\mu} \right|^2 < \infty. \tag{5.30}$$

In the general case (where the Fourier expansion of the function Φ contains all harmonics) the points $(\lambda, \mu) \in \mathbb{R}^2$ for which the series (5.30) diverges are everywhere dense in \mathbb{R}^2 . A discussion of the questions of reducibility of equations (5.27) can be found in Kolmogorov’s paper [317].

In conclusion we indicate some qualitative properties of solutions of system (5.27) that are independent of the arithmetic nature of the numbers λ, μ .

We denote the initial values of x, y by x_0, y_0 , respectively. Theorem 5.4 (under the assumption of incommensurability of λ and μ) implies that

$$x = x_0 + \frac{\lambda}{\langle \Phi \rangle} t + X(t, x_0, y_0), \quad y = y_0 + \frac{\mu}{\langle \Phi \rangle} t + Y(t, x_0, y_0),$$

where

$$\langle \Phi \rangle = \frac{1}{(2\pi)^2} \int_0^{2\pi} \int_0^{2\pi} \Phi \, dx \, dy, \quad \lim_{t \rightarrow \infty} \frac{X}{t} = \lim_{t \rightarrow \infty} \frac{Y}{t} = 0.$$

We define the distance d between points of $\mathbb{T}^2 = \{x, y \bmod 2\pi\}$ by the metric $dx^2 + dy^2$.

Theorem 5.14 ([27]). *If λ and μ are incommensurable, then*

a) *for any $\varepsilon > 0$ and $T > 0$ there exists $\tau > T$ such that*

$$|X(\tau, x_0, y_0)| < \varepsilon, \quad |Y(\tau, x_0, y_0)| < \varepsilon, \quad d\{(x(\tau), y(\tau)), (x_0, y_0)\} < \varepsilon$$

for all $(x_0, y_0) \in \mathbb{T}^2$;

b) *if $\Phi(x_0, y_0) \neq \langle \Phi \rangle$, then the function $X^2(t, x_0, y_0) + Y^2(t, x_0, y_0)$ has infinitely many zeros as $t \rightarrow \infty$;*

c) *there exist points $(x_0, y_0) \in \mathbb{T}^2$ with $\Phi(x_0, y_0) \neq \langle \Phi \rangle$ such that the inequalities $X(t, x_0, y_0) \geq 0$ (or ≤ 0) and $Y(t, x_0, y_0) \geq 0$ (respectively, ≤ 0) hold simultaneously for all t .*

Conclusion a) implies, in particular, that (for incommensurable λ and μ) the ergodic phase flow of system (5.27) is not mixing [306, 316]. Note that if the rotation number λ/μ is abnormally rapidly approximated by rational numbers, then system (5.27) can be weakly mixing (or, which is the same, can have continuous spectrum); see [317, 67].

In [79] the possibility of mixing was predicted for system (5.27) with singular points (at these points the function Φ has singularities). Conditions for such special flows to be mixing were found in [554].

5.4.2 Some Solved Problems of Non-Holonomic Mechanics

a) We show that the problem of a balanced dynamically asymmetric ball rolling on a rough plane remains integrable if the particles of the ball are attracted by this plane proportionally to the distance [332]. Since the centre of mass of the ball coincides with its geometric centre, the potential can be calculated by the formula

$$U(\gamma) = \frac{\varepsilon}{2} \int \langle \mathbf{r}, \boldsymbol{\gamma} \rangle^2 \, dm = \frac{\varepsilon}{2} \langle J\boldsymbol{\gamma}, \boldsymbol{\gamma} \rangle, \tag{5.31}$$

where γ is the unit vertical vector, r the position vector of a particle of the ball, and J the inertia tensor of the ball relative to its centre. The attraction forces create the moment of force

$$\int \mathbf{r} \times (\varepsilon \langle \mathbf{r}, \gamma \rangle \gamma) dm = \varepsilon \int \langle \mathbf{r}, \gamma \rangle \langle \mathbf{r}, \gamma \rangle dm = U'_\gamma \times \gamma = \varepsilon (J\gamma \times \gamma).$$

To obtain the moment of forces relative to the contact point we must add the moment of the resultant force

$$\varepsilon \int \langle \mathbf{r}, \gamma \rangle \gamma dm = \varepsilon \left\langle \int \mathbf{r} dm, \gamma \right\rangle \gamma,$$

which is equal to zero because the centre of mass coincides with the geometric centre of the ball. Thus, the equation of rolling of the ball can be represented in the following form (cf. equations (3.5) in § 3.1.2):

$$\dot{\mathbf{k}} + \boldsymbol{\omega} \times \mathbf{k} = -\varepsilon (J\gamma \times \gamma), \quad \dot{\gamma} + \boldsymbol{\omega} \times \gamma = 0. \tag{5.32}$$

These equations have four independent integrals:

$$\begin{aligned} F_1 &= \langle \mathbf{k}, \boldsymbol{\omega} \rangle + \varepsilon \langle J\gamma, \gamma \rangle, & F_2 &= \langle \mathbf{k}, \gamma \rangle, \\ F_3 &= \langle \gamma, \gamma \rangle = 1, & F_4 &= \langle \mathbf{k}, \mathbf{k} \rangle - \langle A\gamma, \gamma \rangle, \end{aligned}$$

where

$$A = \text{diag} (A_1, A_2, A_3), \quad A_1 = \varepsilon (J_2 + ma^2)(J_3 + ma^2), \quad \dots$$

Since equations (5.32) have an invariant measure with the density indicated after equations (5.28), they are integrable by Theorem 5.13.

Note that the problem of the rotation of a rigid body around a fixed point in an axially symmetric force field with the potential (5.31) is also integrable. Apart from the three classical integrals F_1, F_2, F_3 , this problem has the integral F_4 in which we must put $a = 0$. The integral F_4 was first found by Tissèrand in 1872 in connection with the study of rotation of celestial bodies. The fact is that the potential of a rigid body in a central Newtonian force field coincides with the potential (5.31) to within $O(\rho^4/R^4)$, where ρ is the characteristic size of the rigid body and R is the distance from the body to the attracting centre. As first noted by Steklov (1902), the Euler–Poisson equations with the potential (5.31) have the same form as Kirchhoff’s equations of the problem of the motion of a rigid body in an ideal fluid in the Clebsch case (1871). Moreover, the integral F_4 corresponds exactly to the integral found by Clebsch.

b) As another example consider the problem of a homogeneous disc rolling without slipping on a rough horizontal plane under the action of the gravitational force. This problem was solved by Appell and Korteweg in 1899. Let $Oxyz$ be a moving coordinate system, where O is the centre of the disc, the

axis Oz is orthogonal to the plane of the disc, the axis Ox is always horizontal, and the axis Oy contains the contact point. Let u, v, w and p, q, r be the projections onto these axes of the velocity of the centre of mass and the angular velocity of rotation of the disc. If a is the radius of the rolling disc, then

$$u = -ar, \quad v = 0, \quad w = ap.$$

Let m be the mass of the disc and let A and C be the moments of inertia of the disc relative to the axes Ox and Oz . The following equations of motion hold (see [5]):

$$(C + ma^2)\dot{r} = ma^2pq, \quad A\dot{q} = (Cr - Aq \cot \vartheta)p,$$

where ϑ is the angle between the axis Oz and the vertical. Since $p = \dot{\vartheta}$, this system yields the following linear differential equations, which determine the integrals of the equations of motion $q = q(\vartheta)$ and $r = r(\vartheta)$:

$$(c + ma^2)\frac{dr}{d\vartheta} = ma^2q, \quad A\frac{dq}{d\vartheta} = Cr - Aq \cot \vartheta. \quad (5.33)$$

As noted by Appell and Korteweg, the functions $q(\vartheta)$ and $r(\vartheta)$ can be expressed in terms of the Gaussian hypergeometric series. The angle ϑ , as a function of t , can be found by a simple quadrature from the energy integral

$$m(u^2 + v^2 + w^2) + A(p^2 + q^2) + Cr^2 = -2mga \sin \vartheta + h, \quad (5.34)$$

where g is the acceleration of gravity and h is an arbitrary constant. Using these formulae one can show that $0 < \vartheta(t) < \pi$ for almost all initial states (with the exception of the points lying on some hypersurface in the phase space). This result explains the amazing ability of the disc to roll on the plane without falling. Indeed, let $q_1(\vartheta), r_1(\vartheta)$ be a solution of the linear system (5.33) that is bounded as $\vartheta \rightarrow 0$ (or $\vartheta \rightarrow \pi$). If $q_2(\vartheta), r_2(\vartheta)$ is another solution, then by Liouville's formula we have

$$q_1(\vartheta)r_2(\vartheta) - q_2(\vartheta)r_1(\vartheta) = c \exp \left\{ \int_{\pi/2}^{\vartheta} \cot x \, dx \right\} = \frac{c}{\sin \vartheta}, \quad c = \text{const.}$$

Since the right-hand side of this equality tends to $+\infty$ as $\vartheta \rightarrow 0$ (or π), any solution that is bounded as $\vartheta \rightarrow 0$ (or $\vartheta \rightarrow \pi$) is linearly dependent with the solution $q = q_1(\vartheta), r = r_1(\vartheta)$. Thus, almost surely $q^2 + r^2 \rightarrow \infty$ at the ends of the interval $(0, \pi)$. Since the right-hand side of the energy integral (5.34) is bounded, it is obvious that the inequality $\varepsilon < \vartheta(t) < \pi - \varepsilon$ (where $\varepsilon > 0$) holds for all values of t .

The Appell–Korteweg method can be used to solve the related problem of the motion of a circular homogeneous disc with a sharp edge on smooth horizontal ice. The non-holonomic constraint is that the velocity of the contact

point of the disc is parallel to its horizontal diameter. In contrast to the Appell–Korteweg problem, here the first integrals can be expressed in terms of elementary functions and have a simple mechanical meaning: the projections of the angular momentum of the disc relative to its centre onto the vertical and onto the axis Oz are conserved. For almost all initial conditions the disc never falls onto the ice and the trajectory of its contact point is bounded. More precisely, the contact point describes some closed curve, which in turn rotates as a rigid body with constant angular velocity around some point (see the details in [353]).

The problem of a heavy circular disc sliding on a horizontal plane was considered in [59]. The centre of mass of the disc is assumed to coincide with its geometric centre; in the general case its principal central moments of inertia are distinct. It was shown that for almost all initial data the disc never falls onto the plane. The proof is based on regularization of the equations of motion, analysis of the invariant manifolds corresponding to falling, and application of the Schwarzschild–Littlewood theorem (Proposition 2.7 in Ch. 2). In the problem of a disc rolling on an absolutely rough plane this method is applicable only in the case of dynamical symmetry: the equations of rolling of an asymmetric disc have no invariant measure.

The more general problem of a dynamically symmetric disc rolling without slipping on an inclined plane was considered in [345]. This problem is non-integrable, but the equations of motion admit an invariant measure. It was shown that almost surely the disc rolls without falling.

c) Following Suslov we also consider the problem of the rotation of a rigid body around a fixed point with the non-integrable constraint $\langle \mathbf{a}, \boldsymbol{\omega} \rangle = 0$, where \mathbf{a} is a constant vector. Suppose that the body rotates in an axially symmetric force field with potential $U(\gamma)$. Applying the method of Lagrange multipliers (see § 1.2.5) we write down the equations of motion:

$$A\dot{\boldsymbol{\omega}} + \boldsymbol{\omega} \times A\boldsymbol{\omega} = \boldsymbol{\gamma} \times U'_\gamma + \lambda \mathbf{a}, \quad \dot{\gamma} + \boldsymbol{\omega} \times \boldsymbol{\gamma} = 0. \quad (5.35)$$

Using the constraint equation $\langle \mathbf{a}, \boldsymbol{\omega} \rangle = 0$ we can find the Lagrange multiplier as a function of $\boldsymbol{\omega}$ and γ :

$$\lambda = - \frac{\langle \mathbf{a}, A^{-1}(A\boldsymbol{\omega} \times \boldsymbol{\omega}) + A^{-1}(\boldsymbol{\gamma} \times U'_\gamma) \rangle}{\langle \mathbf{a}, A^{-1}\mathbf{a} \rangle}.$$

Equations (5.35) always have the three independent first integrals

$$F_1 = \frac{\langle A\boldsymbol{\omega}, \boldsymbol{\omega} \rangle}{2} + U(\gamma), \quad F_2 = \langle \boldsymbol{\gamma}, \boldsymbol{\gamma} \rangle, \quad F_3 = \langle \mathbf{a}, \boldsymbol{\omega} \rangle.$$

For real motions we have $F_2 = 1$ and $F_3 = 0$. Thus, the problem of integrating equations (5.35) reduces to finding an invariant measure (the existence of which is far from being obvious) and a fourth independent integral. We consider the special case where \mathbf{a} is an eigenvector of the operator A . Under this assumption the phase flow of system (5.35) preserves the “standard”

measure on $\mathbb{R}^6 = \mathbb{R}^3\{\boldsymbol{\omega}\} \times \mathbb{R}^3\{\boldsymbol{\gamma}\}$. Suppose that the body rotates in a homogeneous force field: $U(\boldsymbol{\gamma}) = \langle \mathbf{b}, \boldsymbol{\gamma} \rangle$. If $\langle \mathbf{a}, \mathbf{b} \rangle = 0$, then equations (5.35) admit the fourth integral $F_4 = \langle A\boldsymbol{\omega}, \mathbf{b} \rangle$ and therefore can be integrated by quadratures. This case was considered by Kharlamova [313]. We indicate one more integrable case: if the force function is given by (5.31), then the equations of rotation admit the Tissèrand integral as a fourth integral (see a)). This range of questions is discussed in more detail in [332].

In conclusion we remark that comparatively few exactly solved problems are known in non-holonomic mechanics (practically complete information can be found in the books [5, 19, 39]). Even in the simplest of these problems, the behaviour of the system can be quite unexpected. Examples are provided by a skate on an inclined plane and a homogeneous ball in a vertical cylinder, which were already mentioned in § 1.2.5. A circumstantial analysis of the range of questions related to rolling of rigid bodies is contained in the book [409].

The theory of integrable Hamiltonian systems fundamentally uses the fact (which is very close to Liouville's theorem) that the foliation of a symplectic manifold into Lagrangian leaves invariantly defines on each leaf a locally affine structure (in which the trajectories become straight lines). This circumstance allows us to hope for the existence of the projective version of the theory of integrable systems on contact manifolds.

In contact geometry the role of Lagrangian foliation is played by the Legendre foliation (whose leaves are Legendre manifolds, that is, maximal integral submanifolds of the contact manifold). The contact structure of the ambient manifold invariantly defines locally projective structures on such leaves. There is the hope that these structures will allow one to produce the projective version of Liouville's theorem and use it to develop contact theory of integrable Hamiltonian systems in which Hamiltonian systems will be replaced by the theory of characteristics of general partial differential equations of the first order, and the commutativity of integrals corresponding to the commutativity of the translation group of the affine space will be replaced by the condition of projectivity of the corresponding symmetry algebra. But this theory is at present completely undeveloped.

Perturbation Theory for Integrable Systems

In nature we often encounter systems that differ from integrable ones by small perturbations. For example, the problem of the motion of the planets around the Sun can be regarded as a perturbation of the integrable problem of the motion of non-interacting points around a fixed attracting centre. Methods developed for studying such problems are united under the general name *perturbation theory*. These methods are usually simple and effective. They often enable one to describe the perturbed motion almost as completely as the unperturbed one. Some of these methods were already proposed and used by Lagrange and Laplace in their studies of the secular perturbations of the planets. The problems of justification in perturbation theory are quite difficult and began to be considered relatively recently. Many of them are far from being completely solved.

In the present chapter we consider the methods of perturbation theory that are grouped around the averaging principle and the idea of dividing motion into slow drift and rapid oscillations.

Throughout this chapter we use the following notation: ε is a small parameter, and $c_i, C_i > 0$ are constants, that is, quantities independent of ε . We apply the following convention: an appearance of c_i (or C_i) in some relation is equivalent to the assertion that there exists a constant c_i (respectively, C_i) satisfying this relation.

6.1 Averaging of Perturbations

6.1.1 Averaging Principle

If a small perturbation is imposed upon an integrable conservative system, then the quantities that were integrals in the unperturbed problem begin to slowly evolve. Over times of order 1 the evolution is small. Over times of order $1/\varepsilon$, where ε is a small parameter characterizing the magnitude of the perturbation, the evolution may be considerable (of order 1). The main

principle stated below, which is called the *averaging principle*, allows one to write down closed equations for the evolution containing only slowly changing variables.¹

We assume that the common levels of the single-valued integrals of the unperturbed integrable system are tori carrying conditionally periodic motions (as in the case of complete integrability) and that the equations of the unperturbed motion can be written in the form

$$\begin{aligned} \dot{I} &= 0, & I &\in B \subset \mathbb{R}^n, \\ \dot{\varphi} &= \omega(I), & \varphi &\in \mathbb{T}^m. \end{aligned} \tag{6.1}$$

Here $I = (I_1, \dots, I_n)$ is a set of integrals of the problem, an equation $I = \text{const}$ defines an invariant m -dimensional torus, $\varphi = (\varphi_1, \dots, \varphi_m) \bmod 2\pi$ are coordinates on this torus (phases), $\omega(I) = (\omega_1(I), \dots, \omega_m(I))$ are the frequencies of the unperturbed motion, and B is a domain in \mathbb{R}^n where the variables I are defined.

Example 6.1. If the unperturbed system describes the motion of non-interacting planets along Keplerian ellipses around the Sun attracting them, then the integrals I_j are the major semiaxes, eccentricities, inclinations, longitudes of the nodes and pericentres, while the phases φ_j are the mean anomalies of the planets. \triangle

A small perturbation of the system gives rise to small additional terms appearing in the equations of motion. In the variables I, φ the equations of the perturbed motion take the form

$$\begin{aligned} \dot{I} &= \varepsilon f(I, \varphi, \varepsilon), \\ \dot{\varphi} &= \omega(I) + \varepsilon g(I, \varphi, \varepsilon). \end{aligned} \tag{6.2}$$

The functions f and g have period 2π in φ , and ε is small. In equations (6.2) the variables I are called the *slow variables*, and the phases φ are called the *fast variables*.

In applications one is usually interested mainly in the behaviour of the slow variables. The *averaging principle* consists in replacing the system of perturbed equations (6.2) by the *averaged system*

$$\dot{J} = \varepsilon F(J), \quad F(J) = (2\pi)^{-m} \oint_{\mathbb{T}^m} f(J, \varphi, 0) d\varphi, \tag{6.3}$$

for the approximate description of the evolution of the slow variables over times of order $1/\varepsilon$ (here $d\varphi = d\varphi_1 d\varphi_2 \dots d\varphi_m$).

¹ This principle is not a theorem, but a physical proposition, that is, a vaguely stated and, strictly speaking, false assertion. Such assertions often happen to be fruitful sources for mathematical theorems.

We thus obtain a closed system for describing the slow motion, which is much simpler than the original one; for example, for a numerical integration of the new system, the step can be chosen to be $1/\varepsilon$ times larger. Therefore the averaging principle is extremely productive and is widely used in practice.

Let $I(t)$ be a slow motion in the original system, and $J(t)$ in the averaged one, $J(0) = I(0)$. According to the averaging principle, $I(t)$ is replaced by $J(t)$. To justify this recipe (which does not always yield a correct answer) we must find conditions which ensure that $|I(t) - J(t)| \rightarrow 0$ for $0 \leq t \leq 1/\varepsilon$ as $\varepsilon \rightarrow 0$. If the last relation holds, then it is desirable to have an upper estimate of $|I(t) - J(t)|$ for $0 \leq t \leq 1/\varepsilon$. Sometimes such estimates can also be established for much longer time intervals. These problems are still far from being completely solved; they are discussed in the next subsections.

Example 6.2. Consider the system of equations

$$\dot{I} = \varepsilon(a + b \cos \varphi), \quad \dot{\varphi} = \omega$$

and the corresponding averaged system

$$\dot{J} = \varepsilon a.$$

Here

$$\begin{aligned} I(t) &= I_0 + \varepsilon at + \varepsilon b[\sin(\omega t + \varphi_0) - \sin \varphi_0]/\omega, \\ J(t) &= I_0 + \varepsilon at. \end{aligned}$$

The solutions of the exact system oscillate about the solutions of the averaged system with an amplitude of order ε and with frequency ω (Fig. 6.1). *Averaging* amounts to dropping the purely periodic term on the right-hand side of the equation. This term has the same order as the remaining term. But it oscillates and causes only small oscillations of the solution. The remaining term causes a drift which over time $1/(\varepsilon a)$ changes I by 1.

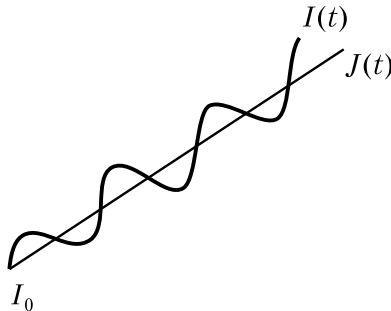

Fig. 6.1.

△

The averaging principle is based on the idea that in the general case, too, the oscillating terms discarded in averaging cause only small oscillations, which are superimposed on the drift described by the averaged system.

The averaging principle stated above was used by Lagrange and Laplace in the theory of secular perturbations of the orbits of the planets. After their works this principle became a standard method in celestial mechanics. Later this principle was rediscovered by van der Pol, who used it for solving problems in the theory of nonlinear oscillations. Extensive application of the averaging principle in oscillation theory was stimulated by the works of Mandel'shtam, Papaleksi, Krylov, Bogolyubov, and Mitropol'skij. The history of the principle is fairly intricate, it is expounded in the introductory sections of the monograph [426]. At present the averaging principle is used in many variants (sometimes also under different names) in many areas of applied research.

Now suppose that in the equations of the unperturbed motion the frequencies are identically commensurable, that is, they satisfy one or several relations of the form $(k, \omega) \equiv 0$, where $k = (k_1, \dots, k_m) \in \mathbb{Z}^m \setminus \{0\}$ and $(k, \omega) = k_1\omega_1 + \dots + k_m\omega_m$. Then the trajectories of the unperturbed motion on the torus \mathbb{T}^m fill up tori of lower dimension, and the averaging over the entire torus \mathbb{T}^m cannot, generally speaking, correctly describe the motion. Another argument is that the expansion of the right-hand sides of the perturbed system in the Fourier series contains non-oscillating harmonics, which cannot be discarded for any good reasons. If the frequencies are close to commensurability over a sufficiently long time, then the averaging over the entire torus may also not be applicable. In these cases, which are said to be resonant, the following procedure is used, which is called *partial averaging*. Suppose that we have one or several *resonance relations*, that is, equalities of the form $(k, \omega) = 0$ with irreducible integer vectors of coefficients k . We denote by K the minimal sublattice of the integer lattice \mathbb{Z}^m containing these vectors such that if some vector of the form dl , $d \in \mathbb{N}$, $l \in \mathbb{Z}^m$, belongs to K , then l also belongs to K . Let r denote the rank of K . A harmonic $\exp(i(k, \varphi))$ is said to be *resonant* if $k \in K$. The system (6.2) *partially averaged* taking into account the given system of resonance relations (or simply *resonances*) is by definition the system

$$\begin{aligned} \dot{J} &= \varepsilon F_K(J, \varphi), \\ \dot{\varphi} &= \omega(J) + \varepsilon G_K(J, \varphi), \end{aligned} \tag{6.4}$$

where F_K and G_K are the sums of resonant harmonics in the Fourier series of the functions $f(I, \varphi, 0)$ and $g(I, \varphi, 0)$.

To justify the term “partial averaging” we perform the change of phases $\vartheta = R\varphi$ in the equations of the perturbed motion, where R is an integer unimodular (with determinant 1) matrix whose first r rows belong to K (such a matrix exists according to [164]). Let $\gamma = (\gamma_1, \dots, \gamma_r)$ denote the first r components of ϑ , and $\chi = (\chi_1, \dots, \chi_{m-r})$ the remaining components. Averaging the resulting system over χ we arrive at equations equivalent to (6.4).

This argument also shows that to describe the variation of J in (6.4) it suffices to consider the system of $n + r$ equations for J , γ . The variables J are slow, and the variables γ are semifast: they evolve slowly near the points of the phase space where the given resonance relations hold, and fast far from these points.

Example 6.3. Consider the system of equations

$$\begin{aligned} \dot{I}_1 &= -\varepsilon \sin(\varphi_1 - \varphi_2), & \dot{I}_2 &= \varepsilon[\cos(\varphi_1 - \varphi_2) + \sin \varphi_2], \\ \dot{\varphi}_1 &= 1 + I_1, & \dot{\varphi}_2 &= 1. \end{aligned}$$

We introduce $\gamma = \varphi_1 - \varphi_2$. The phase portrait of the problem on the plane I_1 , γ is shown in Fig. 6.2. The oscillatory domain has width $4\sqrt{\varepsilon}$. The independent averaging over φ_1 and φ_2 for $I_1(0) = 0$, $\gamma(0) = 0$ leads over time $1/\varepsilon$ to an error of order 1. The partial averaging taking into account the resonance $\omega_1 - \omega_2 = 0$ produces the system

$$\dot{J}_1 = -\varepsilon \sin \gamma, \quad \dot{J}_2 = \varepsilon \cos \gamma, \quad \dot{\gamma} = J_1,$$

which describes the evolution of I on times $1/\varepsilon$ with an accuracy of order ε .

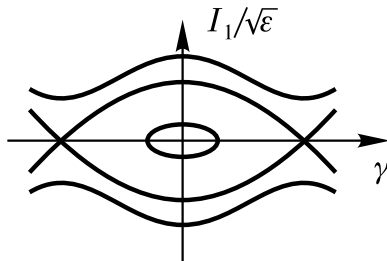

Fig. 6.2.

△

6.1.2 Procedure for Eliminating Fast Variables. Non-Resonant Case

The main role in all problems connected with the averaging principle is played by changes of variables that enable one to eliminate, with the required accuracy, the fast phases from the equations of perturbed motion and thus separate the slow motion from the fast one. These changes of variables reduce the original system of equations to the averaged one in the first approximation. They were constructed by Lindstedt, Bohlin, Delaunay, Newcomb, Poincaré, von Zeipel, Krylov, and Bogolyubov.² We now describe the construction of

² Such changes of variables were considered by Newcomb [476] for Hamiltonian systems of celestial mechanics, by Lindstedt [388] for not necessarily Hamiltonian

these changes of variables (in the non-conservative case; the conservative case is considered in § 6.2).

The required change of variables $(I, \varphi) \mapsto (J, \psi)$ is sought in the form of the formal series

$$\begin{aligned} I &= J + \varepsilon u_1(J, \psi) + \varepsilon^2 u_2(J, \psi) + \cdots, \\ \varphi &= \psi + \varepsilon v_1(J, \psi) + \varepsilon^2 v_2(J, \psi) + \cdots, \end{aligned} \quad (6.5)$$

where the functions u_j and v_j have period 2π in ψ . We try to find the u_j and v_j so that the right-hand sides of the equations for the new variables do not contain the fast phases, that is, the equations have the form

$$\begin{aligned} \dot{J} &= \varepsilon F_0(J) + \varepsilon^2 F_1(J) + \cdots, \\ \dot{\psi} &= \omega(J) + \varepsilon G_0(J) + \varepsilon^2 G_1(J) + \cdots. \end{aligned} \quad (6.6)$$

Suppose that the right-hand sides of the equations of the perturbed motion (6.2) are analytic in all the variables. Substituting the new variables into these equations, substituting the expressions (6.6) of \dot{J} and $\dot{\psi}$ into the resulting relations, and equating the terms of the same order in ε we obtain the following system of relations:

$$\begin{aligned} F_0(J) &= f(J, \psi, 0) - \frac{\partial u_1}{\partial \psi} \omega, \\ G_0(J) &= g(J, \psi, 0) + \frac{\partial \omega}{\partial J} u_1 - \frac{\partial v_1}{\partial \psi} \omega, \\ F_j(J) &= X_j(J, \psi) - \frac{\partial u_{j+1}}{\partial \psi} \omega, \quad j \geq 1, \\ G_j(J) &= Y_j(J, \psi) + \frac{\partial \omega}{\partial J} u_{j+1} - \frac{\partial v_{j+1}}{\partial \psi} \omega, \quad j \geq 1. \end{aligned} \quad (6.7)$$

The functions X_j, Y_j are determined by the terms $u_1, v_1, \dots, u_j, v_j$ in the expansion (6.5).

To write down the solution of system (6.7) obtained above we introduce additional notation. Suppose that the function $h(J, \psi)$ has period 2π in ψ . We write down its expansion in the Fourier series:

$$h(J, \psi) = h_0(J) + \sum_{k \neq 0} h_k(J) \exp(i(k, \psi)).$$

We set

$$\langle h \rangle^\psi = h_0(J), \quad \{h\}^\psi = \sum'_{k \neq 0} \frac{h_k}{i(k, \omega)} \exp(i(k, \psi)). \quad (6.8)$$

(but reversible) weakly nonlinear systems, by Poincaré [41] for Hamiltonian systems of the general form, by Krylov and Bogolyubov [360] for non-Hamiltonian weakly nonlinear systems, and by Bogolyubov and Zubarev [117] for nonlinear single-frequency systems.

The prime over the sum symbol in (6.8) means that the summation is carried out over the k such that the harmonic $\exp(i(k, \varphi))$ is really involved in the Fourier series of the function h , that is, $h_k \neq 0$ in the domain under consideration. Obviously,

$$\left(\frac{\partial}{\partial \psi} \{h\}^\psi\right) \omega = h - \langle h \rangle^\psi.$$

The operator $\{\cdot\}^\psi$ is called the *integration operator*. It is not defined when the denominators in (6.8) vanish or are very small compared to the numerators. The difficulties connected with the presence of these *small denominators* (or *small divisors*) are of fundamental importance in perturbation theory. But we temporarily forget about them and assume that the integration operator can be applied to all the functions occurring below. Then the solution of system (6.7) is given by the formulae

$$\begin{aligned} F_0(J) &= \langle f(J, \psi, 0) \rangle^\psi, \\ u_1(J, \psi) &= \{f(J, \psi, 0)\}^\psi + u_1^0(J), \\ G_0(J) &= \left\langle g(J, \psi, 0) + \frac{\partial \omega}{\partial J} u_1(J, \psi) \right\rangle^\psi, \\ v_1(J, \psi) &= \left\{ g(J, \psi, 0) + \frac{\partial \omega}{\partial J} u_1(J, \psi) \right\}^\psi + v_1^0(J), \\ F_j &= \langle X_j \rangle^\psi, \\ u_{j+1} &= \{X_j\}^\psi + u_{j+1}^0, \quad j \geq 1, \\ G_j &= \left\langle Y_j + \frac{\partial \omega}{\partial J} u_{j+1} \right\rangle^\psi, \\ v_{j+1} &= \left\{ Y_j + \frac{\partial \omega}{\partial J} u_{j+1} \right\}^\psi + v_{j+1}^0, \quad j \geq 1. \end{aligned} \tag{6.9}$$

Here the $u_j^0(J)$ and $v_j^0(J)$ are arbitrary functions. One usually chooses $u_j^0 = v_j^0 = 0$.

If the series for the change of variables (6.5) are truncated at the terms of order $r \geq 1$, then we obtain a change of variables which reduces the equations of the perturbed motion to the form

$$\begin{aligned} \dot{J} &= \varepsilon F_\Sigma(J, \varepsilon) + \varepsilon^{r+1} \alpha(J, \psi, \varepsilon), \\ \dot{\psi} &= \omega(J) + \varepsilon G_\Sigma(J, \varepsilon) + \varepsilon^{r+1} \beta(J, \psi, \varepsilon). \end{aligned}$$

Thus, as a result the dependence on the phases is deferred to the terms of order ε^{r+1} . If these terms are discarded, then the system of equations for J splits off. If its solutions are found, then the evolution of the phase ψ can be found by a quadrature. Returning to the original variables we see that the evolution of I amounts to a slow drift (described by the equation for J) onto which small rapid oscillations are superimposed (described by the change of

variables), exactly as in Example 6.1 and in Fig. 6.1. The evolution of φ is represented as a rotation with slowly changing frequency, onto which oscillations are also superimposed. In the first approximation this procedure leads to the averaged system (with additional equations approximately describing the evolution of the phases).

In the foregoing discussion we have been assuming that in the formulae for the change of variables the denominators $(k, \omega(J))$ do not vanish in the domain considered. This assumption holds for single-frequency systems with non-vanishing frequency, for systems with constant incommensurable frequencies, for systems with finitely many harmonics in the perturbation, and in certain other cases (see § 6.1.4–6.1.6 below). But for general multi-frequency systems this condition fails. There are two difficulties here.

First, in the general case the denominators $(k, \omega(J))$, $k \in \mathbb{Z}^m \setminus \{0\}$, vanish on an everywhere dense set of values of J , so that formulae (6.8), (6.9) do not even allow one to define the u_j, v_j . This difficulty is circumvented by the following modification of the change of variables. The perturbing functions $\varepsilon f, \varepsilon g$ are represented in the form

$$\varepsilon f = f^{(1)} + f^{(2)} + \dots, \quad \varepsilon g = g^{(1)} + g^{(2)} + \dots,$$

where the $f^{(m)}, g^{(m)}$ are trigonometric polynomials in φ whose absolute values are bounded above by quantities of order ε^m . The procedure for eliminating the fast phases is carried out as if the $f^{(m)}, g^{(m)}$ were the terms of order ε^m in the expansion of the perturbation in ε (without taking into account that the $f^{(m)}/\varepsilon^m$ and $g^{(m)}/\varepsilon^m$ themselves depend on ε). Then only finitely many small denominators appear at each step of the procedure. Correspondingly, the functions u_j, v_j are undefined only on finitely many resonant surfaces $(k, \omega(J)) = 0$, whose number depends on ε and the index j . As a result, in each finite approximation the map $(J, \psi) \mapsto (I, \varphi)$ is undefined on finitely many surfaces (whose number depends on ε and the order of the approximation). Outside some neighbourhood of these surfaces (usually of width of order $\sqrt{\varepsilon}$) the differences $|I - J|$ and $|\varphi - \psi|$ prove to be sufficiently small (usually also of order $\sqrt{\varepsilon}$) and the map $(J, \psi) \mapsto (I, \varphi)$ indeed defines a change of variables. The substitution of the corresponding new variables into the equations allows one to defer the dependence on the phases to the terms of higher order in ε .

The second difficulty is that the frequencies $\omega(I)$ themselves slowly vary in the course of evolution. Therefore on a time interval of order $1/\varepsilon$ the point may repeatedly cross the neighbourhoods of the resonant surfaces. Consequently, even the change of variables of the first approximation is in general undefined along the entire trajectory on a time interval $1/\varepsilon$. However, this change of variables is the main tool of analysis of the motion between the resonances. The phenomena occurring at crossing resonant surfaces are considered below in §§ 6.1.7–6.1.8. Roughly speaking, here the situation is as follows: the total measure of the resonant domains proves to be small; hence for most of the initial data the motion in these domains cannot strongly affect the evolution, and the averaging principle enables one to correctly describe most of the trajectories.

Remark 6.1. There exist different versions of constructing a change of variables separating the fast and slow motions. In particular, such a change of variables can be sought not in the form of a series as above, but as a composition of successive changes of variables. The first change of variables is defined by the formulae

$$I = J + \varepsilon u_1(J, \psi), \quad \varphi = \psi + \varepsilon v_1(J, \psi),$$

where u_1, v_1 are the first terms of the series (6.5) defined above. The equations of the perturbed motion for the new variables contain the phases in the terms of order ε^2 . Then a similar change of variables is performed, which defers the dependence on the phases to the terms of order ε^3 , and so on. This method produces the same formal change of variables (6.5), but technically it often proves to be more convenient. For Hamiltonian perturbations the method of successive changes of variables has the remarkable property of quadratic convergence: the second change of variables defers the dependence on the phases to the terms of order ε^4 , the third to the terms of order ε^8 , and so on (see §6.2.2.C below).

Remark 6.2. Another version of the procedure for separating the motions is obtained on the basis of the following consideration. A transformation $(I, \varphi) \mapsto (J, \psi)$ of the form (6.5) is the shift transformation by “time” ε for a certain formal system of differential equations

$$\frac{dy}{d\varepsilon} = W(y, \varepsilon), \quad W = W_1(y) + \varepsilon W_2(y) + \dots, \quad y = (J, \psi).$$

Conversely, every such system of equations generates a shift transformation of the form (6.5). Therefore, instead of the functions u_j, v_j involved in (6.5) we can seek the functions W_j defining the corresponding system of differential equations. The resulting procedure has the convenient feature that it provides fairly simple general formulae for higher approximations. See the details in [256].

Remark 6.3. A method for separating the motions called *continuous averaging* was proposed in [48, 587, 588, 589]. This method is used to construct a flow in the function space of systems of the form (6.2) such that the terms of equations depending on the fast phases are decreasing along this flow. Systems on the same trajectory of the flow are obtained from one another by a near-identity change of variables. The flow in the space of systems is described by a system of partial differential equations. Estimates of solutions of this system enable one to obtain estimates of the accuracy of separation of the motions. The method of successive changes of variables (see Remark 6.1 above) is used for constructing, in fact, a difference approximation (with respect to the variable along the flow) for the solutions of the system of equations of the continuous averaging. For the present the method of continuous averaging has been developed in detail for single-frequency systems ($m = 1$) and for multi-frequency systems with constant frequencies [48, 515].

6.1.3 Procedure for Eliminating Fast Variables. Resonant Case

Suppose that we are given a sublattice K of integer vectors defining the possible resonances. We try to find a change of variables $(I, \varphi) \mapsto (J, \psi)$ so that the right-hand sides of the equations of the perturbed motion in the new variables depend on the fast phases only via the combinations (k, ψ) , $k \in K$. We seek the change of variables in the form of series (6.5).

The equations for J, ψ must have the form

$$\begin{aligned} \dot{J} &= \varepsilon F_0(J, \gamma) + \varepsilon^2 F_1(J, \gamma) + \dots, \\ \dot{\psi} &= \omega(J) + \varepsilon G_0(J, \gamma) + \dots, \end{aligned} \tag{6.10}$$

where $\gamma = (\gamma_1, \dots, \gamma_r)$ are semifast variables (independent combinations of the phases ψ with coefficients in K) and r is the rank of K . We also introduce the fast variables $\chi = (\chi_1, \dots, \chi_{m-r})$ such that $(\gamma, \chi) = R\psi$, where R is the unimodular matrix introduced at the end of §6.1.1. Substituting the new variables into the equations of the perturbed motion, expressing $\dot{J}, \dot{\psi}$ according to (6.10), and equating the terms of the same order in ε we obtain a system of relations of the form (6.7), but the functions F_j, G_j on its right-hand sides now depend on J and γ . A particular solution³ of this system is given by the formulae

$$\begin{aligned} F_0(J, \gamma) &= \langle f(J, \psi, 0) \rangle^\chi, \\ u_1(J, \psi) &= \{f(J, \psi, 0) - F_0(J, \gamma)\}^\psi + u_1^0(J), \\ G_0(J, \gamma) &= \left\langle g(J, \psi, 0) + \frac{\partial \omega}{\partial J} u_1(J, \psi) \right\rangle^\chi, \\ v_1(J, \psi) &= \left\{ g(J, \psi, 0) + \frac{\partial \omega}{\partial J} u_1(J, \psi) - G_0(J, \gamma) \right\}^\psi + v_1^0(J), \\ F_j &= \langle X_j \rangle^\chi, \\ u_{j+1} &= \{X_j - F_j\}^\psi + u_{j+1}^0(J), \quad j \geq 1, \\ G_j &= \left\langle Y_j + \frac{\partial \omega}{\partial J} u_{j+1} \right\rangle^\chi, \\ v_{j+1} &= \left\{ Y_j + \frac{\partial \omega}{\partial J} u_{j+1} - G_j \right\}^\psi + v_{j+1}^0(J), \quad j \geq 1. \end{aligned}$$

Here the symbol $\langle \cdot \rangle^\chi$ denotes averaging over χ (first ψ must be expressed in terms of γ, χ), the symbol $\{ \cdot \}^\psi$, as in §6.1.2, denotes application of the integration operator (6.8), and the u_j^0, v_j^0 are arbitrary functions of J . In these formulae the denominators (k, ω) appear only for $k \notin K$.

Truncating the series of the change of variables at the terms of order r we obtain a system of equations in which the dependence on the fast phases is deferred to the terms of order ε^{r+1} . Discarding these terms we obtain a truncated

³ In the general solution the u_j^0, v_j^0 depend on J, γ , and the F_j, G_j change.

system, which must be applied for describing the motion in a neighbourhood of the resonant surfaces $(k, \omega(J)) = 0$, $k \in K$. In the first approximation this system coincides with system (6.4) partially averaged taking into account the given resonances (but we must choose $u_1^0 = 0$).

6.1.4 Averaging in Single-Frequency Systems

We consider the system of equations of the perturbed motion (6.2) which has only one phase. We assume that the frequency $\omega(I)$ of variation of this phase does not vanish: $\omega(I) > c^{-1} > 0$, $c = \text{const}$. In this case the system is also called a *system with rapidly rotating phase*. Such systems are among the main objects of perturbation theory. Here are some examples:

- a one degree of freedom oscillatory system upon which a small non-conservative perturbation is imposed (for example, a pendulum with a small perturbing torque);
- a one degree of freedom oscillatory system whose parameters evolve slowly (for example, a pendulum with slowly changing length [600]);
- a system acted upon by a rapidly oscillating perturbation periodic in time;
- motion in the two-body problem in the presence of a small perturbation (small propulsive force [230], resistance of medium);
- rotation of a rigid body around the centre of mass in the presence of a small perturbing torque that is independent of the position of the body in space (propulsive force of jet engines mounted on the body, resistance of medium [61, 452], see also Example 6.12); here the unperturbed motion is governed by the Euler–Poinsot equations and has two fast phases, but one of them, characterizing the body’s precession around the vector of angular momentum, is not involved in the equations;
- motion of a charged particle in a magnetic field that changes only slightly over the length of the Larmor radius [117, 482]; in the unperturbed system the magnetic field is constant and the motion takes place along the Larmor circle drifting along the force lines of the field, and the role of the fast phase is played by the angle coordinate of the point on this circle.

Many examples of using averaging for analysis of motion in single-frequency systems are contained in [600].

In the single-frequency case the justification of the averaging principle is practically complete. Below we present the results on the accuracy of averaging over time intervals of order $1/\varepsilon$, on the properties of higher-order approximations of the procedure for eliminating the fast variables, and on the connections between the integral manifolds (stationary points, cycles, invariant tori) of the exact and averaged systems.

Remark 6.4. In what follows, we omit the natural conditions of continuability of solutions in the statements of the theorems: we assume throughout that

the solution $J(t)$ of the averaged system for $0 \leq t \leq 1/\varepsilon$ does not approach too closely the boundary of the domain where the system is defined.

Suppose that in the equations of the perturbed motion (6.2) the frequency ω and the perturbations f, g are smooth functions in their domain of definition $B \times S^1 \times [0, \varepsilon_0]$, and their absolute values, together with those of their first derivatives, are bounded above by a constant C .

Theorem 6.1. *The difference between the slow motion $I(t)$ in the exact system and $J(t)$ in the averaged system remains small over time $1/\varepsilon$:*

$$|I(t) - J(t)| < c_1 \varepsilon \quad \text{if} \quad I(0) = J(0), \quad 0 \leq t \leq 1/\varepsilon,$$

where c_1 is a constant depending on the constants c and C .

◁ The change of variables of the first approximation in § 6.1.2 differs from the identity by a quantity of order ε . It reduces the exact system to the averaged one with an addition of a small (of order ε^2) perturbation. Over time $1/\varepsilon$ this perturbation can change the value of the slow variable, compared to its value in the averaged system, only by a quantity of order ε . Returning to the original variables we obtain the result of the theorem. ▷

This theorem was proved by Fatou and, by another method, by Mandel'shtam and Papaleksi [426]. The proof given above, which is based on the elimination of the fast phase by a change of variables, is due to Bogolyubov.⁴

If the perturbed system is analytic, then the procedure of § 6.1.2 enables one to eliminate the phase from its right-hand sides up to any finite order in ε . However, the series thus obtained in general diverge, so that the complete elimination of the phase and separation of the fast and slow motions cannot be achieved.⁵ It turns out that the elimination of the phase can be carried out with exponentially small error. In the general case this error is in principle unavoidable in any version of perturbation theory. We now state the precise assertion about the elimination of the phase. Suppose that the right-hand sides of the perturbed system can be analytically continued to the complex δ -neighbourhood of the domain of definition of the system and this continuation remains bounded in absolute value by the constant C . Suppose that $|\omega| > c^{-1} > 0$ in this neighbourhood.

Theorem 6.2 ([455]). *There is an analytic change of variables*

$$I = J + \varepsilon u(J, \psi, \varepsilon), \quad \varphi = \psi + \varepsilon v(J, \psi, \varepsilon), \quad |u| + |v| < c_1, \quad (6.11)$$

⁴ More precisely, Bogolyubov used this method to prove a similar theorem for systems of a more general form (which he called systems in standard form, see § 6.1.5), of which the single-frequency systems and systems with perturbation that is quasi-periodic in time are special cases [15, 16].

⁵ With a natural choice of arbitrary functions involved in the series for the change of variables in § 6.1.2 these series prove to be of Gevrey class 1 in ε , that is, the n th term is $O(\varepsilon^n n!)$, see [517]; this estimate is best possible.

reducing the equations of the perturbed motion to the form

$$\begin{aligned}\dot{J} &= \varepsilon(\Phi(J, \varepsilon) + \alpha(J, \psi, \varepsilon)), \\ \dot{\psi} &= \Omega(J, \varepsilon) + \varepsilon\beta(J, \psi, \varepsilon),\end{aligned}\tag{6.12}$$

$$|\alpha| + |\beta| < c_2 \exp(-c_3^{-1}/\varepsilon), \quad |\Phi - \langle f \rangle| + |\Omega - \omega| < c_4\varepsilon,$$

where the c_i are positive constants depending on c , C , δ , and ε_0 .⁶

The exponent in the preceding theorem satisfies the following best-possible estimate [589]. Consider the motion in the averaged system in the imaginary direction of time. Equivalently, consider the motion for real t in the system

$$\dot{J} = i\varepsilon F(J), \quad F = \langle f \rangle^\varphi,$$

where i is the imaginary unit. Suppose that for the initial conditions $J_0 \in B$ the solution $J(\varepsilon t)$ of this system satisfying $J(0) = J_0$ is defined on the time interval $0 \leq \varepsilon t \leq T(J_0)$, is analytic, and satisfies $\omega(J(\varepsilon t)) \neq 0$ and $\left| \operatorname{Re} \int_0^{T(J_0)} \omega(J(\tau)) d\tau \right| < \Psi = \text{const}$. Then we can take $|\alpha| + |\beta| < c_2 \exp(-\Psi/\varepsilon)$ in Theorem 6.2.

The exponential additional term is unavoidable, since when the image of any curve that is initially close to the circle $I = \text{const}$ is evolving under the action of the perturbed phase flow, its projection onto the space of slow variables is increasing, generally speaking, not slower than $\varepsilon t c_5 \exp(-c_6^{-1}/\varepsilon)$. However, in the cases where the solutions of the averaged system leave sufficiently quickly the domain in which the problem is considered, this exponentially slow growth does not have enough time to become an obstruction to the complete separation of the fast and slow motions, as shown by the following assertion.

Theorem 6.3 (cf. [245]). *Suppose that the field of phase velocities of the averaged system can be rectified (that is, it can be transformed into a field of parallel vectors of the same length) by an analytic diffeomorphism of the domain B . Then there is an analytic change of variables of the form (6.11) reducing the equations of the perturbed motion to the form (6.12) with $\alpha \equiv \beta \equiv 0$.*

(If the system is smooth but not analytic, and the field of phase velocities of the averaged system can be rectified, then the fast and slow motions can be separated by a smooth change of variables [291]).

Studying the averaged system one can often establish the existence of limit cycles and invariant tori of the original system and approximately calculate them.

⁶ The notation for the constants is chosen so that the estimates are preserved as c , C , c_i increase.

Theorem 6.4 ([16]). *Suppose that the averaged system has a non-degenerate⁷ equilibrium position. Then the exact system has a limit cycle along which the slow variables vary within a neighbourhood of this equilibrium position of size of order ε . If all the eigenvalues of the averaged system linearized about this equilibrium position have negative real parts, then the cycle is orbitally asymptotically stable. If the real part of one of the eigenvalues is positive, then the cycle is unstable.*

◁ We introduce the phase as a new independent variable (new time). We consider two maps of \mathbb{R}^n into itself: T_0 , the shift map by (new) time 2π for the averaged system, and T_1 , the same map for the exact system transformed by the change of variables of the first approximation constructed in §6.1.2. The maps T_0 and T_1 displace a point by a quantity of order ε , while these maps differ from each other by a quantity of order ε^2 . The map T_0 has a non-degenerate fixed point J_* . By the implicit function theorem, for sufficiently small ε the map T_1 has a fixed point $J = J_* + O(\varepsilon)$, which obviously serves as the initial condition for the required limit cycle. ▷

Example 6.4. The *van der Pol equation*

$$\ddot{x} = -x + \varepsilon(1 - x^2)\dot{x}$$

describes oscillations with a small nonlinear “friction” which is negative for large amplitudes, and positive for small ones. The unperturbed equation $\ddot{x} = -x$ can be written in the standard form $\dot{I} = 0$, $\dot{\varphi} = -1$, where $2I = x^2 + \dot{x}^2$ and $\varphi = \arg(x + i\dot{x})$. The equation for I in the perturbed motion has the form

$$\dot{I} = \varepsilon(1 - x^2)\dot{x}^2 = 2\varepsilon I(1 - 2I \cos^2 \varphi) \sin^2 \varphi.$$

The averaged equation is

$$\dot{J} = \varepsilon \left(J - \frac{J^2}{2} \right).$$

It has a repelling equilibrium $J = 0$, and an attracting one $J = 2$. To the equilibrium $J = 0$ there corresponds the equilibrium $x = 0$ of the original equation. By Theorem 6.4 above, to the equilibrium $J = 2$ there corresponds a stable limit cycle of the original equation, which is close to the circle $x^2 + \dot{x}^2 = 4$ (see Fig. 6.3). △

Example 6.5 (Stability of the upper position of a *pendulum with vibrating suspension point* [568, 115, 302]). The equation of motion of a pendulum whose point of suspension performs vertical sinusoidal oscillations in the presence of viscous friction has the form

$$\ddot{\vartheta} + \nu \dot{\vartheta} + (g - a\omega^2 \sin \omega t)l^{-1} \sin \vartheta = 0,$$

⁷ An equilibrium position is said to be *non-degenerate* if the system linearized about it has no zero eigenvalues.

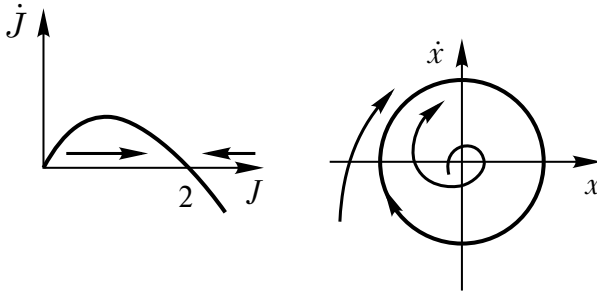

Fig. 6.3.

where ϑ is the angle of deviation of the pendulum from the vertical, a and ω are the amplitude and the frequency of the oscillations of the suspension point, l is the length of the pendulum, g the acceleration of gravity, and ν the damping coefficient. We show that for a sufficiently high frequency and small amplitude of the oscillations of the suspension point the upper equilibrium position of the pendulum is stable (the exposition below follows [158]). We assume that $a = a_0\varepsilon$ and $\omega = \omega_0/\varepsilon$, where a_0 and ω_0 are quantities of order 1, and ε is small. We write down the equations of motion so that their conservative part has the canonical Hamiltonian form:

$$\begin{aligned} \vartheta' &= \varepsilon \frac{\partial H}{\partial p}, & p' &= -\varepsilon \frac{\partial H}{\partial q} - \varepsilon \nu (p - a_0 \omega_0 l \sin \tau \sin \vartheta), \\ H &= \frac{1}{2} \left(\frac{p}{l} - a_0 \omega_0 \sin \tau \sin \vartheta \right)^2 - gl \cos \vartheta. \end{aligned}$$

Here $\tau = t/\varepsilon$ is the new time, prime denotes differentiation with respect to τ , and p is the momentum canonically conjugate to the angle ϑ . The system averaged over τ has the form

$$\begin{aligned} \vartheta' &= \varepsilon \frac{\partial \mathcal{H}}{\partial p}, & p' &= -\varepsilon \frac{\partial \mathcal{H}}{\partial q} - \varepsilon \nu p, \\ \mathcal{H} &= \frac{1}{2} \frac{p^2}{l^2} + V, & V &= \frac{1}{4} a_0^2 \omega_0^2 \sin^2 \vartheta - gl \cos \vartheta. \end{aligned}$$

The function V is called the effective potential energy. We set $K^2 = gl/\omega_0^2 a_0^2$. At the point $\vartheta = \pi$ corresponding to the upper equilibrium position of the pendulum, the function V has a non-degenerate minimum for $K < 1/\sqrt{2}$, and a non-degenerate maximum for $K > 1/\sqrt{2}$. By Theorem 6.4, for damping $\nu \neq 0$ and for sufficiently small ε , the upper position of the original pendulum for these values of K is stable or unstable, respectively.⁸

⁸ If $\nu = 0$ and $K > 1/\sqrt{2}$, then the equilibrium is unstable. If $\nu = 0$ and $K < 1/\sqrt{2}$, then the equilibrium is stable, but the proof of this fact requires new ideas

The phenomenon of stabilization of the upper position of the pendulum with vibrating suspension point was discovered by Stephenson [568] (in the linear setting), Bogolyubov [115], and Kapitsa [302]. Later the possibility of stabilization by vibration was studied in a series of papers (see the references in [426]), among which the best-known is the paper of Chelomei [168] on enhancing the stability of elastic systems. Other examples of the effect of vibrations on stability are described in [113, 169]. Stability of the stationary motions of a spherical pendulum with vibrating suspension point was studied in [410]. \triangle

If the averaged system has a limit cycle, and the multipliers of the system linearized about this cycle do not lie on the unit circle (except for one of them which corresponds to the shift along the cycle and is equal to 1), then the exact system has a two-dimensional *invariant torus*, which is stable or unstable together with the cycle and along which the slow variables evolve within a neighbourhood of this limit cycle of size of order ε ; see [16, 360]. The procedure for eliminating the fast variable enables one to obtain a formal expansion of such an invariant torus in a series in ε . For that it is sufficient to substitute the expansion of the limit cycle of system (6.6) describing the slow motion into the expansion of the change of variables (6.5). The resulting series are as a rule divergent (see Proposition 6.1 and Example 6.6 below). However, they have asymptotic nature: by truncating these series at the terms of order ε^r we obtain an approximation for the invariant torus to within $O(\varepsilon^{r+1})$.

The motion on the two-dimensional invariant torus created from a cycle of the averaged system is characterized by the *rotation number* introduced by Poincaré: $\mu(\varepsilon) = \lim_{t \rightarrow +\infty} \vartheta(t)/\varphi(t)$, where $(\vartheta, \varphi) \bmod 2\pi$ are coordinates on the torus [9]. If the rotation number is irrational, then the motion is conditionally periodic and each trajectory winds around the torus everywhere densely. If the rotation number is rational, then there exist cycles on the torus; if the cycles are non-degenerate, then their number is even (half of them are stable, and half unstable), and the other trajectories are attracted to them as $t \rightarrow \pm\infty$. In a generic system the rotation number $\mu(\varepsilon)$ is a continuous piecewise-constant function of ε on an open everywhere dense set (similar to *Cantor's staircase*, but the total relative measure of the constancy intervals on the segment $[0, \varepsilon_0]$ tends to zero as $\varepsilon_0 \rightarrow 0$). The existence of constancy intervals is related to the existence of non-degenerate cycles on the torus: for small changes in ε such cycles do not vanish and therefore the rotation number does not change. In a generic system, as $\varepsilon \rightarrow 0$ an infinite sequence of bifurcations of births and deaths of cycles takes place on the torus. All these phenomena are not detected by the formal procedure of perturbation theory.

(see §6.3.6.B). Application of the procedure for eliminating the fast variables in each approximation leads to a stable equilibrium with purely imaginary eigenvalues.

Note that in an analytic system the limit cycle described in Theorem 6.4 that is born out of an equilibrium of the averaged system is analytic and depends analytically on ε (this can be seen from the proof of Theorem 6.4). The situation is completely different when a torus is born out of a cycle of the averaged system.

Proposition 6.1 ([360]). *An invariant torus of the perturbed system is as a rule (in the generic case) not analytic in the parameter ε . For an open everywhere dense set of values of ε the torus has only finitely many (but increasingly many as ε decreases) derivatives with respect to the phase variables.*

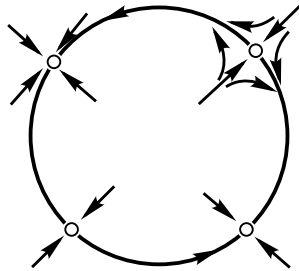

Fig. 6.4.

◁ Suppose that for some $\varepsilon = \varepsilon_*$ there exists an asymptotically orbitally stable invariant torus, the rotation number $\mu(\varepsilon_*)$ is rational, and the corresponding cycles on the torus are non-degenerate. For simplicity we consider the case of three-dimensional phase space. The section of the torus by a plane $\varphi = \text{const}$ is shown in Fig. 6.4 borrowed from [438]. If we linearize the perturbed system about a cycle and reduce it to a system with constant coefficients (according to the Floquet–Lyapunov theory), then an unstable cycle turns into a saddle, and a stable cycle into a node. The invariant torus is composed of the outgoing whiskers of the saddles connected at the nodes. It is clear that this picture is preserved under a small change in ε . But at a node all the curves in Fig. 6.4 have as a rule finitely many derivatives, except for four of them, which we call principal. This follows already from the linear theory: with respect to the principal axes the phase curves have the form $y = |cx|^{\lambda_1/\lambda_2}$, where λ_1 and λ_2 are the eigenvalues of the reduced linearized system, λ_1 characterizes the rate of attraction by the torus of trajectories from the ambient space, and λ_2 the rate with which the trajectories on the torus approach each other. Since the sections of the outgoing whiskers of the saddles may not be simultaneously principal curves of the nodes, the torus has finite smoothness. However, this smoothness is very high and is rapidly increasing as ε decreases, since $\lambda_1/\lambda_2 > c_1^{-1} \exp(c_2^{-1}/\varepsilon)$. (This follows from Theorem 6.2: if an exponentially small term is added to the system, then all the trajectories on the torus become cycles.)

Furthermore, if for arbitrarily small ε the torus can be non-analytic in the phase variables, then it is also not analytic in ε . Indeed, as mentioned above, the procedure for eliminating the fast variable enables us to write down a formal expansion of the torus in a series in ε . All the coefficients in this expansion are analytic functions of the phase variables. If the torus is analytic in ε in a neighbourhood of zero, then this formal expansion must coincide with the true one (as an asymptotic expansion of an analytic function), converge, and therefore represent an analytic function of the phase variables. Thus, in the case under consideration the torus is not analytic in ε . \triangleright

The lack of analyticity of the torus in ε can be illustrated by very simple examples, in which the torus is nevertheless analytic in the phase variables.

Example 6.6 ([116]). Let $\rho, \vartheta \bmod 2\pi$ be polar coordinates on the plane of slow variables. In the annulus $1/2 < \rho < 2$ consider the equations of perturbed motion

$$\dot{\rho} = -\varepsilon[\rho - 1 + P(\vartheta, \varphi)], \quad \dot{\vartheta} = \varepsilon, \quad \dot{\varphi} = 1,$$

where

$$P = \sum_k a_k \exp(i(k_1\vartheta + k_2\varphi)), \quad a_k = \exp(-|k|), \quad k_2 \neq 0.$$

Averaging over φ we obtain

$$\dot{\rho} = -\varepsilon(\rho - 1), \quad \dot{\vartheta} = \varepsilon.$$

The circle $\rho = 1$ is a limit cycle of the averaged system. It is easy to find the invariant torus of the exact system

$$\rho = 1 - \varepsilon \sum_k \frac{a_k \exp(i(k_1\vartheta + k_2\varphi))}{i(k_1\varepsilon + k_2) + \varepsilon}, \quad k_2 \neq 0.$$

In an arbitrarily small complex disc $|\varepsilon| < \varepsilon_0$ there exists a value of ε for which one of the denominators in this formula vanishes. Consequently, the invariant torus is not analytic in ε . \triangle

If the averaged system has a degenerate equilibrium position (a cycle), then the question of the existence and orbital stability of the corresponding periodic solution (torus) of the exact system can, as a rule⁹, be answered by using the higher approximations of the procedure for eliminating the fast variables.

If the averaged system has an l -dimensional invariant torus, $l \geq 2$, then the existence of an $(l + 1)$ -dimensional invariant torus of the exact system close to it with respect to the slow variables was established under certain conditions in [270].

⁹ For a non-conservative perturbation.

One of the applications of averaging in single-frequency systems is the study of the behaviour of the phase point under repeated application of a near-identity map. This is a map of the form

$$I \mapsto I + \varepsilon l(I, \varepsilon). \quad (6.13)$$

Every such map with a smooth function l can be represented as the shift map by time 2π along the solutions of a single-frequency system of the standard form (6.2), in which time plays the role of the fast phase:

$$\dot{I} = \varepsilon f(I, t, \varepsilon). \quad (6.14)$$

It is usually sufficient to assume that the right-hand side of (6.14) is a continuous function of time, although it can also be chosen to be smooth, and if the function l is analytic, then analytic [214, 361, 362, 514, 592].

If the right-hand side of equation (6.14) is continuous in time t and infinitely differentiable in I , then the procedure for eliminating the fast angle variable of § 6.1.2 enables one, for any prescribed $r > 1$, to defer the dependence on time to the terms $O(\varepsilon^{r+1})$ using a change of variables. Hence the map (6.13) can be represented in the form

$$I \mapsto I + \varepsilon L(I, \varepsilon) + \varepsilon \alpha(I, \varepsilon), \quad \alpha = O(\varepsilon^r), \quad (6.15)$$

so that the truncated map, without the term $\varepsilon \alpha$, is the shift map by time 2π along the trajectories of the autonomous system

$$\dot{J} = \varepsilon F_{\Sigma}(J, \varepsilon), \quad F_{\Sigma}(J, \varepsilon) = \frac{1}{2\pi} l(J, 0) + O(\varepsilon). \quad (6.16)$$

Now suppose that the function l in (6.13) can be analytically continued to the complex δ -neighbourhood of the domain of definition of the system remaining bounded above in absolute value by the constant C .

Theorem 6.5 ([455]). *The map (6.13) can be represented in the form (6.15) with an exponentially small remainder α satisfying $|\alpha| < c_1 \exp(-c_2^{-1}/\varepsilon)$ so that the truncated map is the shift map by time 2π along the trajectories of the autonomous system (6.16).*

This theorem is an immediate consequence of Theorem 6.2 and the observation [455] that for systems of the form (6.14) Theorem 6.2 is also valid if the right-hand side is a continuous function of time.

By Theorem 6.5 an analytic near-identity map can be included with an exponential accuracy into the phase flow of an autonomous system of equations. The remaining exponentially small error is unavoidable in the general case (but it can be eliminated in a domain where the vector field $l(J, 0)$ can be rectified; cf. Theorem 6.3 and [291]).

Near-identity maps of the form (6.13) arise, in particular, in numerical integration of autonomous systems of ordinary differential equations using

step-by-step methods (for example, the Euler or Runge–Kutta methods). In this case the role of the small parameter ε is played by the step of the method. The map (6.13) describes the behaviour of the phase point when it advances by one step along the approximate trajectory. Since a map cannot, generally speaking, be included exactly into the flow of an autonomous system, a numerical method usually does not integrate accurately any autonomous system of equations on large time intervals. However, there is an autonomous system of equations which is integrated by such a method with a fairly high accuracy (in the analytic case, with an accuracy exponential in $1/\varepsilon$). The right-hand side of this new system is close to the right-hand side of the original system (to which the integration method is applied) already with a polynomial accuracy (the degree of the corresponding polynomial is called the order of the numerical method).

6.1.5 Averaging in Systems with Constant Frequencies

Systems with constant frequencies, that is, with frequencies independent of the slow variables, arise when we consider a small nonlinear interaction of linear oscillatory systems¹⁰, or the influence of quasi-periodic perturbations on linear oscillatory systems, or the action of fast external quasi-periodic forces on a nonlinear non-oscillatory system (for example, the effect of vibrations of two asynchronous engines on the motion of a ship or a plane).

We consider an analytic system of the standard form (6.2) with constant frequencies. We assume that the components of the frequency vector ω are strongly incommensurable:

$$|(k, \omega)| > c^{-1}|k|^{-\nu}, \quad c, \nu = \text{const} > 0, \quad (6.17)$$

for all integer vectors $k \neq 0$. It is well known [36] that for $\nu > m - 1$ the set of points ω for which condition (6.17) does not hold for any c has measure 0. Vectors ω satisfying condition (6.17) for some c and ν are also called *Diophantine* vectors.

Theorem 6.6. *If the frequencies of the unperturbed motion are constant and strongly incommensurable, then the difference between the slow motion $I(t)$ in the exact system and $J(t)$ in the averaged system remains small over time $1/\varepsilon$:*

$$|I(t) - J(t)| < c_1\varepsilon \quad \text{if} \quad I(0) = J(0), \quad 0 \leq t \leq 1/\varepsilon.$$

◁ The first-approximation change of variables of the procedure of § 6.1.2 is constructed by the formula

$$I = J + \varepsilon u(J, \psi), \quad u = \sum_{k \neq 0} \frac{f_k \exp(i(k, \psi))}{i(k, \omega)}. \quad (6.18)$$

¹⁰ Indeed, in a linear system the frequency is independent of the amplitude.

The Fourier coefficients f_k of the analytic function f are exponentially decreasing as the order of the harmonic increases: $|f_k| < c_2 \exp(-c_3^{-1}|k|)$. Because of the strong incommensurability of the frequencies, the denominators in (6.18) are decreasing only like a power. Hence the series in (6.18) converges and defines a near-identity change of variables. The rest of the proof is exactly the same as for Theorem 6.1. \triangleright

Remark 6.5. It is clear from the proof that the theorem remains valid if the perturbation has finite but sufficiently high smoothness in the phase; then the Fourier coefficients of the perturbation are decreasing like a power with a sufficiently high exponent. It is easy to verify that the existence of $\nu + m + 2$ derivatives is enough.

Remark 6.6. It is also clear from the proof that the result remains valid if the condition of strong incommensurability (6.17) is satisfied only for the vectors k involved in the Fourier expansion of the perturbation f .

If, instead of (6.17), we have the weaker incommensurability condition $(k, \omega) \neq 0$ for $k \in \mathbb{Z}^m \setminus \{0\}$, then averaging can still be applied for describing the motion. However, the accuracy may be worse than ε (for example, $\sqrt{\varepsilon}$ or $1/|\ln \varepsilon|$). Namely, the following assertion holds.

Theorem 6.7 ([16]). *For any $\eta > 0$ there exists $\varepsilon_0 = \varepsilon_0(\eta)$ such that for $0 < \varepsilon < \varepsilon_0$ we have*

$$|I(t) - J(t)| < \eta \quad \text{if} \quad I(0) = J(0), \quad 0 \leq t \leq \frac{1}{\varepsilon}.$$

(Here we assume that the quantity $I(0)$ is chosen in a given compact set; this is why ε_0 can be chosen to be independent of $I(0)$.)

If a system with constant frequencies is analytic and the frequencies are strongly incommensurable (that is, (6.17) holds), then, similarly to the single-frequency case, there is a change of variables deferring the dependence on the fast phases to exponentially small terms of the equations of order $O(\exp(-\text{const}/\varepsilon^a))$, $a = \nu + 1$; see [515, 550].

For systems with constant incommensurable frequencies there are numerous results on the existence of integral manifolds [427]. In particular, suppose that the frequencies are strongly incommensurable, the averaged system has an equilibrium or a periodic solution, and in the case of an equilibrium the real parts of the characteristic exponents of the averaged system linearized about it are non-zero, or in the case of a periodic solution the multipliers of the averaged system linearized about it do not lie on the unit circle.¹¹ Then the exact system has an invariant torus that is close, respectively, to the equilibrium or the periodic solution with respect to the slow variables (this torus is

¹¹ Except for one of them equal to 1.

m - or $(m+1)$ -dimensional, respectively) [360, 269, 270].¹² Even in an analytic system this torus is as a rule not analytic either in ε or in the phase variables (see Proposition 6.1 and Example 6.5), but the procedure for eliminating the fast variables enables one to construct for it an asymptotic expansion with respect to ε .

If the averaged system has an l -dimensional invariant torus, $l \geq 2$, then the existence of an $(l+m)$ -dimensional invariant torus of the exact system close to it with respect to the slow variables was established under certain conditions in [270].

In the analysis of motion on the torus generated by an equilibrium of the averaged system one has to distinguish the cases where, in equations (6.2) of the perturbed motion, $g = 0$ (that is, the perturbation is quasi-periodic in time) or $g \neq 0$. If $g = 0$, then the motion on the torus is conditionally periodic with frequency vector ω ; see [116]. If $g \neq 0$, then the nature of the motion can be different. For example, for a two-dimensional torus the motion is characterized by the Poincaré rotation number similarly to the description in §6.1.4; see [360]. If the unperturbed frequencies are regarded as parameters of the problem, then in an analytic system for any ε and any vector $\omega_* \in \mathbb{R}^m$ with strongly incommensurable components there exist unperturbed frequencies $\omega = \omega_* + \varepsilon \Delta(\varepsilon, \omega_*)$ such that the motion on the torus under consideration is conditionally periodic with frequency vector ω_* ; see [116]. Here $\Delta(\varepsilon, \omega_*)$ is an analytic function of ε . The reason is that for a suitable choice of the amendment Δ there exists an analytic near-identity change of variables $(I, \varphi) \mapsto (J, \psi)$ which is 2π -periodic in the phases and reduces the equation for the phase to the form $\dot{\psi} = \omega_*$. This implies the assertion on the motion on the torus stated above.

Systems with constant frequencies is an important special case of *systems in Bogolyubov's standard form*:

$$\dot{x} = \varepsilon A(t, x, \varepsilon), \quad x \in \mathbb{R}^p,$$

where the function A is assumed to satisfy the *uniform mean condition*: the limit

$$\lim_{T \rightarrow \infty} \frac{1}{T} \int_0^T A(t, x, 0) dt = A_0(x)$$

exists uniformly in x . Indeed, introducing in a system with constant frequencies the deviation $\xi = \varphi - \omega t$ from the uniform rotation and setting $x = (I, \xi)$ we arrive at equations in the standard form. Here the uniform mean condition

¹² In [360] this assertion was proved for the case where there are two fast and two slow variables and the averaged system has a stable equilibrium, and in [270] for any number of variables for the case of a stable equilibrium or a stable periodic solution of the averaged system. The assertion for the general case of hyperbolic equilibrium or periodic solution follows from the results of [269].

is satisfied, since $A(t, x, \varepsilon)$ is a quasi-periodic function of time t .

Bogolyubov's averaging principle [15] consists in replacing the original system in the standard form by the averaged system

$$\dot{y} = \varepsilon A_0(y).$$

Many of the results on averaging in systems with constant frequencies (including Theorem 6.7 and the theorems on the birth of conditionally periodic motions from equilibria and periodic motions of the averaged system) can be generalized to systems in the standard form [15].

6.1.6 Averaging in Non-Resonant Domains

We consider a perturbed multi-frequency system (6.2) in which the frequencies depend on the slow variables: $\omega = \omega(I)$, $I \in B$. We say that the domain B is *non-resonant* in the first approximation of perturbation theory (or simply non-resonant) if for all $I \in B$ the condition of strong incommensurability

$$|(k, \omega(I))| > c^{-1}|k|^{-\nu} \quad (6.19)$$

holds for some constants c, ν and all the integer vectors $k \neq 0$ such that the harmonic with the phase (k, φ) is involved in the Fourier expansion of the perturbation f on the right-hand side of system (6.2).

If the domain B is non-resonant, then, similarly to Theorem 6.6, averaging can be applied and guarantees an accuracy of order ε on times of order $1/\varepsilon$. If condition (6.19) is replaced by the weaker incommensurability condition $(k, \omega(I)) \neq 0$, then, similarly to Theorem 6.7, averaging can also be applied, but the accuracy may worsen.

In a multi-frequency generic system there are no non-resonant domains, since the incommensurability condition (for the vectors k specified above) fails, generally speaking, on an everywhere dense set of points. However, sometimes in applications there arise problems in which such domains nevertheless exist. For example, non-resonant domains exist if the perturbation contains only finitely many harmonics and the frequencies are independent.

6.1.7 Effect of a Single Resonance

The main peculiarities of multi-frequency systems are related to resonances. According to the averaging principle, for describing the perturbed motion near one chosen resonance and far from the other resonances one should partially average the equations of motion taking into account the chosen resonance. In many cases this approximation can be justified by using the procedure of § 6.1.3. In this subsection we consider the resulting partially averaged system. It has the usual form of a perturbed system, but the perturbation depends on the phases only via one linear combination of them with integer

coefficients:

$$\begin{aligned} \dot{I} &= \varepsilon f(I, \gamma), & \gamma &= (k, \varphi), \\ \dot{\varphi} &= \omega(I) + \varepsilon g(I, \gamma). \end{aligned} \tag{6.20}$$

Here only one resonance is possible: $(k, \omega) = 0$. The main effects connected with the influence of a single resonance appear already in system (6.20), the study of which is therefore of considerable interest.

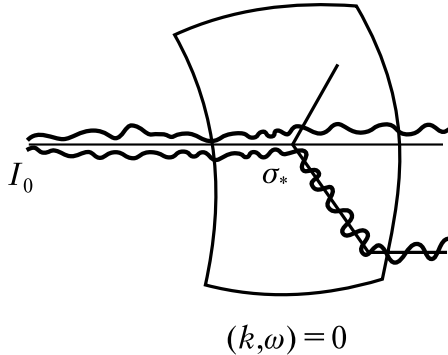

Fig. 6.5.

Suppose that a solution of the system obtained from (6.20) by averaging over γ intersects transversally the *resonant surface* (Fig. 6.5):

$$\left(k, \frac{\partial \omega}{\partial I} \langle f \rangle^\gamma \right) \neq 0 \quad \text{for } (k, \omega) = 0.$$

The solution of the exact system (6.20) may behave quite differently. For certain relations between the phases *capture into resonance* is possible: reaching a neighbourhood of the resonant surface the point starts moving so as to approximately preserve the commensurability thus arisen (Fig. 6.5); see [260, 429]. The averaging over γ is inapplicable for describing such a motion: over time $1/\varepsilon$ the solutions of the exact and averaged systems deviate by a quantity of order 1. However, capture into resonance and such a large error of averaging are possible only for an exceptional set of initial conditions, whose measure is estimated from above by a quantity of order $\sqrt{\varepsilon}$. For the other initial conditions the averaging describes the motion with an accuracy at least of order $\sqrt{\varepsilon} |\ln \varepsilon|$ (under certain fairly general assumptions).

Furthermore, it turns out that if a capture into resonance does occur, then the set of captured points tends to spread in the phase space everywhere densely as $\varepsilon \rightarrow 0$: a ball of diameter of order ε contains both captured and non-captured points. If, as it happens in practical problems, the initial conditions are known up to an error greater than ε , then one cannot say definitely

whether a point will be captured into resonance or not. The problem becomes probabilistic in nature. One can assert that the probability of capture into resonance is small and tends to zero like $\sqrt{\varepsilon}$ as $\varepsilon \rightarrow 0$.

Another phenomenon related to the effect of a single resonance is *scattering on resonance* [73, 188]. Consider the motion of a phase point crossing the resonant surface without capture. Before crossing the resonant surface, far from it, the behaviour of the slow variables is described to within $O(\varepsilon)$ by some solution of the averaged system. This follows from the fact that in the variables I, γ the system becomes a single-frequency one, with non-zero frequency far from the resonance. On crossing the resonant surface, sufficiently far from it, the behaviour of the slow variables is again described to within $O(\varepsilon)$ by some solution of the averaged system, but now it is another solution, different from the one before the crossing. The difference between the solutions of the averaged system describing the motion before and after the crossing is a quantity of order $\sqrt{\varepsilon}$ for most of the initial conditions. Thus, one can consider that the result of crossing the resonance without capture is a jump from one solution of the averaged system onto another. This jump is sensitive to a change in the initial conditions: for a shift of the initial values of the slow variables by a quantity $\delta > \varepsilon$, the relative change of the magnitude of the jump is of order 1. Therefore here, too, the problem becomes probabilistic in nature: we should treat the jump as random scattering on the resonance and describe its probabilistic properties.

We consider the phenomena described above by an example. First we observe that in the variables I, γ , to the resonance there corresponds the vanishing of the frequency, and to crossing the resonance, a change of the direction of rotation of γ .

Example 6.7. Let the perturbed motion be described by the system of equations

$$\dot{I} = \varepsilon \left(1 + a \sin \gamma - \frac{1}{4} I \right), \quad \dot{\gamma} = I, \quad a = \text{const} > 0, \quad (6.21)$$

in the domain $|I| < 2$. The corresponding averaged equation has the form

$$j = \varepsilon \left(1 - \frac{1}{4} J \right).$$

Differentiating the equation for γ with respect to time we obtain

$$\ddot{\gamma} = \varepsilon (1 + a \sin \gamma - 1/4 \dot{\gamma}).$$

Introducing the slow time $\theta = \sqrt{\varepsilon} t$ and denoting the derivative with respect to θ by prime we arrive at the equation

$$\gamma'' = 1 + a \sin \gamma - \frac{1}{4} \sqrt{\varepsilon} \gamma', \quad (6.22)$$

which describes the motion of a pendulum with a constant torque and small friction. The phase portraits of the pendulum without friction for $a < 1$ and

$a > 1$ are depicted in Fig. 6.6. In the case $a < 1$ the phase portrait of the problem with small friction is the same as without friction. The pendulum passes from reverse rotation into direct one. The time τ of the motion from the straight line $\gamma' = -1$ to the straight line $\gamma' = +1$ along various phase curves may differ by a quantity of order 1. Returning to the original time and the original variable I we obtain the following picture. Every point passes through the resonance $I = 0$, that is, capture is impossible here. The time of traversing the $\sqrt{\varepsilon}$ -neighbourhood of the resonance may differ for various trajectories by a quantity of order $1/\sqrt{\varepsilon}$. Correspondingly, during the traverse of this neighbourhood an averaging error of order $\sqrt{\varepsilon}$ is accumulated, which causes scattering on the resonance.

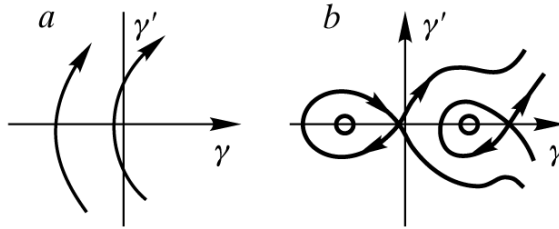

Fig. 6.6.

For the case $a > 1$ the phase portrait of the problem with friction is depicted in Fig. 6.7. Along the *separatrix* a strip of width of order $\sqrt{\varepsilon}$ is formed of the phase points for which the pendulum passes from rotation into oscillations. To a passage into oscillations there corresponds a capture into resonance in the original variables. In the unshaded area in Fig. 6.7 the pendulum passes from reverse rotation into direct one. For a trajectory passing at a distance $\xi > \varepsilon$ from a saddle singular point this passage takes a time of order $|\ln \xi|$. Returning to the original variables we see that a part of order $\sqrt{\varepsilon}$ of the set of all phase points turns out to be captured into resonance. We form the exceptional set of measure of order $\sqrt{\varepsilon}$ consisting of the points that either are captured into resonance, or are in the resonance at the initial instant, or

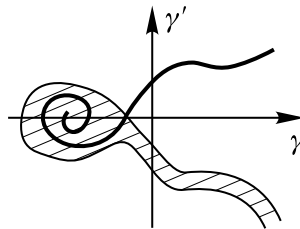

Fig. 6.7.

pass closer than ε from the saddles. The points that do not belong to this set cross the $\sqrt{\varepsilon}$ -neighbourhood of the resonance in a time t of order from $1/\sqrt{\varepsilon}$ to $|\ln \varepsilon|/\sqrt{\varepsilon}$. During the crossing an averaging error is accumulated of order from $\sqrt{\varepsilon}$ to $\sqrt{\varepsilon}|\ln \varepsilon|$, which is responsible for scattering on the resonance.

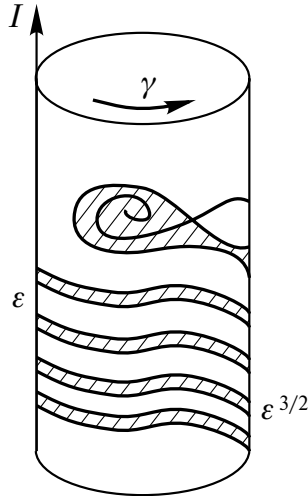

Fig. 6.8.

The portrait of the problem in the original variables I, γ on the phase cylinder is shown in Fig. 6.8. At a distance of order 1 from the resonance the coils of the separatrix are at distances of order ε from one another. Adjacent to the separatrix there is the shaded strip of width of order $\varepsilon^{3/2}$ consisting of captured points. Thus, the points that will finally be captured indeed tend to fill everywhere densely some domain of the phase space as $\varepsilon \rightarrow 0$. \triangle

The main phenomena connected with a single resonance take place in the $c\sqrt{\varepsilon}$ -neighbourhood of the resonant surface, $c = \text{const}$. In such a neighbourhood, system (6.20) can be reduced to the “pendulum” form that resembles equation (6.22). This reduction was used in a number of papers [188, 309, 420, 429, 433, 444, 448]. We now describe it. We denote a point on the resonant surface by $\sigma = (\sigma_1, \dots, \sigma_{n-1})$. We characterize a point I in a neighbourhood of the resonant surface by the coordinates ρ, σ , where $\rho = (k, \omega(I))$ and σ is the projection of I onto the resonant surface. We introduce the slow time $\theta = \sqrt{\varepsilon}t$ and the normalized distance to the resonant surface $r = \rho/\sqrt{\varepsilon}$. We denote by prime the differentiation with respect to θ . We obtain

$$\begin{aligned} \gamma' &= r + \sqrt{\varepsilon}\alpha_1(\gamma, \sigma, \sqrt{\varepsilon}r), \\ r' &= P(\gamma, \sigma) + \sqrt{\varepsilon}r\alpha_2(\gamma, \sigma, \sqrt{\varepsilon}r), \\ \sigma' &= \sqrt{\varepsilon}\alpha_3(\gamma, \sigma, \sqrt{\varepsilon}r). \end{aligned} \tag{6.23}$$

The functions P , α_i have period 2π in γ . If we set $\varepsilon = 0$ in (6.23), then we obtain a Hamiltonian¹³ system describing the dynamics of a pendulum in a conservative field in the presence of a constant torque:

$$\gamma' = r, \quad r' = P(\gamma, \sigma), \quad \sigma = \text{const}, \quad \langle P \rangle^\gamma = \left(k, \frac{\partial \omega}{\partial I} \langle f \rangle^\gamma \right) \neq 0. \quad (6.24)$$

This system is of course integrable. The motion in a neighbourhood of the resonance is described by a small perturbation of this system according to (6.23).

Above we considered the application of averaging for describing the motion of points passing through a resonance without capture. We now show how averaging can be used for describing the motion of points captured into resonance. We use the equations of motion in the form (6.23). Suppose that the corresponding “intermediate” unperturbed system (6.24) (pendulum) satisfies the following two conditions of generality of position: on its phase portrait the unstable singular points are non-degenerate for all σ (condition B), and the separatrices do not connect different singular points (condition B'). Then this phase portrait is similar either to Fig. 6.6*b* (but there may be more oscillatory domains¹⁴), or to Fig. 6.6*a*. We shall not consider the last case now,¹⁵ since it corresponds to the absence of capture. As σ varies, the oscillatory domains do not vanish, do not appear, and do not merge with each other. We choose one of these domains and introduce in it the action–angle variables λ , χ of the unperturbed pendulum. The variation of the quantities σ , λ , χ in the perturbed motion is described by an ordinary single-frequency system where the role of the phase is played by χ , of time by θ , and of the small parameter by $\sqrt{\varepsilon}$. Averaging this system over χ we obtain equations, which approximately describe the variation of σ , λ on times θ of order $1/\sqrt{\varepsilon}$ (that is, on times t of order $1/\varepsilon$).¹⁶ The variation of σ characterizes a drift along the resonant surface, and the variation of λ the amplitude of oscillations about this surface. We say that initial conditions σ_0 , λ_0 for a solution of the system averaged in the oscillatory domain are taken on the separatrix if $2\pi\lambda_0$ is equal¹⁷ to the area of the oscillatory domain for $\sigma = \sigma_0$. The solutions with such initial conditions describe the motion from the instant of capture into resonance. The solutions terminating on the separatrix are defined in similar fashion; they describe the motion before exiting the resonance.

¹³ This should come as a surprise! The fact that the system obtained is Hamiltonian is discovered as a result of calculations and is by no means obvious beforehand.

¹⁴ Inside oscillatory domains of the system there may exist unstable singular points. To simplify the exposition we shall not consider this case.

¹⁵ But this case is nevertheless very important, since it is this case that is obtained after averaging for most of the resonances (see § 6.1.8).

¹⁶ These equations can have a non-degenerate equilibrium with $\lambda \neq 0$, to which by Theorem 6.4 there corresponds a limit cycle of the original system lying inside a loop of the separatrix.

¹⁷ Recall that $2\pi\lambda$ is the area bounded by a closed trajectory of the unperturbed pendulum.

The whole trajectory of a point in the presence of capture into resonance is approximately described as a curve glued together from several smooth pieces (Fig. 6.5). The first piece is a trajectory of the system averaged in the usual fashion outside the resonance before reaching the resonant surface; we denote the point of reaching the surface by σ_* . The second piece is a curve on the resonant surface determined by the oscillatory domain of the unperturbed pendulum into which the capture occurred. This curve is the σ -component of the solution of the system averaged in the required oscillatory domain with an initial condition on the separatrix for $\sigma = \sigma_*$. If at some instant this solution reaches the separatrix (let $\sigma = \sigma_{**}$ be the corresponding point), then there is a third piece – the solution of the usually averaged system starting at the point σ_{**} . From the point σ_* (where the first piece reaches the resonant surface) several curves can go out corresponding to captures into different oscillatory domains (Fig. 6.5). One can show that under fairly general assumptions the gluing of one of these curves to the first (non-resonant) piece describes the motion to within $O(\sqrt{\varepsilon} \ln \varepsilon)$ for most of the initial conditions. The exception is a set whose measure tends to zero faster than any power of ε as $\varepsilon \rightarrow 0$. This set consists of the points passing too close to the saddles of the unperturbed pendulum.

On the resonant surface, at some points there occurs capture into a given oscillatory domain, and at some points escape from it. These two types of points can be recognized as follows. Let $E = E(r, \gamma, \sigma)$ be the Hamiltonian of the pendulum (6.24) normalized so that it vanishes at the saddle singular point C and on the separatrix l which together form the boundary of the oscillatory domain under consideration. Then $E < 0$ in the oscillatory domain. We set

$$\Theta(\sigma) = - \oint_l \left(\frac{\partial E}{\partial \gamma} \alpha_1^0 + \frac{\partial E}{\partial r} r \alpha_2^0 + \frac{\partial E}{\partial \sigma} \alpha_3^0 \right) d\theta,$$

$$\alpha_i^0 = \alpha_i(\gamma, \sigma, 0), \quad i = 1, 2, 3,$$

where the integral with respect to time is taken along the solution of the pendulum equation (6.24) whose trajectory is the separatrix. The quantity $-\sqrt{\varepsilon}\Theta$ is the change of the energy of the pendulum in the principal approximation under the influence of the perturbation in (6.23) over one coil of the motion near the separatrix in the oscillatory domain. If $\Theta(\sigma) > 0$ at a point σ of the resonant surface, then near this point there occurs capture into the chosen oscillatory domain, and if $\Theta(\sigma) < 0$, then escape from this domain.

There are formulae for the probability of capture into resonance and for the amplitude of scattering on resonance [462]. In particular, the probability $Q(M_0)$ of the capture of a given initial point $M_0 = (I_0, \varphi_0)$ into a given oscillatory domain is given by the formula

$$Q(M_0) = \frac{\sqrt{\varepsilon}\Theta(\sigma)}{2\pi|(P)\gamma|} \Big|_{\sigma=\sigma_*},$$

where σ_* is the point where the trajectory of the averaged system passing through the initial point I_0 reaches the resonant surface, and it is assumed that $\Theta(\sigma_*) > 0$ (otherwise the probability of capture is equal to 0). Of course, we must define what is called the probability of capture in the deterministic system under consideration. Let U^δ be the ball of radius δ with centre at the point M_0 , and $U^{\delta,\varepsilon}$ the subset of U^δ consisting of the captured points. Then by definition (cf. [7]),

$$Q(M_0) = \sqrt{\varepsilon} \lim_{\delta \rightarrow 0} \lim_{\varepsilon \rightarrow 0} \frac{\text{meas } U^{\delta,\varepsilon} / \sqrt{\varepsilon}}{\text{meas } U^\delta},$$

where meas is the phase volume in the space of I, φ . Thus, the probability of capture is the leading term of the asymptotics for the relative measure of the captured points in the ball of small radius δ , where $1 \gg \delta \gg \varepsilon$.

Multiple passages through a resonance in non-conservative systems have not in the least been studied. Apparently they can give rise to quite unusual phenomena. For example, suppose that the system has two slow variables, and all the points of the phase plane of the averaged system “fall down” onto an asymptotically stable limit cycle. Suppose that this cycle intersects transversally the resonant surface (here a curve) and capture occurs at the intersection point; at some distance from the cycle the captured points are ejected from the resonance. Such an example can be easily constructed. Presumably (this is a conjecture!) a typical trajectory of such a system spends most of the time near the limit cycle of the averaged system, but in quasi-random time intervals is ejected from it to a distance of order 1. The mean length of these time intervals is of order $1/\varepsilon^{3/2}$. In similar fashion one can construct an example where the averaged system has two asymptotically stable limit cycles surrounding the origin, and along the two branches of the resonant curve points pass from the larger cycle into the domain inside the smaller one, and conversely (Fig. 6.9); see [460]. Then in the perturbed system (this is also a conjecture!) one will observe quasi-random walks between the limit cycles of the averaged system.

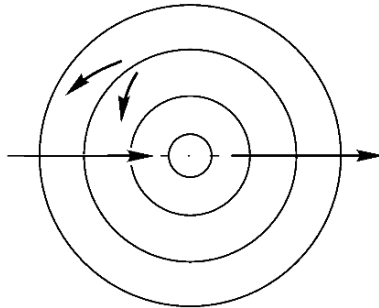

Fig. 6.9.

6.1.8 Averaging in Two-Frequency Systems

Consider a *two-frequency perturbed system* with frequencies $\omega_1(I), \omega_2(I)$:

$$\begin{aligned} \dot{I} &= \varepsilon f(I, \varphi, \varepsilon), \\ \dot{\varphi}_1 &= \omega_1(I) + \varepsilon g_1(I, \varphi, \varepsilon), \\ \dot{\varphi}_2 &= \omega_2(I) + \varepsilon g_2(I, \varphi, \varepsilon). \end{aligned} \tag{6.25}$$

We assume that the right-hand sides are analytic functions. We say that the system satisfies condition *A* if the frequency ratio ω_1/ω_2 varies along the system's trajectories with non-zero rate:

$$\mathcal{L}(I, \varphi, \varepsilon) = \left(\omega_1 \frac{\partial \omega_2}{\partial I} - \omega_2 \frac{\partial \omega_1}{\partial I} \right) f > c_1^{-1} > 0.$$

We say that the system satisfies condition \bar{A} if the frequency ratio ω_1/ω_2 varies with non-zero rate along the trajectories of the corresponding averaged system:

$$L(I) = \langle \mathcal{L} \rangle^\varphi = \left(\omega_1 \frac{\partial \omega_2}{\partial I} - \omega_2 \frac{\partial \omega_1}{\partial I} \right) F > c_1^{-1} > 0, \quad F = \langle f \rangle^\varphi, \quad \varepsilon = 0.$$

Henceforth, c_i, C_i are positive constants.

Theorem 6.8 ([73]). *If condition A holds, then the difference between the slow motion $I(t)$ in the perturbed system and $J(t)$ in the averaged system remains small over time $1/\varepsilon$: there exists a constant c_2 such that*

$$|I(t) - J(t)| < c_2 \sqrt{\varepsilon} \quad \text{if} \quad I(0) = J(0), \quad 0 \leq t \leq 1/\varepsilon.$$

◁ We define a number $N = N(\varepsilon)$ by the following condition: in the perturbation (6.25) the total amplitude of the harmonics of order greater than N is at most ε^2 . For an analytic function the amplitude of harmonics is decreasing exponentially as the order increases. Hence, $N < C_1 |\ln \varepsilon|$. We say that a resonance $k_1\omega_1 + k_2\omega_2 = 0$ with k_1 and k_2 coprime integers is *essential* if its order $|k_1| + |k_2|$ is less than or equal to N . On the frequency plane, to resonances there correspond straight lines with rational slopes passing through the origin (Fig. 6.10). The straight lines corresponding to essential resonances are rather sparse: it is easy to calculate that the angle between adjacent lines is at least $C_2^{-1} |\ln \varepsilon|^{-2}$.

If a resonance is not essential, then it has practically no effect on the motion over time intervals of order $1/\varepsilon$. The influence of an essential resonance manifests itself in a narrow strip around the resonant straight line (Fig. 6.10); this strip is called a *resonant zone*. As in Example 6.7, the width of the resonant zone turns out to be of order $\sqrt{\varepsilon} a_k$, where a_k estimates from above the amplitudes of the resonant harmonics of the perturbation; the quantity a_k is decreasing exponentially as $|k|$ increases.

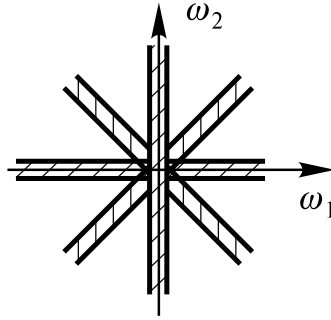

Fig. 6.10.

Condition *A* shows that the point successively crosses non-resonant and resonant zones in Fig. 6.10. In a non-resonant zone the change of variables of § 6.1.2 is defined, which reduces the exact system to the averaged one in the first approximation. The difference between the solutions of the exact and averaged systems accumulated in the non-resonant zones because of the discrepancy remaining under this reduction does not exceed $C_3\sqrt{\varepsilon}$. In the resonant zones the averaging is absolutely inadequate for describing the motion. But the total width of these zones is of order $\sqrt{\varepsilon}$. By condition *A*, the time that the solution spends in these zones is of order $1/\sqrt{\varepsilon}$. Over this time the solutions of the exact and averaged systems may diverge only by a quantity not exceeding $C_4\sqrt{\varepsilon}$. As a result, the total deviation accumulated in non-resonant and resonant zones is at most $c_2\sqrt{\varepsilon}$. \triangleright

The hypothesis of Theorem 6.8 can be weakened. We say that system (6.25) satisfies condition *A'* (see [311]) if condition \bar{A} holds and in addition at each resonance $k_1\omega_1 + k_2\omega_2 = 0$ the frequency ratio varies with non-zero rate along the trajectories of the system partially averaged taking into account this resonance (see § 6.1.1):

$$L(I) + \left(\omega_1 \frac{\partial \omega_2}{\partial I} - \omega_2 \frac{\partial \omega_1}{\partial I} \right) F_k(I, \gamma) > \frac{1}{2}c_1^{-1} > 0, \tag{6.26}$$

where $\gamma = k_1\varphi_1 + k_2\varphi_2$ and $F_k(I, \gamma)$ is the sum of the harmonics of the function f depending on the phase γ . The quantity $|F_k|$ is decreasing as $|k|$ increases. Hence there exists a number N_0 independent of ε such that for $|k| > N_0$ inequality (6.26) follows from condition \bar{A} . We say that the resonances with $|k| \leq N_0$ are *strong* and the other resonances are *weak*. It suffices to verify inequality (6.26) for the strong resonances.

Theorem 6.9. *If condition *A'* holds, then the conclusion of Theorem 6.8 holds.*

\triangleleft As in the proof of Theorem 6.8, we must consider separately the motion in non-resonant and resonant zones. In a non-resonant zone the averaged system

provides a good description of the motion. Condition \bar{A} shows that the point does not get stuck in this zone. As in Theorem 6.8, the total averaging error accumulated in the non-resonant zones is at most $C_5\sqrt{\varepsilon}$. In a resonant zone the change of variables of § 6.1.3 is defined, which reduces the system, in the first approximation, to the system partially averaged taking into account this resonance. Therefore condition A' implies that it is also impossible to get stuck in a resonant zone. The sojourn time of the point in one such zone is of order of the width of the zone divided by ε . The remaining estimates are as in the proof of Theorem 6.8. \triangleright

Condition \bar{A} stated at the beginning of this subsection does not obstruct capture into resonance. It turns out that under this condition the total effect of passing through the resonances is the same as the effect of a single resonance described in § 6.1.7.

Theorem 6.10 ([448]). *If the system satisfies condition \bar{A} and in addition a certain condition B (which almost always holds), then there exist constants c_2, c_3 such that for all initial points I_0, φ_0 , except for a set of measure not exceeding $c_2\sqrt{\varepsilon}$, the difference between the slow motion $I(t)$ in the exact system and the motion $J(t)$ in the averaged system remains small over time $1/\varepsilon$:*

$$|I(t) - J(t)| < c_3\sqrt{\varepsilon} |\ln \varepsilon| \quad \text{if} \quad I(0) = J(0), \quad 0 \leq t \leq \frac{1}{\varepsilon}.$$

For every $\varkappa \geq c_2\sqrt{\varepsilon}$ and for all initial points, except for a set of measure not exceeding \varkappa , we have

$$|I(t) - J(t)| < c_4\sqrt{\varepsilon} |\ln c_5^{-1}\varkappa| \quad \text{if} \quad I(0) = J(0), \quad 0 \leq t \leq \frac{1}{\varepsilon}.$$

\triangleleft In the non-resonant zones and in the resonant zones of weak resonances the analysis is the same as that described above. The averaging error accumulated in these zones does not exceed $C_6\sqrt{\varepsilon}$. It remains to consider the strong resonances, which, as we know, are few and far between. Condition B consists in that for each strong resonance the system partially averaged taking into account this resonance satisfies condition B of § 6.1.7 (the non-degeneracy of singular points of the corresponding “pendulum”; see § 6.1.7). In a neighbourhood of a strong resonance we perform the change of variables of § 6.1.3, which reduces the exact system, in the first approximation, to the corresponding partially averaged system. The resulting system differs from the system with a single resonance in § 6.1.7 only by a small perturbation. The picture of passing through the resonance is described in § 6.1.7. For all initial conditions, except for a set of measure of order $\sqrt{\varepsilon}$, the resonant zone is crossed in a time not exceeding $C_7|\ln \varepsilon|/\sqrt{\varepsilon}$. The averaging error accumulated over this time does not exceed $C_8\sqrt{\varepsilon} |\ln \varepsilon|$. Combining the estimates over all zones we obtain that the total error does not exceed $c_3\sqrt{\varepsilon} |\ln \varepsilon|$. For the initial conditions lying

outside some set of measure $\varkappa > C_9\sqrt{\varepsilon}$ the resonant zone is crossed in a time not exceeding $C_{10}|\ln C_{11}^{-1}\varkappa|/\sqrt{\varepsilon}$. Correspondingly, for such initial conditions the averaging error does not exceed $c_4\sqrt{\varepsilon}|\ln c_5^{-1}\varkappa|$. \triangleright

Example 6.8. Consider oscillations of a particle in a one-dimensional potential well in the presence of a small periodic perturbation and small friction:

$$\ddot{x} = -\frac{\partial U}{\partial x} + \varepsilon a S(t) - \varepsilon \dot{x},$$

where S is a 2π -periodic function of t , and the graph of $U(x)$ and the phase

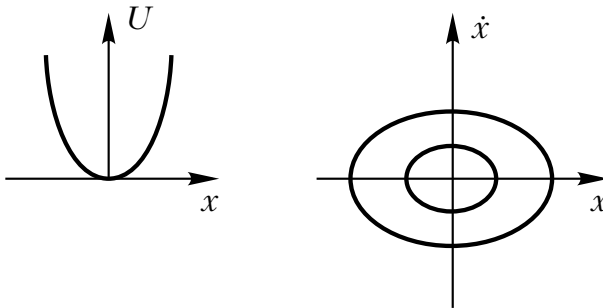

Fig. 6.11.

portrait of the unperturbed ($\varepsilon = 0$) system are depicted in Fig. 6.11. We assume that the unperturbed system is nonlinear, so that the period of motion is different for different trajectories. Let $h = 1/2 \dot{x}^2 + U(x)$ be the energy of the unperturbed motion, and φ the phase on the unperturbed trajectories. The perturbed system is a two-frequency one, φ and t are the fast variables, and h is the slow one. The equation for h has the form

$$\dot{h} = \varepsilon [a\dot{x}S(t) - \dot{x}^2].$$

Averaging over φ, t we obtain

$$\dot{h} = -\varepsilon \langle \dot{x}^2 \rangle.$$

The motion is considered in the domain $1 < h < 2$.¹⁸ The averaging leads to the conclusion that h decreases and all the points leave this domain. For sufficiently small a , condition A holds and the averaging describes the motion for all initial conditions. Condition \bar{A} holds for all a . It guarantees that the averaging is applicable for most of the initial data. But a proportion of order $\sqrt{\varepsilon}$ of points can be stuck at the resonances in the domain $1 < h < 2$. A detailed analysis of the motion in this problem for $U = x^2/2 + \mu x^4/4$ (Duffing's problem) is contained in [433]. \triangle

¹⁸ In fact, the results are valid in the entire domain $h \geq 0$; see [433].

Remark 6.7. There have been no studies of the case where condition \bar{A} fails for two-frequency systems, that is, where the frequency ratio of the fast motion varies non-monotonically in the averaged motion. For systems of the form (6.20) (that is, single-frequency systems in which the frequency can vanish) the following best-possible estimate holds in this case: there exist constants c_2, c_3 such that outside a set of measure $\varkappa > c_2\sqrt{\varepsilon}$ the averaging error is at most $c_3\sqrt{\varepsilon}/\sqrt{\varkappa}$ (under additional conditions of generality of position); see [97].

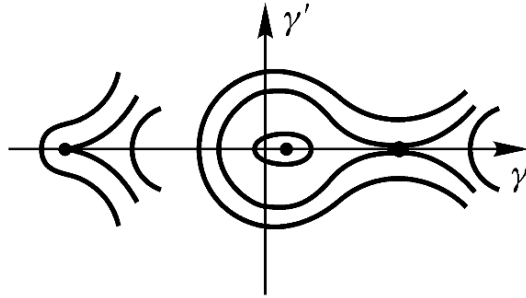

Fig. 6.12.

Remark 6.8. For the case where condition \bar{A} holds but condition B fails (so that the phase portrait of the “pendulum” corresponding to the resonance may have the form shown in Fig. 6.12) the following best-possible estimate holds: there exist constants c_2, c_3 such that outside a set of measure $\varkappa > c_2\sqrt{\varepsilon}$ the averaging error is at most $c_3\sqrt{\varepsilon}/\sqrt{\varkappa}$ (for analytic systems this estimate was obtained in [513], for systems of finite smoothness it can be obtained by combining the results of [97] and [448], and for the case of a single slow variable this estimate was obtained in [448]).

We give several examples of non-conservative two-frequency systems:

- a pendulum under the action of a non-conservative force periodically depending on time [178];
- two weakly coupled nonlinear oscillators in the presence of weak friction;
- fast rotation of a heavy rigid body in a resisting medium [61, 549];
- motion of a passively gravitating body (an asteroid) in the restricted three-body problem (see Ch. 2) in the presence of resistance of the medium or a weak propulsive force [100].

In these problems most of the solutions are described by independent averaging over the phases. However, capture into resonance is also possible for certain relations between the parameters.

6.1.9 Averaging in Multi-Frequency Systems

The case where the number of frequencies is greater than two has been studied much less than the two-frequency case. One of the features of the two-frequency systems is simple disposition of the resonant surfaces (Fig. 6.10). For a higher number of frequencies these surfaces are situated quite differently.

Example 6.9. Consider the unperturbed three-frequency system

$$\dot{\varphi}_1 = I_1, \quad \dot{\varphi}_2 = I_2, \quad \dot{\varphi}_3 = 1, \quad \dot{I}_s = 0 \quad (s = 1, 2).$$

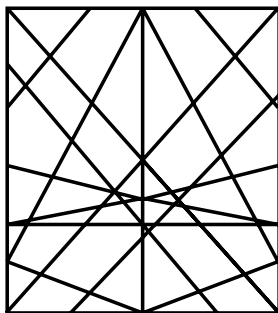

Fig. 6.13.

Here the resonant surfaces are all the straight lines with rational equations on the plane I_1, I_2 (Fig. 6.13). A curve on the plane I intersects many of the resonant straight lines

- a) at small angles (since arbitrarily close to any linear element there is a linear element of a resonant straight line) and
- b) near the points of mutual intersection of resonant straight lines, which are points of multiple resonance.

Therefore, whereas in the two-frequency case the main effect is passing through a single resonance, for a higher number of frequencies we must necessarily take into account tangency to resonances and the joint influence of several resonances (two in this example). \triangle

There have been no comprehensive studies taking into account the details of these phenomena for multi-frequency systems. Nevertheless some estimates are known that justify the applicability of the averaging method. They were obtained on the basis of the following general consideration: if the set of points close to the resonant surfaces has small measure, then for most of the initial data the phase curve spends little time in this set; hence it is natural to expect that for most of the initial data averaging correctly describes the motion.

General results in this direction are due to Anosov [66] and Kasuga [305]. Anosov’s theorem states that for any positive number ρ the measure

$$\text{meas} \{I_0, \varphi_0 : \max_{0 \leq t \leq 1/\varepsilon} |I(t) - J(t)| > \rho \text{ for } I(0) = J(0) = I_0\}$$

of the set of initial data (in a compact set in the phase space) for which the error of describing the exact motion by the averaged one is greater than ρ tends to 0 as $\varepsilon \rightarrow 0$. This theorem was proved for perturbed systems of a more general form than the standard form (6.2): the common levels of the integrals of the unperturbed problem are not assumed to be tori; it is required that for almost all constant values of these integrals the unperturbed motion on the common level is ergodic.

For systems of the standard form (6.2) the technique of [305] enables one to obtain the following estimate of the averaging error.

Theorem 6.11 ([451]). *Suppose that one of the following two non-degeneracy conditions holds: either the rank of the map $I \mapsto \omega(I)$ is equal to the number of frequencies, or the rank of the map $I \mapsto (\omega_1(I) : \omega_2(I) : \dots : \omega_m(I))$ is by one less than the number of frequencies. Then the mean error (over the initial conditions) of the averaging method does not exceed a quantity of order $\sqrt{\varepsilon}$:*

$$\int \max_{0 \leq t \leq 1/\varepsilon} |I(t) - J(t)| dI_0 d\varphi_0 < c_1 \sqrt{\varepsilon}. \tag{6.27}$$

Corollary 6.1. *Let $E(\varepsilon, \rho)$ denote the set of the initial data within a fixed compact set for which the error is at least ρ . Then*

$$\text{meas } E(\varepsilon, \rho) < c_1 \frac{\sqrt{\varepsilon}}{\rho}. \tag{6.28}$$

Equivalently: outside a set of measure \varkappa the averaging error satisfies the estimate

$$|I(t) - J(t)| < c_1 \frac{\sqrt{\varepsilon}}{\varkappa}.$$

This estimate is best-possible [451].¹⁹ However, it is plausible that it can be improved for the class of generic perturbations (cf. the estimate for two-frequency systems under conditions \bar{A}, B , where the error is at most $c_2 \sqrt{\varepsilon} |\ln \varkappa|$).

If $m \geq n + 2$, then Theorem 6.11 is inapplicable, but the estimates (6.27) and (6.28) hold for almost all members of a typical family of frequencies with sufficiently large number of parameters λ ; see [96]. Instead of the non-degeneracy of the frequencies required in Theorem 6.11, here the following inequality is used: $|(k, \omega)| + |\partial(k, \omega)/\partial I| > c^{-1} |k|^{-\nu}$ for $\nu > m - 1$ and all $k \in \mathbb{Z}^m \setminus \{0\}$. For almost all values of λ this inequality holds with some $c > 0$. For $m \geq n + 2$ there is also a sufficient condition for an individual system to satisfy the estimates (6.27), (6.28); see [212].

¹⁹ In the class of polynomial estimates.

Theorem 6.12 ([96]). *For generic systems with m fast and n slow variables the mean error (over the initial conditions) of the averaging method is estimated from above by a quantity of order $\varepsilon^{1/(k+1)}$ if $m \leq \binom{n+k}{k} - n$.*

Correspondingly, the right-hand side of the estimate (6.28) takes the form $c_1 \varepsilon^{1/(k+1)}/\rho$. Non-generic systems belong to some hypersurface in the space of all systems.

If the averaged system has an equilibrium such that at the equilibrium point the unperturbed frequencies are strongly incommensurable and the real parts of the eigenvalues of the linearized averaged system are non-zero, then the exact system has an m -dimensional invariant torus close to this equilibrium with respect to the slow variables; see [269]. This assertion is a consequence of the similar assertion for a system with constant frequencies (cf. § 6.1.5). Indeed, by expanding the right-hand sides of the exact system about the equilibrium position of the averaged system and performing one step of the procedure for eliminating the fast phases we can reduce the original system near the equilibrium position to a system with constant unperturbed frequencies [269].

If the averaged system has a periodic solution, then, generally speaking, to it there may not correspond an $(m + 1)$ -dimensional invariant torus of the exact system (in contrast to the case where the unperturbed frequencies are constant, cf. § 6.1.5); a relevant example is given in [460]. The reason is that during the motion along the periodic solution of the averaged system the unperturbed frequencies change and become resonant at some instants. Because of captures into resonance (see § 6.1.7) some solutions of the exact system move away far from the asymptotically stable periodic solution of the averaged system.

6.1.10 Averaging at Separatrix Crossing

The averaging principle in § 6.1.1 was described under the assumption that the equations of motion in the unperturbed integrable system can be written in the standard form (6.1), and the equations of the perturbed motion in the form (6.2). However, in many problems the foliation of the phase space of the unperturbed integrable system into invariant tori has singularities on some hypersurfaces – the separatrices. In a neighbourhood of a separatrix the equations of motion cannot be reduced to the form (6.1), (6.2). The separatrices divide the phase space into domains with different regimes of motion (for example, for a pendulum the separatrix divides the phase portrait into the domains of rotations in different directions and of oscillations). A small perturbation causes evolution, which can result in a phase point of the perturbed system crossing a separatrix of the unperturbed problem and the regime of motion changing. This gives rise to a quasi-random behaviour.

Example 6.10 ([7]). Consider a one-dimensional system with the potential energy $U(q)$ (Fig. 6.14) and small friction $\varepsilon f(p, q)$, $0 < \varepsilon \ll 1$. It is clear that as time passes almost every point falls into one of the potential wells, A or B . But into which of them?

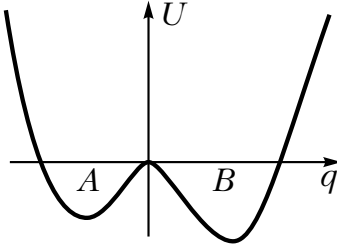

Fig. 6.14.

The phase portrait of the unperturbed ($\varepsilon = 0$) system is shown in Fig. 6.15. The separatrices l_1 and l_2 divide it into the domains G_1, G_2, G_3 . On the phase portrait of the perturbed system (Fig. 6.16) the initial conditions which lead to falling into different wells alternate. As $\varepsilon \rightarrow 0$ the deterministic approach to the problem no longer makes sense, since a small change in the initial conditions results in falling into the other well, while the initial conditions are always known only to within a certain accuracy. In [387] this phenomenon was called scattering on a saddle singular point.

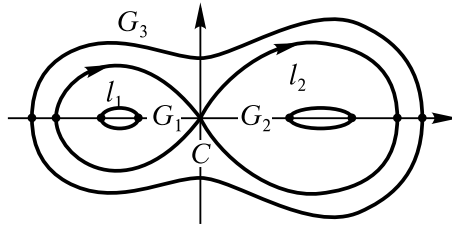

Fig. 6.15.

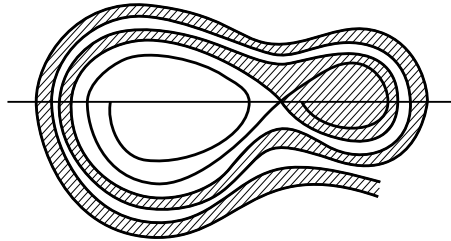

Fig. 6.16.

It is reasonable to regard falling into one or another well as a random event. The probability $P_1(x)$ of a point x of the phase plane falling into the well A is defined as the proportion of the points in a small neighbourhood of x falling into A as $\varepsilon \rightarrow 0$ (cf. § 6.1.7):

$$P_1(x) = \lim_{\delta \rightarrow 0} \lim_{\varepsilon \rightarrow 0} \frac{\text{meas } U_1^{\delta, \varepsilon}(x)}{\text{meas } U^\delta(x)}, \tag{6.29}$$

where $U^\delta(x)$ is the δ -neighbourhood of the point x and $U_1^{\delta, \varepsilon}(x)$ is the set of points of this neighbourhood falling into A . The probability P_2 is defined in similar fashion.

It turns out that if the initial energy is $h > 0$, then the probabilities of falling into A and B exist and can be calculated by the formulae

$$P_1 = \frac{\Theta_1}{\Theta_1 + \Theta_2}, \quad P_2 = 1 - P_1, \quad \Theta_\nu = - \int_{l_\nu} p f(p, q) dt, \quad \nu = 1, 2,$$

where the integrals are taken along the separatrices l_ν of the unperturbed system in the unperturbed motion. The probabilities are independent of the initial point x and are determined by the values of $f(p, q)$ on the critical energy level $h = 0$.

In this problem it is usually interesting to consider the variation of the energy h with time. Far from the separatrices of the unperturbed system this variation is approximately described by the averaging: the equations of the perturbed motion in the action-angle variables of the unperturbed system must be averaged over the angle; the energy h can be used instead of the action variable. The equations of the perturbed motion in these variables have a singularity on the separatrices. How to describe the separatrix crossing?

Fig. 6.17 depicts three solutions of the averaged system. The solution $h_3(\varepsilon t)$ starts at $t = 0$ in the domain $G_3 = \{h > 0\}$ with value equal to the energy of

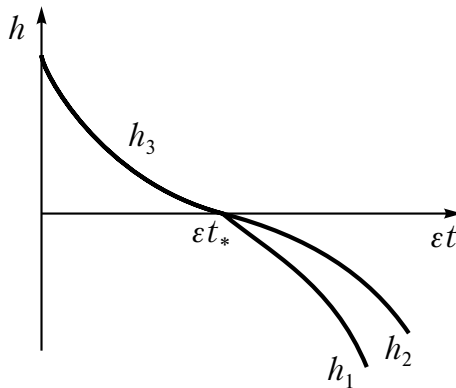

Fig. 6.17.

the initial point x and reaches the separatrix ($h = 0$) at some $t = t_*$. Glued to it there are the solutions $h_1(\varepsilon t)$ and $h_2(\varepsilon t)$ in the domains G_1 and G_2 , respectively, starting at $t = t_*$ on the separatrix: $h_{1,2}(\varepsilon t_*) = 0$. It turns out that the motion of most of the points falling into the well A (respectively, B) on times of order $1/\varepsilon$ are approximately described by gluing together the solutions h_3 and h_1 (respectively, h_3 and h_2). The exceptional set consists of the points passing too close to the saddle C and getting stuck near it for a long time; the measure of this set tends to zero as $\varepsilon \rightarrow 0$. One can say that with probability P_1 the motion is described by gluing together h_3 and h_1 , and with probability P_2 by gluing together h_3 and h_2 . \triangle

A similar loss of determinacy happens if friction is replaced by a slow variation of the potential that causes falling into one or another well (for example, if the point moves along a curve with two minima (see Fig. 6.14) in a slowly increasing gravitational field).

A fairly general situation in which such phenomena occur in single-frequency systems looks as follows [460] (the degree of generality of this situation is discussed at the end of this subsection, before Example 6.12). We have the system of equations

$$\dot{p} = -\frac{\partial H}{\partial q} + \varepsilon f_1, \quad \dot{q} = \frac{\partial H}{\partial p} + \varepsilon f_2, \quad \dot{\lambda} = \varepsilon f_3, \quad (6.30)$$

where $0 < \varepsilon \ll 1$, $(p, q) \in \mathbb{R}^2$, $\lambda \in \mathbb{R}^m$, $H = H(p, q, \lambda)$, and $f_i = f_i(p, q, \lambda, \varepsilon)$. The functions f_i are assumed to be infinitely differentiable. The unperturbed ($\varepsilon = 0$) system for p, q is a Hamiltonian one; its Hamiltonian function depends on the parameter λ . For definiteness we assume that the phase portrait of the unperturbed system for every λ has the same form as in Example 6.10, Fig. 6.15 (but other portraits can also be considered where there are non-degenerate saddle singular points connected by separatrices).

The separatrices l_1 and l_2 divide the unperturbed phase plane into three domains: G_1, G_2, G_3 (see Fig. 6.15). Under the influence of the perturbation, points from the domain G_i cross a separatrix and are captured into one of the domains G_j , $j \neq i$. Capture into one or another domain has to be regarded as a random event. The definition of the probabilities of these events for an initial point $x = (p, q, \lambda)$ is given by relation (6.29).

We assume the Hamiltonian H to be normalized, so that $H = 0$ at the saddle point (and therefore on the separatrices). Then $H > 0$ in G_3 and $H < 0$ in $G_{1,2}$.

In each of the domains the averaged system has the form

$$\dot{h} = \frac{\varepsilon}{T} \oint \left[\frac{\partial H}{\partial p} f_1^0 + \frac{\partial H}{\partial q} f_2^0 + \frac{\partial H}{\partial \lambda} f_3^0 \right] dt, \quad \dot{\lambda} = \frac{\varepsilon}{T} \oint f_3^0 dt, \quad (6.31)$$

where $T = \oint dt$ is the period of the unperturbed motion, $f_i^0 = f_i(p, q, \lambda, 0)$, $i = 1, 2, 3$, and the integrals are taken along the solution of the unperturbed system on which $H(p, q, \lambda) = h$.

For each of the domains we can extend by continuity the definition of the averaged system to the separatrix setting $\dot{h}|_{h=0} = 0$ and $\dot{\lambda}|_{h=0} = f_{3C}^0(\lambda)$, where f_{3C}^0 is the value of the function f_3^0 at the saddle point C . We can now regard the phase space of the averaged system as being obtained by gluing together, over the surface $h = 0$, the phase spaces of the averaged systems constructed separately for each of the domains G_i (Fig. 6.18).

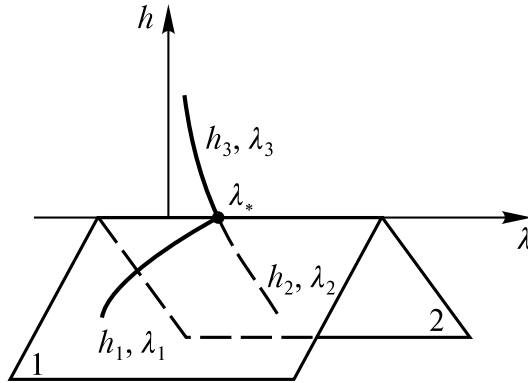

Fig. 6.18.

We introduce the quantities

$$\Theta_\nu(\lambda) = - \oint_{i_\nu} \left[\frac{\partial H}{\partial p} f_1^0 + \frac{\partial H}{\partial q} f_2^0 + \frac{\partial H}{\partial \lambda} f_3^0 \right] dt, \quad \nu = 1, 2, \tag{6.32}$$

$$\Theta_3(\lambda) = \Theta_1(\lambda) + \Theta_2(\lambda),$$

where the integrals are taken along the separatrices in the unperturbed motion. These integrals are improper (since the motion along a separatrix requires infinite time), but, as can be easily verified, they converge for the chosen normalization of the Hamiltonian. Below we assume the quantities Θ_ν to be positive. The value $-\varepsilon\Theta_\nu$ is close to the change of the energy on a segment of the perturbed trajectory close to the unperturbed separatrix. Therefore the positivity of Θ_ν guarantees that for most of the initial conditions the point approaches the separatrix sufficiently fast in the domain G_3 , and moves away from the separatrix sufficiently fast in the domains G_1 and G_2 .

We have the following assertions about the motion for $0 \leq t \leq 1/\varepsilon$ of the point with an initial condition (p_0, q_0, λ_0) , where $(p_0, q_0) \in G_3$ for $\lambda = \lambda_0$.

1°. Let $h_3(\varepsilon t)$, $\lambda_3(\varepsilon t)$ denote the solution of the averaged system in the domain G_3 with the initial condition $(H(p_0, q_0, \lambda_0), \lambda_0)$ (Fig. 6.18). Suppose that at some $\varepsilon t = \tau_*$ < 1 this solution reaches the separatrix: $h_3(\tau_*) = 0$. Then for $0 \leq \varepsilon t \leq \tau_*$ the variation of H, λ along the true motion is described by the solution h_3, λ_3 to within $O(\varepsilon)$.

2°. Let λ_* be the value of the parameter λ at the instant when the averaged solution reaches the separatrix: $\lambda_* = \lambda_3(\tau_*)$. Then the probabilities of capture of the point $x = (p_0, q_0, \lambda_0)$ into the domains G_1 and G_2 are calculated by the formulae

$$P_1(x) = \frac{\Theta_1(\lambda_*)}{\Theta_1(\lambda_*) + \Theta_2(\lambda_*)}, \quad P_2(x) = 1 - P_1(x). \quad (6.33)$$

3°. Let $h_1(\varepsilon t)$, $\lambda_1(\varepsilon t)$ and $h_2(\varepsilon t)$, $\lambda_2(\varepsilon t)$ be the solutions of the averaged system in the domains G_1 and G_2 with initial conditions “on the separatrix” glued to h_3, λ_3 : $h_{1,2}(\tau_*) = 0$, $\lambda_{1,2}(\tau_*) = \lambda_*$ (see Fig. 6.18). Then for most of the initial points x captured into the domain G_ν the variation of H , λ along the motion for $\tau_* \leq \varepsilon t \leq 1$ is described by the solution h_ν, λ_ν to within $O(\varepsilon + \varepsilon |\ln \varepsilon| / (1 + |\ln |h_\nu(\varepsilon t)||))$.

4°. The measure of the exceptional set of initial points whose motion cannot be described in this way does not exceed $O(\varepsilon^r)$ for any prescribed $r \geq 1$.

Thus, for describing the motion we must use the averaged system up to the separatrix, calculate the probability of capture into one or another domain on the separatrix, and again use, starting from the separatrix, the averaged system in the domain into which the capture occurred. This scheme of analysis of the problem was first used in [386, 387] in the study of motion of charged quasi-particles.

The detailed proofs of assertions 1°–4° are contained in [447] for $r = 1$, and in [459] for any r .

Remark 6.9. The approach to introducing the notion of probability in the deterministic problem that we considered above can be interpreted as follows. The initial conditions are regarded as random, uniformly distributed in a ball of radius δ . Then capture into a given domain becomes a random event and its probability can be calculated. After successive passages to the limit as $\varepsilon \rightarrow 0$ and then as $\delta \rightarrow 0$ the limit value of this probability is called the probability of capture in the original deterministic problem. There is another possible approach to introducing the probability [237, 605]. Namely, the initial conditions are fixed, but the system is subjected to a random perturbation – white noise with variance $\varepsilon\delta$ (other random perturbations with sufficiently strong mixing properties can also be considered [237]). In the problem thus modified, capture into a given domain becomes a random event. The limit value of the probability of this event as $\varepsilon \rightarrow 0$ and then as $\delta \rightarrow 0$ is called the probability of capture in the original problem. In the cases considered in [237, 605] this approach also leads to formulae (6.33) for the probability of capture.

We now explain the origin of the formulae for probability (6.33). In the domain G_3 the phase point describes almost closed curves returning repeatedly

to the ray $C\xi$ – the bisector of the angle between the separatrices at the saddle point (Fig. 6.19). Let h' denote the value of the energy of the point at the instant when it reaches this ray for the last time; then, obviously, $\lambda \approx \lambda_*$ (for most of the initial conditions, with the exception of the points that get stuck near the saddle for a long time). We set $\Theta_\nu^* = \Theta_\nu(\lambda_*)$, $\nu = 1, 2, 3$. The further motion of the point is determined by the value of h' .

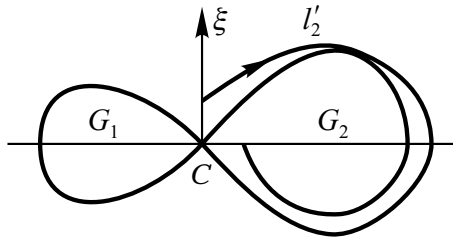

Fig. 6.19.

Proposition 6.2. *There exists a constant $k > 0$ such that the following holds. If $k\varepsilon^{3/2} < h' < \varepsilon\Theta_2^* - k\varepsilon^{3/2}$, then the point is captured into G_2 . If $\varepsilon\Theta_2^* + k\varepsilon^{3/2} < h' < \varepsilon\Theta_3^* - k\varepsilon^{3/2}$, then the point is captured into G_1 . We necessarily have $h' < \varepsilon\Theta_3^* + k\varepsilon^{3/2}$.*

◁ Fig. 6.19 shows a segment of the perturbed trajectory l'_2 close to l_2 and resulting in a capture into the domain G_2 . The change of the energy along this segment is approximately equal to $-\varepsilon\Theta_2^*$. Similarly, the change of the energy along a segment of the trajectory l'_3 close to $l_3 = l_1 \cup l_2$ and resulting in a capture into G_1 is approximately equal to $-\varepsilon\Theta_3^*$. One can show that the error of these approximations is of order $\varepsilon^{3/2}$. Consequently, we obtain the following picture to within small quantities of higher order. The value h' belongs to the segment $d_3 = (0, \varepsilon\Theta_3^*)$. If the value h' lies in the segment $d_1 = (\varepsilon\Theta_2^*, \varepsilon\Theta_3^*) \subset d_3$, then the point is captured into G_1 ; if the value h' lies in the segment $d_2 = d_3 \setminus d_1$, then the point is captured into G_2 . ▷

The flows of phase volume through the segments d_1 and d_2 are approximately equal to their lengths (since in a Hamiltonian system the flow of phase volume through a curve is equal to the difference of the values of the Hamiltonian at the ends of the curve). Hence the volumes of the sets of phase points in a neighbourhood of an initial point x flowing through the segments d_1 and d_2 are proportional in the principal approximation to the lengths of these segments. By the definition of the probability (6.29) we have, as required,

$$P_1 = \frac{\text{length } d_1}{\text{length } d_3} = \frac{\Theta_1^*}{\Theta_1^* + \Theta_2^*}, \quad P_2 = 1 - P_1.$$

The argument given above enables one to calculate the probabilities in all similar problems (for other types of the phase portrait, other combinations of the signs of the quantities Θ_ν ; cf. Example 6.11 below).

The probability of capture depends on the initial point only via the value of the parameter λ at the instant of reaching the separatrix. It is natural to call the quantities

$$Q_1(\lambda) = \frac{\Theta_1(\lambda)}{\Theta_1(\lambda) + \Theta_2(\lambda)}, \quad Q_2(\lambda) = 1 - Q_1(\lambda)$$

the probabilities of capture into G_1 and G_2 , respectively, for reaching the separatrix with a given value of λ . These quantities can be calculated independently of the initial point. Then the probabilities of capture for a given initial point can be calculated by the formulae $P_\nu(x) = Q_\nu(\lambda_*)$, $\nu = 1, 2$.

We now list some problems where the described phenomena arise: the formation of the resonance 3:2 between the axial and orbital rotation of Mercury [260]; the tidal theory of formation of the binary orbital resonances in the system of satellites of Saturn [64, 267, 276, 450, 556]; formation of the Kirkwood gap for the resonance 3:1 in the asteroid belt [458, 604]; scattering of quasi-particles – conductivity carriers in metals and semiconductors – on singular points of an isoenergy surface [387]; propagation of short radiowaves in the ionosphere waveguide channels [268]; motion of charged particles in the field of an evolving wave [93, 95]; electron cyclotron resonance heating of plasma in magnetic traps [467, 564]; motion of charged particles in the tail of the Earth's magnetosphere [156]; tumbling of a rigid body with a fixed point under the influence of small perturbations [452]; evolution in the Lorenz system for large Rayleigh numbers [428, 566, 613]; desynchronization of globally coupled phase oscillators [596]. We consider one example in more detail.

Example 6.11 ([93, 260, 450]). The equation of motion of a pendulum in the presence of small perturbations – a constant external torque, a dissipative momentum, a slow variation of the frequency – has the form

$$\ddot{q} + \omega^2(\lambda) \sin q = -\varepsilon[L + K\dot{q}], \quad \dot{\lambda} = \varepsilon; \quad L, K = \text{const.}$$

The phase cylinder of the unperturbed problem is shown in Fig. 6.20. The separatrices l_1 and l_2 divide the phase portrait into the domains of direct rotation G_1 , reverse rotation G_2 , and oscillations G_3 . Suppose that $L \geq 0$, $K \geq 0$, $\omega' = d\omega/d\lambda \geq 0$, and $L^2 + K^2 \neq 0$. Then under the influence of

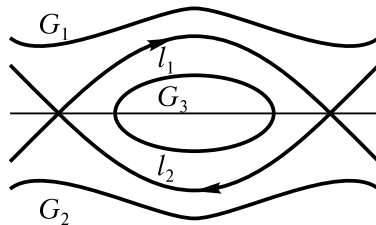

Fig. 6.20.

the perturbation, phase points in the domain of direct rotation approach a separatrix and either are captured into oscillations or go into reverse rotation.

The motion in each domain up to the separatrices is described by the averaged equation. This equation reduces to a linear one if the action variable I of the pendulum is used instead of the energy. In the domain of direct rotation the averaged equation has the form

$$\dot{I} = -\varepsilon(KI + L)$$

and the behaviour of I is described by the formula

$$I = \left(I_0 + \frac{L}{K}\right)e^{-K(\lambda-\lambda_0)} - \frac{L}{K} \quad \text{if} \quad K \neq 0;$$

for $K = 0$ we have $I = I_0 - L(\lambda - \lambda_0)$. The value λ_* of the parameter λ corresponding to the instant of reaching the separatrix is determined from the condition $2\pi I_0 = 8\omega(\lambda_*)$ (the right-hand side of this equation is half of the area of the oscillatory domain). In the case of capture into oscillations the motion for $\lambda > \lambda_*$ is described by the formula $I = (8\omega(\lambda_*)/\pi)e^{-K(\lambda-\lambda_*)}$. In the case of going into reverse rotation the motion for $\lambda > \lambda_*$ is described by the formula

$$I = \left(\frac{4\omega(\lambda_*)}{\pi} - \frac{L}{K}\right)e^{-K(\lambda-\lambda_*)} + \frac{L}{K} \quad \text{if} \quad K \neq 0;$$

for $K = 0$ we have $I = \frac{4\omega(\lambda_*)}{\pi} + L(\lambda - \lambda_*)$.

The integrals along the separatrices introduced above can be easily calculated:

$$\Theta_{1,2} = 8K\omega + 8\omega' \pm 2\pi L.$$

If $\Theta_2 < 0$, then the probability of passing from direct rotation into oscillations is given by the formula $P = (\Theta_1 + \Theta_2)/\Theta_1$. If $\Theta_2 > 0$, then this probability is equal to 1 (since going into reverse rotation is impossible). Finally we obtain

$$P = \begin{cases} \frac{8(\omega' + K\omega)}{4(\omega' + K\omega) + \pi L}, & L > \frac{4(\omega' + K\omega)}{\pi}, \\ 1, & L \leq \frac{4(\omega' + K\omega)}{\pi}. \end{cases} \quad (6.34)$$

This formula with $\omega' = 0$ was used in [260] to explain the origin of the aforementioned resonance in the rotation of Mercury. \triangle

We now give the general statement of the problem of separatrix crossing in single-frequency²⁰ systems. In this problem the equations of the perturbed motion have the form

$$\dot{x} = v(x, \varepsilon), \quad x \in D \subseteq M^l, \quad 0 < \varepsilon \ll 1, \quad v(x, \varepsilon) = v_0(x) + \varepsilon v_1(x, \varepsilon).$$

²⁰ Some results on using the averaging method for describing the separatrix crossing in two-frequency systems are contained in [148, 605].

Here M^l is an l -dimensional manifold and D is a domain in M^l . We assume that the unperturbed ($\varepsilon = 0$) system has $l-1$ smooth²¹ integrals H_1, \dots, H_{l-1} which are independent almost everywhere in D (that is, the rank of their Jacobi matrix is equal to $l-1$ almost everywhere in D). We assume that the domain D contains, together with each point, also the entire common level line²² of the integrals passing through this point and that the non-singular common level lines are diffeomorphic to circles. The singular common level lines pass through the points where the integrals cease to be independent, that is, the rank of their Jacobi matrix is less than $l-1$. We call such a singular level line, as well as a union of such level lines, a separatrix (similarly to how for the unperturbed ($\varepsilon = 0$) system (6.30) the term separatrix was used both for a curve l_i in Fig. 6.14 for a given λ , and for a surface in the space of p, q, λ composed of such curves). The influence of the perturbation gives rise to evolution, in the course of which phase points can cross a separatrix.

We assume that in the domain D

- a) the rank of the Jacobi matrix of the map $\mathcal{H}: D \rightarrow \mathbb{R}^{l-1}$ given by $\mathcal{H}(x) = (H_1(x), \dots, H_{l-1}(x))$ is almost everywhere equal to $l-1$, drops to $l-2$ on a smooth $(l-2)$ -dimensional surface, and is everywhere greater than $l-3$, and
- b) at the equilibrium positions of the unperturbed system two eigenvalues are non-zero (the other eigenvalues are equal to 0 because of the existence of the integrals).

Then the unperturbed system is a Nambu system [445] (a polyintegrable system [80]). This means that in the subdomain of M^l under consideration we can choose the volume element so that the volume of the parallelepiped spanned by vectors $v_0, a_1, \dots, a_{l-1} \in T_x M^l$ is equal to the standard volume of the parallelepiped²³ spanned by the vectors $(dH_1(a_j), \dots, dH_{l-1}(a_j)) \in \mathbb{R}^{l-1}$, $j = 1, \dots, l-1$ (for any a_1, \dots, a_{l-1}). The coordinate formulation: the rate of change of any function $F(x)$ along the trajectories of the unperturbed system is

$$\dot{F} \equiv \frac{\partial F}{\partial x} v_0 = \frac{1}{\mu(x)} \det \left(\frac{\partial(F, H_1, \dots, H_{l-1})}{\partial x} \right),$$

where $\mu(x)$ is a given non-vanishing function depending on the choice of the coordinate system. The phase flow of a Nambu system preserves volumes [80].

²¹ In [468, 469, 594] separatrix crossings were considered in problems where the integrals have singularities at equilibrium positions of the system.

²² That is, the connected component of the common level set.

²³ The general definition in [80] also includes the possibility of choosing the volume element in the space of values of the integrals, which makes the definition invariant under transformations in this space. The theory of polyintegrable systems is also related to the Fermi surfaces in physics of solids and is interesting in its own right [84, 89, 220, 494].

The integrals H_1, \dots, H_{l-1} and the volume element in M^l (in the coordinate formulation, the function $\mu(x)$) completely determine the vector field v_0 . If among the integrals H_1, \dots, H_{l-1} there are $l - 2$ independent ones, whose values can be taken for new variables λ , then the unperturbed system is Hamiltonian on a two-dimensional surface $\lambda = \text{const}$. If in this Hamiltonian system one can use a single chart of canonical variables (p, q) in a neighbourhood of the entire separatrix, then the equations of the perturbed motion take the form (6.30). One can also consider separatrix crossings directly for perturbations of a Nambu system. The phase space of the averaged system is the set of common level lines of the integrals of the unperturbed system, which has the natural structure of a manifold with singularities [136] (singularities correspond to a separatrix). The averaged system approximately describes the evolution of the slow variables – the values of the integrals of the unperturbed system. The estimates of the accuracy of the description given above for systems of the form (6.30) remain valid. The probabilities of falling into different domains after a separatrix crossing are expressed in terms of the ratios of the quantities

$$\tilde{\Theta}_i(\lambda) = - \oint_{l_i} \left(\beta_1(\lambda) \frac{\partial H_1}{\partial x} + \dots + \beta_{l-1}(\lambda) \frac{\partial H_{l-1}}{\partial x} \right) v_1(x, 0) dt, \quad (6.35)$$

where λ parametrizes the surface of singular points (“saddles”) of the unperturbed system, the β_j are coefficients such that the expression in parentheses in the integrand vanishes at a singular point, and $l_i = l_i(\lambda)$ is a separatrix. (Such coefficients β_j do exist, since the integrals H_j , $j = 1, \dots, l - 1$, are dependent at a singular point; the coefficients β_j are defined up to a common factor.)

Example 6.12 ([452, 465]). The evolution of rotation of a rigid body under the action of a perturbing torque that is constant with respect to axes attached to the body (for example, the torque of a gas leak from the orientation system of an artificial satellite) is described by the Euler dynamical equations (§ 1.2.4) of the form

$$\begin{aligned} A_1 \dot{\omega}_1 + (A_3 - A_2) \omega_2 \omega_3 &= \varepsilon M_1, \\ A_2 \dot{\omega}_2 + (A_1 - A_3) \omega_1 \omega_3 &= \varepsilon M_2, \\ A_3 \dot{\omega}_3 + (A_2 - A_1) \omega_1 \omega_2 &= \varepsilon M_3, \end{aligned} \quad (6.36)$$

where $\omega_1, \omega_2, \omega_3$ are the projections of the angular velocity of the body onto the principal central inertia axes, the εM_i are the projections of the perturbing torque onto these axes, and A_1, A_2, A_3 are the principal central moments of inertia of the body. Suppose that $A_1 > A_2 > A_3$, $M_1 \geq 0$, and $M_3 \geq 0$. The unperturbed ($\varepsilon = 0$) polyintegrable system is the Euler–Poincaré problem; its integrals are the kinetic energy of the body E and the square of the magnitude of the angular momentum G^2 :

$$E = \frac{1}{2} (A_1 \omega_1^2 + A_2 \omega_2^2 + A_3 \omega_3^2), \quad G^2 = A_1^2 \omega_1^2 + A_2^2 \omega_2^2 + A_3^2 \omega_3^2.$$

For real motions, $0 \leq 2A_3E \leq G^2 \leq 2A_1E$. In the space of angular velocities the equation $G^2 = 2A_2E$ defines two intersecting planes filled with the separatrices of the Euler–Poincaré problem (Fig. 6.21). These planes divide the

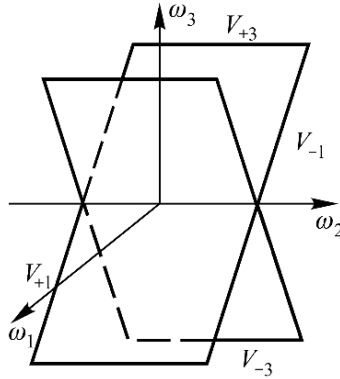

Fig. 6.21.

space into four domains $V_{\pm i}$, $i = 1, 3$: the domain V_{+i} (respectively, V_{-i}) contains the positive (negative) ray of the axis ω_i . Under the influence of the perturbation ($\varepsilon \neq 0$) the body, having started the motion with an angular velocity in one of the domains V_{-1}, V_{-3} , slows down, tumbles (crossing the separatrix), and then starts rotating with an angular velocity in one of the domains V_{+1}, V_{+3} . We set

$$\mu = \frac{M_1}{M_3} \sqrt{\frac{(A_1 - A_2)A_3}{(A_2 - A_3)A_1}}.$$

Calculations show that for $\mu < 1$, from the domain V_{-1} the body is captured into V_{+3} with probability 1; from the domain V_{-3} the body is captured into V_{+1} with probability μ , and into V_{+3} with probability $1 - \mu$ (Fig. 6.22). The probabilities for $\mu > 1$ are obtained by replacing μ by $1/\mu$ and interchanging the indices 1 and 3. If at first the angular velocity lies in one of the domains V_{+1}, V_{+3} not too close to a separatrix (at a distance from a separatrix of

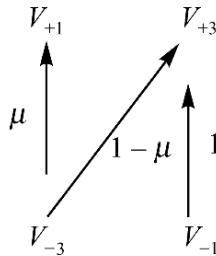

Fig. 6.22.

order greater than ε), then the angular velocity remains in the corresponding domain during the entire motion. \triangle

6.2 Averaging in Hamiltonian Systems

The problem of the influence of small Hamiltonian perturbations on an integrable Hamiltonian system was called by Poincaré the *fundamental problem of dynamics*. This problem has many applications; it is for this problem that the historically first formulations of the averaging principle were stated and the first results of perturbation theory were obtained. The formal aspect of the theory is here basically the same as for general non-Hamiltonian perturbations. But the nature of evolution under the influence of Hamiltonian perturbations is quite different. Correspondingly, the methods used for justifying the recipes of perturbation theory are essentially different from those in the non-Hamiltonian case.

6.2.1 Application of the Averaging Principle

Suppose that the unperturbed Hamiltonian system is completely integrable, some domain of its phase space is foliated into invariant tori, and the action-angle variables I, φ are introduced in this domain:

$$I = (I_1, \dots, I_n) \in B \subset \mathbb{R}^n, \quad \varphi = (\varphi_1, \dots, \varphi_n) \bmod 2\pi \in \mathbb{T}^n.$$

The Hamiltonian H_0 of the unperturbed system depends only on the action variables: $H_0 = H_0(I)$. The equations of the unperturbed motion have the usual form:

$$\dot{I} = 0, \quad \dot{\varphi} = \frac{\partial H_0}{\partial I}.$$

Suppose that the system is subjected to a small Hamiltonian perturbation. The perturbed motion is described by the system with Hamiltonian

$$\begin{aligned} H &= H_0(I) + \varepsilon H_1(I, \varphi, \varepsilon): \\ \dot{I} &= -\varepsilon \frac{\partial H_1}{\partial \varphi}, \quad \dot{\varphi} = \frac{\partial H_0}{\partial I} + \varepsilon \frac{\partial H_1}{\partial I}. \end{aligned} \tag{6.37}$$

The perturbing Hamiltonian $H_1(I, \varphi, \varepsilon)$ has period 2π in φ . This form of equations is standard for applying the averaging principle. Unless stated otherwise, we assume the functions H_0, H_1 to be analytic.

Remark 6.10. One often encounters problems in which the perturbation depends periodically also on time t . This case reduces to the one considered above by introducing the new phase $\varphi_{n+1} = t$ and its conjugate variable I_{n+1} . The variation of the extended set of phase variables is described by a system of equations of the same standard form (6.37) with the Hamiltonian

$$H' = I_{n+1} + H_0(I_1, \dots, I_n) + \varepsilon H_1(I_1, \dots, I_n, \varphi_1, \dots, \varphi_n, \varphi_{n+1}, \varepsilon).$$

Suppose that the frequencies $\partial H_0/\partial I_j$ do not satisfy identical linear relations with integer coefficients. In accordance with the principle of § 6.1.1 for approximate description of the evolution of the variables I we average equations (6.37) over the phases φ .

Theorem 6.13. *In a Hamiltonian system with n degrees of freedom and n frequencies there is no evolution of the slow variables in the sense that the averaged system has the form $\dot{J} = 0$.*

◁ When calculating the integral of $\partial H_1/\partial \varphi_j$ over the n -dimensional torus we can first integrate with respect to the variable φ_j . This single integral is equal to the increment of the periodic function H_1 over the period, that is, to zero. ▷

Remark 6.11. To preserve the Hamiltonian form of the equations we slightly generalize the principle of § 6.1.1: we average also the second equation (6.37) describing the variation of the angles (phases) φ . The resulting averaged system has the Hamiltonian

$$\mathcal{H}(J, \varepsilon) = H_0(J) + \varepsilon \mathcal{H}_1(J), \quad \mathcal{H}_1 = \langle H_1(J, \varphi, 0) \rangle^\varphi.$$

Hence the phases undergo the uniform rotation with frequencies $\partial \mathcal{H}/\partial J$.

Example 6.13. Consider the *planar restricted circular three-body problem* (§ 2.5). Let ε denote the mass of Jupiter, which we assume to be small in comparison with the mass of the Sun. This system has two and a half degrees of freedom (two degrees of freedom plus the explicit periodic dependence on time). Passing to a uniformly rotating barycentric²⁴ coordinate system one of whose axes is directed to Jupiter and the other is perpendicular to the first and lies in the plane of Jupiter's orbit (Fig. 6.23) we obtain a system with two degrees of freedom.

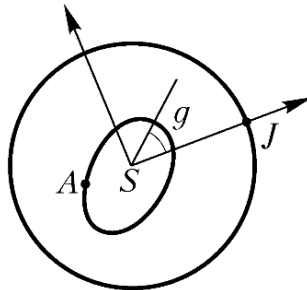

Fig. 6.23.

For $\varepsilon = 0$ we obtain the unperturbed two-body problem in the rotating coordinate system. In its phase space the domain of elliptic motions is foliated into two-dimensional invariant tori. For the action–angle variables we

²⁴ With origin at the centre of mass of the system Sun–Jupiter.

can choose the canonical Delaunay elements L, G, l, g (see Ch. 5): $L = \sqrt{a}$, $G = \sqrt{a(1 - e^2)}$, a and e are the major semiaxis and the eccentricity of the asteroid's orbit, l is the mean anomaly of the asteroid, g is the longitude of the pericentre of the orbit measured from the direction to Jupiter (Fig. 6.23). The Delaunay elements are the canonical variables in the phase space. They can also be used for describing the perturbed motion. We average the perturbed equations for the Delaunay elements over the fast phases l and g . By Theorem 6.13 and Remark 6.11, in the averaged system the quantities L, G (and therefore a, e) are integrals, and the phases l, g rotate uniformly with frequencies differing from the unperturbed frequencies by quantities of order ε . Thus, the averaging principle gives the following picture of the motion. The asteroid moves along an ellipse which slowly uniformly rotates around its focus (the centre of mass of the system Sun–Jupiter). \triangle

Example 6.14. Consider the rotation of a heavy rigid body around a fixed point. We denote the distance from the suspension point to the centre of mass of the body by ε and assume it to be a small quantity. For $\varepsilon = 0$ we obtain the Euler–Poincaré problem (Ch. 5). The action–angle variables $I_1, I_2, \Theta, \varphi_1, \varphi_2, \vartheta$ for this problem are described in [27] (see also § 3.2.3). Recall that I_2 is the length of the angular momentum vector of the body, Θ its vertical projection, ϑ the rotation angle of the angular momentum vector around the vertical, and the variables $I_1, \varphi_1, \varphi_2$ for given I_2 determine the position of the body in a system of axes rigidly attached to the angular momentum vector and the vertical (Fig. 3.1). In these variables the Hamiltonian of the perturbed problem has the form

$$H = H_0(I_1, I_2) + \varepsilon H_1(I_1, I_2, \varphi_1, \varphi_2, \Theta).$$

Since Θ is an integral of the problem, we obtain for the I_j, φ_j a system with two degrees of freedom and two frequencies. Applying the averaging principle we obtain that the “actions” I_j are integrals, while the phases φ_j undergo uniform rotation close to the rotation in the Euler–Poincaré problem. It easily follows from the analysis of the equation $\dot{\vartheta} = \varepsilon \partial H_1 / \partial \Theta$ that in this approximation the variation of the angle ϑ is close to the uniform rotation with angular velocity of order ε . Thus, we obtain that in the coordinate system attached to the angular momentum vector and the vertical, the body moves “almost according to Euler–Poincaré”, while the angular momentum vector itself slowly precesses around the vertical. \triangle

One often encounters problems with *proper degeneracy* (§ 5.2.1), in which the unperturbed Hamiltonian depends not on all the action variables and, correspondingly, some of the unperturbed frequencies are identically equal to zero:

$$H = H_0(I_1, \dots, I_r) + \varepsilon H_1(I, \varphi, \varepsilon), \quad r < n.$$

The phases $\varphi_j, j > r$, are slow variables. According to the averaging principle, for approximate description of the evolution we must average the equations of

the perturbed motion over the fast phases φ_i , $i \leq r$. The following assertion can be proved similarly to the preceding one.

Theorem 6.14. *In a Hamiltonian system with n degrees of freedom and r frequencies, $r < n$, the variables conjugate to the fast phases are integrals of the averaged system.*

According to this theorem the averaging results in a reduced Hamiltonian system with $n - r$ degrees of freedom for the slow phases and their conjugate variables. If the number of fast phases is only by one less than the number of degrees of freedom (simple degeneracy), then the reduced system has one degree of freedom. Consequently, in the case of simple degeneracy the averaging principle allows one to approximately integrate the problem (as in the non-degenerate case).

Example 6.15 (Gauss' problem). We consider the (non-planar) *restricted circular three-body problem*. We assume the mass of Jupiter to be small compared to the mass of the Sun. In the canonical Delaunay elements $L, G, \Theta, l, g, \vartheta$ (Ch. 2) the equations of motion with respect to the rotating reference frame introduced in the description of Example 6.13 have simple degeneracy – the angle g (the argument of the latitude of the asteroid's pericentre) is constant in the unperturbed motion. The averaging over the fast phases l, ϑ in this problem is called *Gauss' averaging*. By Theorem 6.14 the quantities L, Θ are integrals of the averaged system. The variation of G, g after averaging is described by a Hamiltonian system with one degree of freedom whose Hamiltonian depends on L, Θ as parameters. The phase portraits of this system for all L, Θ were constructed in [595] (with the aid of computer, since the Hamiltonian has a rather complicated form). This problem has been studied analytically in four limiting cases: for small inclinations, in the Hill case where Jupiter is much farther from the Sun than the asteroid [383], in the outer Hill case where the asteroid is much farther from the Sun than Jupiter [623], and in the case where the orbits of the asteroid and Jupiter are uniformly close [385].

For small inclinations the motion is qualitatively the same as in the planar problem.²⁵

In the analysis of the Hill case the following new phenomenon was discovered: orbits with large inclinations acquire considerable oscillations of the eccentricity. In particular, for an orbit that is initially almost circular with inclination 90° , the eccentricity increases to 1, which means that the orbit turns into a segment and the asteroid collides with the Sun. Perhaps, this explains why the Solar System is almost planar, and why spherically symmetric planets have no satellites with large inclinations to the plane of the Solar System. Uranus has such satellites: this planet rotates “on a side”, its equator is inclined to the plane of its orbit at 98° , and the planes of the satellites' orbits are

²⁵ If the inclination is small at the initial instant, then in the averaged system it remains small during the entire motion [449].

close to the plane of the equator. The fact that the gravitational field of Uranus is non-central (the compression of Uranus is about $1/17$) makes the orbits of its satellites stable in the approximation by the averaging method [383].

Another new phenomenon discovered in the analysis of the Hill case is the Lidov–Kozai resonance: the existence of orbits for which the argument of the latitude of the pericentre (the angle g between the direction from the Sun to the pericentre of the unperturbed orbit of the asteroid and the line of nodes, which is the intersection line of the planes of the orbits of the asteroid and Jupiter) slowly oscillates about the value $\pi/2$ or $3\pi/2$ with period equal to the oscillation period of the eccentricity. (The word “resonance” is used here for historic reasons; of course, there is not any resonance in this situation, but there are oscillatory domains on the phase portrait of the variables G, g .) These motions were discovered by Lidov [382], and Kozai repeated this study in different variables and gave a graphic representation of the results on the phase plane [321].

In the outer Hill case the plane of the asteroid’s orbit slowly precesses around the normal to the plane of Jupiter’s orbit, and the orbit itself slowly rotates in its plane as a rigid body. For vertical orbits there is no precession. For orbits with inclination $\arccos(1/\sqrt{5})$ there is no rotation in the plane of the orbit.²⁶ \triangle

Example 6.16 (Laplace–Lagrange theorem on the stability of the Solar System). Consider the n -body problem under the assumption that the mass of one body (the Sun) is much larger than the masses of the other bodies (the planets). Here, the unperturbed system is by definition the one in which the planets do not interact with each other, and the Sun is at rest. The unperturbed system decomposes into $n - 1$ Kepler’s problems. We suppose that the unperturbed orbits of the planets are Keplerian ellipses and introduce for describing each of them the *canonical Poincaré elements*²⁷ [20]. As a result we obtain canonical variables for the perturbed system. In the problem under consideration there are $n - 1$ fast phases – the mean longitudes of the planets. Their conjugate variables $A_j = \sqrt{\mu_j a_j}$, $j = 1, \dots, n - 1$, are integrals of the system averaged over the fast phases. Here the a_j are the major semiaxes of the Keplerian elliptic orbits of the planets, and the μ_j are factors depending on the masses. Thus, in the averaged system the major semiaxes of the

²⁶ The orbit of a distant satellite of an axially symmetric planet evolves in exactly the same way (see, for example, [101]).

²⁷ These elements are canonical variables in which the problem is regular for small eccentricities and inclinations. The Poincaré elements $A, \xi, p, \lambda, \eta, q$ are connected with the Delaunay elements $L, G, \Theta, l, g, \vartheta$ by the relations

$$\begin{aligned} A &= L, & \xi &= \sqrt{2(L - G)} \cos(g + \vartheta), & p &= \sqrt{2(G - \Theta)} \cos \vartheta, \\ \lambda &= l + g + \vartheta, & \eta &= -\sqrt{2(L - G)} \sin(g + \vartheta), & q &= -\sqrt{2(G - \Theta)} \sin \vartheta. \end{aligned}$$

For zero eccentricities and inclinations we have $\xi = \eta = p = q = 0$. The variable λ is the *mean longitude* of the planet.

planets' orbits do not evolve. This important conclusion is called the Laplace theorem on the absence of secular perturbations of the semi-axes.

Furthermore, it turns out that the averaged system has a stable equilibrium position corresponding to the motion of all the planets in one plane in the same direction in circular orbits. The motion of the planets corresponding to small oscillations in the averaged system linearized about this equilibrium position is called the *Lagrangian motion*. It has a simple geometric interpretation. Consider the vector directed from the focus to the perihelion of a planet of length proportional to the planet's eccentricity (the *Laplace vector*). Then the projection of the Laplace vector onto the base plane of the coordinate system is a sum of $n - 1$ uniformly rotating vectors. The set of angular velocities of these vectors is the same for all the planets. The vector directed along the intersection line of the plane of the planet's orbit and the base plane (the line of nodes) of length proportional to the inclination of the planet is a sum of $n - 2$ uniformly rotating vectors.²⁸

If at some instant the eccentricities and inclinations are sufficiently small, then in the averaged system they also remain small during the entire motion. In particular, it turns out that collisions of planets and escapes to infinity are impossible. This assertion is called the Laplace–Lagrange theorem on the stability of the Solar System. Since this theorem was proved in 1784 the central mathematical problem of celestial mechanics was to extend this conclusion on stability from the averaged system to the exact one. In this area many branches of the theory of dynamical systems originated, including perturbation theory and ergodic theory. Nowadays there have been considerable advances in solving this problem. It turns out that for sufficiently small masses of the planets a larger part of the domain of the phase space corresponding to the unperturbed motion in the same direction in Keplerian ellipses of small eccentricities and inclinations is filled with conditionally periodic motions close to the Lagrangian ones (see § 6.3). Thus, “stability” takes place for most of the initial conditions. For initial conditions in the exceptional set, the evolution of the major semi-axes, if any, happens very slowly: its mean rate is exponentially decreasing as the perturbation decreases linearly [40] (see § 6.3.4 below). However, it is still unknown whether such an evolution really happens, and whether it can moreover lead to the destruction of the planetary system.

△

²⁸ The vanishing of one frequency is related to the existence of the integral of the angular momentum of the system. It turns out that the sum of all $2n - 3$ frequencies of the Lagrangian motion is equal to 0 (Herman, 1997). There are no obvious natural reasons for the existence of this relation. Therefore Herman called this relation the “wild resonance”. The existence of this relation follows from the explicit formulae for the Hamiltonian of the Lagrangian motion (given, for example, in [20]). Discussion of the “wild resonance” and its effect on dynamics is contained in [55, 235].

The questions of the correspondence between the solutions of the exact and averaged systems in all the examples considered above are of general nature and can be solved in the framework of KAM theory; see § 6.3.

In the cases where the frequencies of the unperturbed motion are close to commensurability, for approximate description of the evolution one uses partial averaging taking into account resonances (§ 6.1.1). For Hamiltonian systems considered here such averaging obviously amounts to discarding in the Fourier expansion of the perturbed Hamiltonian all the harmonics whose phases vary rapidly under such commensurabilities. This procedure also produces integrals of the averaged system.

Theorem 6.15. *A Hamiltonian system partially averaged taking into account r independent resonances has $n - r$ integrals in involution that are linear combinations with integer coefficients of the original slow variables I_j .*

◁ We perform the symplectic change of variables $(I, \varphi) \mapsto (p, q)$ with generating function $W = (p, R\varphi)$, where R is an integer unimodular matrix whose first r rows form a basis of the minimal sublattice of \mathbb{Z}^n that contains the vectors of integer coefficients of the resonance relations considered and is such that if some vector of the form dl , $d \in \mathbb{N}$, $l \in \mathbb{Z}^m$, belongs to this sublattice, then the vector l also belongs to it; a matrix R does exist according to [164]. In the new variables, averaging amounts to discarding in the Hamiltonian the harmonics containing the phases q_{r+1}, \dots, q_n . Their conjugate quantities p_{r+1}, \dots, p_n are integrals of the averaged system. ▷

If there is only one resonance, then the system partially averaged taking into account this resonance has $n - 1$ integrals in involution (different from the energy integral) and, consequently, is integrable.

Example 6.17. Suppose that in the *planar restricted circular three-body problem* the period of the unperturbed motion of the asteroid is close to half of the period of Jupiter's revolution.

We use the canonical variables L, G, l, g of Example 6.13. The quantity $l + 2g$ is a slow variable. The generating function W and the new variables p_j, q_j introduced in the proof of Theorem 6.15 are given by the formulae

$$\begin{aligned} W &= p_1(l + 2g) + p_2(-l - g), \\ p_1 &= G - L, & q_1 &= l + 2g, \\ p_2 &= G - 2L, & q_2 &= -l - g. \end{aligned}$$

After averaging taking into account the resonance, the quantity p_2 becomes an integral, and for p_1, q_1 we obtain a Hamiltonian system with one degree of freedom. Its phase portrait for small p_1 and various values of p_2 is shown in Fig. 6.24. In the portrait we have chosen $-p_1 = -\sqrt{L}(\sqrt{1 - e^2} - 1) \approx \sqrt{L}e^2/2$ and q_1 as polar coordinates.

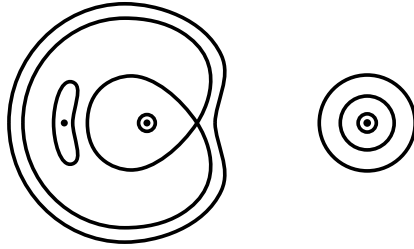

Fig. 6.24. △

In the case of a single resonance the phase portrait of the averaged system is close to the phase portrait of the problem of the motion of a pendulum in a conservative field (under fairly general assumptions) [41]. Indeed, in the variables p, q introduced in the proof of Theorem 6.15, the averaged Hamiltonian has the form

$$F = F_0(p_1, p_2, \dots, p_n) + \varepsilon F_1(p_1, p_2, \dots, p_n, q_1).$$

Let $p_1^* = p_1^*(p_2, \dots, p_n)$ be a simple resonant value of p_1 , that is,

$$\left. \frac{\partial F_0}{\partial p_1} \right|_{p_1^*} = 0, \quad \left. \frac{\partial^2 F_0}{\partial p_1^2} \right|_{p_1^*} = a \neq 0.$$

In its $\sqrt{\varepsilon}$ -neighbourhood we introduce the new variable $P_1 = (p_1 - p_1^*)/\sqrt{\varepsilon}$ and, correspondingly, the new Hamiltonian $\Phi = F/\sqrt{\varepsilon}$. If the original Hamiltonian F is regular in a neighbourhood of the resonance, then

$$\begin{aligned} \Phi &= \sqrt{\varepsilon} \left(\frac{1}{2} a P_1^2 + V(q_1) \right) + O(\varepsilon), \\ V(q_1) &= F_1(p_1^*, p_2, \dots, p_n, q_1). \end{aligned} \tag{6.38}$$

We shall omit the explicit dependence of a, V on the parameters p_2, \dots, p_n . If the remainder $O(\varepsilon)$ is discarded in (6.38), then we obtain the Hamiltonian problem of the motion of a pendulum in a conservative field, whose phase portrait is shown in Fig. 6.25. In the phase portrait there are the domains of

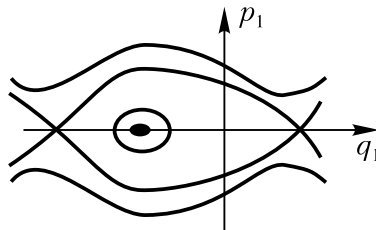

Fig. 6.25.

oscillatory and rotational motions of the pendulum separated by the separatrices. The typical size of the oscillatory domain in the variable p_1 and the typical amplitude of oscillations of p_1 are of order $\sqrt{\varepsilon}$; the typical period of oscillations is of order $1/\sqrt{\varepsilon}$. The equilibria in Fig. 6.25 are called stationary resonance regimes. When the variables q_2, \dots, q_n are taken into account, to these equilibria there correspond conditionally periodic motions (if the number of degrees of freedom is $n = 2$, then periodic motions).

Remark 6.12. If in the domain of variables under consideration the Hamiltonian is not a regular function, then the phase portrait of the averaged system can be different from that in Fig. 6.25. This happens in the problem of Example 6.17 if small values of the eccentricity are considered (cf. Fig. 6.24 and 6.25).

Remark 6.13. The effects connected with resonances occur surprisingly often in nature. The large perturbations of Saturn by Jupiter (“the great inequality”) are connected with the 2 : 5 commensurability of their Keplerian frequencies. The ratio of Neptune’s and Pluto’s Keplerian frequencies is approximately 3 : 2 (and therefore, although the projections of their orbits onto the ecliptic plane intersect, close encounters of these planets do not happen). The ratio of Uranus’ and Neptune’s Keplerian frequencies is approximately 2 : 1. Three resonance relations are known in the satellite system of Saturn: the ratio of the frequencies of Mimas and Tethys is (approximately) 2 : 1; of Enceladus and Dione, also 2 : 1; of Titan and Hyperion, 4 : 3. Furthermore, these three resonance relations are so accurate that for each of them there is an oscillating resonant angle variable—a linear combination with integer coefficients of the mean longitudes of the satellites and the longitudes of the nodes or pericentres of their orbits. In addition, the ratio of the frequencies of Mimas and Enceladus, as well as of Tethys and Dione, are approximately 3 : 2, but the accuracy of these relations is worse than that of the preceding three. In the satellite system of Jupiter the ratios of the orbital frequencies of Io, Europa, and Ganymede are approximately 4 : 2 : 1, and their mean longitudes l_i approximately satisfy the relation $l_1 - 3l_2 + 2l_3 = 180^\circ$. The frequency of the axial rotation of Mercury is 3/2 of its orbital frequency. Tables of commensurabilities occurring in the Solar System are given in [101]. In most cases the causes of the origin of these commensurabilities are unknown. The procedure of partial averaging considered above is successfully used for describing the motion near a commensurability.

6.2.2 Procedures for Eliminating Fast Variables

In §6.1.2 we described the remarkable changes of variables that allow one to formally eliminate the fast phases from the right-hand sides of the equations of motion. These changes of variables play a central role in all the questions related to averaging. In the case of Hamiltonian systems under consideration these changes of variables can be chosen to be symplectic. Below we describe the basic procedures for symplectic elimination of the fast phases.

A. Lindstedt’s Method

This is one of the first methods for eliminating the fast phases. Its present form was given by Poincaré in [41].

Consider a perturbed Hamiltonian system (6.37) with n degrees of freedom and n frequencies, and suppose that the frequencies do not satisfy any identical resonance relations. We try to find a symplectic near-identity change of variables $I, \varphi \mapsto J, \psi$ so that the new Hamiltonian \mathcal{H} depends only on the slow variables: $\mathcal{H} = \mathcal{H}(J, \varepsilon)$. We seek a generating function of the change of variables and the new Hamiltonian in the form of formal series in ε :

$$\begin{aligned} I &= J + \varepsilon \frac{\partial S}{\partial \varphi}, & \psi &= \varphi + \varepsilon \frac{\partial S}{\partial J}, \\ S(J, \varphi, \varepsilon) &= S_1(J, \varphi) + \varepsilon S_2(J, \varphi) + \dots, \\ \mathcal{H}(J, \varepsilon) &= \mathcal{H}_0(J) + \varepsilon \mathcal{H}_1(J) + \dots. \end{aligned} \tag{6.39}$$

The functions S_i must have period 2π in φ . The old and new Hamiltonians satisfy the relation

$$\mathcal{H}(J, \varepsilon) = H_0\left(J + \varepsilon \frac{\partial S}{\partial \varphi}\right) + \varepsilon H_1\left(J + \varepsilon \frac{\partial S}{\partial \varphi}, \varphi, \varepsilon\right).$$

Equating here the terms of the same order in ε we obtain the system of equations

$$\begin{aligned} \mathcal{H}_0(J) &= H_0(J), & \mathcal{H}_1(J) &= \frac{\partial H_0}{\partial J} \frac{\partial S_1}{\partial \varphi} + H_1(J, \varphi, 0), \\ \mathcal{H}_j(J) &= \frac{\partial H_0}{\partial J} \frac{\partial S_j}{\partial \varphi} + F_j(J, \varphi), & j &\geq 2. \end{aligned} \tag{6.40}$$

The function F_j is a polynomial in $\partial S_1/\partial\varphi, \dots, \partial S_{j-1}/\partial\varphi$. In the notation $\langle \cdot \rangle^\varphi, \{ \cdot \}^\varphi$ for the averaging operator and the integration operator introduced in §6.1.2, the solution of system (6.40) is given by the formulae

$$\begin{aligned} \mathcal{H}_1 &= \langle H_1 \rangle^\varphi, & S_1 &= -\{H_1\}^\varphi + S_1^0(J), \\ \mathcal{H}_j &= \langle F_j \rangle^\varphi, & S_j &= -\{F_j\}^\varphi + S_j^0(J), & j &\geq 2, \end{aligned} \tag{6.41}$$

where the S_j^0 are arbitrary functions of J . One often chooses $S_j^0 \equiv 0$.

The expression for the integration operator (see §6.1.2) involves the denominators $(k, \omega(J)) = (k, \partial H_0 / \partial J)$ with integer vectors $k \neq 0$. Hence the functions S_j are undefined, generally speaking, on an everywhere dense set of points J where these denominators vanish or are abnormally small.

Let us forget temporarily about small denominators and suppose that the first m functions S_j are defined and smooth. We truncate the series for the function S at the terms of order ε^m and consider the change of variables with the “truncated” generating function

$$J\varphi + \varepsilon S_1(J, \varphi) + \cdots + \varepsilon^m S_m(J, \varphi).$$

For the new variables we obtain a Hamiltonian in which only the terms of order ε^{m+1} and higher depend on the phases. Discarding these terms we obtain an integrable system of equations, in which $J = \text{const}$ and the phase ψ uniformly rotates with a frequency depending on J . Substituting this solution into the formulae of the change of variables we obtain an approximate solution of the original system. Its accuracy and the time interval where it is useful are increasing as the approximation order m increases. On a time interval $(0, T)$ this solution guarantees the accuracy $O(\varepsilon^{m+1}T)$ for the slow variables, and $O(\varepsilon^{m+1}T^2)$ for the fast ones. For $m = 1$ we arrive at the averaged system. If the series for the change of variables were converging, then this procedure would make it possible to integrate the original perturbed system.

In order to give a real meaning to these arguments in the presence of small denominators we represent the perturbation in the form

$$\varepsilon H_1(I, \varphi, \varepsilon) = H^{(1)}(I, \varphi, \varepsilon) + H^{(2)}(I, \varphi, \varepsilon) + \cdots,$$

where $H^{(j)}$ is a trigonometric polynomial in φ whose absolute value is bounded by a quantity of order ε^j . We carry out the procedure for eliminating the phases described above regarding $H^{(j)}$ as a term of order ε^j in the expansion of the perturbation in a series in ε (“forgetting” here that the function $H^{(j)}/\varepsilon^j$ itself depends on ε). Then only finitely many small denominators appear in each approximation of the procedure and, correspondingly, the functions S_j , $1 \leq j \leq m$, will be undefined only on a finite set of surfaces $(k, \omega(J)) = 0$ (their number depends on ε and on the approximation order m). Outside a small neighbourhood of this collection of surfaces, the “truncated” generating function introduced above defines a change of variables approximately integrating the original system of equations. As before, the whole system of functions S_j , $1 \leq j < \infty$, is undefined, generally speaking, on an everywhere dense set of values of J .

Lindstedt’s method is very effective, since it gives a simple procedure for approximate integration of a perturbed Hamiltonian system. This method played an important role in the development of the theory, since it enabled one to construct an expansion of the general solution of the perturbed Hamiltonian system in a formal series containing only terms periodic in time. Poincaré

called the methods producing such expansions “new”, in contrast to the “old” methods in which *secular terms* were appearing of the form t^m and $t^m \sin lt$, $t^m \cos lt$; see [41]. The discovery of the “new” methods has completely changed the statement of the problem of stability of perturbed Hamiltonian systems (including the Solar System). The appearance of secular terms in the “old” methods, which was actually caused by the expansion technique (similar to how a secular term appears in the expansion $\sin(1+\varepsilon)t = \sin t + \varepsilon t \cos t + \dots$), was regarded as an indication of instability of the motion.²⁹ Efforts were directed towards proving the absence of such terms in the principal orders of the expansion for concrete perturbations. For the Solar System, Laplace proved the absence of secular terms in the first order in the perturbation. Poisson found that in the second order in the perturbation there are no pure secular terms (of the form t^m), but there are mixed ones (of the form $t^m \sin lt$, $t^m \cos lt$). When the “new” methods arrived, it turned out that it is possible to develop formal theories without secular terms, and the problem is in the convergence of the resulting expansions.

As noted by Poincaré, the Lindstedt series are divergent in the general case.

Example 6.18. Consider the following system, in which the frequencies of the unperturbed motion are constant and incommensurable:

$$H = \omega_1 I_1 + \omega_2 I_2 + \varepsilon \left(I_1 + \sum_k a_k \sin(k, \varphi) \right), \quad k \neq 0,$$

$$|(\omega, k)| > c|k|^{-\nu}, \quad c, \nu = \text{const} > 0, \quad a_k = \exp(-|k|).$$

Here we can calculate all the approximations of Lindstedt’s method. If the Lindstedt series were convergent, then the quantity $|I|$ would undergo only bounded oscillations along the motion.

On the other hand, the perturbed system can be easily integrated. The phases rotate uniformly with frequencies $\omega_1 + \varepsilon$, ω_2 and the variation of I is determined by a quadrature. If the frequency ratio $(\omega_1 + \varepsilon)/\omega_2$ is rational, then the quantity $|I|$ increases to infinity along the motion (as is easy to calculate). Hence the Lindstedt series diverge.³⁰ \triangle

As is often the case, divergence is connected with the fact that one constructs certain objects that actually do not exist. The situation here is roughly as follows. If for some J the Lindstedt series converge, then the perturbed system has an invariant torus $J = \text{const}$ on which the phase rotates with the

²⁹ Here it is Lagrange stability. A motion is said to be *Lagrange stable* if its trajectory remains forever in a bounded domain of the phase space.

³⁰ If the unperturbed system is non-degenerate (see the definition of non-degeneracy in § 3.1) and the perturbation is such that in the procedure of Lindstedt’s method no small denominators appear (all the functions S_i in (6.41) have no singularities), then the Lindstedt series converge [391].

frequency vector

$$\widehat{\omega}(J, \varepsilon) = \frac{\partial H_0(J)}{\partial J} + \varepsilon \frac{\partial \mathcal{H}_1(J)}{\partial J} + \dots .$$

The unperturbed frequencies are incommensurable (this is how the value of J was chosen). But the frequencies of the perturbed motion become commensurable for some ε . Then the invariant torus is foliated into tori of lower dimension. Such a situation is very degenerate and does not occur in generic systems. For this reason the Lindstedt series are divergent in the general case.

Remark 6.14. There is a variant of Lindstedt’s method in which one seeks the invariant tori with the incommensurable frequencies fixed beforehand. The corresponding series converge [35]. The proof of the convergence of these series in [35] was based on establishing that they are identical to converging sequences of changes of variables in KAM theory (see § 6.3). Later direct proofs of the convergence were given in [184, 185, 224, 227, 241, 242, 243, 253, 254].

B. Von Zeipel’s Method

This method extends the procedure of Lindstedt’s method to the case where only some of the phases are eliminated from the Hamiltonian. This method allows one to consider systems with proper degeneracy and resonance situations. Von Zeipel’s method surpasses the possibilities of the methods of Delaunay and Bohlin developed earlier for this purpose.

Suppose that system (6.37) is again subjected to a symplectic near-identity change of variables of the form (6.39). We seek a new Hamiltonian in the form of a formal series $\mathcal{H}(J, \psi, \varepsilon) = \mathcal{H}_0(J) + \varepsilon \mathcal{H}_1(J, \psi) + \dots$. The new and old Hamiltonians are related as follows:

$$\mathcal{H}_0(J) + \varepsilon \mathcal{H}_1\left(J, \varphi + \varepsilon \frac{\partial S}{\partial J}\right) + \dots = H_0\left(J + \varepsilon \frac{\partial S}{\partial \varphi}\right) + \varepsilon H_1\left(J + \varepsilon \frac{\partial S}{\partial \varphi}, \varphi, \varepsilon\right).$$

Equating the terms of the same order in ε we again obtain the system of relations (6.40), but the \mathcal{H}_i now depend on the phases, and the F_i are calculated differently.

Let $\chi \in \mathbb{T}^{n-r}$ be the set of phases that we wish to eliminate from the Hamiltonian, and let $\gamma \in \mathbb{T}^r$ be the remaining phases. Then one can take

$$\begin{aligned} \mathcal{H}_1 &= \langle H_1(J, \varphi, 0) \rangle^\chi, & S_1 &= -\{H_1 - \mathcal{H}_1\}^\varphi + S_1^0(J), \\ \mathcal{H}_j &= \langle F_j(J, \varphi) \rangle^\chi, & S_j &= -\{F_j - \mathcal{H}_j\}^\varphi + S_j^0(J), \quad j \geq 2, \end{aligned} \tag{6.42}$$

where the S_j^0 are arbitrary functions of J ; for example, one can choose $S_j^0 \equiv 0$.

If, as above, we truncate the series for S at the terms of order ε^m , consider the “truncated” change of variables, and discard the terms of order ε^{m+1} in the transformed Hamiltonian, then we obtain the Hamiltonian of the m th

approximation. This Hamiltonian is independent of the phases χ ; correspondingly, the resulting approximate system has $n - r$ integrals and reduces to a system with r degrees of freedom. As in Lindstedt's method, here small denominators appear. To ensure that in each approximation there are only finitely many small denominators we must modify the procedure described above, similarly to §6.2.2.A.

Suppose that we are considering a system with *proper degeneracy*, that is, the unperturbed Hamiltonian is independent of some of the action variables. Then among the phases there are slow and fast ones, and the procedure described above allows one to formally eliminate the fast phases from the Hamiltonian. The first-approximation system for the new variables coincides with the system averaged over the fast phases.

Now suppose that the unperturbed frequencies satisfy r independent resonance relations. We transform the phases so that under these relations the first r phases are semifast, and the last $n - r$ ones, fast. Then the procedure described above allows us to formally eliminate the fast phases from the Hamiltonian. The first-approximation system for the new variables coincides with the system partially averaged taking into account the given resonances. In practice, here one can work with the original variables, rather than introduce as variables the resonant combinations of the phases. Then in formulae (6.42) the averaging over the fast phases is replaced by the following operation: in the Fourier expansion we discard the harmonics which oscillate in the presence of the given resonance relations in the unperturbed motion.

The von Zeipel series, as the Lindstedt series, are divergent in the general case.

Instead of von Zeipel's method one often uses the modification of it suggested by Hori and Deprit (see, for example, [256]). In this modification a symplectic change of variables eliminating the phases is given not by a generating function, but by a *generator* – a function $W(J, \psi, \varepsilon) = W_1 + \varepsilon W_2 + \dots$ such that the shift by time ε along the trajectories of the Hamiltonian system with Hamiltonian W produces the required transformation $(I, \varphi) \mapsto (J, \psi)$. This is more convenient, since a generating function depends simultaneously on the old (φ) and new (J) variables, whereas a generator depends only on the new variables. Therefore, when using a generator, one does not have to solve additional functional equations in order to express everything in terms of only the old or only the new variables. There are simple recurrence relations expressing the coefficients of the expansions in ε of the new variables and the new Hamiltonian in terms of the old variables, the old Hamiltonian, and the generator. The coefficients of the expansion of the generator are consecutively determined from a system of relations equivalent to (6.42). For example, the first approximation for the generator simply coincides with the first approximation for the generating function: $W_1(J, \psi) \equiv S_1(J, \psi)$. There are computer programs realizing the Hori–Deprit procedure in symbolic form. One of these programs was used to improve the classical Delaunay theory of the Lunar motion [207].

C. Methods of KAM Theory

In the *Kolmogorov–Arnold–Moser (KAM) theory* there were developed converging methods for integrating perturbed Hamiltonian systems. These methods are based on constructing successive changes of variables that eliminate the dependence of the Hamiltonian on the fast phases in the increasingly higher orders in the small parameter. The procedure of successive changes of variables was proposed by Newcomb. Its present form was given by Poincaré, who, however, considered Newcomb’s procedure to be equivalent to that of Lindstedt.

In fact, as was discovered in the works of Kolmogorov [25] and Arnold [6, 7], the procedure of successive changes of variable has the remarkable property of quadratic convergence: after m changes of variables the phase-depending discrepancy in the Hamiltonian is of order ε^{2^m} (disregarding small denominators). Such “superconvergence” neutralizes the influence of small denominators and makes the whole procedure convergent on some “non-resonant” set.

The procedure of successive changes of variables can be realized in different ways. Below we describe Arnold’s construction, which is close to the original method of Newcomb.

Consider a perturbed Hamiltonian system with Hamiltonian

$$H(I, \varphi, \varepsilon) = H_0(I) + \varepsilon H_1(I, \varphi, \varepsilon). \quad (6.43)$$

We perform a symplectic near-identity change of variables $(I, \varphi) \mapsto (J, \psi)$ so that in the new variables the terms of the Hamiltonian of order ε do not depend on the phases. Such a change of variables was already constructed in §6.2.2.A in the consideration of the first approximation for Lindstedt’s method. It is given by the generating function

$$J\varphi + \varepsilon S(J, \varphi), \quad S = -\{H_{1N}(J, \varphi, \varepsilon)\}^\varphi. \quad (6.44)$$

Here $\{\cdot\}^\varphi$ is the integration operator, $H_{1N}(J, \varphi, \varepsilon)$ is the sum of those harmonics of the Fourier series of the function H_1 whose orders do not exceed an integer N . The integer N is chosen so that the absolute value of the remainder $R_{1N} = H_1 - H_{1N}$ of the Fourier series does not exceed ε . The new Hamiltonian $\mathcal{H}(J, \psi, \varepsilon)$ has the form

$$\begin{aligned} \mathcal{H}(J, \psi, \varepsilon) &= \mathcal{H}_0(J, \varepsilon) + \varepsilon^2 \mathcal{H}_1(J, \psi, \varepsilon), \\ \mathcal{H}_0(J, \varepsilon) &= H_0(J) + \varepsilon \langle H_1 \rangle^\varphi, \\ \varepsilon^2 \mathcal{H}_1(J, \psi, \varepsilon) &= \left[H_0 \left(J + \varepsilon \frac{\partial S}{\partial \varphi} \right) - H_0(J) - \varepsilon \frac{\partial H_0}{\partial J} \frac{\partial S}{\partial \varphi} \right] \\ &\quad + \varepsilon \left[H_1 \left(J + \varepsilon \frac{\partial S}{\partial \varphi}, \varphi, \varepsilon \right) - H_1(J, \varphi, \varepsilon) \right] \\ &\quad + \varepsilon R_{1N}(J, \varphi, \varepsilon). \end{aligned} \quad (6.45)$$

On the right-hand side of the last of these equalities, φ must be expressed in terms of ψ , J by the formulae of the change of variables.

The new Hamiltonian has the same form as the old one, but the phases are involved only in terms of order ε^2 . In the resulting system we perform a similar change of variables. After that the phases remain only in terms of order ε^4 (see (6.45)). After m such changes of variables the dependence on the phases remains only in terms of order ε^{2^m} . Recall that in Lindstedt's method after the change of variables of the m th approximation the dependence on the phases remains in terms of the Hamiltonian of order ε^{m+1} .

The estimate ε^{2^m} indicates the formal order in ε of the discrepancy in the Hamiltonian. Actually the discrepancy can be much larger because of the influence of small denominators.

Example 6.19. Consider the first change of variables described above in a domain where the frequencies satisfy the usual incommensurability condition $|(k, \omega(J))| \geq \varkappa |k|^{-\nu}$, $0 \leq |k| \leq N$. Clearly,

$$|I - J| = \left| \varepsilon \frac{\partial S}{\partial \varphi} \right| \sim \frac{\varepsilon}{\varkappa}, \quad |\varphi - \psi| = \left| \varepsilon \frac{\partial S}{\partial J} \right| \sim \frac{\varepsilon}{\varkappa^2}, \quad |\varepsilon^2 \mathcal{H}_1| \sim \frac{\varepsilon^2}{\varkappa^2}.$$

The value of \varkappa can vary from a quantity of order 1 to a quantity of order $\sqrt{\varepsilon}$ (for $\varkappa \sim \sqrt{\varepsilon}$ we have $|\varepsilon \frac{\partial S}{\partial J}| \sim 1$ and the generating function introduced above may not define a one-to-one correspondence $(I, \varphi) \leftrightarrow (J, \psi)$). For $\varkappa \sim \sqrt{\varepsilon}$ we obtain $|\varepsilon^2 \mathcal{H}_1| \sim \varepsilon$ instead of the formal estimate ε^2 . \triangle

We consider the whole sequence of changes of variables on a non-resonant set, where the arising small denominators are estimated from below by quantities $c\sqrt{\varepsilon}|k|^{-\nu}$, where $c = \text{const} > 0$, $\nu = \text{const} > n - 1$, and $|k|$ is the order of the harmonic corresponding to the denominator; the constant c must be chosen to be sufficiently large. It turns out that on this set the fast increase of the order of discrepancies in ε suppresses the influence of small denominators, and the composition of the successive changes of variables converges. This assertion is central in KAM theory. Its consequences are stated in § 6.3.

The procedure of successive changes of variables ensures superconvergence also for those degenerate systems where the degeneracy, as one says, is "removable". This means that the Hamiltonian of the problem has the form

$$H = H_{00}(I) + \varepsilon H_{01}(I) + \varepsilon^2 H_1(I, \varphi, \varepsilon),$$

where H_{00} depends only on $r < n$ action variables, and H_{01} on all the n variables. For the unperturbed Hamiltonian one chooses $H_{00} + \varepsilon H_{01}$. The unperturbed problem has n frequencies, as in the non-degenerate case, but r of them are of order 1, and $n - r$ of order ε . The perturbation is $1/\varepsilon$ times smaller than the minimal frequency. The procedure of successive changes of variables is organized in exactly the same way as in the non-degenerate case. It turns out that it converges on the corresponding non-resonant set [7]. For tutorials on KAM theory, see [183, 392, 512].

Above we were assuming that the perturbation H_1 is an analytic function. If H_1 has finite smoothness, then the procedure of successive changes of variables described above causes “loss of derivatives”: in each approximation the perturbation has fewer derivatives than in the preceding one. Because of this the procedure stops after finitely many steps. For finite smoothness of the perturbation, Moser suggested modifying the procedure using the smoothing technique going back to Nash [446]. It is well known that a smooth function can be approximated with any accuracy by an analytic one; if the function is periodic in some variables, then the approximation can be chosen in the form of a trigonometric polynomial in these variables. Suppose that in the expression for the generating function of the change of variables of the first approximation (6.44), H_{1N} is an analytic function that is a trigonometric polynomial in the phases and approximates H_1 to within ε . Such a change of variables eliminates the phases from the Hamiltonian to within terms of order ε^2 . In the next approximations we proceed in similar fashion. Such a procedure preserves the smoothness of the perturbation. The results of [436, 438] imply that for a sufficiently smooth perturbation the successive approximations converge on a non-resonant set.³¹ After the first results of Moser, the requirements on the smoothness of the perturbation were gradually lowered in the works of Moser, Rüssmann, Pöschel, and Herman. In [439, 508] it was shown that in the non-degenerate case it suffices to require that the perturbation is of class C^r , $r > 2n$ (where r is not necessarily an integer, so that C^r is a Hölder space). For a map of an m -dimensional annulus $B \times \mathbb{T}^m$ (where B is a domain in \mathbb{R}^m) into itself close to an m -dimensional twist rotation³² it suffices to require that the perturbation is of class C^r , $r > 2m + 1$; then the invariant tori of the map fill the annulus to within a remainder of measure which tends to zero as the perturbation magnitude does. (A map of an annulus appears as the Poincaré return map for a Hamiltonian of the form (6.43).) For the case of an annulus map on the plane ($m = 1$), in the original paper of Moser [436] the perturbation was required to be smooth of class C^{333} (see also [441]). Herman’s result [279] for this case: it suffices to require C^3 . For any smoothness C^r , $r < 3$, for each real α there exists an arbitrarily small perturbation for which the perturbed map has no smooth invariant curves that have rotation number α and are non-contractible within the annulus ([278], p. 79). For any smoothness C^r , $r < 2$, there exists an arbitrarily small perturbation for which the perturbed map has no invariant curves that are non-contractible within the annulus ([278], p. 61); first a similar assertion was proved for smoothness C^1 in [577]. In these results on the

³¹ The technique of successive approximations with smoothing also gave rise to new implicit function theorems of the Nash–Moser type [273, 438, 622] in nonlinear functional analysis.

³² A multidimensional twist rotation is a map of the form $(I, \varphi \bmod 2\pi) \mapsto (I, \varphi + h(I) \bmod 2\pi)$, $I \in B \subset \mathbb{R}^m$, $\varphi \bmod 2\pi \in \mathbb{T}^m$, $\det(\partial h / \partial I) \neq 0$.

absence of invariant curves, the perturbation can also be chosen to be smooth of class C^∞ but small in the C^r -topology.

6.3 KAM Theory

KAM theory is the theory of perturbations of conditionally periodic motions of Hamiltonian and related systems in the large for infinite time intervals. In particular, it gives a rigorous justification to the fundamental conclusion about the absence of evolution in such systems which follows from the heuristic averaging principle and formal integration procedures.

6.3.1 Unperturbed Motion. Non-Degeneracy Conditions

We recall the basic concepts relating to integrable systems. We consider an unperturbed integrable Hamiltonian system with Hamiltonian $H_0(I)$. Its phase space is foliated into the invariant tori $I = \text{const}$. The motion on a torus is conditionally periodic with frequency vector $\omega(I) = \partial H_0 / \partial I$. A torus on which the frequencies are rationally independent is said to be *non-resonant*. A trajectory fills such a torus everywhere densely (as one says, it is a winding of the torus). The other tori $I = \text{const}$ are said to be *resonant*. They are foliated into invariant tori of lower dimension. The unperturbed system is said to be *non-degenerate* if its frequencies are functionally independent:

$$\det \left(\frac{\partial \omega}{\partial I} \right) = \det \left(\frac{\partial^2 H_0}{\partial I^2} \right) \neq 0.$$

In a non-degenerate system the non-resonant tori form an everywhere dense set of full measure. The resonant tori form a set of measure zero, which, however, is also everywhere dense. Moreover, the sets of invariant tori with any number of rationally independent frequencies from 1 to $n - 1$ are everywhere dense; in particular, the set of tori on which all trajectories are closed is everywhere dense.

The unperturbed system is said to be *isoenergetically non-degenerate* if one of the frequencies does not vanish and the ratios of the other $n - 1$ frequencies to it are functionally independent on the energy level $H_0 = \text{const}$. The condition of isoenergetic non-degeneracy can be written in the form

$$\det \begin{pmatrix} \frac{\partial \omega}{\partial I} & \omega \\ \omega & 0 \end{pmatrix} = \det \begin{pmatrix} \frac{\partial^2 H_0}{\partial I^2} & \frac{\partial H_0}{\partial I} \\ \frac{\partial H_0}{\partial I} & 0 \end{pmatrix} \neq 0.$$

In an isoenergetically non-degenerate system both the set of non-resonant tori and the set of resonant tori are dense on each energy level; but, as above, the first set has full measure, whereas the second has measure zero.

6.3.2 Invariant Tori of the Perturbed System

We now consider a perturbed system with Hamiltonian

$$H(I, \varphi, \varepsilon) = H_0(I) + \varepsilon H_1(I, \varphi, \varepsilon). \quad (6.46)$$

The theorem of Kolmogorov [25, 6] (extended by Arnold [6]) stated below shows what happens to the non-resonant tori under a perturbation.

Theorem 6.16 (Kolmogorov's theorem). *If the unperturbed Hamiltonian system is non-degenerate or isoenergetically non-degenerate, then under a sufficiently small Hamiltonian perturbation most of the non-resonant invariant tori do not disappear but are only slightly deformed, so that in the phase space of the perturbed system there also exist invariant tori filled everywhere densely with phase curves winding around them conditionally periodically with the number of frequencies equal to the number of degrees of freedom. These invariant tori form a majority in the sense that the measure of the complement of their union is small together with the perturbation. In the case of isoenergetic non-degeneracy the invariant tori form a majority on each energy-level manifold.*

The invariant tori constructed in this theorem are called *Kolmogorov tori*, and their union, the *Kolmogorov set*. The proof of the theorem is based on the converging procedure for eliminating the fast phases (see § 6.2.2.C).

The part of Theorem 6.16 concerning isoenergetic non-degeneracy is in fact due to Arnold [6]. The relations between a persistent non-resonant torus of the unperturbed system and the corresponding invariant torus of the perturbed system are different in the non-degenerate case and in the isoenergetically non-degenerate case.

In the non-degenerate case (the unperturbed frequencies are functionally independent), the frequencies of the unperturbed torus and the perturbed torus are the same.

On the other hand, in the isoenergetically non-degenerate case (the ratios of the unperturbed frequencies are functionally independent on each energy level), the *ratios* of the frequencies of the unperturbed torus and the perturbed torus are the same and, moreover, the *energies* of these tori are the same (that is, the value of H_0 at the unperturbed torus is equal to the value of H at the perturbed torus).

It is important to emphasize that non-degeneracy implies the persistence of most of the unperturbed invariant tori $I = I^0$ with given frequency vectors $\omega(I^0)$ in the whole phase space. It is possible that for each "action" I^0 , among the perturbed tori with the fixed energy value equal to $H_0(I^0)$, there will be no torus with the frequency vector $\omega(I^0)$ and even no torus with a frequency vector proportional to $\omega(I^0)$ – however small the perturbation is.

Example [547]. Assume that the “action” I ranges in a domain G lying in the first coordinate “ 2^n -ant” in \mathbb{R}^n and let

$$H_0(I) = \sum_{i=1}^n a_i \ln I_i,$$

where a_1, \dots, a_n are non-zero constants whose sum is zero. This unperturbed Hamiltonian is non-degenerate but isoenergetically degenerate everywhere in G ; see [17, 46]. The frequencies of a torus $I = I^0$ are $\omega_i(I^0) = a_i/I_i^0$, $1 \leq i \leq n$. Consider the perturbed Hamiltonian $H = H_0(I) + \varepsilon$ with arbitrarily small $\varepsilon \neq 0$. The perturbed system is still integrable and possesses the same invariant tori with the same frequencies. Nevertheless, in the perturbed energy level $H_0(I) + \varepsilon = H_0(I^0)$, there are *no* invariant tori with frequency vectors proportional to $\omega(I^0)$. Indeed, suppose that $\omega(I^1) = c\omega(I^0)$ for some $I^1 \in G$ and $c > 0$. This means that $I_i^1 = I_i^0/c$, $1 \leq i \leq n$, whence

$$H_0(I^1) + \varepsilon = H_0(I^0) - (\ln c) \sum_{i=1}^n a_i + \varepsilon = H_0(I^0) + \varepsilon \neq H_0(I^0).$$

△

On the other hand, isoenergetic non-degeneracy ensures the persistence of the *ratios* of given frequencies $\omega_1(I^0), \dots, \omega_n(I^0)$ for most of the unperturbed invariant tori $I = I^0$ at the fixed energy value. It is possible that for each “action” I^0 , the perturbed system will have no invariant torus with the frequency vector *equal* to $\omega(I^0)$, not merely proportional to $\omega(I^0)$, even if one does not confine oneself to the energy level $H(I, \varphi, \varepsilon) = H_0(I^0)$ – however small the perturbation is.

Example [547]. It is easy to verify that the unperturbed Hamiltonian

$$H_0(I) = I_1 + \frac{1}{2} \sum_{i=2}^n I_i^2$$

is isoenergetically non-degenerate but degenerate everywhere. The frequency vector of a torus $I = I^0$ is $\omega(I^0) = (1, I_2^0, \dots, I_n^0)$. Consider the perturbed Hamiltonian $H_0(I) + \varepsilon I_1$ with arbitrarily small $\varepsilon \neq 0$. Like in the previous example, the perturbed system is still integrable and possesses the same invariant tori $I = I^0$ with the frequency vectors $\omega'(I^0) = (1 + \varepsilon, I_2^0, \dots, I_n^0)$. Clearly, $\omega'(I^1) \neq \omega(I^0)$ for any I^1, I^0 . △

By the way, these examples show that the conditions of non-degeneracy and isoenergetic non-degeneracy are independent.

One can make several additions to the general formulation of Kolmogorov’s theorem.

1°. The theorem holds if both the unperturbed Hamiltonian and the perturbation are of class C^r , $r > 2n$ [508, 533]. (In the original formulations

the unperturbed Hamiltonian and the perturbation were assumed to be analytic [6].) In what follows, the unperturbed Hamiltonian is assumed to be analytic; this simplifies the statements and, besides, many further results have been obtained under this assumption. The perturbation is also assumed to be analytic, unless stated otherwise.

2°. Let the unperturbed system be non-degenerate and suppose that we are given a number ν satisfying the inequalities $n - 1 < \nu < \frac{1}{2}r - 1$. Under a sufficiently small perturbation of class C^r the frequency vectors of the motions on the Kolmogorov tori belong to the Cantor set

$$\Xi_\varkappa = \{ \xi : \xi \in \Xi \subset \mathbb{R}^n, |(k, \xi)| > \varkappa |k|^{-\nu} \ \forall k \in \mathbb{Z}^n \setminus \{0\} \},$$

where Ξ is the set of the unperturbed frequency vectors $\omega(I)$ and \varkappa is a quantity of order $\sqrt{\varepsilon}$; see [509]. Recall that the Lebesgue measure of the complement of Ξ_\varkappa in Ξ does not exceed a quantity of order \varkappa . An analogous statement is valid in the isoenergetically non-degenerate case. In the latter case, the frequency vectors of the motions on the Kolmogorov tori also satisfy the strong incommensurability condition with constants $\nu > n - 1$ and $\varkappa \sim \sqrt{\varepsilon}$.

3°. The measure of the complement of the Kolmogorov set does not exceed a quantity of order $\sqrt{\varepsilon}$. The deformation of a persistent torus, that is, its deviation from the unperturbed torus with the same frequencies or frequency ratios of the conditionally periodic motion depends on the arithmetic properties of the frequencies. If the frequency vector in the non-degenerate case belongs to Ξ_δ , $\delta > \varkappa$ (see 2°), then the deformation does not exceed a quantity of order $\varepsilon/\delta \lesssim \sqrt{\varepsilon}$ [369, 454, 509, 570]. An analogous statement holds in the isoenergetically non-degenerate case.

4°. The Kolmogorov tori form a smooth family [369, 509, 570]. We formulate this assertion in more detail. First we consider the non-degenerate case. For simplicity we assume that the frequency map $I \mapsto \omega(I)$ is a diffeomorphism. Then for perturbations of class C^r , $r > 3\nu + 2 > 3n - 1$, there exists a diffeomorphism

$$\Psi: \Xi\{\xi\} \times \mathbb{T}^n\{\vartheta\} \rightarrow \mathbb{R}^n\{I\} \times \mathbb{T}^n\{\varphi\}$$

whose restriction to the Cantor set of standard tori $\Xi_\varkappa \times \mathbb{T}^n$ maps it into the Kolmogorov set. In the variables ξ, ϑ for $\xi \in \Xi_\varkappa$ the equations of motion take the form

$$\dot{\xi} = 0, \quad \dot{\vartheta} = \xi.$$

The diffeomorphism Ψ has anisotropic smoothness: the number of its derivatives with respect to the phase ϑ is greater than with respect to the frequency ξ . The smoothness with respect to ϑ is the smoothness of an individual invariant torus, whereas the smoothness with respect to ξ is the smoothness proper of the family of tori.

The order of smoothness of the diffeomorphism Ψ can be estimated from below in terms of the order of smoothness of the perturbation. In particular, if

the perturbation is analytic, then Ψ is analytic with respect to ϑ (that is, each torus is analytic) and infinitely differentiable with respect to ξ (that is, the tori form an infinitely differentiable family). Note that if Ψ were analytic with respect to all the variables, then the perturbed system would be completely integrable (whereas a typical system is non-integrable; see Ch. 7).

In fact, if the perturbation is analytic or Gevrey smooth, then the diffeomorphism Ψ is Gevrey smooth with respect to ξ (rather than just infinitely differentiable), see [504, 505, 602] (and a discussion in [546]) for the case of analytic H_1 , and [506, 507] for the case of Gevrey smooth H_1 .

In the case of isoenergetic non-degeneracy the family of tori on each energy level is similarly smoothly parametrized by the ratios of the frequencies (and smoothly depends on the energy).

5°. The perturbed system is completely integrable on the Cantor set [509]. In the non-degenerate case, this means that for a sufficiently smooth perturbation there exist a symplectic change of variables $I, \varphi \mapsto J, \psi$ with generating function $J\varphi + \varepsilon S(J, \varphi, \varepsilon)$ and a non-degenerate Hamiltonian $\mathcal{H}(J, \varepsilon)$ such that

$$H_0\left(J + \varepsilon \frac{\partial S}{\partial \varphi}\right) + \varepsilon H_1\left(J + \varepsilon \frac{\partial S}{\partial \varphi}, \varphi, \varepsilon\right) \Big|_{B_{\varkappa, \varepsilon} \times \mathbb{T}^n} = \mathcal{H}(J, \varepsilon) \Big|_{B_{\varkappa, \varepsilon}}$$

and this equality can be differentiated sufficiently many times. Here $B_{\varkappa, \varepsilon}$ is the inverse image of the standard Cantor set Ξ_\varkappa (see 2°) under the map $J \mapsto \partial \mathcal{H} / \partial J$. In the isoenergetically non-degenerate case the statement is analogous. The functions S, \mathcal{H} are obtained from the corresponding functions given by the procedure of § 6.2.2.C by smoothing in the “gaps” between the Kolmogorov tori.

6°. There is an interpretation of the conditions of non-degeneracy and isoenergetic non-degeneracy in terms of Lie algebras of symmetries of the unperturbed system [118, 119].

7°. The condition of non-degeneracy (isoenergetic non-degeneracy) in Kolmogorov’s theorem can be considerably weakened. Namely, it suffices to require the so-called *non-degeneracy in the sense of Rüssmann*: for some $N > 0$ the linear span of the system of vectors

$$D^q \omega(I) = \frac{\partial^{|q|} \omega(I)}{\partial I_1^{q_1} \dots \partial I_n^{q_n}}, \quad q = (q_1, \dots, q_n) \in \mathbb{Z}_+^n, \quad |q| = q_1 + \dots + q_n \leq N,$$

coincides with the whole space \mathbb{R}^n for each $I = (I_1, \dots, I_n)$. This condition was introduced and used in the problem of averaging non-Hamiltonian perturbations by Bakhtin [96], whose paper was preceded by the works of Sprindzhuk [567] and Pyartli [516] on the theory of Diophantine approximations on submanifolds of a Euclidean space. The condition is indeed extremely weak: for any n there exist Rüssmann non-degenerate Hamiltonians $H_0(I)$ such that the image of the frequency map $I \mapsto \omega(I)$ is a one-dimensional curve in \mathbb{R}^n [17, 540, 542, 546]. An analogue of Theorem 6.16 for

Rüssmann non-degenerate unperturbed Hamiltonians was obtained independently by Rüssmann [527, 528] (see also [529]), Herman (unpublished), Cheng and Sun [174], and Sevryuk [540, 542] (see also the references in [17, 546]). The proofs in these works are based on different ideas. For analytic Hamiltonians H_0 (non-analytic Hamiltonians are not considered here anyway) and connected domain of definition of the variables I , the Rüssmann non-degeneracy condition is equivalent to the following: the image of the frequency map $I \mapsto \omega(I)$ is not contained in any hyperplane passing through the origin. The last condition is *necessary* for the existence of invariant tori in (any) perturbed system: if the image of the frequency map of a completely integrable Hamiltonian is contained in some hyperplane passing through the origin, then by an arbitrarily small perturbation one can obtain a Hamiltonian system that does not have a single invariant torus of the form $I = f(\varphi)$, nor even one on which the motion is not conditionally periodic [17, 540].

In the case of Rüssmann non-degeneracy it is impossible to determine a priori the set of frequency vectors of the motion on the invariant tori of the perturbed system. This set depends on the perturbation. Moreover, the set of frequency ratios of the perturbed tori can be disjoint from the set of frequency ratios of the unperturbed tori [546]. Therefore in the analogue of Theorem 6.16 for Rüssmann non-degenerate unperturbed Hamiltonians one speaks not about the persistence of the non-resonant unperturbed invariant tori, but only about the existence of invariant tori for the perturbed Hamiltonian.

Nevertheless additions 1°–4° to Theorem 6.16 can be carried over *mutatis mutandis* to the case of Rüssmann non-degenerate Hamiltonians $H_0(I)$ – with different estimates of the smoothness and of the measure of the complement of the union of invariant tori. For example, the measure of the complement of the union of invariant tori of the perturbed system is a quantity of order not $\leq \sqrt{\varepsilon}$, but $\leq \varepsilon^{1/(2N)}$, where N is the number involved in the definition of Rüssmann non-degeneracy [540]. All the non-degenerate and isoenergetically non-degenerate Hamiltonians are non-degenerate in the sense of Rüssmann with $N = 1$. An analogue of addition 4° for Rüssmann non-degenerate Hamiltonians is stated in § 6.3.7 below in a more general situation (for the so-called lower-dimensional tori).

Recently, there were introduced and examined non-degeneracy conditions that are intermediate between the usual non-degeneracy (isoenergetic non-degeneracy) and the non-degeneracy in the sense of Rüssmann [190]. For similar conditions in the case of lower-dimensional tori, see [380, 390, 547].

There often occurs the case of *proper degeneracy* where the unperturbed Hamiltonian is independent of some of the action variables. We say that a perturbation removes the degeneracy if the perturbed Hamiltonian can be reduced to the form

$$H = H_{00}(I) + \varepsilon H_{01}(I) + \varepsilon^2 H_{11}(I, \varphi, \varepsilon), \quad (6.47)$$

where H_{00} depends only on the first r action variables and is either non-degenerate or isoenergetically non-degenerate with respect to these variables, while H_{01} depends, generally speaking, on all the “actions” and is non-degenerate with respect to the last $n - r$ of them (the Hessian of H_{01} with respect to I_{r+1}, \dots, I_n is non-zero). We call the system with Hamiltonian $H_{00} + \varepsilon H_{01}$ the intermediate system.

Theorem 6.17 ([7]). *Suppose that the unperturbed system is degenerate, but the perturbation removes the degeneracy. Then a larger part of the phase space is filled with invariant tori that are close to the invariant tori $I = \text{const}$ of the intermediate system. The phase curves wind around these tori conditionally periodically with the number of frequencies equal to the number of degrees of freedom. Among these frequencies, r correspond to the fast phases, and $n - r$ to the slow phases. If the unperturbed Hamiltonian is isoenergetically non-degenerate with respect to those r variables on which it depends, then the invariant tori just described form a majority on each energy-level manifold of the perturbed system.*

Remark 6.15. In many problems the perturbation depends periodically on time: $H = H_0(I) + \varepsilon H_1(I, \varphi, t, \varepsilon)$. This case can be reduced to the autonomous case by introducing time as a new phase. If $\det(\partial^2 H_0 / \partial I^2) \neq 0$, then the system thus obtained is isoenergetically non-degenerate and by Theorem 6.16 it has many $(n + 1)$ -dimensional invariant tori. If such a system is properly degenerate but the perturbation removes the degeneracy, then the invariant tori are provided by Theorem 6.17.

In [35, 437] Moser developed a theory of perturbations of conditionally periodic motions of non-Hamiltonian systems. In particular, it was proved that the invariant tori are preserved in reversible systems. At present the KAM theory for reversible systems has turned into a theory that enjoys practically equal rights with the KAM theory for Hamiltonian systems; there exist analogues of KAM theory for volume preserving and dissipative systems; see [17, 43, 77, 91, 145, 146, 147, 541, 545, 547] and the references therein.

6.3.3 Systems with Two Degrees of Freedom

A. Absence of Evolution

In systems with two degrees of freedom the existence of a large number of invariant tori implies the absence of evolution for all (and not just for most) initial conditions.

Theorem 6.18 ([6]). *In an isoenergetically non-degenerate system with two degrees of freedom, for all initial conditions the action variables remain forever near their initial values.*

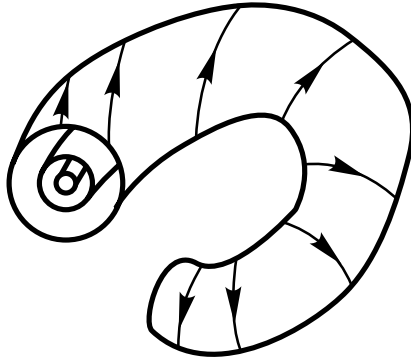

Fig. 6.26.

◁ In the system under consideration the phase space is four-dimensional, the energy levels are three-dimensional, and the Kolmogorov tori are two-dimensional and fill a larger part of each energy level. A two-dimensional torus divides a three-dimensional energy level (Fig. 6.26 shows the disposition of tori within an energy level). A phase curve starting in a gap between two invariant tori of the perturbed system remains forever trapped between these tori. The corresponding action variables remain forever near their initial values. Oscillations of the action variables do not exceed a quantity of order $\sqrt{\varepsilon}$, since the measure of the gap and the deviation of a torus from the unperturbed one ($I = \text{const}$) are estimated by quantities of this order. ▷

An assertion similar to Theorem 6.18 is valid if the system has one and a half degrees of freedom, that is, a perturbation depending periodically on time is imposed on a system with one degree of freedom. The required non-degeneracy condition is $d^2H_0/dI^2 \neq 0$.

If a system with two degrees of freedom is non-degenerate, but is not isoenergetically non-degenerate, then the action variables can sometimes evolve outside the invariant tori.

Example 6.20 ([40]). The system with Hamiltonian $H = (I_1^2 - I_2^2)/2 + \varepsilon \sin(\varphi_1 - \varphi_2)$ has the “fast” solution $I_1 = -\varepsilon t$, $I_2 = \varepsilon t$, $\varphi_1 = -\varepsilon t^2/2$, $\varphi_2 = -\varepsilon t^2/2$. The reason is that on the unperturbed energy level there lies the ray $I_1 = -I_2$, along which the frequency ratio remains constant and equal to 1. It is this ray that is a “superconductivity channel”. △

B. The Case of Proper Degeneracy

Evolution is also absent in the case of *proper degeneracy* if the perturbation removes the degeneracy and there are many invariant tori on the energy level.

For a Hamiltonian of the form (6.47) the corresponding condition of removing the degeneracy can be written as

$$\frac{dH_{00}}{dI_1} \neq 0, \quad \frac{\partial^2 H_{01}}{\partial I_2^2} \neq 0, \tag{6.48}$$

where I_1 and I_2 are the two action variables in the problem.

Theorem 6.19 ([7]). *If a system with two degrees of freedom in the case of proper degeneracy satisfies conditions (6.48), then for all initial data the action variables remain forever near their initial values.*

A degenerate system with two degrees of freedom is “more integrable” than a usual perturbed system in the following sense.

Theorem 6.20 ([454]). *Suppose that a degenerate system (6.47) satisfies conditions (6.48) and, in addition, the condition $\partial H_{01}/\partial I_2 \neq 0$ (which means that the “slow” frequency does not vanish). Then the measure of the set of tori disappearing under the perturbation is exponentially small ($O(\exp(-\text{const}/\varepsilon))$) instead of $O(\sqrt{\varepsilon})$ in the non-degenerate case) and the deviation of a torus from $I = \text{const}$ is of order ε .*

◁ The cause of this phenomenon is that the “fast” and “slow” frequencies differ by a factor of $1/\varepsilon$, and corresponding to a resonance between them there are harmonics of the perturbation that have high order $1/\varepsilon$ and, accordingly, small amplitude $O(\exp(-\text{const}/\varepsilon))$. ▷

Remark 6.16. Analogous assertions are valid if a system has one and a half degrees of freedom. In the case of proper degeneracy for one and a half degrees of freedom the Hamiltonian has the form

$$H = \varepsilon H_{01}(I) + \varepsilon^2 H_{11}(I, \varphi, t, \varepsilon). \tag{6.49}$$

The condition of removing the degeneracy is $d^2 H_{01}/dI^2 \neq 0$. The measure of the tori that are destroyed is exponentially small if, in addition, $dH_{01}/dI \neq 0$.

Systems with proper degeneracy describe, in particular, the motion in Hamiltonian systems with two degrees of freedom if one degree of freedom is fast and the other is slow (see § 6.4), and in Hamiltonian systems with one and a half degrees of freedom if the dependence of the Hamiltonian on time is fast periodic. We now consider the latter case in more detail. The Hamiltonian has the form

$$H = E(p, q) + E_1(p, q, t/\varepsilon, \varepsilon), \tag{6.50}$$

where p, q are conjugate canonical variables, the Hamiltonian is 2π -periodic in $\bar{t} = t/\varepsilon$, $E_1 = E_{10}(p, q, \bar{t}) + O(\varepsilon)$, and $\langle E_{10} \rangle^{\bar{t}} = 0$. By introducing \bar{t} as the new time (we will not write the bar over t in what follows) we obtain the system with Hamiltonian εH in which the variables p, q are slow and the

variable t is fast. One step of the procedure for eliminating the fast variables in §6.2.2.B reduces the Hamiltonian to the form $\varepsilon E(P, Q) + \varepsilon^2 \mathcal{H}_1(P, Q, t, \varepsilon)$, where P, Q are the new canonical variables. By discarding the term of order ε^2 in the Hamiltonian we obtain that the motion is approximately described by the Hamiltonian system with one degree of freedom and with Hamiltonian $\varepsilon E(P, Q)$. For example, suppose that the phase portrait of this system has the form shown in Fig. 6.27a (in this case it is assumed that P, Q are coordinates on a cylinder). This portrait can be regarded as the section of the phase space P, Q, t of the averaged system by the plane $t = 0$. Corresponding to the equilibria in Fig. 6.27a we have periodic solutions; to the separatrices, surfaces asymptotic to these solutions as $t \rightarrow \pm\infty$ (they are also called separatrices); and to the closed curves, two-dimensional invariant tori.



Fig. 6.27.

One can make this picture slightly more precise by performing several steps of the procedure for eliminating the fast variable (§6.2.2) and discarding the additional terms of higher order of smallness arising in the Hamiltonian. This again results in a system with one degree of freedom whose phase portrait is close to the portrait in Fig. 6.27a.

How will the discarded small terms affect the motion? The periodic solutions are preserved (this follows from the implicit function theorem). The surfaces asymptotic to them are also preserved. But the surfaces that are asymptotic as $t \rightarrow +\infty$ and $t \rightarrow -\infty$ to different solutions (or even to one solution) no longer have to coincide with each other (see Fig. 6.27b, which shows the section of the phase space by the plane $t = 0$). This is the phenomenon of *splitting of separatrices* discovered by Poincaré [41].

The question of the fate of invariant tori is answered by Theorems 6.17 and 6.20. In each of the domains filled by closed trajectories in Fig. 6.27a one can introduce the action–angle variables I, φ of the averaged Hamiltonian \mathcal{H} . In these variables, far from the separatrices the full Hamiltonian takes the form (6.49), which is standard for a Hamiltonian with a removable proper degeneracy. Therefore far from the separatrices there are all the tori found in the averaging except for a proportion $O(\exp(-c^{-1}/\varepsilon))$, $c = \text{const} > 0$. In a vicinity of the separatrices a special analysis is required, which shows

that there are tori that are exponentially close to the separatrices, so that the separatrices are locked in an exponentially narrow zone [455].

The magnitude of the splitting of separatrices can be characterized by the angle α between them at some intersection point far from the saddles, or by the area A of the domain (lobe) bounded by pieces of the separatrices between the neighbouring intersection points (Fig. 6.27*b*), or by the width d of this lobe. All these quantities are exponentially small (since the system can be reduced by a symplectic change of variables to an autonomous Hamiltonian system with an accuracy $O(\exp(-\text{const}/\varepsilon))$, see § 6.1.4). In the case of a transversal intersection ($\alpha \neq 0$) we have $A \sim \varepsilon^2 \alpha$ and $d \sim \varepsilon \alpha$.

The width of the zone between invariant tori in which the separatrices are locked is estimated from above by a quantity of order d/ε (the width can be defined, for example, as the distance between the invariant tori along a vertical line in Fig. 6.27*b* far from the saddles) [48, 372].

The asymptotics of the exponentially small quantities α , A , d was for the first time calculated by Lazutkin [371] for the model problem of the splitting of separatrices of the Chirikov standard map [189]. This is a symplectic map $(P, q \bmod 2\pi) \mapsto (P', q' \bmod 2\pi)$ defined by the formulae

$$P' = P + \mu \sin q, \quad q' = q + P'. \quad (6.51)$$

After the normalization $P = \varepsilon p$, $\varepsilon = \sqrt{\mu}$ the map takes the form

$$p' = p + \varepsilon \sin q, \quad q' = q + \varepsilon p'$$

and can be regarded as the shift map by time $2\pi\varepsilon$ for the Hamiltonian system with impacts having the Hamiltonian

$$H = \frac{1}{4\pi} p^2 + \cos q \sum_{k \in \mathbb{Z}} \delta\left(\frac{t}{\varepsilon} + 2\pi k\right) = \frac{1}{2\pi} \left(\frac{p^2}{2} + \cos q \sum_{n \in \mathbb{Z}} e^{int/\varepsilon} \right), \quad (6.52)$$

where $\delta(\cdot)$ is Dirac's δ -function. Thus, the Hamiltonian has the form (6.50), but H in this expression is a generalized function (a distribution). The corresponding averaged system is the pendulum with the Hamiltonian

$$E = \frac{1}{2\pi} \left(\frac{p^2}{2} + \cos q \right). \quad (6.53)$$

Lazutkin's formula for the area A_c of the lobe formed at the splitting of the separatrices of this pendulum under the influence of the perturbations in (6.52) is as follows (the area is calculated in the original variables P , q):

$$A_c = \frac{2|\theta_1|}{\pi} e^{-\pi^2/\sqrt{\mu}} (1 + O(\mu)), \quad (6.54)$$

where $|\theta_1| = 1118.8277\dots$ is a constant determined from the solution of an auxiliary problem that does not involve a small parameter (the constant θ_1

was calculated in [373]). In terms of the original map (6.51), A_c is the area of the lobe formed by the intersections of the invariant curves of the map (6.51) that are homoclinic to the fixed point ($q = 0 \pmod{2\pi}$, $P = 0$).

The approach of [371] is based on constructing a natural parametrization of invariant homoclinic curves and studying the complex singularities of this parametrization. This approach has allowed one to calculate the asymptotics of the splitting of separatrices for a number of other symplectic near-identity maps (see, for example, [252]). A complete proof of formula (6.54) was given in [248]. The term $O(\mu)$ in (6.54) admits asymptotic expansion in powers of μ [251]; several first terms of this expansion were calculated in [251].

For analytic Hamiltonian systems with fast periodic dependence of the Hamiltonian on time, the asymptotic behaviour of the size of the splitting of separatrices was first calculated under the (very restrictive) assumption that

$$|E_1| \lesssim \varepsilon^p, \quad p > 1,$$

in the Hamiltonian (6.50) (an assumption used by Poincaré [41], who treated the case $E_1 \sim \exp(-\text{const}/\varepsilon)$; later the admissible values of p were gradually lowered; see, for example, [205, 228, 286]). The asymptotics of the splitting of separatrices for $E_1 \sim 1$ was first calculated by Treshchev ([585], see also [587, 588]) using the method of continuous averaging (see § 6.1.2, Remark 6.3) for the problem of the motion of a pendulum with a rapidly oscillating point of suspension. A close result was obtained by Gelfreich ([246], see also [247, 249]), whose arguments were based on the approach of [371]. The Hamiltonian of the problem of a pendulum with an oscillating point of suspension has the form (6.50) with

$$\begin{aligned} E &= \frac{p^2}{2} - \cos q, & E_1 &= e^{it/\varepsilon} E^+(p, q) + e^{-it/\varepsilon} E^-(p, q), \\ E^\pm &= B_\pm^\pm e^{iq} + B_\mp^\pm e^{-iq}, & \bar{B}_+^+ &= B_-^-, & \bar{B}_-^+ &= B_+^- \end{aligned} \tag{6.55}$$

(the bar denotes complex conjugation). The phase portrait of the averaged system is as in Fig. 6.27*a*. It was shown in [585, 588] that the area A_p of the lobe shaded in Fig. 6.27*b* is given by the formula

$$A_p = 16\pi\varepsilon^{-1} \exp\left(-\frac{\pi\varepsilon^{-1}}{2}\right) [|B_-^+ j(4B_-^+ B_-^-)| + O(\varepsilon \ln \varepsilon)], \tag{6.56}$$

where $j(\cdot)$ is an entire real-analytic function, $j(0) = 2$, and $j'(0) = 0.658567\dots$. This function is obtained as the solution of a certain problem that does not involve a small parameter. The approach of [585, 588] is as follows. First the method of continuous averaging is used to reduce the Hamiltonian to the form (6.50) with $E = E(p, q, \varepsilon)$, $|E_1| \lesssim \exp(-c/\varepsilon)$; in the case of a pendulum, $c = \pi/2 - \varkappa$, where \varkappa is any prescribed positive constant. One then applies to the system obtained the Poincaré–Mel’nikov approach (§ 7.2.1), which enables one to express the asymptotics of the splitting of separatrices in terms of the

integral of the perturbation along the unperturbed separatrix in the case of a sufficiently small perturbation.

Formula (6.56) can also be obtained via the approach of continuous averaging [587].

The area S of the zone between invariant tori in which the separatrices are locked can be fairly accurately estimated [48]. Under certain additional symmetry conditions (which hold, in particular, for the standard map (6.51) and for the pendulum (6.55)) there exists the limit

$$\lim_{\varepsilon \rightarrow 0} \frac{S\lambda^2\varepsilon^2}{A \ln A^{-1}} = \frac{2}{k_0},$$

where λ is the eigenvalue of the Hamiltonian E at the saddle point and $k_0 = 0.971653\dots$. In the general (non-symmetric) case the ratio $S\lambda^2\varepsilon^2/(A \ln A^{-1})$ has no limit as $\varepsilon \rightarrow 0$, but oscillates between two constants.

A detailed survey of the results relating to the exponentially small splitting of separatrices is contained in [48, 250].

C. Gaps between Kolmogorov Tori

We now describe the structure of the gap between Kolmogorov tori that appears near a given resonance. For simplicity we consider the case of one and a half degrees of freedom. Let I_r be a resonant value of the “action”: $k_1\omega(I_r) + k_2 = 0$. Let $p = (I - I_r)/\sqrt{\varepsilon}$ and $q = \varphi + (k_2/k_1)t$; for $p = O(1)$ we obtain a Hamiltonian system with proper degeneracy and with Hamiltonian of the form (6.50), but with ε replaced by $\sqrt{\varepsilon}$. The phase portrait of the corresponding averaged system is generically similar to the portrait of a pendulum (see § 6.2.1 and Fig. 6.27*a*). The section of the phase space of the full system by the plane $t = 0$ has the form of Fig. 6.27*b*. Corresponding to the singular points in Fig. 6.27*b* there are the periodic solutions found by Poincaré. The separatrices of unstable periodic solutions are split. (It was for the separatrices of resonant periodic solutions that the problem of splitting of separatrices was for the first time considered by Poincaré.) In accordance with what was said in § 6.3.3.B, a neighbourhood of the resonance of size $\sim \sqrt{\varepsilon}$ is filled with invariant tori up to the remainder of measure $O(\exp(-\text{const}/\sqrt{\varepsilon}))$.

On receding from the resonance the tori found above turn into usual Kolmogorov tori.

Remark 6.17. It is natural to expect that in a generic (analytic) system with two degrees of freedom and with frequencies that do not vanish simultaneously the total measure of the “non-torus” set corresponding to all the resonances is exponentially small. However, this has not been proved.

Remark 6.18. It is natural to expect that in a generic system with three or more degrees of freedom the measure of the “non-torus” set has order ε . Indeed, the $O(\sqrt{\varepsilon})$ -neighbourhoods of two resonant surfaces intersect in a

domain of measure $\sim \varepsilon$. In this domain, after the partial averaging taking into account the resonances under consideration, normalizing the deviations of the “actions” from the resonant values by the quantity $\sqrt{\varepsilon}$, normalizing time, and discarding the terms of higher order, we obtain a Hamiltonian of the form $1/2(Ap, p) + V(q_1, q_2)$, which does not involve a small parameter (see the definition of the quantity p above). Generally speaking, for this Hamiltonian there is a set of measure ~ 1 that does not contain points of invariant tori. Returning to the original variables we obtain a “non-torus” set of measure $\sim \varepsilon$.

Remark 6.19. In a system with three degrees of freedom, for a simple proper degeneracy in the case where the perturbation removes the degeneracy, the measure of the “non-torus” set is estimated from above by a quantity of order $\sqrt{\varepsilon}$. This estimate seems to be best possible. The reason is that in the $O(\sqrt{\varepsilon})$ -neighbourhood of the resonant surface, after partial averaging taking into account the resonance, normalizing the deviation of the “action” from the resonant value by the quantity $\sqrt{\varepsilon}$, normalizing time, and discarding the terms of higher order we obtain a system with Hamiltonian of the form $\alpha p^2/2 + V(q, y, x)$ with respect to the symplectic structure $dp \wedge dq + d(y/\mu) \wedge dx$, where $\mu = \sqrt{\varepsilon}$, $\alpha = \text{const}$. In this system, p, q are the fast variables (the rate of their change is ~ 1), while y, x are the slow variables (the rate of change is $\sim \mu$). Such systems are studied in the theory of adiabatic invariants (§6.4). For any fixed values of the slow variables there is a separatrix on the phase portrait of the fast motion. Generically, the projection of the phase point onto the cylinder of the fast variables repeatedly intersects this separatrix. As discussed in §6.4.7.B, numerical experiments provide convincing evidence that in this system the measure of the “non-torus” set is of order 1. Returning to the original variables we obtain a “non-torus” set of measure of order $\sqrt{\varepsilon}$. The situation just considered arises, in particular, in the spatial restricted circular three-body problem and in the planar restricted elliptic three-body problem with a small mass of the perturbing body (Jupiter) [604], and in the problem of rapid rotation of a rigid body in a potential field [102].

6.3.4 Diffusion of Slow Variables in Multidimensional Systems and its Exponential Estimate

In the study of the perturbed motion outside the invariant tori one should distinguish the cases of two and of a higher number of degrees of freedom.

In the case of two degrees of freedom the invariant two-dimensional tori divide a three-dimensional energy level. This implies that evolution is impossible (§6.3.3.A).

However, if the number of degrees of freedom n is greater than two, then the n -dimensional invariant tori do not divide a $(2n - 1)$ -dimensional energy-level manifold, but are situated in it similar to points on a plane or lines in a space. In this case the “gaps” corresponding to different resonances are con-

nected with each other. Therefore the invariant tori do not prevent a phase curve originated near a resonance going far away.

Conjecture ([7]). *The typical case in a multidimensional problem is topological instability: through an arbitrarily small neighbourhood of any point there passes a phase trajectory along which the slow variables go away from the initial values by a quantity of order 1.*

KAM theory proves metric stability,³³ that is, stability for the most of initial data. Thus, according to the conjecture stated above the typical case in a multidimensional problem is the combination of metric stability and topological instability.

There are several examples of evolution of the slow variables in metrically stable problems. Most of these examples relate to very degenerate situations where the unperturbed Hamiltonian is not a steep function (see the definition of steep functions below). An example of evolution in a system with a steep unperturbed Hamiltonian was constructed in [8]. The average rate of evolution in this example is exponentially small ($O(\exp(-c/\sqrt{\varepsilon}))$).

Example 6.21 ([8]). Consider the system whose Hamiltonian function $H = H_0 + \varepsilon H_1$ depends on two small parameters ε and μ , where

$$H_0 = \frac{1}{2} (I_1^2 + I_2^2), \quad H_1 = (\cos \varphi_1 - 1)(1 + \mu \sin \varphi_2 + \mu \cos t). \quad (6.57)$$

A characteristic feature of this system is the presence of the one-parameter family of two-dimensional invariant tori

$$\mathbb{T}_\omega = \{(I, \varphi \bmod 2\pi, t \bmod 2\pi) : I_1 = 0, \varphi_1 = 0, I_2 = \omega\}.$$

For $\varepsilon > 0$ and small μ the tori \mathbb{T}_ω are hyperbolic. Let Γ_ω^s and Γ_ω^u be the stable and unstable three-dimensional asymptotic manifolds of the torus \mathbb{T}_ω , respectively.

We call a sequence of tori $\mathbb{T}_{\omega_1}, \dots, \mathbb{T}_{\omega_N}$ a *transition chain* if for every $j = 1, \dots, N - 1$ the frequency ω_j is irrational (the torus \mathbb{T}_{ω_j} is non-resonant) and the surfaces $\Gamma_{\omega_j}^u$ and $\Gamma_{\omega_{j+1}}^s$ intersect transversally along some doubly asymptotic solution.³⁴

The following property of a non-resonant hyperbolic torus is intuitively obvious. Let $g^r : \mathbb{R}^2 \times \mathbb{T}^3 \rightarrow \mathbb{R}^2 \times \mathbb{T}^3$ be the phase flow of the system, W a neighbourhood of some point in $\Gamma_{\omega_j}^s$, and Σ a manifold transversal to $\Gamma_{\omega_j}^u$ such that $\Gamma_{\omega_j}^u \cap \Sigma \neq \emptyset$. Then for some $r > 0$ the sets $g^r(W)$ and Σ intersect.³⁵

³³ This word is used here not in the formal sense but as a synonym of the absence of evolution: $\sup_{-\infty < t < \infty} |I(t) - I(0)| \rightarrow 0$ as $\varepsilon \rightarrow 0$.

³⁴ In [8] the definition of a transition chain requires a weaker property.

³⁵ In the theory of hyperbolic systems a similar assertion is called the λ -lemma.

It follows from this property that the presence of a transition chain implies the existence of a trajectory going from an arbitrarily small neighbourhood of the torus \mathbb{T}_{ω_1} into an arbitrarily small neighbourhood of the torus \mathbb{T}_{ω_N} .

Indeed, let W be a neighbourhood of some point of the manifold Γ_1^s . Then for some $r = r_1$ the open set $g^{r_1}(W)$ intersects $\Sigma = \Gamma_2^s$. Similarly, for some $r = r_2$ the set $g^{r_2+r_1}(W)$ intersects Γ_3^s , and so on.

In [8] it was shown that for any positive $A < B$ for arbitrarily small $\varepsilon > 0$ and $\mu = \mu(\varepsilon)$ there exists a transition chain in which $\omega_1 < A$ and $\omega_N > B$. In the proof one has to take μ to be exponentially small compared to ε . \triangle

The evolutionary trajectories in Example 6.21 were constructed by Bessi [109] using variational methods. He obtained the upper estimate $\mu^{-1}e^{-c/\sqrt{\varepsilon}}$ for the time over which the slow variable gains an increment of order 1. This estimate coincides with the lower estimate obtained by Nekhoroshev’s method (see below). The proof is based on the fact that the homoclinic trajectories of an invariant torus \mathbb{T}_ω are minimum points of the Hamiltonian action functional. The evolutionary trajectories of the perturbed system are sought as local minimum points of the action functional on the set of curves close to a chain of homoclinic trajectories. Apparently, the applicability of Bessi’s method is restricted to the case where the perturbed system has a smooth family of invariant tori.

Generalizations of Example 6.21 were recently considered in a large number of papers; see, for example, [186, 109]. But so far there is no method for establishing the existence (or non-existence) of evolution of the slow variables in perturbed analytic systems of sufficiently general form.

The main difficulties arising in construction of transition chains of Example 6.21 in the general case are of two kinds. The first difficulty (the so-called “large gap problem”) is related to the discontinuity of the set of hyperbolic tori: one must make sure that the consecutive tori in the chain are not too far from one another and the manifold Γ_j^u can “reach” Γ_{j+1}^s .

Recently Xia [606] developed a method allowing one to circumvent this difficulty. The point is that, although the set of hyperbolic tori of the perturbed system in the general case is discontinuous (it is a Cantor set), in the gaps there are invariant sets of more complex structure – Mather’s sets. For these sets one can prove the existence of homoclinic trajectories [127]. Xia constructs evolutionary trajectories close to a chain of homoclinic trajectories of Mather’s sets using a method that is a generalization of the method of the Peierls barrier developed by Mather in the theory of twist maps. The applicability of Xia’s method is restricted to the case where Mather’s sets belong to a three-dimensional invariant hyperbolic manifold, on which the usual Aubry–Mather theory can be applied (cf. § 6.3.8). For other results in this direction, see [204, 257, 418].

The second difficulty is caused by exponentially small effects: the intersection angle of the manifolds Γ_j^u and Γ_{j+1}^s is of order $e^{-c/\sqrt{\varepsilon}}$ (in Example 6.21, of order $\mu e^{-c/\sqrt{\varepsilon}}$). Unfortunately, the methods for studying exponentially small

effects in multi-frequency systems are still in an embryonic state. Note that in the system with Hamiltonian (6.57) the first difficulty does not exist, and the second can be avoided by choosing μ of order $e^{-c/\sqrt{\varepsilon}}$.

There is also a difficult problem of obtaining a lower estimate for the rate of evolution of the slow variables along an already given transition chain. This problem was considered in [109, 198, 199, 405] for systems similar to Example 6.21.

Mather has announced a proof of the Conjecture on p. 287 (in the case of three degrees of freedom) for unperturbed Hamiltonians that are convex with respect to the action variables [418].

Numerical experiments show that the evolution of the action variables apparently is not of directional nature, but is a more or less random walk along resonances around the invariant tori. This process is called “*diffusion*”³⁶ [620]. The discussion of the questions arising here can be found in [189, 402, 620].

For generic systems diffusion happens exponentially slowly. The corresponding genericity condition is called the *steepness condition*. An analytic function is said to be *steep* if it has no stationary points and its restriction to any plane of any dimension has only isolated stationary points.³⁷

Theorem 6.21 (Nekhoroshev [40, 474]). *If the unperturbed Hamiltonian $H_0(I)$ is a steep function, then there exist a, b, c such that in the perturbed Hamiltonian system for a sufficiently small perturbation we have $|I(t) - I(0)| < \varepsilon^b$ for $0 \leq t \leq (1/\varepsilon) \exp(c^{-1}/\varepsilon^a)$. Here a, b, c are positive constants depending on the characteristics of the unperturbed Hamiltonian.*

◁ The proof is based on the following considerations. In a domain where the frequencies of the unperturbed motion do not satisfy any resonance relations of order up to $1/\varepsilon$, the procedure for eliminating the phases of § 6.2.2.A (Lindstedt’s method) allows one to defer the dependence on the phases to exponentially small terms of the Hamiltonian. Consequently, in this domain the evolution can be only exponentially slow.

Fast evolution (with rate of order ε) is possible only at a resonance. Near a resonance the procedures of § 6.2.2.B (von Zeipel’s method) allows one to defer the dependence on non-resonant combinations of the phases to exponentially small terms. Discarding these terms we obtain a system which has linear integrals by Theorem 6.15. Fast evolution takes place in the plane defined by these integrals. The condition of exact resonance consists, as is easy to calculate, in that the gradient of the restriction of H_0 to this plane vanishes. Since H_0 is a steep function, an exact resonance occurs at an isolated point. Consequently, the resonance is destroyed in the evolution. Therefore fast evolution

³⁶ *Translator’s note:* Nowadays the term “Arnold diffusion” became universally accepted.

³⁷ The notion of steepness was introduced by Nekhoroshev [473]. Here as the definition we stated a necessary and sufficient condition for steepness [480]. (First the following sufficient condition for steepness was proved: stationary points should be complex-isolated [290].)

goes on only for a short time; this is what yields an exponentially small upper estimate of the average rate of the evolution. \triangleright

If the steepness condition is not satisfied, then, as Example 6.20 shows, evolution can proceed with rate of order ε and can cause the slow variables going away to a distance of order 1 over time $1/\varepsilon$.

The rate of diffusion is different in different parts of the phase space. In particular, consider the δ -neighbourhood of an n -dimensional invariant torus carrying conditionally periodic motions with frequency vector ω satisfying the strong incommensurability condition

$$|(k, \omega)| > c_1^{-1} |k|^{-\nu}, \quad c_1, \nu = \text{const} > 0, \quad k \in \mathbb{Z}^n \setminus \{0\}.$$

In this neighbourhood the rate of diffusion is superexponentially small [432]: the time required for the slow variables (appropriately defined) to change by a quantity of order δ is at least

$$\exp \left(\frac{1}{\varepsilon^{a_1}} \exp \frac{1}{\delta^{a_2}} \right),$$

where a_1, a_2 are positive constants. Indeed, in the δ -neighbourhood of the invariant torus the system is close to a system with constant frequencies. According to [550] there is a canonical near-identity change of variables that defers the dependence on the fast phases in the Hamiltonian of this system to exponentially small terms $O(\varepsilon \exp(-1/\delta^d))$, $d = \text{const} > 0$ (cf. § 6.1.5). The resulting system can again be regarded as a system of the form (6.46), only H_0 depends on ε , the domain of definition of the system depends on δ , and H_1 is exponentially small in $1/\delta$. Repeating the estimates in the proof of Theorem 6.21 for the resulting system we obtain a superexponential estimate for the rate of diffusion.³⁸

There is a version of Theorem 6.21 for the case of proper degeneracy where the Hamiltonian has the form

$$H = H_0(I) + \varepsilon H_1(I, \varphi, p, q),$$

where (I, p) are the momenta and (φ, q) are their conjugate coordinates. If the unperturbed Hamiltonian $H_0(I)$ is a steep function, then the variables I satisfy the estimates of Theorem 6.21, provided that during the time under consideration the variables (p, q) remain in a given compact set inside the domain of definition of the system [40]. For instance, for the planetary n -body problem (Example 6.16) the unperturbed Hamiltonian has the form

$$H_0 = - \sum_{j=1}^{n-1} \frac{k_j}{L_j^2}, \quad (6.58)$$

³⁸ And repeating the estimates in the proof of Theorem 6.16 for the resulting system shows that near the invariant torus under consideration the Kolmogorov set is exponentially condensing [432].

where the k_j are positive constants and the L_j are the Delaunay variables. (See Ch. 2; recall that L_j is the action variable for the unperturbed Keplerian motion of the j th planet around the Sun, $L_j = \beta_j \sqrt{a_j}$, where a_j is the major semiaxis of the Keplerian ellipse of the j th planet, and $\beta_j = \text{const} > 0$.) Therefore we can assert that the major semiaxes of the planets change little over exponentially long time, provided the changes of the eccentricities and inclinations during this time do not cause collisions (or near-collisions) of the planets or transitions (near-transitions) to hyperbolic orbits. (If the initial eccentricities and inclinations are small and the planets are moving in the same direction, then the additional condition on the behaviour of the eccentricities and inclinations is unnecessary: the existence of the integral of angular momentum implies that, as long as the changes of the major semiaxes are small, the eccentricities and inclinations remain small; cf. Example 6.16.) Upper estimates for the rate of diffusion in the n -body problem are contained in [478].

An important special case of steep functions is provided by quasi-convex functions. A function is said to be *quasi-convex* if it has no stationary points and the restriction of the quadratic part of its Taylor expansion at any point to the tangent hyperplane to the level surface of the function is a sign-definite quadratic form. For example, the Hamiltonian (6.58) is a quasi-convex function. The level surfaces of a quasi-convex function are convex. For the case where the unperturbed Hamiltonian is a quasi-convex function the estimates of Nekhoroshev's theorem are proved with $a = b = 1/2n$, where n is the number of degrees of freedom of the system (and if there is a proper degeneracy, then n is the number of the action variables on which the unperturbed Hamiltonian depends) [398, 511]. This result sharpens the earlier successively improving estimates [103, 395, 472]. The works [189, 597] contain heuristic arguments and numerical estimates for the rate of diffusion of the action variables, according to which the estimate $a = 1/2n$ seems to be optimal. The examples constructed very recently in [396] show that this estimate is at least very close to being optimal.

One of the methods for obtaining the estimate $a = b = 1/2n$ in [398] is based on the following approach suggested in [395]. Near each point of the phase space there passes a periodic solution of the unperturbed system (the periodic solutions fill the maximally resonant invariant tori, whose union is everywhere dense). In a neighbourhood of such a periodic solution the full system has a single rapidly rotating phase; this phase corresponds to the motion along the periodic solution. The standard procedure of perturbation theory for single-frequency systems provides a canonical change of variables eliminating the dependence of the Hamiltonian on this phase ([455]; cf. Theorem 6.2). Therefore the action variable conjugate to this phase (we denote this "action" by I) changes only exponentially slowly. Consequently, during exponentially long time ($\sim \exp(c^{-1}/\varepsilon^{1/2n})$, as calculations show) the value of this variable is constant with an exponential accuracy. We can now apply the geometric argument of [472] using the quasi-convexity of the unperturbed Hamiltonian. The phase point in the space of "actions" must be situated near

the intersection of a convex level surface $H_0(I) = \text{const}$ of the unperturbed Hamiltonian and a plane³⁹ $\Gamma = \text{const}$. This surface and this plane are almost tangent; consequently, their intersection has small diameter ($O(\varepsilon^{1/2n})$, as can be calculated). Therefore the change of the “actions” proves to be bounded by a quantity of the same order.

For arbitrary steep unperturbed Hamiltonians, important estimates of the constants a and b in Theorem 6.21 were recently obtained in [479].

It is interesting to note that Theorem 6.21 in the quasi-convex case can be carried over (with almost the same estimates for a and b) to Gevrey smooth (not necessarily analytic) Hamiltonians [406, 407, 535].

For an excellent recent survey on the exponential estimates for the diffusion rate of the action variables in nearly integrable Hamiltonian systems, see [259].

6.3.5 Diffusion without Exponentially Small Effects

In a number of problems the evolution of the slow variables along transition chains takes place in the absence of exponentially small effects. Such “diffusion” is easier to study and it is widely discussed; see, for example, [182, 186, 285, 608]. However, in many cases the complete constructions of transition chains are not carried out.

We point out the following system, in which the motion along a transition chain takes place without an explicit small parameter.

Example 6.22 ([417]). Consider a natural Lagrangian system on the torus \mathbb{T}^2 :

$$L(q, \dot{q}, t) = T(q, \dot{q}) - V(q, t).$$

Suppose that the kinetic energy T (a Riemannian metric on the torus) satisfies the following genericity conditions.

1. It is assumed that a shortest closed geodesic in some homotopy class of closed curves on the torus is unique and non-degenerate.

Morse proved [434] that such a geodesic $s \mapsto \gamma(s)$ always has a homoclinic geodesic $s \mapsto \sigma(s)$, that is, there exist a_{\pm} such that $\text{dist}(\sigma(s), \gamma(s + a_{\pm})) \rightarrow 0$ as $s \rightarrow \pm\infty$.

2. The homoclinic trajectory σ is assumed to be transversal, that is, the stable and unstable manifolds of the geodesic γ intersect at non-zero angle along the curve in the phase space corresponding to σ .

We can suppose without loss of generality that $\oint V(\gamma(s), t) ds \equiv 0$.

3. The Poincaré–Mel’nikov function

$$P(t) = \lim_{T \rightarrow +\infty} \left(\int_{-T}^T V(\sigma(s), t) ds - \int_{-T+a_-}^{T+a_+} V(\gamma(s), t) ds \right)$$

³⁹ The equation $\Gamma = \text{const}$ defines a plane, since Γ is a linear combination of the original “actions” with integer coefficients; cf. Theorem 6.15.

is assumed to be non-constant.

Under conditions 1–3 Mather [417] proved that there exists a trajectory $q(t)$ of the Lagrangian system such that $|\dot{q}(t)| \rightarrow \infty$.

The proof is based on variational methods. A generalization of this result to the multidimensional case was obtained in [135, 203].

It is useful to bear in mind that the absence of a small parameter in this system is merely an illusion. Such a parameter emerges as the ratio of the potential and kinetic energies V/T under the condition that the total energy $T + V$ is sufficiently large.

Recently de la Llave and Piftankin independently announced a linear in time lower estimate for the rate of increase of the energy on the “fastest” solution of the system. Note that this estimate has the same order as the obvious upper estimate because

$$\left| \frac{d}{dt}(T + V) \right| = \left| \frac{\partial}{\partial t} V \right| \leq \text{const.}$$

△

Another important class of systems in which diffusion is not exponentially slow is provided by the so-called a priori unstable systems. The Hamiltonian of such a system has the form $H = H_0 + \varepsilon H_1 + O(\varepsilon^2)$, where $H_0 = H_0(I, p, q)$ and $H_1 = H_1(I, \varphi, p, q, t)$. Here it is assumed that $I \in D_0 \subset \mathbb{R}^n$, $\varphi \in \mathbb{T}^n \bmod 2\pi$, $(p, q) \in D \subset M^2$; D_0 and D are open domains, M^2 is a two-dimensional smooth manifold (normally, a plane or a cylinder); the dependence of the Hamiltonian on time t is assumed to be 2π -periodic; I, φ and p, q are pairs of canonically conjugate variables. For $\varepsilon = 0$ the variables I are first integrals. Thus, for $\varepsilon = 0$ the system reduces to a system with one degree of freedom and, consequently, is integrable. The class of a priori unstable systems is defined by the following assumption: for any $I = I^0 \in D_0$ the system with one degree of freedom and with Hamiltonian $H_0(I^0, p, q)$ has a saddle (non-degenerate) equilibrium position $(p_c(I^0), q_c(I^0))$ whose stable and unstable separatrices are doubled; the functions p_c, q_c are smooth. In particular, the system in Example 6.21 belongs to the class of a priori unstable systems if $\varepsilon = 1$ and μ is regarded as the only small parameter.

The situation becomes much clearer if we restrict ourselves to a priori unstable systems with two and a half degrees of freedom (the smallest interesting dimension). In this case there is only one slow variable I whose evolution should be regarded as a diffusion. A geometric description of the mechanism of the diffusion is presented in [204]. The genericity of the diffusion is proved in [591, 176]: in [591] a multidimensional version of the separatrix map is used, while the methods of [176] are variational. Moreover, in [591] “fast” diffusion trajectories are constructed: the average velocity of the action evolution is of order $\varepsilon / \log |\varepsilon|$ (it is clear that the action I cannot move faster). This result was obtained under the assumptions that H_0 is real-analytic, $H_0 = F(I_0, f(p, q))$ (that is, the variables are separated in the unperturbed system), and the fre-

quency $\frac{\partial H_0}{\partial I}(I, p_c(I), q_c(I))$ is non-zero at the so-called strong resonances (for example, it vanishes nowhere).

6.3.6 Variants of the Theorem on Invariant Tori

A. Invariant Tori of Symplectic Maps

We consider a map of a $2n$ -dimensional “annulus” close to an n -dimensional rotation:

$$\begin{aligned} I' &= I + \varepsilon f(I, \varphi, \varepsilon), & I &\in B \subset \mathbb{R}^n, \\ \varphi' &= \varphi + h(I) + \varepsilon g(I, \varphi, \varepsilon), & \varphi &\text{ modd } 2\pi \in \mathbb{T}^n. \end{aligned} \tag{6.59}$$

Suppose that this map is exact symplectic, that is, it preserves integrals of the 1-form $I d\varphi$ over closed contours. The unperturbed ($\varepsilon = 0$) map is said to be *non-degenerate* if $\det(\partial h/\partial I) \neq 0$.

Theorem 6.22 ([87, 214]). *Suppose that the unperturbed map is analytic and non-degenerate. Then for a sufficiently small perturbation of class C^r , $r > 2n + 1$, in the annulus $B \times \mathbb{T}^n$ there are invariant tori close to the tori $I = \text{const}$, and the measure of the complement of their union is small when the perturbation is small. The images of a point of a torus under iterations of the map fill the torus everywhere densely.*

If $n = 1$, then we obtain an area-preserving map of a conventional circular annulus (Fig. 6.28). The unperturbed ($\varepsilon = 0$) map is a rotation on each circle $I = \text{const}$. The non-degeneracy condition means that the rotation angle changes from one circle to another (Fig. 6.28a). A circle whose rotation angle is 2π -irrational is called non-resonant; the images of any of its points under

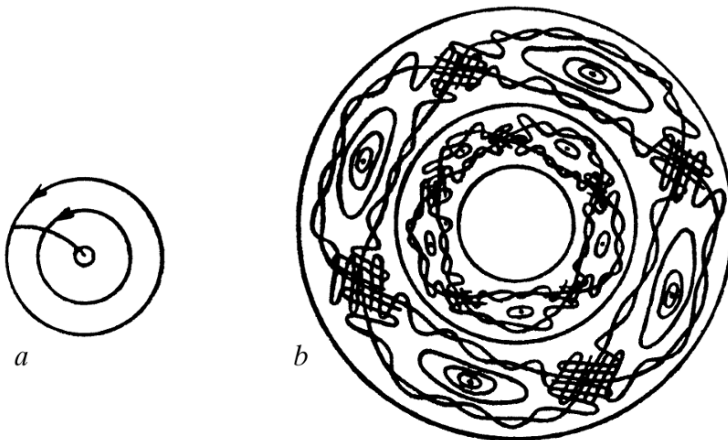

Fig. 6.28.

iterations of the map fill such a circle everywhere densely. A circle whose rotation angle is 2π -rational is called resonant; it consists of periodic points of the unperturbed map.

The non-resonant circles (satisfying the additional condition that their rotation angle α is not too well approximable by 2π -rational numbers:

$$\left| \alpha - \frac{2\pi p}{q} \right| > c\sqrt{\varepsilon}q^{-\nu}, \quad n + 1 < \nu < \frac{1}{2}(r + 1)$$

do not disappear under the perturbation but are merely slightly deformed. The resonant circles are destroyed (Fig. 6.28*b*).

The theorems on invariant tori for Hamiltonian systems and symplectic maps were first being proved independently (although by virtually identical methods). These theorems can be derived from one another, since the Poincaré return map for a Hamiltonian system has the form (6.59) and, conversely, every map of the form (6.59) can be obtained as such a Poincaré return map [214, 362]. The last assertion is valid both in the case of finite smoothness or C^∞ and in the analytic case [214, 362, 514].

B. Invariant Tori in the Theory of Small Oscillations

Other cases where there exist Kolmogorov tori are related to the theory of small oscillations. In particular, consider a Hamiltonian system with n degrees of freedom in a neighbourhood of an equilibrium position. Suppose that the equilibrium is stable in the linear approximation, so that n eigenfrequencies $\omega_1, \dots, \omega_n$ are well defined. Furthermore, assume that these frequencies do not satisfy resonance relations of order up to and including 4:

$$k_1\omega_1 + \dots + k_n\omega_n \neq 0 \quad \text{for} \quad 0 < |k_1| + \dots + |k_n| \leq 4.$$

Then the Hamiltonian function can be reduced to the Birkhoff normal form (see § 8.3)

$$H = H_0(\tau) + \dots, \quad H_0(\tau) = \sum \omega_i \tau_i + \frac{1}{2} \sum \omega_{ij} \tau_i \tau_j, \quad \tau_i = \frac{1}{2}(p_i^2 + q_i^2).$$

Here the dots denote terms of order higher than four with respect to the distance from the equilibrium position. The system is said to be *non-degenerate* in a neighbourhood of the equilibrium position if

$$\det \left(\frac{\partial^2 H_0}{\partial \tau^2} \right)_0 = \det(\omega_{ij}) \neq 0.$$

The system is said to be *isoenergetically non-degenerate* if

$$\det \begin{pmatrix} \frac{\partial^2 H_0}{\partial \tau^2} & \frac{\partial H_0}{\partial \tau} \\ \frac{\partial H_0}{\partial \tau} & 0 \end{pmatrix}_0 = \det \begin{pmatrix} \omega_{ij} & \omega_i \\ \omega_j & 0 \end{pmatrix} \neq 0.$$

If the system is non-degenerate or isoenergetically non-degenerate, then we say that the Hamiltonian is of general elliptic type.

The system with Hamiltonian H_0 is integrable and the motion in it takes place on the invariant tori $\tau = \text{const}$. Consequently, the system with Hamiltonian H is nearly integrable in a sufficiently small neighbourhood of the equilibrium position. This situation is similar to the situation of Kolmogorov's theorem.

Theorem 6.23 ([7, 36]). *A Hamiltonian of general elliptic type in a neighbourhood of an equilibrium position has invariant tori close to the tori of the linearized system. These tori form a set whose relative measure in the polydisc $|\tau| < \varepsilon$ tends to 1 as $\varepsilon \rightarrow 0$. In an isoenergetically non-degenerate system such tori occupy a larger part of each energy level passing near the equilibrium position.*

Remark 6.20. The relative measure of the set of invariant tori in the polydisc $|\tau| < \varepsilon$ is at least $1 - O(\varepsilon^{1/4})$. If the frequencies do not satisfy resonance relations of order up to and including $l \geq 4$, then this measure is even at least $1 - O(\varepsilon^{(l-3)/4})$; see [509]. If the frequencies satisfy the strong incommensurability condition, then (in an analytic system) this measure is $1 - O(\exp(-c^{-1}/\varepsilon^\alpha))$ for $c, \alpha = \text{const} > 0$; see [202, 298].

In the case $n = 2$ the isoenergetic non-degeneracy guarantees the Lyapunov stability of the equilibrium [7]. For $n = 2$ the condition of isoenergetic non-degeneracy amounts to the fact that the quadratic part of the function H_0 is not divisible by the linear part of H_0 . Even if the quadratic part is divisible by the linear part, the equilibrium is nevertheless, as a rule, stable. Namely, suppose that the frequencies ω_1 and ω_2 do not satisfy resonance relations of order up to and including $l \geq 4$. Then the Hamiltonian function can be reduced to the normal form

$$H = H_0(\tau_1, \tau_2) + \dots, \quad H_0 = \sum_{1 \leq i+j \leq [l/2]} A_{ij} \tau_1^i \tau_2^j,$$

where the dots denote terms of order higher than l with respect to the distance from the equilibrium position. Consider the function $h_0(\varepsilon) = H_0(\varepsilon\omega_2, -\varepsilon\omega_1)$. If $h_0(\varepsilon)$ is not identically equal to zero, then the equilibrium is stable [71].

Other cases where analogous assertions on invariant tori and on stability hold are related to the theory of small oscillations in a neighbourhood of an equilibrium position of a system with periodic or conditionally periodic coefficients, in a neighbourhood of a periodic solution of an autonomous Hamiltonian system, and in a neighbourhood of a fixed point of a symplectic map. The corresponding statements are given in [10].

C. Quasi-Periodic Invariant Manifolds

Invariant manifolds pertaining to Kolmogorov tori exist in problems of quasi-periodic Hamiltonian perturbations. (These problems were pointed out by

Tennison; see also [299] and the references therein.) In this case the Hamiltonian has the form

$$H = H_0(p) + \varepsilon H_1(p, Aq, \varepsilon), \quad (p, q) \in \mathbb{R}^{2n},$$

where p, q are conjugate variables, $A: \mathbb{R}^n \rightarrow \mathbb{R}^m$ is a linear operator, and the perturbation H_1 has period 2π in $\varphi = Aq$. It is assumed that $m \geq n$ and the rank of A is equal to n (otherwise the order of the system can be lowered), and the adjoint operator $A^*: \mathbb{R}^m \rightarrow \mathbb{R}^n$ of A does not cast integer vectors to 0 (otherwise the number of angle variables φ can be decreased). Suppose that the unperturbed Hamiltonian H_0 is non-degenerate or isoenergetically non-degenerate, and the operator A^* satisfies the following strong incommensurability condition: $|A^*k| > c^{-1}|k|^{-\nu}$ for all $k \in \mathbb{Z}^m \setminus \{0\}$, where $c, \nu = \text{const} > 0$. Then a larger part of the phase space (in the case of isoenergetic non-degeneracy, even of each energy level) is filled with n -dimensional invariant manifolds that are quasi-periodic in q and are close to the “planes” $p = \text{const}$. These manifolds are obtained from the m -dimensional Kolmogorov tori of the auxiliary system with Hamiltonian

$$H = H_0(A^*I) + \varepsilon H_1(A^*I, \varphi, \varepsilon), \quad I \in \mathbb{R}^m, \quad \varphi \bmod 2\pi \in \mathbb{T}^m,$$

by the substitution $p = A^*I$, $\varphi = Aq$.

The proof of the existence of the tori is based on the procedure for eliminating the fast variables of §6.2.2.C and goes through as usual, since at each step of the procedure everything depends on A^*I , rather than on I . The strong incommensurability condition allows one to estimate the arising small denominators.

If $n = 2$ and the Hamiltonian H_0 is isoenergetically non-degenerate, then the invariant manifolds thus constructed divide energy levels and there is no evolution of the slow variables p .

6.3.7 KAM Theory for Lower-Dimensional Tori

Almost the entire theory of perturbations of conditionally periodic motions of Hamiltonian systems can be generalized to the case where the unperturbed system is integrable not in the whole phase space but merely on some surface. This surface is foliated into invariant tori whose dimension is smaller than the number of degrees of freedom. In perturbation theory of such *lower-dimensional* tori a central role is played by the notions of *isotropy* and *reducibility*, which also make sense for ordinary Kolmogorov tori, but so far stayed in the background in our exposition.

A. Isotropy

Let M^{2n} be a smooth even-dimensional manifold on which a closed non-degenerate 2-form ω^2 defines a symplectic structure. A submanifold $N \subset M^{2n}$

is said to be *isotropic* if the restriction of the form ω^2 to N vanishes (and, in particular, $\dim N \leq n$). An isotropic submanifold $N \subset M^{2n}$ of maximum possible dimension n is called *Lagrangian*. For example, the invariant tori $I = \text{const}$ of a completely integrable Hamiltonian system with Hamiltonian $H_0(I)$ are Lagrangian.

Let T be an invariant torus of a Hamiltonian system, on which the motion is conditionally periodic. It turns out that if the frequencies of the motion on T are rationally independent and the 2-form ω^2 defining the symplectic structure is exact, that is, $\omega^2 = d\omega^1$ (the last condition almost always holds in the Hamiltonian systems of mechanical origin), then the torus T is isotropic (Herman's theorem [280]; see also [17]). In particular, the Kolmogorov tori are Lagrangian.

B. Reducibility

An invariant torus T of some autonomous (not necessarily Hamiltonian) system of ordinary differential equations, on which the motion is conditionally periodic with frequency vector ω , is said to be *reducible* if in a neighbourhood of T there exist coordinates $(x, \varphi \bmod 2\pi)$ in which the torus T is given by the equation $x = 0$ and the system takes the so-called *Floquet form*

$$\dot{x} = Ax + O(|x|^2), \quad \dot{\varphi} = \omega + O(|x|), \tag{6.60}$$

where the matrix A , called the *Floquet matrix*, is independent of φ . Both the unperturbed and the perturbed invariant tori in Kolmogorov's Theorem 6.16 are reducible with zero Floquet matrix.

Now suppose that an autonomous Hamiltonian system with $n + m$ degrees of freedom has a smooth invariant $2n$ -dimensional surface Π that is smoothly foliated into isotropic reducible invariant n -dimensional tori, on which the motion is conditionally periodic ($n \geq 1$). One can show [17] that in a neighbourhood of such a surface (or, at least, in a neighbourhood of any point of the surface) it is always possible to introduce coordinates $(I, \varphi \bmod 2\pi, z)$ having the following properties.

1°. $I \in G$ (where G is a domain in \mathbb{R}^n), $\varphi \in \mathbb{T}^n$, and z varies in a neighbourhood of the origin in \mathbb{R}^{2m} .

2°. In the coordinates (I, φ, z) the symplectic structure has the form

$$\sum_{i=1}^n dI_i \wedge d\varphi_i + \sum_{j=1}^m dz_j \wedge dz_{j+m}.$$

3°. In the coordinates (I, φ, z) the Hamiltonian of the system has the form

$$H_0(I, \varphi, z) = F(I) + \frac{1}{2}(K(I)z, z) + R(I, \varphi, z), \tag{6.61}$$

where $K(I)$ is a symmetric matrix of order $2m$ depending on I , the parentheses $(,)$ as usual denote the scalar product of vectors, and $R = O(|z|^3)$.

The Hamiltonian H_0 affords the system of equations

$$\dot{I} = O(|z|^3), \quad \dot{\varphi} = \omega(I) + O(|z|^2), \quad \dot{z} = \Omega(I)z + O(|z|^2),$$

where $\omega(I) = \partial F(I)/\partial I$, $\Omega(I) = JK(I)$, and

$$J = \begin{pmatrix} 0_m - E_m & \\ E_m & 0_m \end{pmatrix}$$

is the symplectic unit matrix of order $2m$ (here 0_m and E_m are the zero and identity $m \times m$ -matrices, respectively).

The surface Π in whose neighbourhood the coordinates (I, φ, z) are defined is given by the equality $z = 0$, and the invariant n -dimensional tori into which this surface is foliated are given by the equalities $z = 0$, $I = \text{const}$. The motion on the tori $z = 0$, $I = \text{const}$ is conditionally periodic with frequency vectors $\omega(I)$. Furthermore, these tori are isotropic and reducible with Floquet matrix $\Omega(I) \oplus 0_n$.

We now consider the perturbed system with Hamiltonian

$$H(I, \varphi, z, \varepsilon) = H_0(I, \varphi, z) + \varepsilon H_1(I, \varphi, z, \varepsilon). \quad (6.62)$$

The KAM theory for lower-dimensional tori is designed to answer the question of what happens to the tori $z = 0$, $I = \text{const}$ under such a perturbation.

Theorem 6.24. *Suppose that the functions $\omega(I)$ and $\Omega(I)$ satisfy certain non-degeneracy and non-resonance conditions given below. Then in the phase space of the perturbed system there are also isotropic reducible invariant n -dimensional tori, on which the motion is conditionally periodic with rationally independent frequencies. These tori are close to the unperturbed tori $z = 0$, $I = \text{const}$. The measure of the complement of the union of the images of the perturbed tori under the projection $(I, \varphi, z) \mapsto (I, \varphi, 0)$ onto the surface $\Pi = \{z = 0\}$ is small together with the perturbation.*

There exist many versions of this theorem differing in the set of conditions of non-degeneracy and non-resonance that are imposed on the functions $\omega(I)$ and $\Omega(I)$. The proof of the theorem depends on these conditions. However, on the whole, the proof follows the scheme of the proof of the conventional Kolmogorov Theorem 6.16 (relating to the case $m = 0$), but is characterized by considerably more complicated technical details.

Theorem 6.24 holds if both the unperturbed and the perturbed Hamiltonians are sufficiently smooth.

As in Kolmogorov's theorem, the perturbed n -dimensional tori are organized into a smooth family. Moreover, a smooth family is formed by the changes of coordinates reducing the perturbed Hamiltonian system to the Floquet form (6.60) in a neighbourhood of each torus; see [17, 146, 147].

This means the following. For any sufficiently small ε there exist a subset $G_\varepsilon \subset G \subset \mathbb{R}^n$ and smooth functions

$$\begin{aligned}\eta_\varepsilon &: \mathbb{R}^n \times \mathbb{T}^n \times \mathbb{R}^{2m} \times G \rightarrow \mathbb{R}^n, \\ \chi_\varepsilon &: \mathbb{R}^n \times \mathbb{T}^n \times \mathbb{R}^{2m} \times G \rightarrow \mathbb{R}^n, \\ \zeta_\varepsilon &: \mathbb{R}^n \times \mathbb{T}^n \times \mathbb{R}^{2m} \times G \rightarrow \mathbb{R}^{2m}, \\ \delta_\varepsilon &: G \rightarrow \mathbb{R}^n, \\ \Delta_\varepsilon &: G \rightarrow sp(m)\end{aligned}\tag{6.63}$$

(where $sp(m)$ is the space of Hamiltonian matrices of order $2m$, that is, matrices affording linear Hamiltonian systems with m degrees of freedom) having the following properties.

1°. The measure of the complement $G \setminus G_\varepsilon$ and the functions (6.63) are small together with ε .

2°. For any $I^* \in G_\varepsilon$, in the coordinates (I', φ', z') defined by the relations

$$\begin{aligned}I &= I' + I^* + \eta_\varepsilon(I', \varphi', z', I^*), \\ \varphi &= \varphi' + \chi_\varepsilon(I', \varphi', z', I^*), \\ z &= z' + \zeta_\varepsilon(I', \varphi', z', I^*),\end{aligned}$$

the perturbed Hamiltonian system afforded by the Hamiltonian (6.62) takes the form (6.60):

$$\begin{aligned}\dot{I}' &= O(|I'|^2 + |z'|^2), \\ \dot{\varphi}' &= \omega(I^*) + \delta_\varepsilon(I^*) + O(|I'| + |z'|), \\ \dot{z}' &= [\Omega(I^*) + \Delta_\varepsilon(I^*)]z' + O(|I'|^2 + |z'|^2).\end{aligned}\tag{6.64}$$

The set $z' = 0$, $I' = 0$ is an invariant n -dimensional torus of system (6.64). The motion on this torus is conditionally periodic with frequency vector $\omega(I^*) + \delta_\varepsilon(I^*)$. Furthermore, this torus is reducible with Floquet matrix $[\Omega(I^*) + \Delta_\varepsilon(I^*)] \oplus 0_n$. Thus, the perturbed invariant tori are labelled by points of the subset G_ε .

The smoothness of the functions (6.63) and, correspondingly, the topology in which the smallness of these functions is defined depend on the smoothness of the Hamiltonian (6.62). If this Hamiltonian is of finite smoothness or of smoothness class C^∞ , then so are also the functions (6.63) (and, consequently, the perturbed invariant tori and the family formed by them). If the Hamiltonian (6.62) is analytic, then the functions (6.63) are analytic in the phase space variables I', φ', z' (so that each perturbed invariant torus is also analytic), but merely infinitely differentiable in I^* (so that the torus family is merely infinitely differentiable). In fact, the functions (6.63) are Gevrey smooth in I^* for analytic Hamiltonians (6.62); see [602]. The situation is very similar to the situation of Kolmogorov's Theorem 6.16.

We now consider the conditions of non-degeneracy and non-resonance which must be satisfied by the functions $\omega(I)$ and $\Omega(I)$. We give only one of the possible sets of conditions, which is a lower-dimensional analogue of the Rüssmann non-degeneracy condition for completely integrable systems (see § 6.3.2). Before stating these conditions, recall that by $|a| = |a_1| + |a_2| + \dots$ we denote the l_1 -norm of a vector a . By $\|a\| = (a_1^2 + a_2^2 + \dots)^{1/2}$ we denote the l_2 -norm (the Euclidean norm) of a vector a . The conditions of non-degeneracy and non-resonance of the functions $\omega(I)$ and $\Omega(I)$ consist in the following three requirements [146, 17].

Condition (i). The spectrum of the matrix $\Omega(I)$ is simple for all $I \in G$ (and, in particular, $\det \Omega(I) \neq 0$ for all I). We denote the eigenvalues of the matrix $\Omega(I)$ by

$$\begin{aligned} \pm i\theta_j(I), & \quad 1 \leq j \leq c, \\ \pm\alpha_j(I) \pm i\beta_j(I), & \quad 1 \leq j \leq s, \\ \pm\gamma_j(I), & \quad 1 \leq j \leq m - c - 2s. \end{aligned}$$

Let

$$\lambda = \lambda(I) = (\theta_1, \dots, \theta_c, \beta_1, \dots, \beta_s)$$

be the vector of the *normal frequencies* of the unperturbed torus.

Condition (ii). There exists a positive integer N such that for all $I \in G$ the partial derivatives $D^q\omega(I) \in \mathbb{R}^n$ for $q \in \mathbb{Z}_+^n$, $0 \leq |q| \leq N$, span (in the sense of linear algebra) the entire space \mathbb{R}^n .

Condition (iii). For any value of $I \in G$, any vector $l \in \mathbb{Z}^{c+s}$ such that $1 \leq |l| \leq 2$, and any vector $k \in \mathbb{Z}^n$ such that

$$1 \leq \|k\| \leq \frac{\max_{r=0}^N r! \max_{\|u\|=1} \left| \sum_{|q|=r} (D^q\lambda(I), l) \frac{u^q}{q!} \right|}{\min_{\|e\|=1} \max_{r=0}^N r! \max_{\|u\|=1} \left| \sum_{|q|=r} (D^q\omega(I), e) \frac{u^q}{q!} \right|} \tag{6.65}$$

we have the inequality

$$(\omega(I), k) \neq (\lambda(I), l). \tag{6.66}$$

Here $q! = q_1! \dots q_n!$, $u^q = u_1^{q_1} \dots u_n^{q_n}$, and the minimum, maxima, and sums are taken over $r \in \mathbb{Z}_+$, $q \in \mathbb{Z}_+^n$, $u \in \mathbb{R}^n$, $e \in \mathbb{R}^n$. Condition (ii) is equivalent to the fact that the denominator in (6.65) is non-zero.

◁ In the lower-dimensional case the small denominators arising in the procedure for eliminating the fast phases have the form $(\omega, k) + (\lambda, l)$, where ω is the frequency vector of the motion on the torus, λ is the vector of normal frequencies of the torus (defined by the positive imaginary parts of the eigenvalues

of the Floquet matrix), k and l are integer vectors, $k \neq 0$, and $|l| \leq 2$. Conditions (ii) and (iii) guarantee that for any C^N -map $(\tilde{\omega}, \tilde{\lambda}): G \rightarrow \mathbb{R}^n \times \mathbb{R}^{c+s}$ that is sufficiently close to (ω, λ) the measure of the complement of the Cantor set

$$\{I \in G: |(\tilde{\omega}, k) + (\tilde{\lambda}, l)| > \varkappa|k|^{-\nu} \quad \forall k \in \mathbb{Z}^n \setminus \{0\} \quad \forall l \in \mathbb{Z}^{c+s}, \quad |l| \leq 2\}$$

tends to zero as $\varkappa \rightarrow 0$ for any fixed $\nu > nN - 1$; see [17]. This measure is actually equal to $O(\varkappa^{1/N})$. One can show that the interval (6.65) of values of $\|k\|$ for which inequality (6.66) must hold cannot be shortened [17].

Under the above non-degeneracy and non-resonance conditions the measure of the set $G \setminus G_\varepsilon$ and therefore the measure of the complement of the union of the images of the perturbed tori under the projection $(I, \varphi, z) \mapsto (I, \varphi, 0)$ onto the surface $\Pi = \{z = 0\}$ are $O(\varepsilon^{1/(2N)})$. ▷

Other sets of non-degeneracy and non-resonance conditions suitable for Theorem 6.24 can be found, for example, in [141, 185, 187, 225, 242, 253, 381, 390, 510, 528, 609, 610, 611, 612, 617, 618].

Both the unperturbed and perturbed invariant n -dimensional tori in Theorem 6.24 are said to be *hyperbolic* if the matrices $\Omega(I)$ have no purely imaginary eigenvalues ($c = 0$), and *elliptic* if, on the contrary, all the eigenvalues of the matrices $\Omega(I)$ are purely imaginary ($c = m, s = 0$).

A fundamental difference between the lower-dimensional situation and the situation of Kolmogorov’s Theorem 6.16 is that in the lower-dimensional case, even if the frequency map $I \mapsto \omega(I)$ is a diffeomorphism, for none of the vectors ξ in the set $\omega(G) \subset \mathbb{R}^n$ of values of the unperturbed frequencies can one guarantee that for any sufficiently small perturbation there exists a perturbed torus with frequency vector ξ . The reason for this is the existence of cross resonances between the “internal” frequencies ω_i and the normal frequencies λ_j . The only exception is the case where all the eigenvalues of the matrices $\Omega(I)$ are real ($c = s = 0$). In this case the frequency vectors of the motion on the perturbed tori fill the entire Cantor set

$$\Xi_\varkappa = \{\xi \in \omega(G): |(\xi, k)| > \varkappa|k|^{-\nu} \quad \forall k \in \mathbb{Z}^n \setminus \{0\}\} \tag{6.67}$$

(if $\det(\partial\omega/\partial I) \neq 0$), where ν is a fixed number greater than $n - 1$, and \varkappa is a quantity of order $\sqrt{\varepsilon}$. Furthermore, the perturbed tori depend smoothly on ε . The set G_ε above is $G_\varepsilon = \{I \in G: \omega(I) \in \Xi_\varkappa\}$, while $\delta_\varepsilon \equiv 0$.

The study of lower-dimensional tori was started by Mel’nikov [421, 422] and Moser [35]. The hyperbolic case was considered in detail in [110, 265, 622]. A systematic study of the considerably more difficult elliptic (more generally, non-hyperbolic) case was started in [225, 510]. Among later papers we mention [17, 111, 141, 146, 147, 185, 187, 298, 299, 380, 381, 390, 528, 547, 609, 610, 611, 612, 617, 618].

As Kolmogorov’s theorem, Theorem 6.24 has an analogue relating to theory of small oscillations. Namely, suppose that among the eigenvalues of the linearization of an autonomous Hamiltonian system with $n + m$ degrees of freedom about an equilibrium position there are $n \geq 1$ pairs of purely imaginary

eigenvalues $\pm i\omega_1, \dots, \pm i\omega_n$ (some of the remaining $2m$ eigenvalues may also be purely imaginary). Then under certain non-degeneracy and non-resonance conditions, in any neighbourhood of the equilibrium position the system has isotropic reducible invariant n -dimensional tori, which carry conditionally periodic motion with rationally independent frequencies close to $\omega_1, \dots, \omega_n$; see [510].

Theorem 6.24 above and its local analogue, which was just briefly stated, can be regarded as limiting special cases of a certain more general assertion. Namely, let us return to the system with Hamiltonian (6.61). Suppose that the tori $z = 0, I = \text{const}$ are not hyperbolic, so that the matrices $\Omega(I)$ describing in the linear approximation the motion in a neighbourhood of the surface $\Pi = \{z = 0\}$ have $c \geq 1$ pairs of purely imaginary eigenvalues $\pm i\theta_1(I), \dots, \pm i\theta_c(I)$. From these c pairs we choose arbitrary μ pairs ($1 \leq \mu \leq c$); for definiteness, $\pm i\theta_1(I), \dots, \pm i\theta_\mu(I)$.

Theorem 6.25 (on “excitation of elliptic normal modes” [17, 298, 543, 544]). *Suppose that the functions $\omega(I)$ and $\Omega(I)$ satisfy certain non-degeneracy and non-resonance conditions indicated below. Then in any neighbourhood of the surface $\Pi = \{z = 0\}$ the system with Hamiltonian (6.61) has isotropic reducible invariant $(n + \mu)$ -dimensional tori, on which the motion is conditionally periodic with rationally independent frequencies close to $\omega_1(I), \dots, \omega_n(I), \theta_1(I), \dots, \theta_\mu(I)$. The same is also true for the perturbed system with Hamiltonian (6.62) if ε does not exceed a quantity $o(\rho^2)$, where ρ is the radius of the neighbourhood of the surface Π under consideration. The measure of the complement of the union of the images of these $(n + \mu)$ -dimensional tori under a suitable projection onto a suitable $2(n + \mu)$ -dimensional surface tends to zero as $\rho + \rho^{-2}\varepsilon \rightarrow 0$.*

One of the possible sets of non-degeneracy and non-resonance conditions in Theorem 6.25 (see [17, 544]) consists in the validity of the non-resonance condition (i) in Theorem 6.24, as well as the non-degeneracy and non-resonance conditions (ii) and (iii) with the maps ω and λ replaced by the maps

$$\begin{aligned} I &\mapsto \widehat{\omega}(I) = (\omega_1, \dots, \omega_n, \theta_1, \dots, \theta_\mu)|_I \quad \text{and} \\ I &\mapsto \widehat{\lambda}(I) = (\theta_{\mu+1}, \dots, \theta_c, \beta_1, \dots, \beta_s)|_I, \end{aligned}$$

respectively (here $q \in \mathbb{Z}_+^{n+\mu}$, $D^q \widehat{\omega}(I) \in \mathbb{R}^{n+\mu}$, $l \in \mathbb{Z}^{c+s-\mu}$, $k \in \mathbb{Z}^{n+\mu}$, $u \in \mathbb{R}^{n+\mu}$, $e \in \mathbb{R}^{n+\mu}$). Another set is indicated in [298]. A detailed comparison of these two different sets of non-degeneracy and non-resonance conditions was carried out in [543]. Excitation of elliptic normal modes was recently considered also by Herman.

We excluded the cases $n = 0$ and $\mu = 0$ from the statement of Theorem 6.25. For $\mu = 0$ Theorem 6.25 turns into Theorem 6.24, and for $n = 0$, into the local analogue of Theorem 6.24 (in which, however, the appropriate non-degeneracy and non-resonance conditions are formulated in terms of the coefficients of the Birkhoff normal form).

In conclusion we remark that in the hyperbolic situation the requirement of reducibility of the unperturbed tori can be dropped. Of course, then the perturbed tori, generally speaking, will not be reducible, too. Suppose that the unperturbed Hamiltonian has the form

$$H_0(I, \varphi, z) = F(I) + \frac{1}{2}(K(I, \varphi)z, z) + R(I, \varphi, z),$$

where the matrices $K(I, \varphi)$ are symmetric for all I and φ and, as before, $R = O(|z|^3)$. This Hamiltonian affords the system of equations

$$\dot{I} = O(|z|^2), \quad \dot{\varphi} = \omega(I) + O(|z|^2), \quad \dot{z} = \Omega(I, \varphi)z + O(|z|^2),$$

where $\omega(I) = \partial F(I)/\partial I$ and $\Omega(I, \varphi) = JK(I, \varphi)$. We consider the perturbed system with Hamiltonian (6.62).

Theorem 6.26 ([622], see also [265]). *Suppose that $\det(\partial\omega/\partial I) \neq 0$ and the matrices $\Omega(I, \varphi)$ have no purely imaginary eigenvalues. Then in the phase space of the perturbed system there exist isotropic invariant n -dimensional tori, on which the motion is conditionally periodic with rationally independent frequencies. These tori are close to the unperturbed tori $z = 0, I = \text{const}$. The frequency vectors of the motion on the perturbed tori fill the Cantor set (6.67), where ν is a fixed number greater than $n - 1$, and \varkappa is a quantity of order $\sqrt{\varepsilon}$. The perturbed tori depend smoothly on ε . The measure of the complement of the union of the images of the perturbed tori under the projection $(I, \varphi, z) \mapsto (I, \varphi, 0)$ onto the surface $\Pi = \{z = 0\}$ is $O(\sqrt{\varepsilon})$. Moreover, each perturbed torus has attracting and repelling “whiskers” – smooth Lagrangian invariant $(n + m)$ -dimensional manifolds on which the trajectories tend exponentially to the given torus as $t \rightarrow +\infty$ or as $t \rightarrow -\infty$, respectively.*

Other works where non-reducible hyperbolic lower-dimensional tori are explored are [194, 195, 287, 380]. In the papers [265, 287] the unperturbed tori are assumed to be reducible, and only the perturbed tori can be non-reducible. In the papers [194, 195, 380, 622], the unperturbed tori are allowed to be non-reducible as well. “Whiskers” of the non-reducible perturbed tori are constructed only in [265, 622].

In [141], in the elliptic situation, invariant tori of the perturbed system were constructed that are, generally speaking, not reducible.

Lower-dimensional invariant tori appear, in particular, in perturbed systems of the form (6.46) near a resonance. Suppose that the unperturbed frequencies satisfy r independent resonance relations fixed beforehand, and let I_* be the corresponding resonant value of I . Assume that the variables have already been transformed as in the proof of Theorem 6.15: $\varphi = (\gamma, \chi)$, $\gamma \in \mathbb{T}^r$, $\chi \in \mathbb{T}^{n-r}$, so that $\dot{\gamma} = 0$ under the resonance relations in the unperturbed system; in the perturbed motion near the resonance the phases χ are fast and the phases γ are semifast. The Hamiltonian averaged over the fast phases has the form

$$\mathcal{H} = H_0(I) + \varepsilon \mathcal{H}_1(I, \gamma), \quad \mathcal{H}_1 = \langle H_1 \rangle_{\varepsilon=0}^{\chi}. \quad (6.68)$$

We can further simplify this Hamiltonian by expanding it in the deviations $I - I_*$ and keeping the principal terms. Let $I^{(1)}$ denote the first r components of $I - I_*$, and $I^{(2)}$ the remaining $n - r$ components. Keeping the terms linear in ε , $I^{(2)}$ and quadratic in $I^{(1)}$ we obtain a Hamiltonian of the form

$$\mathcal{H} = (\omega_*, I^{(2)}) + E, \quad E = \frac{1}{2}(A_* I^{(1)}, I^{(1)}) + \varepsilon V(\gamma). \quad (6.69)$$

For $I^{(1)}$, γ we have obtained the system with Hamiltonian E having r degrees of freedom. Suppose that $I^{(1)} = 0$, $\gamma = \gamma_*$ is an equilibrium position of this system. In the phase space $\{(I, \gamma, \chi)\}$ of the Hamiltonian (6.69), to this equilibrium there corresponds an invariant torus T_* . Suppose that the following conditions hold: the frequencies ω_* are strongly incommensurable, the matrix $(\partial^2 H_0 / \partial I^2)_{I_*}$ is non-singular, and the equilibrium $(0, \gamma_*)$ of the system with Hamiltonian E is hyperbolic (note that the eigenvalues attached to this equilibrium are quantities of order $\sqrt{\varepsilon}$). Then the system with the full Hamiltonian (6.46) has an invariant $(n - r)$ -dimensional torus close to the torus T_* and carrying the conditionally periodic motions with frequency vector ω_* ; this torus is hyperbolic and its “whiskers” are close to the “whiskers” of the torus T_* ; see [584].⁴⁰ These “whiskers” play an important role in the mechanism of diffusion of the slow variables in nearly integrable systems discovered in [8] (see also § 6.3.4). Another method for constructing such “whiskered” tori was proposed in [393]. The question whether in the typical situation to *non-hyperbolic* equilibria of the Hamiltonian (6.69) there correspond invariant tori of the full Hamiltonian (for most of the values of the perturbation parameter) was solved in the affirmative in [175, 193, 378, 379] (the case $r = 1$ was considered earlier in [173]). The break-up of resonant tori into finite collection of lower-dimensional tori was considered also in [242, 243, 253].

All the results on lower-dimensional tori discussed above can be carried over to Hamiltonian systems periodically depending on time and to symplectic diffeomorphisms. Some results can be carried over to Hamiltonian systems depending on time conditionally periodically.

If in a Hamiltonian system the 2-form ω^2 defining the symplectic structure is not exact, then this system can have invariant tori on which the motion is conditionally periodic and non-resonant and whose dimension is *greater*

⁴⁰ This assertion is close to being a consequence of Theorem 6.26, but that it is not. Von Zeipel’s method (§ 6.2.2.B) allows one to consider the terms discarded in averaging as a perturbation, and the function (6.68) as the unperturbed Hamiltonian. In contrast to the situation of Theorem 6.26, this unperturbed Hamiltonian itself contains a small parameter ε , and the characteristic exponents of the invariant torus of this Hamiltonian tend to 0 like $\sqrt{\varepsilon}$ as $\varepsilon \rightarrow 0$. For $r = n - 1$ the assertion that to non-degenerate (not necessarily hyperbolic) equilibria of the Hamiltonian (6.69) there correspond periodic solutions of the original Hamiltonian (6.46) is a classical result of Poincaré [41], which is not a part of KAM theory. The case $r = 1$ was considered in detail in the papers [172, 226, 522], which followed [584].

than the number of degrees of freedom. Parasyuk and, independently, Herman developed perturbation theory for such tori (see the corresponding references in [17]). Both the unperturbed and perturbed tori in the Parasyuk–Herman theory are *coisotropic*, that is, the tangent space to the torus at any point contains its skew-orthogonal complement (in the sense of the form ω^2).

The most interesting consequence of the Parasyuk–Herman theory is counterexamples to the so-called *quasi-ergodic hypothesis*: a generic Hamiltonian system is quasi-ergodic on typical connected components of the energy levels. Recall that a measure-preserving dynamical system (not necessarily a Hamiltonian one) is said to be ergodic if each invariant set of this system has either measure zero or full measure, and quasi-ergodic if this system has an everywhere dense trajectory.

It follows from Kolmogorov’s Theorem 6.16 that the so-called *ergodic hypothesis* – that a generic Hamiltonian system is ergodic on typical connected components of the energy levels⁴¹ – is false for any number of degrees of freedom $n \geq 2$. Indeed, each energy-level manifold M of any sufficiently small perturbation of an isoenergetically non-degenerate completely integrable Hamiltonian system contains an invariant set K (a union of the Kolmogorov tori) such that $\text{meas } K > 0$ and $\text{meas } (M \setminus K) > 0$. If the perturbation itself is integrable, then for K one can take the union of some of the invariant tori on the level M .

For systems with two degrees of freedom Kolmogorov’s theorem refutes also the quasi-ergodic hypothesis: the two-dimensional invariant tori divide a three-dimensional energy level and obstruct an evolution of the action variables, see § 6.3.3.A. It follows from the Parasyuk–Herman theory that the quasi-ergodic hypothesis does not hold also for any number of degrees of freedom $n \geq 3$ (this observation is due to Herman [615]). The mechanism of “suppression” of evolution is the same: the $(2n - 2)$ -dimensional invariant tori divide a $(2n - 1)$ -dimensional energy level and “lock” the trajectories between them.

Note that in all the counterexamples considered above the systems are not ergodic (or quasi-ergodic) on any energy level.

The question whether the quasi-ergodic hypothesis is valid for Hamiltonian systems with $n \geq 3$ degrees of freedom under the condition that the symplectic structure is exact still remains open. The studies of diffusion in such systems (see § 6.3.4) suggest that the answer to this question is most likely affirmative.

Recently, Huang, Cong, and Li developed the Hamiltonian KAM theory for invariant tori that are *neither isotropic nor coisotropic* [288, 289]. Their results are discussed in detail in [546]. Of course, the symplectic structure in [288, 289] is not exact.

⁴¹ This is one of the variants of the ergodic hypothesis. For a long time the ergodic hypothesis was considered to be quite plausible, especially in the physical literature.

6.3.8 Variational Principle for Invariant Tori. Cantori

An invariant torus of a Hamiltonian system carrying conditionally periodic motions with a given set of frequencies is an extremal of a certain variational principle. We now state this principle found by Percival [498, 499].

To formulate the principle, it is convenient to pass from the Hamiltonian description of motion to the Lagrangian one. Let $H(p, q)$ be the Hamiltonian of a system with n degrees of freedom. Suppose that the relation $r = \partial H(p, q)/\partial p$ allows one to express p as $p = p(r, q)$. Then the change of the quantities q , $r = \dot{q}$ with time is described by Lagrange's equations with the Lagrangian

$$L(q, r) = p \cdot r - H(p, q).$$

Let $\omega \in \mathbb{R}^n$ be the frequency vector of the conditionally periodic motions that are sought for. For any smooth function $f: \mathbb{T}^n\{\vartheta\} \rightarrow \mathbb{R}$ we set

$$D_\omega f = \left. \frac{d}{dt} f(\omega t + \vartheta) \right|_{t=0} = \frac{\partial f}{\partial \vartheta} \omega.$$

Let Σ be a smooth n -dimensional torus in the phase space q, r given by the parametric relations $q = q_\Sigma(\vartheta)$, $r = D_\omega q_\Sigma(\vartheta)$, $\vartheta \bmod 2\pi \in \mathbb{T}^n$. We define a variation of the torus Σ to be a torus close to Σ and given by relations of the form

$$q = q_\Sigma(\vartheta) + \delta q(\vartheta), \quad r = D_\omega q_\Sigma(\vartheta) + D_\omega \delta q(\vartheta).$$

We introduce the functional

$$\Phi_\omega(\Sigma) = \langle L(q_\Sigma(\vartheta), D_\omega q_\Sigma(\vartheta)) \rangle^\vartheta,$$

where the angular brackets denote the averaging over ϑ .

Theorem 6.27 (Variational Principle [498]). *A smooth torus Σ is an invariant torus of the system under consideration carrying conditionally periodic motions with frequency vector ω if and only if this torus is a stationary point of the functional Φ_ω .*

◁ We write down the first variation of the functional

$$\delta \Phi_\omega = \left\langle \frac{\partial L}{\partial q} \delta q + \frac{\partial L}{\partial r} D_\omega \delta q \right\rangle^\vartheta = \left\langle \left(\frac{\partial L}{\partial q} - D_\omega \frac{\partial L}{\partial r} \right) \delta q \right\rangle^\vartheta.$$

In this calculation we used integration by parts and the 2π -periodicity of the functions q_Σ , δq in ϑ .

If the torus Σ is invariant and filled by the conditionally periodic motions $q_\Sigma(\omega t + \vartheta)$, $D_\omega q_\Sigma(\omega t + \vartheta)$, then by Lagrange's equations we have $\delta \Phi_\omega = 0$, that is, this torus is a stationary point of the functional.

Conversely, if $\delta \Phi_\omega = 0$, then $D_\omega \partial L / \partial r - \partial L / \partial q = 0$. Then $q_\Sigma(\omega t + \vartheta)$, $D_\omega q_\Sigma(\omega t + \vartheta)$ is a conditionally periodic solution of the system. ▷

The variational principle stated above enables one to seek the invariant tori as the stationary points of the functional Φ_ω .

According to the famous dictum of Hilbert, “Every problem of the calculus of variations has a solution, provided that the word “solution” is suitably understood” [619]. The Kolmogorov tori are extremals of the variational principle stated above for nearly integrable systems and for frequency vectors ω with strongly incommensurable components. What “solution” has the variational problem posed above for systems far from integrable, or for abnormally commensurable frequencies? At present there is a detailed answer only in the case of two degrees of freedom (Mather [412, 413], Aubry [92]). The solution proved to be a *cantorus*,⁴² or an Aubry–Mather set – an invariant set obtained by embedding into the phase space a Cantor subset of the standard two-dimensional torus.⁴³ The more precise formulations are given below.

For clarity we consider a Hamiltonian system with one and a half (rather than two) degrees of freedom whose Hamiltonian $H(p, q, t)$ has period 2π in time t and in the coordinate q . Suppose that the system has two invariant tori given by the relations $p = p_0$ and $p = p_1 > p_0$. We introduce the Poincaré return map for this system over time 2π :

$$f: \mathbb{R} \times S^1 \rightarrow \mathbb{R} \times S^1, \quad f(p, q) = (f_p, f_q \bmod 2\pi).$$

The map f preserve areas and orientation and leaves invariant the circles $p = p_0$, $p = p_1$ and the annulus Π between them. This map is obtained from the map \tilde{f} of the universal covering of the annulus Π – the strip $\tilde{\Pi} = \{p, q: p_1 \leq p \leq p_2, -\infty < q < \infty\}$:

$$\tilde{f}: \tilde{\Pi} \rightarrow \tilde{\Pi}, \quad \tilde{f}(p, q) = (f_p, f_q),$$

by identifying the values of q that differ by multiples of 2π .

Suppose that $\partial f_q / \partial p > 0$ in the annulus Π ; in this case the map is called a twist map. Let ν_0, ν_1 denote the average displacements of the points of the boundary straight lines of the strip $\tilde{\Pi}$ under the iterations of the map \tilde{f} :

$$\nu_j = \lim_{N \rightarrow \infty} \frac{1}{N} (f_q(p_j, q) + f_q^2(p_j, q) + \dots + f_q^N(p_j, q)), \quad j = 0, 1.$$

Here f_q^r is the r th iteration of the function f_q with the fixed first argument equal to p_0 or p_1 . The limits do exist, are independent of the value of q on the right-hand side, and differ by multiples of 2π from the Poincaré rotation numbers for the corresponding boundary circles of the annulus Π . Since the map is a twist map, we have $\nu_0 < \nu_1$.

Theorem 6.28 ([413]). *For any $\nu \in (\nu_0, \nu_1)$ there exists a map h (not necessarily continuous) of the standard circle S^1 into the annulus Π ,*

$$h = (h_p, h_q \bmod 2\pi): S^1 \setminus \{\vartheta\} \rightarrow \Pi \setminus \{p, q\},$$

⁴² The term “cantorus” was suggested by Percival.

⁴³ The construction of these sets was also outlined by Antonov [69].

such that the rotation of the circle through the angle $2\pi\nu$ induces the given transformation f of the image of the circle: $f(h(\vartheta)) = h(\vartheta + 2\pi\nu)$, and the following properties hold:

- a) the function h_q is non-decreasing,
- b) if ϑ is a continuity point of h_q , then $\vartheta + 2\pi\nu$ and $\vartheta - 2\pi\nu$ are also continuity points,
- c) the function h_p is calculated by the formula $h_p(\vartheta) = g(h_q(\vartheta), h_q(\vartheta + 2\pi\nu))$, where g is a smooth function,
- d) if the number ν is irrational, then the function h_q is not constant on any interval.

The required function h_q is sought as a minimum point of the functional that is the discrete analogue of the functional Φ_ω introduced above. See details in [412, 413].

We consider some consequences of this result. If $\nu = m/n$ is rational, then for any ϑ the point $h(\vartheta) \in \Pi$ under n iterations of the map f is mapped to itself, and on the universal covering of the annulus – the strip $p_0 < p < p_1$, $-\infty < q < \infty$, – the q -coordinate of the point increases by $2\pi m$. The existence of such periodic points is one of the well-known consequences of the Poincaré geometric theorem proved by Birkhoff [14]. In this case the original Hamiltonian system has a periodic solution with period $2\pi n$ that performs m revolutions with respect to the angle q over the period.

If ν is irrational and the map h_q is continuous, then the original Poincaré return map has an invariant curve homeomorphic to a circle and on this curve the return map is topologically conjugate to the rotation of the circle through the angle $2\pi\nu$. The original Hamiltonian system has a two-dimension invariant torus wound round by conditionally periodic motions with frequency ratio ν .

Now suppose that ν is irrational, while h_q is discontinuous. Then the discontinuity points are everywhere dense by part b) of Theorem 6.28. Since h_q is non-decreasing by part a), there are also continuity points, which are also everywhere dense. We denote by Ξ and Σ the closures of the sets of points $h_q(\vartheta) \bmod 2\pi \in S^1$ and $h(\vartheta) \in \Pi$, respectively, such that ϑ is a continuity point of h_q . Then, by parts b)–d) of the theorem, Ξ is a Cantor set on the circle, and Σ is an invariant “cantor-circle” (“one-dimensional cantorus”), the motion on which is characterized by the rotation number ν . To this cantor-circle there corresponds an invariant cantorus of the original Hamiltonian system. There are examples of maps f that have no continuous invariant curves not homotopic to zero [92]. All the invariant sets of such maps corresponding to irrational rotation numbers are cantor-circles.

The cantor-circles found above are unstable. Moreover, the set of trajectories asymptotic to them covers the entire circle under the projection $(p, q) \mapsto q$; see [128].

The discovery of cantor-circles, apparently, explains the following result of numerical investigation of the maps under consideration: during a large number of iterations the point can move in a domain seemingly bounded by

an invariant curve, and then over a relatively small number of iterations the point can cross this curve and start moving in the domain on the other side of this curve. The reason is that, although a cantor-circle does not divide the plane, it may be something like a dense fence which cannot be that easily crossed by the phase point. Therefore the point must move for a long time along this fence before it slips through some chink. Numerically this process was in detail studied in [402].

Later Mather obtained a partial generalization of the Aubry–Mather theory to the multidimensional case. This generalization can be most naturally stated for symplectic maps that are Poincaré maps of positive definite Lagrangian systems. For simplicity we state some results in the language of Hamiltonian systems assuming that the configuration space is the torus \mathbb{T}^n , and the phase space is $\mathbb{T}^n \times \mathbb{R}^n$.

Suppose that the Hamiltonian function $H(q, p, t)$ is periodic in time, strictly convex with respect to the momentum, that is, $H_{pp}(q, p, t)$ is positive definite, and that $H(q, p, t)/|p| \rightarrow \infty$ as $|p| \rightarrow \infty$. This condition is similar to the twist condition of an area-preserving two-dimensional map. It is also assumed that the solutions of Hamilton’s equations can be continued unboundedly, so that the Poincaré map is defined everywhere.

For the function space, instead of the set of maps of the circle into the plane, it is convenient to take the set M of invariant Borel probability measures μ on the extended phase space $\mathbb{T}^n \times \mathbb{R}^n \times \mathbb{T}$. By the Krylov–Bogolyubov theorem, M is non-empty and is a compact metric space. To each invariant measure $\mu \in M$ there corresponds the frequency vector $\omega(\mu) = \int \dot{q} d\mu \in \mathbb{R}^n$. The action functional A on M is defined by

$$A(\mu) = \int (p\dot{q} - H) d\mu.$$

Mather proved that the functional A does attain the minimum on the set of measures with a given frequency vector, and the union of supports of the minimum measures is a compact invariant set uniquely projected onto the extended configuration space. These sets are a generalization of the Aubry–Mather sets.

The simplest example is a KAM-torus for a perturbation of a positive definite integrable system. In this case the minimum measure is the Lebesgue measure on the torus, and $\omega(\mu)$ is the frequency vector for the invariant torus. The action functional A turns into the Percival functional.

Many results of the theory of twist maps were generalized to the multidimensional case [127, 233, 404, 415, 416]. However, there is no simple description of the structure of the Mather sets in the multidimensional case.

Fathi [233] used the method of weak solutions of the Hamilton–Jacobi equation to construct invariant sets generalizing the Mather sets.

6.3.9 Applications of KAM Theory

In many classical problems of mechanics and physics, KAM theory provided a rigorous justification to the conclusions that had been obtained earlier by using the heuristic averaging principle and formal perturbation theory. Here are the best-known (see [10, 36]) examples:

- Suppose that in the problem of the motion of a heavy rigid body with a fixed point (Example 6.14) the kinetic energy of the body is sufficiently large compared to the potential energy (at the initial instant). Then the length of the angular momentum vector and its inclination to the horizon remain forever near their initial values (under the assumption that the initial values of the energy and angular momentum are not close to those for which the body can rotate around the middle inertia axis). For most of the initial conditions the motion of the body will be forever close to a combination of the Euler–Poincot motion and a slow azimuthal precession.

- In the *planar restricted circular three-body problem* (Example 6.13), if the mass of Jupiter is sufficiently small, then the length of the major semiaxis and the eccentricity of the Keplerian ellipse of the asteroid will remain forever close to their initial values (if at the initial instant this ellipse does not intersect Jupiter’s orbit). For most of the initial conditions the motion is forever close to the Keplerian motion in an ellipse which slowly rotates around its focus.

- In the *n-body problem* (Example 6.16), if the masses of the planets are sufficiently small, then a larger part of the domain of the phase space corresponding to the unperturbed motion in one direction in Keplerian ellipses with small eccentricities and inclinations is filled with conditionally periodic motions close to the Lagrangian motions.

- Most of the geodesics on a surface close to a triaxial ellipsoid oscillate between two closed lines that are close to the curvature lines of the surface, and these geodesics fill the annulus between these two lines everywhere densely. This annulus is the projection onto the configuration space (that is, the surface under consideration) of an invariant torus in the phase space which is filled by a trajectory of the problem.

- There exists a magnetic field most of whose force lines in a neighbourhood of a given circle wind round nested toroidal surfaces surrounding this circle; the remaining force lines are forever trapped between these toroidal surfaces. Under a small perturbation of the field, most of these “magnetic surfaces” are not destroyed but merely slightly deformed. (Such a configuration of the field is used for confining plasma within a toroidal chamber.) The first to point out such a magnetic surface was Tamm in his “Fundamentals of electricity theory”, 1929 (Russian).

The assertion on the stability of an equilibrium position of a system with two degrees of freedom in the general elliptic case also has numerous applications.

Example 6.23 (Stability of triangular libration points). The planar restricted circular three-body problem in the rotating coordinate system of Exam-

ple 6.13 has two degrees of freedom. The *triangular libration points* are equilibrium positions of this system [408]. These equilibrium positions, as was already known to Lagrange, are stable in the linear approximation if $\mu < \mu_1 = \frac{1}{2} (1 - \frac{1}{9}\sqrt{69}) \approx 0.03852$, and unstable otherwise (here $\mu/(1 - \mu)$ is the ratio of Jupiter’s mass to the mass of the Sun, and we assume that $\mu < 1/2$). It turns out [206] that to resonances of order ≤ 4 there correspond the values

$$\begin{aligned} \mu = \mu_2 &= \frac{1}{2} \left(1 - \frac{1}{45} \sqrt{1833} \right) \approx 0.02429, \\ \mu = \mu_3 &= \frac{1}{2} \left(1 - \frac{1}{15} \sqrt{213} \right) \approx 0.01352. \end{aligned}$$

Furthermore, it turns out [206] that the condition of isoenergetic non-degeneracy is violated for the only value $\mu = \mu_c \approx 0.0109$ (first it was proved that the problem is degenerate only at finitely many points [376], and then the critical value μ_c was calculated).

According to the result of § 6.3.3, for $0 < \mu < \mu_1$ and $\mu \neq \mu_2, \mu_3, \mu_c$ the triangular libration points are stable. In [408] it was shown that for $\mu = \mu_2$ and $\mu = \mu_3$ instability takes place, and for $\mu = \mu_c$ stability. In [563] it was shown that for $\mu = \mu_1$ we have stability. △

Stability of stationary rotations of a heavy rigid body around a fixed point has been studied in similar fashion [319].

We now state some results following from the assertions on the stability of an equilibrium of a system with one degree of freedom periodically depending on time, of a periodic motion of a system with two degrees of freedom, and of a fixed point of a symplectic map of the plane:

- If an equilibrium of a pendulum in a field periodically depending on time is stable in the linear approximation, and among its multipliers there are no points of the unit circle with arguments $\pi j/3, \pi j/4$ for $j = 0, 1, \dots, 7$, then the equilibrium is stable.

- If a closed geodesic on a generic surface in a three-dimensional space is stable in the linear approximation, then it is stable.

- If the trajectory of a ball bouncing between two generic concave walls (or, which is the same, of a ray of light reflecting from mirrors; Fig. 6.29) is stable in the linear approximation, then it is stable.

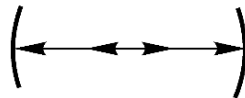

Fig. 6.29.

The lower-dimensional invariant tori (§ 6.3.7) are encountered in a number of problems.

Example 6.24. Keeping a space station in orbit near the collinear libration point L_1 or L_2 of the restricted circular three-body problem (§ 2.5.2) proved to be important for a number of projects of space exploration (including also some already realized). In these projects the role of massive attracting centres is played by the Sun and the Earth (more precisely, the system Earth + Moon), or the Earth and the Moon. From the collinear libration point there branches off a family of planar periodic orbits called the Lyapunov family (this family is provided by Theorem 7.16). From one of the orbits of the Lyapunov family whose period is equal to the period of small oscillations across the plane of the orbit there branches off a family of spatial periodic orbits called *halo orbits*. The collinear libration point, and the orbits of the nearby Lyapunov family, and the halo orbits near the point where their family branches off are unstable. However, the control for keeping the space station in these orbits does not require a large amount of fuel. For this control it is sufficient to return the station not to the periodic orbit itself but to an attracting “whisker” of it (attracting invariant manifold). The influence of the other planets of the Solar System (whose motion can be considered to be conditionally periodic), of the eccentricities of the orbits of the Earth and the Moon, and of the light pressure turn the periodic orbit into a conditionally periodic one lying on a lower-dimensional invariant torus. For the control it is sufficient to bring the station back onto an attracting “whisker” of the torus. These topics are dealt with in many papers; see, in particular, [143, 221, 222, 231, 232, 262, 296, 384, 408] and the references therein. \triangle

Applications of KAM theory to the problem of perpetual conservation of adiabatic invariants are described in § 6.4.

Less traditional applications relate to the calculation of the short-wave approximation for the eigenvalues and eigenfunctions of the Schrödinger, Laplace, and Beltrami–Laplace operators [33, 370]. For definiteness we discuss the case of the Schrödinger operator. The formulae of short-wave approximation allow one to use the solutions of the equations of motion of a classical mechanical system for constructing approximate solutions of the Schrödinger equation describing the behaviour of the corresponding quantum system. In particular, if the phase space of the classical system contains an invariant torus satisfying arithmetic quantization conditions, then the formulae of short-wave approximation enable one to use this torus for constructing the asymptotics of the eigenvalue of the Schrödinger operator and of the corresponding almost-eigenfunction.⁴⁴ In a nearly integrable system there are many invariant tori, and they form a smooth family (§ 6.3.2). Correspondingly, generally speaking, there are many tori satisfying the quantization conditions. This allows one to approximate most of the spectrum of the corresponding Schrödinger operator.

⁴⁴ An almost-eigenfunction approximately satisfies the equation for an eigenfunction, but can be far from the latter.

6.4 Adiabatic Invariants

In this section we describe the effect of a slow change of the parameters on the motion in an integrable Hamiltonian system. An *adiabatic invariant* of such a system is by definition a function of the phase variables and parameters which changes little for a considerable change of the parameters. The main rigorously proved results of the theory relate to single-frequency systems.

6.4.1 Adiabatic Invariance of the Action Variable in Single-Frequency Systems

We consider a Hamiltonian system with one degree of freedom whose parameters change slowly; the Hamiltonian is $E = E(p, q, \lambda)$, where $\lambda = \lambda(\tau)$, $\tau = \varepsilon t$, $0 < \varepsilon \ll 1$ (for example, a pendulum with slowly changing length). The function $\lambda(\tau)$ is assumed to be sufficiently smooth.

Definition 6.1. A function $I(p, q, \lambda)$ is called an *adiabatic invariant* if for any $\varkappa > 0$ there exists $\varepsilon_0 = \varepsilon_0(\varkappa)$ such that for $\varepsilon < \varepsilon_0$ the change of $I(p(t), q(t), \lambda(\varepsilon t))$ for $0 \leq t \leq 1/\varepsilon$ does not exceed \varkappa .⁴⁵

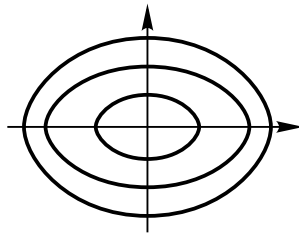

Fig. 6.30.

Suppose that for each fixed λ the Hamiltonian function $E(p, q, \lambda)$ has closed phase curves (say, encircling an equilibrium position of the pendulum; Fig. 6.30) on which the frequency of the motion is non-zero. Then there is a smooth transformation introducing action-angle variables of the system with fixed λ :

$$I = I(p, q, \lambda), \quad \varphi = \varphi(p, q, \lambda) \pmod{2\pi}.$$

Our nearest goal is to prove the adiabatic invariance of the quantity I . The following proposition is obvious.

⁴⁵ Such almost-conserved quantities were first discovered by Boltzmann when he considered adiabatic processes in thermodynamics. The term “adiabatic invariant” was introduced by Ehrenfest. There have been many different definitions of adiabatic invariance. The above definition, which has now become generally accepted, was given by Andronov, Leontovich, Mandel’shtam. See a detailed exposition of the history of the question in [95].

Proposition 6.3. *The variation of the variables I, φ in the system with a slowly changing parameter is described by the Hamiltonian $H = H_0(I, \lambda) + \varepsilon H_1(I, \varphi, \varepsilon t)$:*

$$\dot{I} = -\varepsilon \frac{\partial H_1}{\partial \varphi}, \quad \dot{\varphi} = \frac{\partial H_0}{\partial I} + \varepsilon \frac{\partial H_1}{\partial I}, \quad (6.70)$$

where H_0 is the Hamiltonian E expressed in terms of I and λ , and H_1 has period 2π in φ .

The summand H_1 appears because the canonical transformation to the action-angle variables depends on time, and the factor ε in front of H_1 appears because the parameter varies slowly, $\lambda = \lambda(\varepsilon t)$.

The form of equations (6.70) is standard for applying the averaging principle of § 6.1.1.

Proposition 6.4. *The action variable I is an integral of the system averaged over the phase.*

◁ The right-hand side of the equation for I is the derivative of a periodic function and therefore has mean value zero. ▷

Theorem 6.29. *If the frequency $\omega(I, \lambda)$ of the system with one degree of freedom does not vanish, then the action variable $I(p, q, \lambda)$ is an adiabatic invariant:*

$$|I(p(t), q(t), \lambda(\varepsilon t)) - I(p(0), q(0), \lambda(0))| < c\varepsilon$$

for $0 \leq t \leq \frac{1}{\varepsilon}, \quad c = \text{const} > 0.$

◁ By Theorem 6.1 in § 6.1, the averaging principle describes the solutions of a single-frequency system with an accuracy of order ε over time $1/\varepsilon$, and I is an integral of the averaged system. ▷

Example 6.25. For a harmonic oscillator the ratio $I = h/\omega$ of the energy to the frequency is an adiabatic invariant. △

Suppose that in a Hamiltonian system with $n \geq 2$ degrees of freedom the Hamiltonian E depends slowly on all the coordinates, except for one of them (which we denote by q): $E = E(p, q, y, \varepsilon \hat{x})$, where q, \hat{x} are coordinates, and p, y their conjugate momenta.⁴⁶

We set $x = \varepsilon \hat{x}$. The variation of the variables p, q, y, x is described by the equations

$$\dot{p} = -\frac{\partial E}{\partial q}, \quad \dot{q} = \frac{\partial E}{\partial p}, \quad \dot{y} = -\varepsilon \frac{\partial E}{\partial x}, \quad \dot{x} = \varepsilon \frac{\partial E}{\partial y}, \quad (6.71)$$

$$E = E(p, q, y, x).$$

⁴⁶ The slow dependence of the Hamiltonian on time reduces to this case by introducing time as a new coordinate and adding its conjugate momentum.

This is a Hamiltonian system of equations with respect to the symplectic structure $dp \wedge dq + \varepsilon^{-1}dy \wedge dx$. In system (6.71) the variables p, q are called fast, and the variables y, x slow; system (6.71) itself is called a system with slow and fast variables or a slow-fast system.⁴⁷ An adiabatic invariant of such a system is a function of the phase variables whose variation is small on times $1/\varepsilon$. The system with one degree of freedom in which $x = \text{const}$, $y = \text{const}$ is called unperturbed or fast. Suppose that the phase portrait of the unperturbed system contains closed trajectories (Fig. 6.30) on which the frequency of the motion is non-zero, so that we can introduce action-angle variables

$$I = I(p, q, y, x), \quad \varphi = \varphi(p, q, y, x) \pmod{2\pi}.$$

We denote by $H_0(I, y, x)$ the Hamiltonian E expressed in terms of I, y, x .

Theorem 6.30. *The action variable I is an adiabatic invariant of the system with Hamiltonian $E(p, q, y, x)$. The variation of the variables y, x is described with an accuracy of order ε on the time interval $1/\varepsilon$ by the system with Hamiltonian $H_0(I, y, x)$ containing I as a parameter (this approximation is called adiabatic).*

◁ Let $S(I, q, y, x)$ denote the generating function of the canonical transformation $(p, q) \mapsto (I, \varphi)$. Consider the canonical transformation $(p, q, y, x) \mapsto (\bar{I}, \bar{\varphi}, Y, X)$ defined by the generating function $\varepsilon^{-1}Yx + S(I, q, Y, x)$. The conjugate pairs of the old canonical variables are (p, q) and $(y, \varepsilon^{-1}x)$, and of the new canonical variables, $(\bar{I}, \bar{\varphi})$ and $(Y, \varepsilon^{-1}X)$. Then $y = Y + O(\varepsilon)$, $x = X + O(\varepsilon)$, $I = \bar{I} + O(\varepsilon)$, $\varphi = \bar{\varphi} + O(\varepsilon)$. The variation of the new variables is described by the Hamiltonian

$$H = H_0(\bar{I}, Y, X) + \varepsilon H_1(\bar{I}, \bar{\varphi}, Y, X, \varepsilon).$$

Averaging over the phase $\bar{\varphi}$ we obtain a system describing the variation of the slow variables with an accuracy of order ε on times $1/\varepsilon$. The action \bar{I} is an integral of this system. ▷

Remark 6.21. If the original system has two degrees of freedom, then Theorem 6.30 produces a system with one degree of freedom and the averaged equations can be integrated.

Remark 6.22. The same quantity I is an adiabatic invariant of any system with the Hamiltonian $F = E(p, q, y, x) + \varepsilon E_1(p, q, y, x, \varepsilon)$.

⁴⁷ In the previous editions of this book we did not introduce the notation $x = \varepsilon \hat{x}$. The notation adopted here is convenient because the variables y and x possess equal rights.

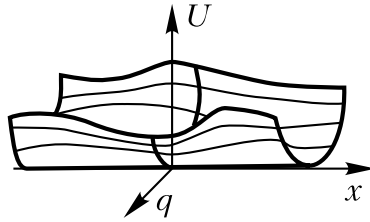

Fig. 6.31.

Example 6.26. For the motion in a quadratic *potential trough* stretched along the \hat{x} -axis (Fig. 6.31) we have

$$E = \frac{p^2 + y^2 + \omega^2(x)q^2}{2}, \quad I = \frac{p^2 + \omega^2(x)q^2}{2\omega(x)},$$

$$H_0 = \frac{y^2}{2} + I\omega(x), \quad x = \varepsilon\hat{x}.$$

The symplectic structure is $\Omega^2 = dp \wedge dq + \varepsilon^{-1}dy \wedge dx$.

For example, suppose that the function $\omega(x)$ is even and, as $|x|$ increases, first increases and then decreases (Fig. 6.32a). The phase portrait of the system with Hamiltonian H_0 is shown in Fig. 6.32b. One can see that for not too high initial longitudinal velocity, the point is trapped in the middle part of the trough (Fig. 6.32c). The corresponding condition on the velocity (the “trapping condition”) is usually written in the form

$$\frac{E_{\parallel}}{E_{\perp}} < \frac{\omega_m - \omega_0}{\omega_0}, \tag{6.72}$$

where $E_{\parallel} = y^2/2$ and $E_{\perp} = (p^2 + \omega^2 q^2)/2$ are the values of the energy of the longitudinal and transverse motions of the point in the middle of the trough (for $x = 0$), while ω_0 and ω_m are the minimum and maximum values of the function $\omega(x)$, respectively.

The validity of these conclusions over times $1/\varepsilon$ follows from Theorem 6.30. They can be extended to infinite times by using KAM theory (see § 6.4.6).

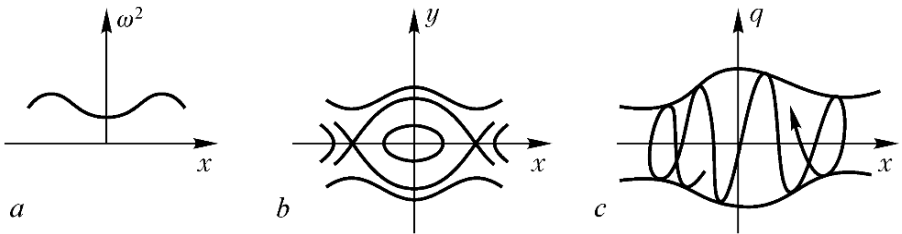

Fig. 6.32.

△

Example 6.27. Short-wave excitation propagates along rays. A *waveguide* is a potential trough for rays. A slowly irregular refractive waveguide is a medium whose refraction index varies slowly along some curve (the axis of the waveguide), and fast in the transversal directions to the axis; on the axis of the waveguide the refraction index has maximum value. For example, suppose that the axis of a waveguide is a straight line, and the medium is two-dimensional (Fig. 6.33). Then the propagation of rays is described by the system with Hamiltonian

$$E = p^2 + y^2 - n^2(q, x), \quad x = \varepsilon \hat{x},$$

where \hat{x} is a coordinate along the axis of the waveguide, the q -axis is perpendicular to it, the momenta y, p define the direction of a ray, and n^2 is the refraction index [359]. Solutions of this system must be considered on the energy level $E = 0$.

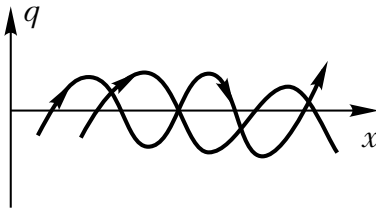

Fig. 6.33.

Near the axis the refraction index can be assumed to be quadratic: $n^2 = a^2(x) - b^2(x)q^2$. Then in the notation of Theorem 6.30 we have

$$I = \frac{p^2 + b^2 q^2}{2b}, \quad H_0 = y^2 - a^2(x) + 2Ib(x).$$

These relations allow one to describe the behaviour of rays. The ray picture is shown in Fig. 6.33 (for the case where there is no “trapping” of rays such as in Example 6.26). This method is used to describe the propagation of light in optical waveguides, propagation of short radiowaves and of sound in stratified media [359]. \triangle

Example 6.28. In a constant magnetic field a charged particle moves in a spiral around a force line of the field. This motion is the composition of rotation around the field line (along a circle, which is called the Larmor circle) and a drift of this circle (Fig. 6.34).

In the case where the relative change of the field is small over distances of order of the Larmor radius and the pitch of the spiral (a slowly non-uniform or, in another normalization, a strong magnetic field), the dynamics of the particle is described by the adiabatic approximation constructed below (in plasma physics this approximation is also called the guiding-centre theory).

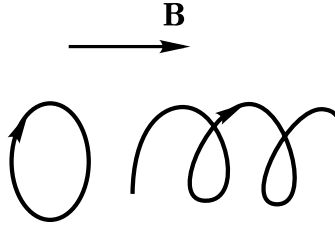

Fig. 6.34.

The motion of a particle in a slowly non-uniform magnetic field is described by the Hamiltonian system with Hamiltonian $E = \frac{1}{2m}(p, p)$ with respect to the symplectic structure

$$\begin{aligned} \Omega^2 &= dp \wedge d\hat{q} - \hat{\Gamma}^2, \quad \text{where} \\ dp \wedge d\hat{q} &= dp_1 \wedge d\hat{q}_1 + dp_2 \wedge d\hat{q}_2 + dp_3 \wedge d\hat{q}_3, \\ \hat{\Gamma}^2 &= \frac{e}{c} \sum_{i < j} \Gamma_{ij}(\varepsilon\hat{q}) d\hat{q}_i \wedge d\hat{q}_j. \end{aligned}$$

Here $\hat{q} = (\hat{q}_1, \hat{q}_2, \hat{q}_3)$ and $p = (p_1, p_2, p_3)$ are the Cartesian coordinates and momenta of the particle, respectively; $\hat{\Gamma}^2$ is a closed differential 2-form, $\Gamma_{12} = -B_3$, $\Gamma_{13} = B_2$, $\Gamma_{23} = -B_1$; $B(\varepsilon\hat{q}) = (B_1, B_2, B_3)$ is the magnetic field strength, $B \neq 0$; m, e are the mass and the charge of the particle, c is the speed of light; (\cdot, \cdot) is the standard scalar product, and $0 < \varepsilon \ll 1$. The condition $\text{div } B = 0$ ensures that the form $\hat{\Gamma}^2$ is closed. Setting $q = \varepsilon\hat{q}$ we obtain the symplectic structure

$$\Omega^2 = \varepsilon^{-1} dp \wedge dq - \varepsilon^{-2} \Gamma^2, \quad \Gamma^2 = \frac{e}{c} \sum_{i < j} \Gamma_{ij}(q) dq_i \wedge dq_j.$$

By Darboux’s theorem for odd-dimensional spaces ([10], Appendix 4) there exists (locally) a change of variables $q = f(\tilde{q})$ such that the form Γ^2 becomes $\Gamma^2 = d\tilde{q}_1 \wedge d\tilde{q}_2$. For this choice of coordinates the lines $\{\tilde{q}_1 = \text{const}, \tilde{q}_2 = \text{const}\}$ are the magnetic field lines. We set $\tilde{p} = p \partial f / \partial \tilde{q}$. In the variables (\tilde{p}, \tilde{q}) the symplectic structure takes the form (we omit tilde over the new variables)

$$\Omega^2 = \varepsilon^{-1} dp \wedge dq - \varepsilon^{-2} dq_1 \wedge dq_2.$$

The Hamiltonian E is a positive definite quadratic form in p with coefficients depending on q : $E = \frac{1}{2}(A(q) p, p)$.

Instead of q_1, q_2 we introduce new variables Q_1, Q_2 by the formulae

$$q_1 = Q_1 + \varepsilon p_2, \quad q_2 = Q_2 - \varepsilon p_1.$$

This transformation is called a *guiding-centre* transformation. Setting $P = (p_1, p_2)$, $Q = (Q_1, Q_2)$ we obtain

$$E = \frac{1}{2}(A(Q, q_3) p, p) + \varepsilon E_1(P, Q, p_3, q_3, \varepsilon),$$

$$\Omega^2 = \varepsilon^{-1} dp_3 \wedge dq_3 + dp_1 \wedge dp_2 + \varepsilon^{-2} dQ_2 \wedge dQ_1.$$

The form Ω^2 has the canonical form (§ 1.3.1), in which the conjugate pairs of coordinates and momenta now are (p_2, p_1) , $(\varepsilon^{-1} q_3, p_3)$, $(\varepsilon^{-1} Q_1, \varepsilon^{-1} Q_2)$.

The variables (p_2, p_1) change with rate of order 1 (this is the Larmor motion), the variables (q_3, p_3) change with rate of order ε (their variation describes the drift along a force line of the field), the variables (Q_1, Q_2) change with rate of order ε^2 (this is the drift across the field lines).

Let $P = C(Q, q_3) p_3$ be the minimum point of the quadratic form $\frac{1}{2}(Ap, p)$ with respect to P with the other variables fixed. Then the Hamiltonian can be represented in the form

$$E = E_0(P, Q, p_3, q_3) + \varepsilon E_1(P, Q, p_3, q_3),$$

$$E_0 = \frac{1}{2} \left(D(Q, q_3) (P - C(Q, q_3) p_3), P - C(Q, q_3) p_3 \right) + \frac{1}{2} d(Q, q_3) p_3^2.$$

According to Theorem 6.30 and Remark 6.22 after it, the system has an adiabatic invariant I – the “action” of the linear system for the variables P with Hamiltonian E_0 considered for fixed values of the other variables. The behaviour of the variables p_3, q_3 in the adiabatic approximation is described by the system with the Hamiltonian

$$E_0 = \omega(Q, q_3) I + \frac{1}{2} d(Q, q_3) p_3^2. \quad (6.73)$$

Here the conjugate canonical variables are p_3 and $\varepsilon^{-1} q_3$, while $\omega = \frac{e}{mc} |B|$ is the frequency of the Larmor motion. In this approximation the quantities Q are considered to be constant. If the behaviour of the variables p_3, q_3 in this approximation is periodic,⁴⁸ then the “action” corresponding to this motion is approximately preserved on times $\sim 1/\varepsilon^2$ (the so-called second, or longitudinal adiabatic invariant of motion in a magnetic field), and the behaviour of the variables Q on such times can be studied by using the corresponding adiabatic approximation. From (6.73) and the formula for the Larmor frequency we obtain that $I = \frac{mc}{e} \frac{E_\perp}{|B|}$, where E_\perp is the energy of the Larmor motion. Thus, the quantity $\mu = E_\perp/|B|$ (the magnetic moment⁴⁹) is an adiabatic invariant.

⁴⁸ One should bear in mind that the variables (p, q) are provided by Darboux’s theorem; these variables, generally speaking, are defined locally.

⁴⁹ The magnetic moment is proportional to the flux of the magnetic field through the Larmor disc.

The theory of motion in a slowly non-uniform magnetic field was described in [482] without using the Hamiltonian formalism; the Hamiltonian theory was developed in [244, 389]. A multidimensional generalization of the guiding-centre theory is contained in [132].

We now consider the special case where the magnetic field is directed along the q_3 axis: $B_1 = B_2 = 0$. Then $B_3 = B_3(q_1, q_2)$, and in formula (6.73) we have $d = 1$, $\omega = \omega(Q_1, Q_2)$. The quantity p_3 is an integral of the motion; in what follows we assume that $p_3 = 0$. To critical points of the function ω there correspond periodic trajectories of the Hamiltonian E_0 of the adiabatic approximation – Larmor circles which are not drifting. If a critical point is non-degenerate, then the original problem has a periodic trajectory close to the corresponding Larmor circle (according to Theorem 6.4 in §6.1). Suppose that the magnetic field is periodic in q_1, q_2 , so that the motion can be regarded as taking place on a torus. A smooth function on a torus has at least four critical points (counting multiplicities), including at least three geometrically distinct. Thus, the consideration of the adiabatic approximation predicts the existence in the original problem of at least four periodic trajectories (counting multiplicities), including at least three geometrically distinct. This prediction proves to be true even without the assumption of the smallness of the parameter ε ; see [82] (and [29, 78, 258]).

We now consider another special case where a slowly non-uniform field is axially symmetric and its field lines lie in the planes passing through the symmetry axis (Fig. 6.35). In cylindrical coordinates r, ϑ, z the Hamiltonian and the coefficients of the symplectic structure are independent of the angle ϑ .

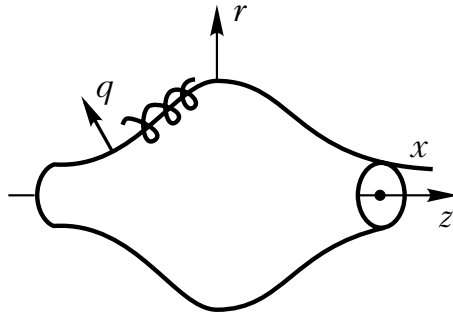

Fig. 6.35.

Here the problem reduces to two degrees of freedom and its study in the adiabatic approximation can be carried out to its conclusion. The Hamiltonian of the adiabatic approximation has the form

$$E_0 = \frac{y^2}{2m} + I\omega(x),$$

where $\varepsilon^{-1}x$ is the arc length of a force line of the field, and y is its conjugate momentum. The trapping condition (6.72) shows which particles are trapped in the potential trough around the field line. This principle of confining charged particles is a basis for constructing *traps* for plasma, which are called adiabatic [482] (or traps with magnetic mirrors). The magnetic field of the Earth is a gigantic natural adiabatic trap (Fig. 6.36).

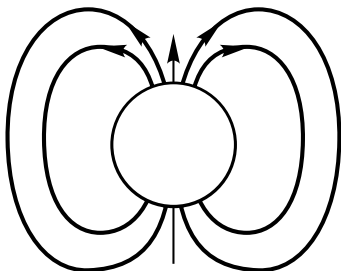

Fig. 6.36.

△

Example 6.29 (Geodesic and Gaussian curvatures as adiabatic invariants). Adiabatic invariants of motion in a magnetic field lead to remarkable geometric facts about curves of a given large geodesic curvature $B(q)$ on a surface with a Riemannian metric of Gaussian curvature $K(q)$. In the first approximation such a curve is a “Larmor” circle of radius $1/B$. But in the next approximation its centre starts drifting along a level line of the adiabatic invariant B . If, however, $B = 1/\varepsilon$ is a constant, then the Gaussian curvature K proves to be an adiabatic invariant, so that a curve of geodesic curvature $1/\varepsilon$ is a spiral coiling in a narrow strip around a level line of the Gaussian curvature. △

Adiabatic invariants also exist in systems with impacts.

Example 6.30. When a small elastic ball moves between two slowly moving walls (Fig. 6.37), an adiabatic invariant is the product of the speed of the ball and the distance between the walls. This fact can be established by a straightforward calculation, or it can be extracted from Theorem 6.29 by passing to the limit.

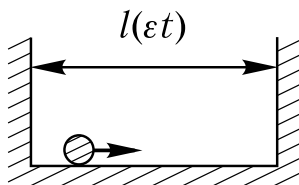

Fig. 6.37.

△

Example 6.31 ([359]). When rays propagate in a planar slowly irregular⁵⁰ *optical waveguide* with mirror walls (Fig. 6.38), an adiabatic invariant is the product of the distance between the walls and the sine of the angle between the ray and the wall.



Fig. 6.38.

△

In Examples 6.30, 6.31 the problem reduces to studying iterations of the near-identity symplectic map $(x, y) \mapsto (X, Y)$ defined by the generating function $xY + \varepsilon S(x, Y, \varepsilon)$:

$$X = x + \varepsilon \frac{\partial S}{\partial Y}, \quad y = Y + \varepsilon \frac{\partial S}{\partial x}.$$

Clearly, $S(X, Y, 0) = S(x, y, 0) + O(\varepsilon^2)$, that is, after one iteration of the map the value of the function $S(x, y, 0)$ is preserved with an accuracy $O(\varepsilon^2)$. Hence the function $S(x, y, 0)$ is an adiabatic invariant: over $\sim 1/\varepsilon$ iterations of the map the value of this function along a discrete trajectory of the phase point is preserved with an accuracy $O(\varepsilon)$.

6.4.2 Adiabatic Invariants of Multi-Frequency Hamiltonian Systems

Definition 6.2. A function of the phase coordinates and parameters is called an *almost adiabatic invariant* if for any $\rho > 0$ the measure of the set of initial conditions for which the change of this function along the solution is greater than ρ over time $1/\varepsilon$ tends to zero as $\varepsilon \rightarrow 0$.

We consider a Hamiltonian system with $n \geq 2$ degrees of freedom whose Hamiltonian depends on a slowly changing parameter λ . Suppose that for each fixed λ the system is completely integrable, so that we can introduce action–angle variables I, φ . For this system Propositions 6.3 and 6.4 of § 6.4.1 hold (the proof is exactly the same): the variation of I, φ is described by a system of the form (6.70), and the “actions” I are integrals of the averaged system. How do the variables I behave in the exact system?

Suppose that $\det(\partial^2 H_0 / \partial I^2) \neq 0$. Then by Theorem 6.11 the changes of the quantities I remain smaller than $\rho > 0$ over time $1/\varepsilon$ if we neglect a

⁵⁰ An optical waveguide is called slowly irregular if its width and direction of the walls vary slowly along the waveguide.

set of initial conditions of measure $c\sqrt{\varepsilon}/\rho$, $c = \text{const} > 0$, in the phase space (which is assumed here to be compact). Thus, the action variables I are almost adiabatic invariants of the non-degenerate multi-frequency Hamiltonian system.

If the system has two frequencies, then the estimate of the change of the variables I can be sharpened by the results of § 6.1.6.⁵¹

Examples show that even in a two-frequency system there may exist a set of initial conditions of measure $\sqrt{\varepsilon}$ for which an almost adiabatic invariant changes by a quantity of order 1 over time $1/\varepsilon$ due to capture into resonance [94]. Adiabatic invariance in single-frequency systems is conserved for a far longer time than $1/\varepsilon$, and if the parameter λ varies periodically, then even forever (see § 6.4.6). In multi-frequency systems the picture is completely different. Examples show that for a set of initial conditions of measure of order 1 an almost adiabatic invariant may change by 1 over time $1/\varepsilon^{3/2}$ due to temporary captures into resonance [460, 461]. General results of [213] provide also examples where such destruction of the adiabatic invariance is caused by multiple passages through a resonance without capture. The motion near a resonance and, in particular, the motion of phase points captured into resonance is described by using the Hamiltonian version of the procedure of § 6.1.7; see [461, 463, 464]. (For example, this procedure was used in [295] in the problem of the so-called *surfatron acceleration* of charged particles.)

Above we have been assuming that the system is completely integrable for each fixed λ . An almost adiabatic invariant also exists in the opposite, far more prevalent case where the motion is ergodic on almost all energy levels $E(p, q, \lambda) = \text{const}$ for almost each λ . Suppose that the surface $E(p, q, \lambda) = h$ is smooth and bounds a finite phase volume.⁵² We denote this volume by $I(h, \lambda)$. The function $I(E(p, q, \lambda), \lambda)$ is an almost adiabatic invariant [305]. An analogous assertion is valid for slow-fast Hamiltonian systems. The Hamiltonian of such a system has the form $E = E(p, q, y, x)$ with fast variables p, q and slow variables y, x (cf. (6.71)). Assume that for almost all frozen values of the slow variables the dynamics of the fast variables is ergodic on almost all the energy levels $E(p, q, y, x) = \text{const}$. Suppose that the surface $E(p, q, y, x) = h$ is smooth and bounds a finite volume.⁵³ We denote this volume by $I(h, y, x)$. The results of [66] imply that the function $I(E(p, q, y, x), y, x)$ is an almost adiabatic invariant and that the dynamics of the slow variables for most of the initial conditions is approximately described by the Hamiltonian system with the Hamiltonian $H_0(I, y, x)$ where H_0 is the inverse function of I .

⁵¹ The problem of the behaviour of the “actions” for a slow variation of parameters of a multi-frequency integrable system was first considered by Burgers; he calculated that the “actions” are adiabatic invariants [159]. Dirac pointed out the difficulties related to resonances and proved that the “actions” are adiabatic invariants in a two-frequency system under the condition analogous to condition A in § 6.1.6 (without estimates of the change of the “actions”) [211].

⁵² For an open domain of values of h, λ .

⁵³ For an open domain of values of h, y, x .

Adiabatic invariants of linear multi-frequency systems have been studied in detail [377]. This theory relates to linear Hamiltonian systems whose coefficients are periodic in time and in addition depend on a slowly changing parameter $\lambda = \lambda(\varepsilon t)$. It is assumed that for each fixed λ the system is strongly stable, that is, it is stable and any sufficiently small change in the coefficients does not destroy the stability. All the multipliers of a strongly stable system lie on the unit circle and are distinct from ± 1 (see, for example, [10]). Therefore as λ varies the multipliers move within the upper and lower unit semicircles without passing from one semicircle into another.⁵⁴

Definition 6.3. Several multipliers of the unperturbed ($\lambda = \text{const}$) system situated consecutively on the unit circle form a *cluster* if, when λ varies by the law $\lambda = \lambda(\varepsilon t)$, these multipliers collide with one another, but do not collide with the other multipliers (Fig. 6.39).

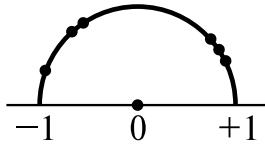

Fig. 6.39.

Theorem 6.31 ([377]). *The linear Hamiltonian system under consideration has at least as many independent adiabatic invariants whose values change by quantities of order ε on times $1/\varepsilon$, as there are clusters formed by the multipliers of the unperturbed system on the upper unit semicircle. These adiabatic invariants are quadratic forms in the phase variables with coefficients depending on time (periodically) and on the parameter λ .*

Corollary 6.2. *If the multipliers are distinct for all λ , then the number of independent adiabatic invariants is equal to the number of degrees of freedom.*

Corollary 6.3. *The linear system under consideration has at least one adiabatic invariant.*

If in the system under consideration the multipliers coincide with one another only at isolated instants of the slow time εt , then the number of independent adiabatic invariants is equal to the number of degrees of freedom. Far from the instants of collision of multipliers, the adiabatic invariants undergo oscillations of order ε . In a neighbourhood of a collision instant, the adiabatic invariants corresponding to the colliding multipliers may change by a quantity $\gg \varepsilon$ (and for a collision of multipliers with non-zero speed, by a quantity of order $\sqrt{\varepsilon}$).

⁵⁴ Since the system is real, the positions of the multipliers are symmetric with respect to the real axis.

6.4.3 Adiabatic Phases

We consider a Hamiltonian system with $n \geq 1$ degrees of freedom depending on an l -dimensional parameter⁵⁵ slowly changing with time, with Hamiltonian $E = E(p, q, \lambda)$, where $\lambda = \lambda(\tau)$ for $\tau = \varepsilon t$. Suppose that for each fixed value of the parameter the system is completely integrable, so that in its phase space there is a domain foliated into invariant tori, and we can introduce action-angle variables $I, \varphi \bmod 2\pi$; the change of variables

$$p = p(I, \varphi, \lambda), \quad q = q(I, \varphi, \lambda) \tag{6.74}$$

is considered to be smooth. The variation of the variables I, φ in a system with a slowly changing parameter is described by equations of the form (6.70) with Hamiltonian $H = H_0(I, \lambda) + \varepsilon H_1(I, \varphi, \tau)$. Suppose that, as τ varies from 0 to 1, the value of the parameter λ describes a closed curve Γ (Fig. 6.40). We consider a solution $I(t), \varphi(t)$ of system (6.70) and calculate $\varphi(1/\varepsilon) - \varphi(0)$. We observe that if an adiabatic approximation is valid for I (that is, $I(t) = I(0) + o(1)$), then the quantity $\varphi(1/\varepsilon) - \varphi(0)$ is invariant in the principal approximation with respect to the choice of the initial value of the phase: a shift of the initial value of the phase by a quantity $a(I, \lambda)$ does not cause in the principal approximation a change in the value $\varphi(1/\varepsilon) - \varphi(0)$ (since $I \approx \text{const}$ and $\lambda(1) = \lambda(0)$).

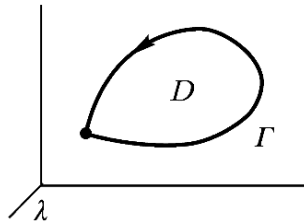

Fig. 6.40.

Proposition 6.5 ([275, 261]). *We have*

$$\begin{aligned} \varphi\left(\frac{1}{\varepsilon}\right) - \varphi(0) &= \chi_{\text{dyn}} + \chi_{\text{geom}} + \chi_{\text{rem}}, \\ \chi_{\text{dyn}} &= \frac{1}{\varepsilon} \int_0^1 \frac{\partial H_0\left(I\left(\frac{\tau}{\varepsilon}\right), \lambda(\tau)\right)}{\partial I} d\tau, \\ \chi_{\text{geom}} &= \int_0^1 \frac{\partial \mathcal{H}_1(I(0), \tau)}{\partial I} d\tau, \quad \mathcal{H}_1 = \langle H_1 \rangle^\varphi. \end{aligned} \tag{6.75}$$

⁵⁵ The values of the parameter belong to some l -dimensional manifold (not necessarily \mathbb{R}^l).

In a single-frequency system ($n = 1$) we have $\chi_{\text{rem}} = O(\varepsilon)$. In a multi-frequency system ($n \geq 2$) under the condition $\det(\partial^2 H_0 / \partial I^2) \neq 0$ we have $|\chi_{\text{rem}}| < \rho$ outside a set of initial data of measure not exceeding $c\sqrt{\varepsilon}/\rho$ for $c = \text{const} > 0$.

◁ From (6.70) we obtain the identity

$$\varphi\left(\frac{1}{\varepsilon}\right) - \varphi(0) = \chi_{\text{dyn}} + \vartheta(t), \quad \vartheta(t) = \varepsilon \int_0^t \frac{\partial H_1(I(\xi), \varphi(\xi), \varepsilon\xi)}{\partial I} d\xi.$$

We add to system (6.70) the equation

$$\dot{\vartheta} = \varepsilon \frac{\partial H_1(I, \varphi, \tau)}{\partial I}.$$

We apply to the resulting system the averaging principle (§6.1.1) and use the assertions on the accuracy of averaging (Theorem 6.1 for single-frequency systems, and Theorem 6.11 for multi-frequency systems). We obtain

$$\vartheta\left(\frac{1}{\varepsilon}\right) = \chi_{\text{geom}} + \chi_{\text{rem}},$$

where χ_{rem} satisfies the estimates indicated above. ▷

In formula (6.75) the quantity χ_{dyn} is called the *dynamic adiabatic phase*: this is the increment of the phase related to the change of the unperturbed frequency. The quantity χ_{geom} is called the *geometric adiabatic phase*, since it is determined by the geometry of the unperturbed system – by the map (6.74) – and does not depend either on the form of the function $H_0(I, \lambda)$ or on the law of variation of the parameter λ describing the curve Γ (the latter follows from the fact that H_1 is proportional to $d\lambda/d\tau$). The geometric adiabatic phase in the general form was introduced by Berry [106, 107] and Hannay [275]. Therefore this phase is also called the Berry phase or the Hannay angle. Earlier this phase was introduced and calculated by Radon in the problem of rotation of the direction of oscillations of an isotropic oscillator when it is slowly transported along a curved surface (see [314]), by Rytov [530] and Vladimirskij [599] in the problem of rotation of the polarization of light in an optical waveguide, by Ishlinskij in the theory of gyroscopes [292, 293], by Pancharatnam [493] also in the problem of rotation of the polarization of light. Berry introduced his phase for problems of quantum mechanics as the phase of the exponent by which the wave function of the system is multiplied if the parameters of the system, changing slowly, return to their initial values and if at the initial instant the wave function was an eigenfunction for the Schrödinger operator.⁵⁶

⁵⁶ If the corresponding eigenvalue is simple for all values of the parameter, then for a slow variation of the parameter the wave function remains an eigenfunction in the principal approximation (the quantum adiabatic theorem [139]). Then the wave functions at the start and at the end of variation of the parameter differ by a factor $e^{-i\psi}$, where ψ is the Berry phase.

The geometric phase introduced above can be obtained as a quasi-classical analogue of this quantum-mechanical phase [107].

Proposition 6.6 (Berry's formula [106]⁵⁷). *We have*

$$\chi_{\text{geom}} = -\frac{\partial}{\partial I} \oint_{\Gamma} \langle p d_{\lambda} q \rangle \quad \text{modd } 2\pi, \tag{6.76}$$

where d_{λ} is the differential with respect to the variables λ , the functions p, q define the change of variables (6.74), and the angular brackets denote the averaging over φ .

◁ The change of variables (6.74) can be defined by using the following (multivalued) generating function $W(I, q, \lambda)$:

$$p = \frac{\partial W}{\partial q}, \quad \varphi = \frac{\partial W}{\partial I}, \quad H_1 = \frac{\partial W}{\partial \lambda} \frac{d\lambda}{d\tau}. \tag{6.77}$$

Since $W = \int p(I, q, \lambda) dq$, two values of W at the same point can differ by the quantity $\oint_{\gamma} p dq$, where γ is a cycle on the torus $I = \text{const}$. This quantity is a linear combination with integer coefficients of the components of the vector $2\pi I$ (see § 5.2.1). Therefore,

$$\frac{\partial}{\partial I} \oint_{\Gamma} d_{\lambda} W = 0 \quad \text{modd } 2\pi. \tag{6.78}$$

From (6.75), (6.77), (6.78) we obtain

$$\begin{aligned} \chi_{\text{geom}} &= \frac{\partial}{\partial I} \oint_{\Gamma} \left\langle \frac{\partial W(I, q, \lambda)}{\partial \lambda} \right\rangle \Big|_{q=q(I, \varphi, \lambda)} d\lambda \\ &= \frac{\partial}{\partial I} \oint_{\Gamma} \left\langle d_{\lambda} W - \frac{\partial W(I, q, \lambda)}{\partial q} \frac{\partial q}{\partial \lambda} d\lambda \right\rangle \\ &= -\frac{\partial}{\partial I} \oint_{\Gamma} \langle p d_{\lambda} q \rangle \quad \text{modd } 2\pi. \end{aligned} \tag{6.79}$$

▷

Corollary 6.4 ([106]). *Suppose that $\lambda \in \mathbb{R}^l$, D is a two-dimensional surface in \mathbb{R}^l spanned over the contour Γ , and the functions p, q in (6.74) are defined for $\lambda \in D$. Then from (6.76) by the Stokes' formula we obtain*

$$\chi_{\text{geom}} = -\frac{\partial}{\partial I} \int_D \langle d_{\lambda} p \wedge d_{\lambda} q \rangle \quad \text{modd } 2\pi. \tag{6.79}$$

⁵⁷ In concrete problems this formula was obtained by Rytov and Vladimirskij [530, 599], Ishlinskij [292, 293], and Pancharatnam [493]. The papers [292, 530, 599] are discussed in [403].

Example 6.32 (Hannay's hoop [275]). A bead slides without friction along a horizontal hoop (Fig. 6.41). The hoop is slowly rotated through the angle 360° in the direction of the bead's motion. Let us find the geometric phase.

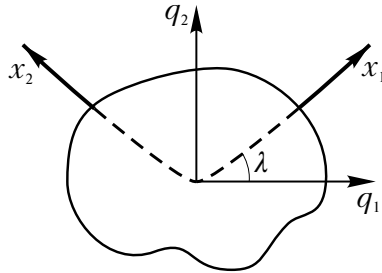

Fig. 6.41.

Let s be the arc length along the hoop measured from some given initial point in the direction of the bead's motion, L the length of the hoop, A the area bounded by the hoop, m the mass of the bead, $p = m\dot{s}$ and $E = \frac{1}{2}m\dot{s}^2$ the momentum and the energy of the bead, respectively. In the unperturbed motion $\dot{s} = \text{const}$; hence for the action–angle variables we have $I = m\dot{s}L/(2\pi)$ and $\varphi = 2\pi s/L \pmod{2\pi}$.

In this problem the Hamiltonian is not of the form that was assumed when formula (6.76) was derived. Therefore first we perform the calculations directly, without using this formula.

We introduce two coordinate systems: a fixed one Oq_1q_2 and the one rigidly attached to the hoop Ox_1x_2 ; the second system is obtained from the first by the rotation through the angle $\lambda = \lambda(\varepsilon t)$, where $\lambda(0) = 0$, $\lambda(1) = 2\pi$ (Fig. 6.41). The hoop is given by the equations $x_1 = f(s)$, $x_2 = g(s)$ in the system Ox_1x_2 , and by the equations

$$\begin{aligned} q_1 &= f(s) \cos \lambda - g(s) \sin \lambda, \\ q_2 &= f(s) \sin \lambda + g(s) \cos \lambda \end{aligned} \tag{6.80}$$

in the system Oq_1q_2 ; here the functions f, g have period L in s . The energy of the bead in its motion on the hoop is given by the formula

$$E = \frac{1}{2}m (\dot{q}_1^2 + \dot{q}_2^2) = \frac{1}{2}m\dot{s}^2 + \varepsilon\lambda' \dot{s}m(fg' - f'g) + O(\varepsilon^2),$$

where prime denotes the derivative of a function with respect to its argument. From this we find the Hamiltonian in the action–angle variables:

$$\begin{aligned} E &= H_0(I) + \varepsilon H_1(I, \varphi, \tau) + O(\varepsilon^2), \\ H_0 &= \frac{1}{2m} \left(\frac{2\pi I}{L} \right)^2, \quad H_1 = -\frac{d\lambda}{d\tau} \frac{2\pi I}{L} (fg' - f'g). \end{aligned} \tag{6.81}$$

Then

$$\begin{aligned}\langle H_1 \rangle &= \frac{1}{2\pi} \int_0^{2\pi} H_1 d\varphi = \frac{1}{L} \int_0^L H_1 ds \\ &= -\frac{d\lambda}{d\tau} \frac{2\pi I}{L^2} \int_0^L (fg' - f'g) ds = -2 \frac{d\lambda}{d\tau} \frac{2\pi IA}{L^2}.\end{aligned}$$

The Hamiltonian has the form (6.70), and formula (6.75) holds with

$$\chi_{\text{geom}} = \int_0^1 \frac{\partial \langle H_1 \rangle}{\partial I} d\tau = - \int_0^{2\pi} 2 \cdot \frac{2\pi}{L^2} A d\lambda = -\frac{8\pi^2 A}{L^2}.$$

Thus, as a result of a slow rotation of the hoop through 360° , the phase of the bead falls behind in the principal approximation by the calculated quantity χ_{geom} from the value that it would have if the hoop were stationary.

One can also obtain this result using formula (6.76) and the following trick [275]. We realize the holonomic constraint – the point slides along the hoop – using a steep potential trough whose bottom coincides with the hoop (cf. § 1.6.2). For fixed λ we obtain a system with fast and slow variables of § 6.4.1; the fast variables describe oscillations across the hoop, and the slow ones the motion along the hoop. In the adiabatic (with respect to the inverse ratio of the speeds of these motions δ) approximation, the system is integrable (see Remark 6.21 to Theorem 6.30), and we can introduce in it action–angle variables K, I . Here K is the “action” of the fast oscillations across the hoop, the value $K = 0$ corresponds to the motion on the hoop in the original system with constraint, and I is the “action” of this motion introduced above. For the resulting problem we can use formula (6.76) to calculate the geometric phase for the slow rotation of the trough through 360° ; the value of this phase for $K = 0$ must coincide with the geometric phase of the original problem (of course, this assertion needs to be justified; in fact the question is about the possibility of commuting the passages to the limits as $\varepsilon \rightarrow 0$ and $\delta \rightarrow 0$). We shall carry out the calculations without justification.

In the problem of motion in a potential trough there are the coordinates q_1, q_2 and their conjugate momenta p_1, p_2 . In the motion at the bottom of the trough (that is, on the hoop) for $\lambda = \text{const}$ the variation of the coordinates q_1, q_2 is given by formulae (6.80), and for the momenta we have $p_i = m\dot{q}_i$ or

$$p_1 = m(f' \cos \lambda - g' \sin \lambda) \dot{s}, \quad p_2 = m(f' \sin \lambda + g' \cos \lambda) \dot{s}. \quad (6.82)$$

The transition formulae from the action–angle variables to the variables p_i, q_i at the bottom of the trough ($K = 0$) are obtained from these formulae by expressing s, \dot{s} in terms of the action–angle variables I, φ of the unperturbed

motion on the hoop introduced above. Then

$$\oint_{\Gamma} \langle p \, d\lambda q \rangle = \frac{1}{L} \int_0^L m \dot{s} (f g' - f' g) \, ds = \frac{2m \dot{s} A}{L} = \frac{4\pi I A}{L^2},$$

$$\chi_{\text{geom}} = -\frac{\partial}{\partial I} \int_0^{2\pi} \frac{4\pi I A}{L^2} \, d\lambda = -\frac{8\pi^2 A}{L^2},$$

as claimed. \triangle

The formulae of adiabatic approximation define the so-called *adiabatic connection* on the fibre bundle whose base space is the space of parameters, and the fibres are copies of the phase space of the Hamiltonian system under consideration [261, 430]. To define a connection means to define, for each curve \mathcal{L} in the base space, a rule of identifying the fibres corresponding to the initial and terminal points of this curve. For the adiabatic connection this rule is as follows:

$$I' = I, \quad \varphi' = \varphi + \int_{\mathcal{L}} \frac{\partial \mathcal{H}_1(I, \lambda(\tau))}{\partial I} \, d\tau.$$

Here (I, φ) and (I', φ') are the action–angle variables in the two copies of the phase space. If $\mathcal{L} = \Gamma$ now is a closed curve in the base space passing through a point λ_0 , then we obtain a map of the copy of the phase space corresponding to λ_0 onto itself. The set of such maps forms a group called the *holonomy group* of the connection at the point λ_0 (if the base space is connected, then this group is independent of λ_0). The elements of the holonomy group of the adiabatic connection are the maps

$$I' = I, \quad \varphi' = \varphi + \chi_{\text{geom}}(I, \Gamma)$$

(the last summand is the geometric phase, which corresponds to going around the contour Γ for a given value of the “action” I).

In Riemannian geometry (and therefore also in general relativity theory) a fundamental role is played by the Levi-Civita connection (the definition of which is rather difficult), which defines parallel transport of vectors along a manifold with a Riemannian metric. Radon noted in 1918 that the most physically natural definition of this (quite non-obvious) transport is provided by the theory of adiabatic invariants.

Namely, let us place at a point of the manifold some oscillatory system, for example, let us suspend a Foucault pendulum over this point, or consider in the tangent space at this point a Hooke elastic system with potential energy proportional to the square of the distance from the original point.

Under appropriate initial conditions the system will perform an eigenoscillation in the direction defined by some (any) vector of the tangent space.

We now slowly and smoothly transport our oscillatory system along some path on our manifold. It follows from adiabatic theory that the oscillation will remain (in the adiabatic approximation) an eigen-oscillation. Its direction (polarization) will rotate somehow during the motion of the point along the path. It is this rotation (which proves to be an orthogonal transformation of the initial tangent space into the terminal one) which is the Levi-Civita parallel transport (or connection).

It is interesting that Radon's theory was not understood by geometers (because they were not familiar with adiabatic invariants) and therefore was unfairly forgotten.

An interesting example of application of an adiabatic invariant is provided by the theory of connections on the fibre bundle of eigenvectors of Hermitian operators depending on parameters. (This problem arises naturally in the construction of the topological theory of the integer quantum Hall effect.)

Consider the linear ordinary differential equation $\dot{z} = A(\lambda)z$, $z \in \mathbb{C}^n$, with a slowly and smoothly varying parameter $\lambda(\varepsilon t)$ and with a skew-Hermitian operator A . Let an eigenvector $\xi(\lambda_0)$ of the operator at the initial instant $t = 0$ be chosen as the initial condition. Then over time $t \sim 1/\varepsilon$ the oscillations remain (in the adiabatic approximation) almost eigen-oscillations, with an eigenvalue of the instantaneous matrix $A(\varepsilon t)$. But this does not yet define an eigenvector even if it is normalized: the phase remains undefined.

The adiabatic approximation makes the phases co-ordinated at all times. The corresponding "adiabatic connection" is orthogonal to the circle of eigenvectors, that is, for an adiabatic change of the matrix (and therefore of the circle of eigenvectors) we choose the nearest (in the Hermitian metric of the space \mathbb{C}^n) vector on the new circle of normalized eigenvectors [81].

One of the manifestations of the considered adiabatic connection in quantum mechanics is the Aharonov–Bohm effect [60]: the vector potential of a magnetic field affects the quantum-mechanical phase of a particle moving in a domain where the field itself is absent.

6.4.4 Procedure for Eliminating Fast Variables. Conservation Time of Adiabatic Invariants

For single-frequency Hamiltonian systems with fast and slow variables one can eliminate the fast variables symplectically and therefore obtain quantities that are conserved with a greater accuracy. In the variables I , φ , Y , X introduced in § 6.4.1⁵⁸, the Hamiltonian of the problem has the form

$$H = H_0(I, Y, X) + \varepsilon H_1(I, \varphi, Y, X, \varepsilon). \quad (6.83)$$

Theorem 6.32. *From a smooth, of class C^∞ , single-frequency Hamiltonian of the form (6.83) the fast phase ψ can be eliminated by a formal symplectic change of variables $(I, \varphi, Y, X) \mapsto (J, \psi, \eta, \xi)$.*

⁵⁸ We omit the bar over the variables.

◁ The new Hamiltonian $\mathcal{H} = \mathcal{H}(J, \eta, \xi, \varepsilon)$ and the generating function $J\varphi + \varepsilon S(J, \varphi, \eta, X, \varepsilon)$ of the change of variables are connected by the relation

$$H\left(J + \varepsilon \frac{\partial S}{\partial \varphi}, \varphi, \eta + \varepsilon^2 \frac{\partial S}{\partial X}, X, \varepsilon\right) = \mathcal{H}\left(J, \eta, X + \varepsilon^2 \frac{\partial S}{\partial \eta}, \varepsilon\right). \quad (6.84)$$

We seek \mathcal{H} and S in the form of formal series in ε :

$$\mathcal{H} = H_0 + \varepsilon \mathcal{H}_1 + \varepsilon^2 \mathcal{H}_2 + \dots, \quad S = S_1 + \varepsilon S_2 + \dots. \quad (6.85)$$

Substituting these series into (6.84) and equating the terms of the same order in ε we obtain the system of equations

$$\begin{aligned} \frac{\partial H_0}{\partial J} \frac{\partial S_1}{\partial \varphi} + H_1(J, \varphi, \eta, X, 0) &= \mathcal{H}_1(J, \eta, X), \\ \frac{\partial H_0}{\partial J} \frac{\partial S_i}{\partial \varphi} + G_i(J, \varphi, \eta, X) &= \mathcal{H}_i(J, \eta, X), \quad i \geq 2. \end{aligned}$$

The function G_i is determined by the terms $S_1, \mathcal{H}_1, \dots, S_{i-1}, \mathcal{H}_{i-1}$ in the expansions (6.85). In the notation $\langle \cdot \rangle^\varphi$ and $\{ \cdot \}^\varphi$ for the averaging operator and the integration operator introduced in § 6.1.2, the solution of this system is given by the formulae

$$\begin{aligned} \mathcal{H}_1 &= \langle H_1 \rangle^\varphi, & S_1 &= -\{H_1\}^\varphi + S_1^0, \\ \mathcal{H}_i &= \langle G_i \rangle^\varphi, & S_i &= -\{G_i\}^\varphi + S_i^0, \quad i \geq 2, \end{aligned}$$

where the S_i^0 are arbitrary functions of J, η, X . One often chooses $S_i^0 \equiv 0$. ▷

Corollary 6.5. *The “function” J is a formal integral of the problem.*

Corollary 6.6. *If the series for the change of variables is truncated at the terms of order ε^m , then such a shortened change of variables leaves the dependence of the Hamiltonian on the phase only in terms of order ε^{m+1} . The function J defined by this change of variables undergoes only oscillations of order ε^{m+1} over time $1/\varepsilon$.*

The series (6.85) may be divergent even in an analytic system (see an example in [455]). The following assertion describes the limiting accuracy that can be achieved in the phase elimination.

Proposition 6.7 ([455], cf. Theorem 6.2). *The Hamiltonian (6.83) of a single-frequency analytic system with fast and slow variables can be transformed by a symplectic change of variables that differs from the identity by $O(\varepsilon)$ into a sum of two terms the first of which is independent of the phase and the second is exponentially small ($O(\exp(-c_1^{-1}/\varepsilon))$ for $c_1 = \text{const} > 0$).*

Corollary 6.7. *In a single-frequency analytic system the action variable I undergoes only oscillations of order ε over time $T = \exp(\frac{1}{2} c_1^{-1}/\varepsilon)$. Thus, the adiabatic invariance is conserved on an exponentially long time interval.⁵⁹*

◁ The change of variables of Proposition 6.7 transforms I into the quantity $J = I + O(\varepsilon)$, which changes exponentially slowly and, consequently, its change over time T is exponentially small. ▷

Remark 6.23. For a one-degree of freedom Hamiltonian system depending on a slowly changing parameter, the elimination of the fast phase can be carried out by the scheme described above, with natural simplifications. The Hamiltonian of the problem has the form $H = H_0(I, \tau) + \varepsilon H_1(I, \varphi, \tau)$, $\tau = \varepsilon t$ (cf. (6.70)). The generating function of a change of variables is sought for in the form $J\varphi + \varepsilon S(J, \varphi, \tau, \varepsilon)$. The variation of the new variables is described by the Hamiltonian system with the Hamiltonian $\mathcal{H} = H + \varepsilon \partial S / \partial \tau$.

Remark 6.24. Procedures for eliminating the fast phases can also be used for systems with impacts, of the type described in Examples 6.30, 6.31; see [264].

6.4.5 Accuracy of Conservation of Adiabatic Invariants

Suppose that in a system with one degree of freedom depending on a parameter λ this parameter varies slowly so that it tends sufficiently fast to definite limits as $\varepsilon t \rightarrow \pm\infty$. Then there exist limit values of the adiabatic invariant $I(+\infty)$ and $I(-\infty)$, and we can consider the increment of the adiabatic invariant over infinitely long time

$$\Delta I = I(+\infty) - I(-\infty).$$

Although for finite t the quantity I undergoes oscillations of order ε , the increment ΔI proves to be much smaller than ε .

If the parameter varies smoothly ($\lambda \in C^\infty$), then $\Delta I = O(\varepsilon^\infty)$, that is, ΔI decreases faster than any power of ε as $\varepsilon \rightarrow 0$; see [375]. Indeed, the procedure of § 6.4.4 allows one to introduce, for any m , a quantity J which undergoes only oscillations $O(\varepsilon^m)$ along the motion and coincides with I in the limit as $t \rightarrow \pm\infty$.

If the dependence of λ on εt is analytic, then $\Delta I = O(\exp(-c^{-1}/\varepsilon))$ for $c = \text{const} > 0$; see [453, 558]. Indeed, according to Proposition 6.7 one can introduce a quantity J which undergoes only exponentially small oscillation along the motion and coincides with I in the limit as $t \rightarrow \pm\infty$.

For the linear oscillator

$$\ddot{x} = -\omega^2(\varepsilon t)x, \quad \omega(\pm\infty) = \omega_\pm,$$

⁵⁹ Here it is assumed that during this time the system does not leave a given domain of size of order 1.

with an analytic frequency $\omega(\varepsilon t) > \text{const} > 0$, the asymptotics of ΔI is known [219, 234]. The calculation of it is based on the analytic continuation of the solution to a domain of complex values of time t . Suppose that the function $\omega^2(\tau)$ can be analytically continued to some complex closed neighbourhood of the real axis, has in this neighbourhood a simple zero at $\tau = \tau_*$ with $\text{Im } \tau_* > 0$, and has no other zeros with $\text{Im } \tau > 0$. Suppose that each level line $\{\tau: \text{Im} \int_0^\tau \omega(\xi) d\xi = B\}$ for $0 \leq B < \text{Im} \int_0^{\tau_*} \omega(\xi) d\xi$ has a connected component contained in this neighbourhood. Then the change of the “action” along the solution with a real initial condition $I(0) = I_0, \varphi(0) = \varphi_0$ is given by the formula

$$\Delta I = \text{Im} \left[-2I_0(1 + O(\varepsilon)) \exp \left(2i \left(\varphi_0 + \frac{1}{\varepsilon} \int_0^{\tau_*} \omega(\xi) d\xi \right) \right) \right].$$

The problem of calculating the change of the adiabatic invariant of the linear oscillator is equivalent to the quantum-mechanical problem of calculating, in the quasi-classical approximation, the coefficient of over-barrier reflection, which was solved by different methods in [502, 503]; see also [368], § 52.

In [558] a method of analytic continuation for solutions of nonlinear perturbed systems was found and used to calculate the exponent in the formula for ΔI , and for a number of cases, also the factor in front of the exponent. The exponent in the generic case proved to be equal to $-M$, where M is the minimum of the imaginary parts of the increments of the phase in the adiabatic approximation

$$\dot{\varphi} = \omega_0(I_-, \varepsilon t), \quad \omega_0 = \frac{\partial H_0}{\partial I}, \quad I_- = I(-\infty)$$

along the paths on the plane of complex time t from the real axis to the singular points of the Hamiltonian and to the zeros of the unperturbed frequency in the upper half-plane (Fig. 6.42).

More precisely, on the plane of the complex slow time τ we consider the level lines (Fig. 6.42)

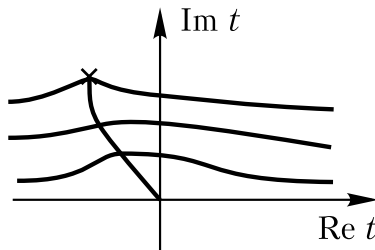

Fig. 6.42.

$$L_{I,B} = \left\{ \tau: \operatorname{Im} \int_0^\tau \omega_0(I, \xi) d\xi = B \right\}.$$

In particular, for $B = 0$ the line $L_{I_-, B}$ is the real axis, and for small B , a line close to the real axis. The family of the $L_{I_-, B}$ can be smoothly continued by increasing B , until at some $B = B_*$ the level line will have to pass through a point where $\omega_0(I_-, \tau)$ vanishes or has a singularity. Suppose that for any $B_0 \in (0, B_*)$ the Hamiltonian of the system is analytic and bounded by a given constant for all I sufficiently close to I_- , $|I - I_-| < c_1^{-1}$, for all τ in the domain D_I filled with the curves $L_{I,B}$, $|B| < B_0$, and for $|\operatorname{Im} \varphi| < c_2^{-1}$. (Here the constants c_1, c_2 depend on B_0 .) Then $\Delta I = O(e^{-B/\varepsilon})$ for any $B \in (0, B_*)$. (The same estimate follows from the result of [589], cf. § 6.1.4.)

◁ The approach of [558] is as follows.

Suppose that the Hamiltonian is reduced to the form (6.70). One step of the perturbation procedure of § 6.4.4 allows one to perform a change of variables $I, \varphi \mapsto J, \psi$ that is $O(\varepsilon)$ -close to the identity map and is such that in the new variables the Hamiltonian takes the form

$$\mathcal{H} = H_0(J, \tau) + \varepsilon \mathcal{H}_1(J, \tau) + \varepsilon^2 H_2(J, \psi, \tau, \varepsilon), \quad \mathcal{H}_1 = \langle H_1 \rangle^\varphi. \quad (6.86)$$

The change of variables $(I, \varphi) \mapsto (J, \psi)$ tends to the identity map as $\tau \mapsto \pm\infty$. Suppose that for $t = t_0 = \tau_0/\varepsilon$ we are given initial data J_0, ψ_0 (so far all these quantities are real). Then we can find the solution $J(t), \psi(t)$ with these initial data and introduce the data at infinity:

$$\begin{aligned} I_\pm &= I(\pm\infty) = \lim_{t \rightarrow \pm\infty} J(t), \\ \varphi_\pm &= \lim_{t \rightarrow \pm\infty} \left(\psi(t) - \frac{1}{\varepsilon} \int_0^{\varepsilon t} \omega_{01}(I_\pm, \xi, \varepsilon) d\xi \right), \end{aligned} \quad (6.87)$$

where $\omega_{01} = \omega_0 + \varepsilon \partial \mathcal{H}_1 / \partial J$. We also introduce $\Delta\varphi = \varphi_+ - \varphi_-$. We have $I_\pm = J_0 + O(\varepsilon^2)$ and $\varphi_\pm = \psi_0 - \frac{1}{\varepsilon} \int_0^{\tau_0} \omega_{01}(I_\pm, \xi, \varepsilon) d\xi + O(\varepsilon)$. We can express I_+ and φ_+ in terms of I_- and φ_- (this connection is independent of the choice of τ_0). We obtain the scattering problem $(I_-, \varphi_-) \mapsto (I_+, \varphi_+)$:

$$\begin{aligned} I_+ &= I_+(I_-, \varphi_-, \varepsilon), & \varphi_+ &= \varphi_+(I_-, \varphi_-, \varepsilon), \\ \Delta I &= \Delta I(I_-, \varphi_-, \varepsilon), & \Delta\varphi &= \Delta\varphi(I_-, \varphi_-, \varepsilon). \end{aligned} \quad (6.88)$$

Here,

$$\Delta I = O(\varepsilon^2), \quad \Delta\varphi = O(\varepsilon). \quad (6.89)$$

The function H_2 in (6.86) can be analytically continued with respect to ψ to a strip of width of order 1 around the real axis: $|\operatorname{Im} \psi| < c_2^{-1}/2$. Hence, at first glance, the functions $\Delta I, \Delta\varphi$ too must be continuable with respect to φ_- ,

generally speaking, only to a strip of width of order 1 around the real axis. However, it turns out that $\Delta I, \Delta\varphi$ can be analytically continued to the much wider strip $|\operatorname{Im} \varphi_-| \leq B/\varepsilon$ for any $B \in (0, B_*)$ and satisfy estimates (6.89) in this strip, as it will be explained below after Example 6.33. From this, for the Fourier coefficients of the expansion $\Delta I = \sum_k (\Delta I)_k e^{ik\varphi_-}$ we obtain

$$\begin{aligned} (\Delta I)_k &= \frac{1}{2\pi} \int_0^{2\pi} \Delta I(\varphi_-) e^{-ik\varphi_-} d\varphi_- \\ &= \frac{1}{2\pi} \int_0^{2\pi} \Delta I\left(-is\frac{B}{\varepsilon} + \varphi\right) e^{-|k|B/\varepsilon - ik\varphi} d\varphi \\ &= O(e^{-|k|B/\varepsilon}), \end{aligned} \tag{6.90}$$

where $s = \operatorname{sign} k$, and similarly for $(\Delta\varphi)_k$.

Furthermore, the transformation $I_-, \varphi_- \mapsto I_+, \varphi_+$ is symplectic and can be given by a generating function:

$$I_- = I_+ + \varepsilon \frac{\partial W(\varphi_-, I_+, \varepsilon)}{\partial \varphi_-}, \quad \varphi_+ = \varphi_- + \varepsilon \frac{\partial W(\varphi_-, I_+, \varepsilon)}{\partial I_+}.$$

Thus, $I_- = I_+ + \varepsilon u(I_+, \varphi_-, \varepsilon)$ and $\langle u(I_+, \varphi_-, \varepsilon) \rangle^{\varphi_-} = 0$. Hence,

$$I_+ = I_- - \varepsilon u(I_-, \varphi_-, \varepsilon) + \frac{1}{2} \varepsilon^2 \frac{\partial u^2(I_-, \varphi_-, \varepsilon)}{\partial I_-} + \dots$$

From this relation, averaging over φ_- we obtain the well-known relation (see, for example, [621], Ch. 6, § 1)

$$\langle \Delta I \rangle^{\varphi_-} = \frac{1}{2} \frac{\partial}{\partial I_-} \langle (\Delta I)^2 \rangle^{\varphi_-} + \dots$$

From (6.90) we find that the remainder denoted in the last formula by the dots is $O(e^{-3B/\varepsilon})$. Hence,

$$(\Delta I)_0 = \frac{\partial}{\partial I_-} |(\Delta I)_1|^2 + O(e^{-3B/\varepsilon}) = O(e^{-2B/\varepsilon}).$$

Then

$$\Delta I = 2 \operatorname{Re} ((\Delta I)_1 e^{i\varphi_-}) + O(e^{-2B/\varepsilon}) = O(e^{-B/\varepsilon}). \quad \triangleright$$

In the simplest examples the properties of the functions $\Delta I, \Delta\varphi$ described above can be verified by a straightforward calculation.

Example 6.33. Consider the system with Hamiltonian $H = \omega I + \varepsilon H_1(\varphi, \tau)$, where

$$H_1 = \left(\sum_k a_k e^{ik\varphi} \right) \cdot \frac{1}{1 + \tau^2}, \quad a_k = 2^{-|k|}, \quad \tau = \varepsilon t, \quad \omega = \operatorname{const} > 0.$$

Here $\varphi_+ = \varphi_- = \psi(0)$, $\psi(t) = \varphi_- + \omega t$, and

$$\begin{aligned} \Delta I &= -\varepsilon \int_{-\infty}^{\infty} \frac{\partial H_1(\varphi_- + \omega t, \varepsilon t)}{\partial \varphi} dt \\ &= -\varepsilon \int_{-\infty}^{\infty} \sum_{k \neq 0} a_k i k \frac{e^{ik(\varphi_- + \omega t)}}{1 + (\varepsilon t)^2} dt \\ &= -\sum_{k \neq 0} \pi i k a_k e^{-|k|\omega/\varepsilon} e^{ik\varphi_-} \end{aligned}$$

(the integrals are calculated by using residues).

The original Hamiltonian is analytic in the strip $|\operatorname{Im} \varphi| < \ln 2$. The function ΔI is analytic in the strip $|\operatorname{Im} \varphi_-| < \ln 2 + \omega/\varepsilon$. △

◁ We now show how an analytic continuation of the functions (6.88) is constructed. Above we were given data at $t = \tau_0/\varepsilon$, from which we constructed the solution $J(t)$, $\psi(t)$, and the data I_{\pm} , φ_{\pm} at $\pm\infty$ by relations (6.87). One can, on the contrary, fix the data I_- , φ_- at $-\infty$, or I_+ , φ_+ at $+\infty$ (all these quantities are so far real) and use them to find the solution $J(t)$, $\psi(t)$ such that (6.87) holds. For that we must solve the system of integral equations (respectively, with sign “-” or “+”)

$$\begin{aligned} J(t) &= I_{\pm} - \varepsilon^2 \int_{\pm\infty}^t \frac{\partial H_2(J(\vartheta), \psi(\vartheta), \varepsilon\vartheta, \varepsilon)}{\partial \psi} d\vartheta, \\ \psi(t) &= \varphi_{\pm} + \int_0^t \omega_{01}(I_{\pm}, \varepsilon\vartheta, \varepsilon) d\vartheta \\ &\quad + \int_{\pm\infty}^t \left(\omega_{01}(J(\vartheta), \varepsilon\vartheta, \varepsilon) - \omega_{01}(I_{\pm}, \varepsilon\vartheta, \varepsilon) \right. \\ &\quad \left. + \varepsilon^2 \frac{\partial H_2(J(\vartheta), \psi(\vartheta), \varepsilon\vartheta, \varepsilon)}{\partial J} \right) d\vartheta. \end{aligned} \tag{6.91}$$

The existence and uniqueness of a solution of this system can be established in the standard way, for example, by using the contracting map principle (if $\lambda(\tau)$ tends to a constant sufficiently fast as $\tau \rightarrow \pm\infty$).

Suppose that the solutions $(J^{\pm}(t), \psi^{\pm}(t))$ of systems (6.91) $_{\pm}$ are found. These solutions must coincide. Hence the equalities $J^+(t_0) = J^-(t_0)$ and $\psi^+(t_0) = \psi^-(t_0)$ determine a connection between the data at $+\infty$ and at $-\infty$ in the form (6.88). We set $R_- = (-\infty, C)$ and $R_+ = (-C, +\infty)$, where $C > 0$ is any prescribed constant. For $\varepsilon t \in R_{\pm}$ the last term in (6.91) $_{\pm}$ is $O(\varepsilon)$, so

that

$$\psi(t) = \varphi_{\pm} + \int_0^t \omega_{01}(I_{\pm}, \varepsilon \vartheta, \varepsilon) d\vartheta + O(\varepsilon). \tag{6.92}$$

Now suppose that the quantity φ_- is complex, $|\operatorname{Im} \varphi_-| \leq B_0/\varepsilon < B_*/\varepsilon$; the quantity I_- is real as before. We take some $I_+ = I_- + O(\varepsilon^2)$ and $\varphi_+ = \varphi_- + O(\varepsilon)$. In the standard way one can establish the existence, the uniqueness, and the analyticity in t, I_{\pm} , and φ_{\pm} of a solution $J^{\pm}(t), \psi^{\pm}(t)$ of system (6.91) $_{\pm}$ when the complex slow time $\tau = \varepsilon t$ belongs to the domain V^{\pm} – the intersection of a sufficiently narrow $c_3^{-1}\varepsilon$ -neighbourhood of the curve

$$\mathcal{L}^{\pm} = \left\{ \tau: \operatorname{Im} \frac{1}{\varepsilon} \int_0^{\tau} \omega_{01}(I_{\pm}, \xi, \varepsilon) d\xi = -\operatorname{Im} \varphi_{\pm} \right\}$$

and the half-plane $\operatorname{Re} \tau \in R_{\pm}$. The integrals in (6.91) $_{\pm}$ are taken along a curve contained in V^{\pm} . It is important that, in view of the estimate (6.92), the solution cannot reach the boundary of the analyticity domain of the system: $|\operatorname{Im} \psi| < \frac{1}{4}c_2^{-1}$. The domains V^+ and V^- must intersect, since for $\operatorname{Re} \tau \in R_- \cap R_+$ the curve \mathcal{L}^+ is contained in a $O(\varepsilon^2)$ -neighbourhood of the curve \mathcal{L}^- . Taking any $\tau_0 \in V^- \cap V^+$ and $t_0 = \tau_0/\varepsilon$, from the equalities $J^+(t_0) = J^-(t_0)$ and $\psi^+(t_0) = \psi^-(t_0)$ we find the analytic dependence (6.88), and the estimates (6.89) hold, as required. \triangleright

Studying the singularities of an analytic continuation of the function ΔI enables one to calculate also the factor in front of the exponent in the asymptotics of ΔI .

Example 6.34. Consider a mathematical pendulum in a gravitational field slowly changing with time. The equation of motion has the form

$$\ddot{q} + \Omega^2(\tau) \sin q = 0, \quad \dot{\tau} = \varepsilon.$$

Suppose that the function $\Omega(\tau)$ is analytic and tends to definite limits sufficiently fast as $\tau \rightarrow \pm\infty$. For a fixed τ , on the phase portrait of the pendulum on the plane q, \dot{q} there are the domains of rotations and oscillations of the pendulum separated by the separatrices. The area of the oscillatory domain is $S(\tau) = 16\Omega(\tau)$. Suppose that $0 < m \leq S(\tau) \leq M$ for real τ . In the adiabatic approximation we have $I = I_- = \text{const}$ along the motion.

Suppose that a motion starts in the rotation (oscillatory) domain, and $2\pi I_- > M/2$ (respectively, $2\pi I_- < m$). Then during the entire motion the phase point does not reach the separatrix and remains in the rotation domain or, respectively, in the oscillatory domain.

In the analysis of a motion starting in the rotation (oscillatory) domain we denote by τ_* the complex instant of the slow time at which $\frac{1}{2}S(\tau_*) = 2\pi I_-$ (respectively, $S(\tau_*) = 2\pi I_-$), $\operatorname{Im} \tau_* > 0$. This is the complex instant of

reaching the separatrix in the adiabatic approximation. Suppose that τ_* is the singularity of the Hamiltonian in the action–angle variables that is nearest to the real axis (the distance to the real axis is measured by the imaginary part of the increment of the phase in the adiabatic approximation over the time of motion from 0 to τ_*). The approach of [558] gives the following value for the change of the adiabatic invariant over the time interval $(-\infty, \infty)$:

$$\Delta I = \operatorname{Re} \left[\left(-\frac{8\Omega'(\tau_*)}{\pi\Omega(\tau_*)} \nu + o(1) \right) \exp \left(i\nu \left(\varphi_- + \frac{1}{\varepsilon} \int_0^{\tau_*} \omega_0(I_-, \xi) d\xi \right) \right) \right].$$

Here $\nu = 1$ for motion in the rotation domain, $\nu = 2$ for motion in the oscillatory domain, $\omega_0(I, \tau)$ is the frequency of the unperturbed motion, the initial value of the phase φ is chosen on the straight line $q = 0$, and prime denotes differentiation with respect to τ . It is assumed that $\Omega(\tau_*) \neq 0$ and $\Omega'(\tau_*) \neq 0$. For the oscillatory domain the main contribution to the asymptotics of ΔI is given by the harmonic $e^{2i\varphi_-}$ (rather than $e^{i\varphi_-}$ as usual) due to the symmetry of the problem.

The change of the adiabatic invariant in the case where the phase point reaches the separatrix at a real instant is considered in §6.4.7. \triangle

6.4.6 Perpetual Conservation of Adiabatic Invariants

Over infinite time adiabatic invariants can undergo considerable evolution due to accumulation of small perturbations.

Example 6.35. Consider the linear oscillator (Mathieu’s equation)

$$\ddot{x} = -\omega^2(1 + \alpha \cos \varepsilon t)x, \quad \alpha = \text{const} < 1.$$

The equilibrium $x = 0$ can be unstable for arbitrarily small ε (the phenomenon of parametric resonance [10]). The adiabatic invariant changes unboundedly. \triangle

However, it turns out that for a periodic variation of the parameter, such non-conservation of the adiabatic invariant is related to the linearity of the system (more precisely, to the fact that the frequency of oscillations is independent of the amplitude). In a nonlinear system, as the amplitude increases, the frequency changes, and the oscillations do not have enough time to accrue before the resonance condition is violated.

Definition 6.4. An adiabatic invariant is said to be *perpetual* if for sufficiently small ε its value deviates little from the initial value for $-\infty < t < \infty$.

Theorem 6.33 ([7]). *For a slow periodic variation of the Hamiltonian function of a nonlinear oscillatory system with one degree of freedom the action variable I is a perpetual adiabatic invariant. Most of the phase space of the problem is filled with the invariant tori close to the tori $I = \text{const}$.*

◁ First of all we state the requisite condition of nonlinearity of the system. In the action-angle variables the Hamiltonian of the problem has the form

$$H = H_0(I, \tau) + \varepsilon H_1(I, \varphi, \tau), \quad \tau = \varepsilon t, \quad (6.93)$$

and is 2π -periodic in φ and τ . We denote by $\bar{\omega}(I)$ the mean value over τ of the “adiabatic” frequency of the variation of the phase $\omega(I, \tau) = \partial H_0 / \partial I$. In the statement of the theorem the system is considered to be nonlinear if this mean frequency depends on I :

$$\frac{\partial \bar{\omega}}{\partial I} \neq 0. \quad (6.94)$$

The proof of the theorem is based on the results of KAM theory (§ 6.3). In order to reduce the equations of motion to the standard form of KAM theory (the “fundamental problem of dynamics”) we have to perform certain transformations.

As a new time we introduce the phase φ , and as new variables, the value h of the old Hamiltonian (6.93) and the old slow time τ . The variation of these variables is described by the Hamiltonian system with the Hamiltonian

$$\varepsilon I(h, \tau, \varphi, \varepsilon) = \varepsilon I_0(h, \tau) + \varepsilon^2 I_1(h, \tau, \varphi, \varepsilon) \quad (6.95)$$

(see § 5.1.1). Here the function I is determined from the equation $H = h$, where H is given by formula (6.93) (see § 5.1.1). The function I_0 is determined from the equation $H = h$ for $\varepsilon = 0$; thus, I_0 is the “action” of the unperturbed system expressed in terms of the value of the unperturbed Hamiltonian and τ . The function I has period 2π in φ and τ . The phase portrait of the system with Hamiltonian $I_0(h, \tau)$ is shown in Fig. 6.43. Let \bar{h} , $\bar{\tau}$ be the action-angle variables of this system. In these variables we have

$$\varepsilon I = \varepsilon \bar{I}_0(\bar{h}) + \varepsilon^2 \bar{I}_1(\bar{h}, \bar{\tau}, \varphi, \varepsilon),$$

where \bar{I}_0 is the inverse function of $\langle H_0(I, \tau) \rangle^\tau$.

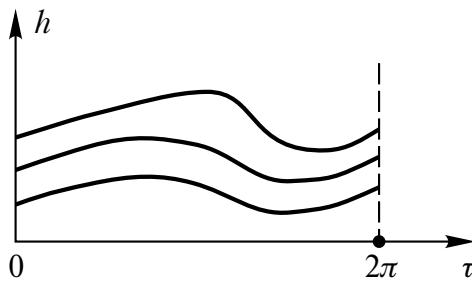

Fig. 6.43.

We have obtained a system with one and a half degrees of freedom and *proper degeneracy* considered in § 6.3.3.B. By condition (6.94) the degeneracy is removable. According to the results of § 6.3.3.B this system has many invariant tori close to the tori $\bar{h} = \text{const}$; the value \bar{h} perpetually undergoes oscillations with amplitude $O(\varepsilon)$. Therefore in the phase space I, φ, τ of the original system there are many invariant tori close to the tori $I = \text{const}$; the value of I perpetually undergoes oscillations with amplitude $O(\varepsilon)$. \triangleright

Remark 6.25. If the parameters of the system depend on time conditionally periodically, and the set of frequencies $\varepsilon\Xi$ satisfies the usual incommensurability conditions $|(k, \Xi)| > c^{-1}|k|^{-\nu}$, $k \in \mathbb{Z}^m \setminus \{0\}$, then I is also a perpetual adiabatic invariant [7].

A perpetual adiabatic invariant also exists (under certain conditions) in a conservative system with two degrees of freedom whose Hamiltonian depends slowly on one of the coordinates [7]. According to Theorem 6.30 the motion in such a problem is approximately described by the Hamiltonian $H_0(I, y, x)$. Suppose that the phase curves of this Hamiltonian for fixed I are closed (as in Fig. 6.30). Then in the approximation under consideration the motion in the phase space takes place on the two-dimensional tori defined by the conditions $I = \text{const}$, $H_0 = \text{const}$. This motion has two frequencies, and one of the frequencies is $1/\varepsilon$ times lower than the other. If for a given $H_0 = \text{const}$ the frequency ratio changes as I varies, then the results of KAM theory imply the existence in the exact system of many invariant tori close to the invariant tori of the approximate system. As always in the case of two degrees of freedom, this implies stability: the action variable I is perpetually close to its initial value. See the details in [7]. From this conclusion it follows, in particular, that the axially symmetric magnetic trap of Example 6.28 holds charged particles forever.

6.4.7 Adiabatic Invariants in Systems with Separatrix Crossings

A. Separatrix Crossings in Adiabatic Approximation

We again consider a Hamiltonian system with one degree of freedom depending on parameters slowly changing with time; the Hamiltonian is $E = E(p, q, \tau)$, where $\dot{\tau} = \varepsilon$. Suppose that for each fixed value of τ the phase portrait of the Hamiltonian E has the form shown in Fig. 6.15. Through the saddle singular point C there pass the separatrices l_1 and l_2 , which divide the portrait into the domains G_1, G_2, G_3 . As the parameter τ varies with time, the portrait in Fig. 6.15 is deformed, the curves on the portrait – level lines of the Hamiltonian – are of course no longer phase trajectories of the system. As a result of variation of the parameter the phase point $p(t), q(t)$ can cross the separatrix in Fig. 6.15. A separatrix crossing is approximately described by the procedure of the averaging method of § 6.1.10. In the case considered here this procedure can be simplified, since the action variable of the unperturbed

system is an integral of the averaged system, and the integrals Θ_ν along the separatrices introduced in § 6.1.10 satisfy the formulae⁶⁰

$$\Theta_\nu(\tau) = - \oint_{l_\nu} \frac{\partial E}{\partial \tau} dt \equiv \frac{dS_\nu}{d\tau}, \quad \nu = 1, 2, \quad (6.96)$$

where $S_\nu = S_\nu(\tau)$, $\nu = 1, 2$, is the area of the domain G_ν in Fig. 6.15.

We set $S_3(\tau) = S_1(\tau) + S_2(\tau)$ and $\Theta_3(\tau) = \Theta_1(\tau) + \Theta_2(\tau)$. We assume for definiteness that $\Theta_\nu > 0$, $\nu = 1, 2, 3$. Then the phase points from the domain G_3 will pass into G_1 or G_2 . Suppose that for $\tau = 0$ the phase point is in the domain G_3 , and at this point the action variable has value $I_0 > S_3(0)/(2\pi)$. Let τ_* be the instant of crossing the separatrix calculated in the adiabatic approximation: $S_3(\tau_*) = 2\pi I_0$. Then the procedure of § 6.1.10 leads to the following scheme of description of motion in the adiabatic approximation:

- 1°. For $0 \leq \tau \leq \tau_*$ the motion occurs in the domain G_3 and along the trajectory $I = I_0$.
- 2°. At $\tau = \tau_*$ the phase point is captured into the domain G_ν , $\nu = 1, 2$, with probability $P_\nu(\tau_*)$, where

$$P_\nu(\tau) = \frac{\Theta_\nu(\tau)}{\Theta_1(\tau) + \Theta_2(\tau)}. \quad (6.97)$$

- 3°. For $\tau_* \leq \tau \leq 1$ the phase point captured into the domain G_ν , $\nu = 1, 2$, moves so that $2\pi I = S_\nu(\tau_*)$.

Such a scheme of description of motion was first used in [386, 387] in the problem of motion of charged quasi-particles.

The estimates of the accuracy of description of motion according to this scheme and the definition of probability of capture are as in § 6.1.10; see [450]. Several examples of using this scheme are contained in [277].

What happens if the Hamiltonian depends periodically on τ ? Suppose that at $\tau = 0$ the motion starts in the domain G_3 , the value of I_0 and the graphs of the functions S_ν on the segment $[0, 2\pi]$ (the period) are as in Fig. 6.44. In the adiabatic approximation we obtain that at $\tau = 2\pi$ the motion again occurs in G_3 , and the action variable has one of the two possible values $I^{(\nu)}$, $\nu = 1, 2$ (Fig. 6.44), where the probability of the value $I^{(\nu)}$ is given by formula (6.97) with $\tau = \tau_*$. For the original system this means the following. Consider the phase points which at $\tau = 0$ fill the annulus $\Pi = \{I, \varphi: |I - I_0| < \delta\}$, $\varepsilon \ll \delta \ll 1$. Then at $\tau = 2\pi$ for most of these phase points the value of the

⁶⁰ The last equality in (6.96) is a consequence of the well-known formula [367]: $2\pi \partial I(h, \tau) / \partial \tau = - \oint_{E=h} (\partial E / \partial \tau) dt$, where $I(h, \tau)$ is the value of the action variable on the trajectory with $E = h$; one must assume that $E = 0$ on the separatrices. This formula, in turn, follows from the fact that the action variable is an integral of the averaged system.

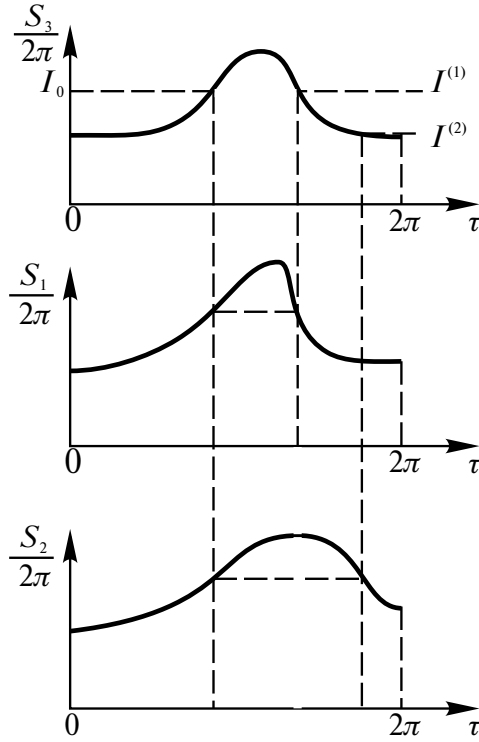

Fig. 6.44.

action variable is close either to $I^{(1)}$ or to $I^{(2)}$. The ratio of the measure of the initial conditions leading to a value $I \approx I^{(\nu)}$ to the area of the whole annulus Π is given in the principal approximation by formula (6.97). At $\tau = 4\pi$ for most of the phase points the value of the action variable is close to one of the four values predicted by the adiabatic approximation, at $\tau = 8\pi$ to one of the eight values, and so on.⁶¹ This mechanism results in the destruction of the adiabatic invariance of the action variable under multiple separatrix crossings over time of order $1/\varepsilon$. Another, slower mechanism of destruction is discussed in § 6.4.7.B below. If no separatrix crossings occur in the adiabatic approximation⁶², then the action variable is a perpetual adiabatic invariant (see § 6.4.6).

⁶¹ The theory expounded above does not allow one to calculate the probabilities of these values. Apparently, in the generic case for multiple separatrix crossings, captures in different domains can be regarded as independent random events. Then the probabilities of different values of the action variable are calculated as the products of the probabilities (6.97).

⁶² That is, if at the initial instant the point is in G_3 , then $2\pi I_0 > \max S_3(\tau) + c^{-1}$, and if the point is in G_ν , $\nu = 1, 2$, then $2\pi I_0 < \min_\tau S_\nu(\tau) - c^{-1}$, $c = \text{const} > 0$.

In similar fashion one can consider in the adiabatic approximation separatrix crossings in slow-fast Hamiltonian systems in which one degree of freedom corresponds to the fast variables, and the other degrees of freedom to the slow variables. The Hamiltonian of such a system has the form $E = E(p, q, y, x)$, where $(p, q) \in \mathbb{R}^2$ and $(y, \varepsilon^{-1}x) \in \mathbb{R}^{2m}$ are pairs of conjugate canonical variables (see § 6.4.1). For fixed values of the slow variables y, x , for the fast variables p, q we obtain a Hamiltonian system with one degree of freedom (a fast system). Suppose that its phase portrait is as in Fig. 6.15 (for all y, x). The system of the adiabatic approximation (see § 6.4.1) is first constructed separately for each of the domains G_ν in Fig. 6.15 and has the form

$$\dot{y} = -\varepsilon \frac{\partial H_0}{\partial x}, \quad \dot{x} = \varepsilon \frac{\partial H_0}{\partial y}, \quad H_0 = H_0(I, y, x), \quad I = \text{const}, \quad (6.98)$$

where I is the action variable of the fast system, and H_0 is the Hamiltonian E expressed in terms of I, y, x . For the integrals Θ_ν along the separatrices introduced in § 6.1.10 we obtain the formulae

$$\Theta_\nu(y, x) = - \oint_{l_\nu} \{E, h_C\} dt \equiv \{S_\nu, h_C\}, \quad \nu = 1, 2.$$

Here $S_\nu = S_\nu(y, x)$ is the area of the domain G_ν in Fig. 6.15, $h_C = h_C(y, x)$ is the value of the Hamiltonian E at the saddle point C , and $\{, \}$ is the Poisson bracket in the variables y, x . We set $S_3 = S_1 + S_2$ and $\Theta_3 = \Theta_1 + \Theta_2$. For the domain G_ν the condition of reaching the separatrix has the form $2\pi I = S_\nu(y, x)$. We assume for definiteness that $\Theta_\nu > 0$, $\nu = 1, 2, 3$. Then the phase points from the domain G_3 will pass into G_1 or G_2 . Suppose that a phase point starts the motion in the domain G_3 , and that $I = I_0$ at the initial instant. Then in the adiabatic approximation the motion up to reaching the separatrix is described by the solution of system (6.98) for the domain G_3 with $I = I_0$. Suppose that this solution reaches the separatrix at $\varepsilon t = \tau_*$ having $y = y_*$, $x = x_*$. Then the phase point can continue the motion in the domain G_ν , $\nu = 1, 2$, with probability $P_\nu(y_*, x_*)$, where

$$P_\nu(y, x) = \frac{\Theta_\nu(y, x)}{\Theta_1(y, x) + \Theta_2(y, x)}. \quad (6.99)$$

The motion of the phase points that get into the domain G_ν is described in the adiabatic approximation by the solution of system (6.98) for the domain G_ν with $I = S_\nu(y_*, x_*)/(2\pi)$ and with the initial condition $y = y_*$, $x = x_*$ at $\varepsilon t = \tau_*$.

If in the adiabatic approximation the dynamics of the slow variables results in multiple separatrix crossings, then in general the number of values of the action variable possible in the adiabatic approximation will increase with each crossing, and the adiabatic invariance will undergo destruction (similarly to what was described above for the case of a slow periodic dependence of the Hamiltonian on time).

B. Deviations from Adiabatic Approximation

Here we discuss the asymptotic formulae obtained in [162, 456, 457, 583] for the deviations of the true motion from the predictions of the adiabatic approximation of §6.4.7.A. These formulae show that during a crossing of a narrow neighbourhood of a separatrix there arises a small quasi-random jump of the adiabatic invariant, which is not taken into account by the adiabatic approximation.

We return to the Hamiltonian system with one degree of freedom and slowly varying parameters considered in §6.4.7.A; the phase portrait of the system with frozen parameters is shown in Fig. 6.15. Suppose that at $\tau = 0$ the phase point is in the domain G_3 , and at $\tau = 1$ in the domain G_ν , where $\nu = 1$ or $\nu = 2$. Suppose that the adiabatic approximation predicts that a separatrix crossing occurs at $\tau = \tau_*$. In §6.4.4 we described the construction of the change of variables $I, \varphi \mapsto J, \psi$, which introduces, instead of the action variable I , the quantity J , which far from the separatrices changes along the trajectory only by $O(\varepsilon^2)$ on times of order $1/\varepsilon$. This quantity is called the *improved adiabatic invariant*. For our phase point, let $J = J_0$ at $\tau = 0$, and $J = J_1$ at $\tau = 1$. We apply the scheme of adiabatic approximation of §6.4.7.A using J instead of I . We obtain that in this approximation the value of J at $\tau = 1$ is $J'_1 = S_\nu(\tau'_*)/(2\pi)$, where τ'_* is determined from the relation $S_3(\tau'_*) = 2\pi J_0$. The quantity $\Delta J = J_1 - J'_1$ characterizes the deviation from the adiabatic approximation. In the asymptotics of this quantity the terms $\gg \varepsilon^2$, if they exist, are determined by the motion in a narrow neighbourhood of the separatrices (since far from the separatrices the change of J is $O(\varepsilon^2)$). The leading terms – of order $\varepsilon \ln \varepsilon$ and ε – in this asymptotics were calculated in [583] for the pendulum in a slowly varying gravitational field, and in [162, 456] for the general case of a Hamiltonian system with one degree of freedom and slowly varying parameters. The term of order $\varepsilon \ln \varepsilon$ has quite a simple form:

$$(\varepsilon \ln \varepsilon) \frac{\Theta_\nu^* a_*}{2\pi} \left(1 - \frac{2\Theta_\nu^*}{\Theta_3^*} \right) \left(\xi - \frac{1}{2} \right) \tag{6.100}$$

Here $\Theta_j^* = \Theta_j(\tau_*)$, $j = 1, 2, 3$, $a_* = a(\tau_*)$, $a(\tau) = 1/\sqrt{-D(\tau)}$, D is the determinant of the matrix of second derivatives of the Hamiltonian at the saddle singular point C (see Fig. 6.15), $\xi = -h_*/(\varepsilon\Theta_\nu^*)$, h_* is the value of the Hamiltonian at the first instant when the phase point reaches the bisector of the angle between the separatrices in the domain G_ν near the saddle point. The expression for the terms of order ε is more complicated (see [162, 456]); we give this expression for the special case of motion in a symmetric potential well with two minima. In this case, $\Delta J = J_1 - J_0/2$. Because of the symmetry we have $\Theta_1^* = \Theta_2^* = \Theta_3^*/2 = \Theta_*$, the term $\sim \varepsilon \ln \varepsilon$ vanishes, and

$$\Delta J = -\frac{1}{2\pi} \varepsilon a_* \Theta_* \ln (2 \sin (\pi \xi)) + O(\varepsilon^{3/2} (|\ln \varepsilon| + (1 - \xi)^{-1})) \tag{6.101}$$

for $c\sqrt{\varepsilon} \leq \xi \leq 1 - c\sqrt{\varepsilon}$, where $c = \text{const} > 0$.

Example 6.36 ([583]). Consider a pendulum in a gravitational field slowly varying with time: the Hamiltonian is $E = p^2/2 - \omega^2(\tau)(\cos q + 1)$. If the gravitational force decreases, then an oscillating pendulum after some time starts rotating. The phase portrait of the pendulum (Fig. 6.20) is divided by the separatrices into the domains of oscillations G_3 , and rotations $G_{1,2}$. From the viewpoint of studying separatrix crossing, the problem is equivalent to the problem of motion in a symmetric potential well with two minima. The quantity ΔJ is given by formula (6.101) with $a = 1/\omega$ and $\Theta = 8d\omega/d\tau$. \triangle

For the case where a separatrix crossing occurs near an instant of bifurcation of the phase portrait of the system with frozen parameter – in Fig. 6.15 the saddle merges with the centre and the separatrix vanishes – the quantity ΔJ was calculated in [209, 210].

There are asymptotic formulae expressing the quantity ξ in (6.100), (6.101) in terms of the initial data J_0, φ_0 [163]. In particular, in the case of a symmetric potential well with two minima, if the position of the hump separating the wells does not change with time and the angle φ is measured from this position, then

$$\xi = -\frac{1}{\pi} \left(\varphi_0 + \frac{1}{\varepsilon} \int_0^{\tau_*} \omega_0(J_0, \tau) d\tau \right) + o(1) \pmod{1}$$

for $c\sqrt{\varepsilon} < \xi < 1 - c\sqrt{\varepsilon}$, where $\omega_0 = \partial H_0/\partial I$ is the frequency of the motion in the unperturbed ($\tau = \text{const}$) system. The quantity ξ is very sensitive to a change in the initial data: a change of I_0 by a quantity $\sim \varepsilon$ results in a change of ξ by a quantity ~ 1 . Hence it is appropriate to interpret ξ as a random quantity, similarly to how getting into one or another domain after crossing a separatrix is regarded as a random event. For a given initial point $M_0 = (I_0, \varphi_0)$ the probability of the event $\{\xi \in (a, b)\}$ is given by definition by the formula (cf. § 6.1.10)

$$P\{\xi \in (a, b)\} = \lim_{\delta \rightarrow 0} \lim_{\varepsilon \rightarrow 0} \frac{\text{meas } U_{a,b}^{\delta, \varepsilon}}{\text{meas } U^\delta},$$

where U^δ is the δ -neighbourhood of the point M_0 , $U_{a,b}^{\delta, \varepsilon}$ is the subset of this neighbourhood composed of the initial conditions for which $\xi \in (a, b)$, and meas is the standard area on \mathbb{R}^2 . The probability thus defined can be calculated.

Proposition 6.8. *The quantity $P\{\xi \in (a, b)\}$ is equal to the length of the interval $(a, b) \cap (0, 1)$.*

Thus, the quantity ξ is uniformly distributed on the interval $(0, 1)$. Asymptotic formulae expressing ΔJ in terms of ξ now allow us to regard ΔJ as a random quantity with a known (in the principal approximation) distribution. For example, from (6.101) we obtain that for a symmetric potential well

with two minima the quantity $\Delta J/\varepsilon$ has, in the limit as $\varepsilon \rightarrow 0$, mean 0 and variance $a_*^2 \theta_*^2/48$.

The deviations from the adiabatic approximation considered here play an important role in the case where the Hamiltonian depends periodically on τ when multiple separatrix crossings occur. Numerical experiments show that small quasi-random deviations from the adiabatic approximation accumulate and cause the destruction of the adiabatic invariance of the action variable for a set of initial conditions of measure ~ 1 .

Example 6.37. Consider the pendulum in a gravitational field slowly and periodically changing with time. Here destruction of the adiabatic invariance is not found in the adiabatic approximation (in contrast to the general case of § 6.4.7.A): in this approximation, at a passage from oscillations into rotation the value of the action variable is divided in half, and at the reverse passage it is doubled. The Poincaré section of the problem is depicted in Fig. 6.45: the positions of several (eight) phase points at times equal to multiples of the period of variation of gravitation are shown (the computations were carried out by Sidorenko). The dotted curves in Fig. 6.45 show the boundary of the domain of separatrix crossings calculated in the adiabatic approximation. Smooth curves outside the domain of separatrix crossings are invariant curves of the Poincaré return map. The chaotically scattered points in the domain

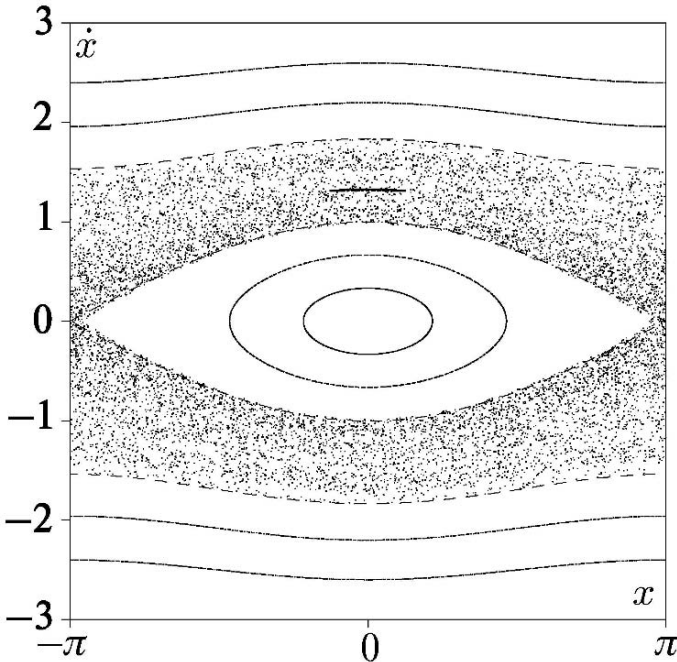

Fig. 6.45.

of separatrix crossings is the trajectory of one phase point under iterations of the Poincaré map. It is clear from the picture, but so far it is not proved, that there is a large, of area ~ 1 , domain of destruction of the adiabatic invariance. However, it turns out that in this problem, as in all problems with symmetry of the domains G_1 and G_2 , there are also islands of perpetual adiabatic invariance, which also have total area of order 1; see [466]. These islands surround the stable fixed points of the Poincaré map corresponding to the stable periodic motions in which the pendulum passes from oscillations into rotation and back. There are $\sim 1/\varepsilon$ such periodic motions; the stability island for each of them has area $\sim \varepsilon$. Consequently, the total area of the islands is estimated from below by a quantity independent of ε . For reasons that are not yet understood, this quantity itself is small (in the numerical examples, $\sim 0.01 - 0.02$); therefore the islands can be hardly seen in the picture. (For a long time it was considered that there are no such islands; in [229] it was shown that the area of an individual stability island, if it exists, cannot exceed a quantity $\sim \varepsilon$.) The variation of the value of I for motions in a stability island is $O(\varepsilon)$. In the domain of separatrix crossings in Fig. 6.45 one can see an object looking like a segment of a smooth curve. When the vertical scale is enlarged, this segment turns into a smooth closed curve that is (approximately) the boundary of a stability island surrounding a fixed point of the Poincaré map.

In problems without symmetry, where the asymptotics of ΔJ contains the term $\sim \varepsilon \ln \varepsilon$ (6.100), in the “thick” of the domain of separatrix crossings there are no stable periodic motions of period $\sim 1/\varepsilon$ and, correspondingly, there are no such stability islands [466].

Suppose that the quasi-random deviations from the adiabatic approximation in a sequence of separatrix crossings can be regarded as independent or weakly dependent random quantities (clearly, this assumption can be true only outside stability islands). Then the cumulative deviation from the adiabatic approximation over N crossings is a random quantity with variance $\sim N\varepsilon^2$ (as long as the motion takes place in the domain where the deviation from the adiabatic approximation over one separatrix crossing has variance $\sim \varepsilon^2$). Thus, over $N \sim 1/\varepsilon^2$ separatrix crossings, that is, over time $\sim 1/\varepsilon^3$ the adiabatic invariance is destroyed – a typical deviation from the adiabatic approximation becomes a quantity ~ 1 . Numerical experiments confirm this estimate of the time of destruction of the adiabatic invariance (see, for example, [149]). \triangle

Similar phenomena happen, of course, also in slow-fast Hamiltonian systems; there are corresponding asymptotic formulae for the deviations from the adiabatic approximation [457, 470]. Destruction of the adiabatic invariance in multiple separatrix crossings in such systems explains the emerging of chaos in the dynamics of charged particles in the tail of the Earth’s magnetosphere [156] and plays a key role in Wisdom’s theory of the origin of the Kirkwood gap at the resonance $3 : 1$ in the asteroid belt [458, 604].

Non-Integrable Systems

A common feature of various approaches to the problem of integrating Hamiltonian systems considered in Chapter 5 is the existence of sufficiently many independent first integrals – “conservation laws”. Unfortunately, in a typical situation not only do we fail to find integrals, but they do not exist at all, since the trajectories of Hamiltonian systems, generally speaking, do not lie on low-dimensional invariant manifolds. Here, of course, the question is about the existence of integrals in the entire phase space: there always exists a complete set of independent integrals in a small neighbourhood of a non-singular point.

The first rigorous results on non-integrability of Hamiltonian systems are due to Poincaré. The essence of Poincaré’s idea is that complicated behaviour of solutions (for example, birth of non-degenerate periodic solutions, splitting of asymptotic surfaces, and so on) is incompatible with complete integrability of Hamilton’s equations. In this chapter we discuss the main methods for proving the non-integrability of Hamiltonian systems based on finding various non-trivial dynamical effects that are uncharacteristic of completely integrable systems. A more detailed exposition is contained in [28, 30].

7.1 Nearly Integrable Hamiltonian Systems

Here we describe a method for proving the non-existence of additional analytic integrals, which is largely due to Poincaré and which is based on studying bifurcations of long-periodic solutions.

Suppose that the direct product $M = D \times \mathbb{T}^n \{\varphi \bmod 2\pi\}$ (where D is a domain in $\mathbb{R}^n = \{I\}$) is equipped with the standard symplectic structure $dI \wedge d\varphi$, and $H: M \times (-\varepsilon_0, \varepsilon_0) \rightarrow \mathbb{R}$ is an analytic function such that $H(I, \varphi, 0) = H_0(I)$. For $\varepsilon = 0$ we have a completely integrable Hamiltonian system with Hamiltonian H_0 . We consider the full system

$$\dot{I} = -\frac{\partial H}{\partial \varphi}, \quad \dot{\varphi} = \frac{\partial H}{\partial I}; \quad H = H_0(I) + \varepsilon H_1(I, \varphi) + \dots \quad (7.1)$$

for small values of the parameter ε . Numerous examples were given in Chapter 6. In this section we study the problem of the existence of the first integrals of equations (7.1) that are independent of the function H and analytic (or, more generally, formally analytic¹) in the parameter ε . Recall that the existence of a complete commutative set of such integrals is related to possibility of construction, and to convergence, of different variants of perturbation theory for Hamiltonian systems (see § 6.2.2).

7.1.1 The Poincaré Method

First we give some definitions. Let

$$H_1 = \sum_{m \in \mathbb{Z}^n} h_m(I) \exp i\langle m, \varphi \rangle.$$

The *Poincaré set* is the set of values of $I \in D$ for which there exist $n - 1$ linearly independent vectors $k_1, \dots, k_{n-1} \in \mathbb{Z}^n$ such that

- 1) $\langle k_s, \omega(I) \rangle = 0$, $1 \leq s \leq n - 1$, where $\omega = H'_0$, and
- 2) $h_{k_s}(I) \neq 0$.

Let $\mathcal{A}(V)$ be the class of functions analytic in a domain $V \subset \mathbb{R}^u$. We call a set $A \subset V$ a *key set* (or a *uniqueness set*) for the class $\mathcal{A}(V)$ if any analytic function vanishing on A vanishes identically everywhere in V . Thus, if two analytic functions coincide on A , then they coincide on the whole V . For example, a set of points of an interval $\Delta \subset \mathbb{R}$ is a key set for the class $\mathcal{A}(\Delta)$ if and only if it has a limit point inside Δ . The sufficiency of this condition is obvious, and the necessity follows from the Weierstrass product theorem. Note that if A is a uniqueness set for the class of functions $C^\infty(V)$, then A is dense in V .

Functions f_1, \dots, f_m ($m \leq n$) in the class $\mathcal{A}(V)$ are said to be *dependent* (*independent*) at a point $x_0 \in V$ if their differentials are linearly dependent (respectively, independent) at this point. An equivalent definition of dependence: the rank of the Jacobi matrix

$$\frac{\partial(f_1, \dots, f_m)}{\partial(x_1, \dots, x_n)}$$

at the point x_0 is less than m (where x_1, \dots, x_n are coordinates in \mathbb{R}^n). If the functions f_1, \dots, f_m are dependent at every point $x \in V$, then they are said to be *dependent* (in the domain V). Conversely, if they are independent at least at one point, then they are independent at almost every point of a connected domain V . We call such functions *independent*. If the functions are dependent at every point of a key set $A \subset V$, then they are dependent.

¹ A formal series in ε is called formally analytic if its coefficients are analytic functions of the phase variables.

In exactly the same way the properties of dependence and independence are defined for analytic functions on a connected analytic manifold M . It is worth mentioning that if some functions in the class $\mathcal{A}(M)$ are dependent in some open domain $V \subset M$, then they are dependent at every point of M .

Theorem 7.1. *Suppose that the unperturbed system is non-degenerate:*

$$\det\left(\frac{\partial^2 H_0}{\partial I^2}\right) \neq 0$$

in the domain D . Let $I^0 \in D$ be a non-critical point of the function H_0 , and suppose that in any neighbourhood U of I^0 the Poincaré set is a key set for the class $\mathcal{A}(U)$. Then Hamilton's equations (7.1) do not have a formal integral F independent of the function H that can be represented as a formal power series $\sum_{s \geq 0} F_s(I, \varphi)\varepsilon^s$ with coefficients analytic in the domain $D \times \mathbb{T}^n$ (cf. [41, 27]).

We consider a formal series $\sum f_s \varepsilon^s$ to be equal to zero if $f_s = 0$ for all s . A formal series F is a formal integral of the canonical equations with Hamiltonian H if the formal series $\{H, F\}$ is equal to zero. Two formal series are considered to be dependent if all the minors of the second order of their Jacobi matrix vanish identically as formal series in powers of ε .

For the proof of Theorem 7.1 we shall need the following lemma.

Lemma 7.1. *Suppose that functions $F_s: D \times \mathbb{T}^n \rightarrow \mathbb{R}$ are continuously differentiable, and the series $\sum F_s(I, \varphi)\varepsilon^s$ is a formal integral of equations (7.1) with non-degenerate function H_0 . Then*

- 1) $F_0(I, \varphi)$ is independent of φ , and
- 2) the functions H_0 and F_0 are dependent at the points of the Poincaré set.

◁ The condition $\{H, F\} = 0$ is equivalent to the sequence of equations

$$\{H_0, F_0\} = 0, \quad \{H_0, F_1\} + \{H_1, F_0\} = 0, \quad \dots \quad (7.2)$$

It follows from the first equation that F_0 is an integral of the unperturbed equations with Hamiltonian function H_0 . Let $I = I^*$ be a non-resonant torus. Then $F_0(I^*, \varphi)$ is independent of φ , since any trajectory fills a non-resonant torus everywhere densely. To complete the proof of conclusion 1) it remains to take into account that the function F_0 is continuous and the set of non-resonant tori of a non-degenerate integrable system is everywhere dense.

From the second equation (7.2) we obtain the following sequence of equalities for the Fourier coefficients h_m and f_m of the functions H_1 and $F_1 = \sum f_m(I) \exp i\langle m, \varphi \rangle$:

$$\left\langle m, \frac{\partial H_0}{\partial I} \right\rangle f_m(I) = \left\langle m, \frac{\partial F_0}{\partial I} \right\rangle h_m(I), \quad m \in \mathbb{Z}^n.$$

The condition for solubility of these equations with respect to f_m at a point of the Poincaré set is the dependence of the vectors $\partial H_0 / \partial I$ and $\partial F_0 / \partial I$. ▷

◁ *Proof of Theorem 7.1.* Since at the point $I^0 \in D$ there is a non-zero derivative among $\partial H_0/\partial I_1, \dots, \partial H_0/\partial I_n$, in a small neighbourhood U of this point we can take H_0, I_2, \dots, I_n for local coordinates (if $H'_{0I_1} \neq 0$).

According to Lemma 7.1 the functions H_0 and F_0 are dependent on the Poincaré set. Since the minors of the Jacobi matrix

$$\frac{\partial(H_0, F_0)}{\partial(I_1, \dots, I_n)}$$

are analytic in U and the Poincaré set is a key set, the functions H_0 and F_0 are dependent in the entire domain U . Consequently, in a neighbourhood of the value $H_0(I^0)$ we have the equality $F_0 = F_0(H_0)$ in the new coordinates.

We set $F - F_0(H) = \varepsilon\Phi$. Then Φ is a formal integral of the canonical equations (7.1). Let

$$\Phi = \sum_{s \geq 0} \Phi_s \varepsilon^s.$$

Then by Lemma 7.1 the function Φ_0 is independent of the angle variables φ , while Φ_0 and H_0 are dependent in the domain U . Consequently, $\Phi_0 = \Phi_0(H_0)$, and again $\Phi_0 - \Phi_0(H) = \varepsilon\Psi$. But then $F = F_0(H) + \varepsilon\Phi_0(H) + \varepsilon^2\Psi$. Repeating this operation the required number of times we obtain that the expansion of every minor of the second order of the Jacobi matrix

$$\frac{\partial(H, F)}{\partial(I, \varphi)}$$

in a series in powers of ε starts with terms of arbitrarily high order. Hence the functions H and F are dependent. \triangleright

Theorem 7.2. *Suppose that the function H_0 is non-degenerate in the domain D , and the Poincaré set is everywhere dense in D . Then equations (7.1) do not have a formal integral $\sum F_s \varepsilon^s$ that is independent of H and has infinitely differentiable coefficients $F_s: D \times \mathbb{T}^n \rightarrow \mathbb{R}$.*

This assertion can be easily proved by the same method as Theorem 7.1.

Remark 7.1. For $n = 2$ Kolmogorov's theorem on the conservation of conditionally periodic motions implies the existence of a first integral that is analytic in ε and has continuous coefficients that are not everywhere constant. On the contrary, in the multidimensional case, apparently, even a continuous integral is impossible for a system of the general form (see [8]).

7.1.2 Birth of Isolated Periodic Solutions as an Obstruction to Integrability

We recall some facts in the theory of periodic solutions of differential equations. The eigenvalues λ of the monodromy operator of a T -periodic solution are called the *multipliers*, and the numbers α defined by the equality

$\lambda = \exp(\alpha T)$, the *characteristic exponents*. The multipliers λ can be complex numbers; hence the characteristic numbers α are not uniquely determined. In the autonomous case one of the multipliers λ is always equal to 1 (a corresponding eigenvector is tangent to the trajectory of the periodic solution).

Proposition 7.1 (Poincaré–Lyapunov). *In the case of a Hamiltonian system with n degrees of freedom the characteristic polynomial $p(\lambda)$ of the monodromy operator is reciprocal: $p(\lambda^{-1}) = \lambda^{-2n}p(\lambda)$.*

For the proof, see, for example, [10].

Theorem 7.3 (Poincaré [41]). *Suppose that a Hamiltonian system with Hamiltonian H has p integrals $F_1 = H, F_2, \dots, F_p$ whose differentials are linearly independent at each point of the trajectory of a periodic solution. Then $p + 1$ characteristic exponents of this solution are equal to zero. If the integrals F_s commute, then at least $2p$ of the exponents are equal to zero.*

Corollary 7.1. *A periodic solution of an autonomous Hamiltonian system always has two zero characteristic exponents.*

One exponent is zero because the Hamiltonian system is autonomous, and another is zero due to the existence of the integral H (which has no critical points on the trajectories of periodic solutions). If the other characteristic exponents are non-zero, then the periodic solution is said to be *non-degenerate*. Non-degenerate solutions are isolated in the sense that on the corresponding $(2n - 1)$ -dimensional level of the energy integral H , in a small neighbourhood of the periodic trajectory there are no other periodic solutions with period close to T . In the case of two degrees of freedom, a non-degenerate solution with real exponents is usually called *hyperbolic*, and with purely imaginary exponents, *elliptic*. A hyperbolic periodic solution is unstable, while an elliptic is orbitally stable in the first approximation.

Corollary 7.2. *If a Hamiltonian system has a complete set of integrals in involution whose differentials are linearly independent at each point of the trajectory of a periodic solution, then the spectrum of the monodromy operator of this solution consists of the single point $\lambda = 1$.*

Poincaré's theorem gives us a method for proving non-integrability: if the trajectories of non-degenerate periodic solutions fill the phase space everywhere densely, or at least form a key set, then the Hamiltonian system has no additional analytic integrals. Apparently, in generic Hamiltonian systems the periodic trajectories are indeed everywhere dense (Poincaré [41], §36). This fact has not yet been proved. In connection with Poincaré's conjecture we point out the following result relating to the geodesic flows on Riemannian manifolds of negative curvature: all the periodic solutions are of hyperbolic type and the set of their trajectories fills the phase space everywhere densely [4].

For nearly integrable Hamiltonian systems one can prove the existence of a large number of non-degenerate periodic solutions and derive the results of § 7.1.1 from this fact. For simplicity we confine ourselves to the case of two degrees of freedom.

Suppose that for $I = I^0$ the frequencies ω_1 and ω_2 of the unperturbed integrable problem are commensurable, and $\omega_1 \neq 0$. Then the perturbing function $H_1(I^0, \omega_1 t, \omega_2 t + \lambda)$ is periodic in t with some period T . We consider its mean value

$$\bar{H}_1(I^0, \lambda) = \lim_{s \rightarrow \infty} \frac{1}{s} \int_0^s H_1(I^0, \omega_1 t, \omega_2 t + \lambda) dt = \frac{1}{T} \int_0^T H_1 dt. \tag{7.3}$$

Theorem 7.4 (Poincaré). *Suppose that the following conditions hold:*

- 1) $\det \left(\frac{\partial^2 H_0}{\partial I^2} \right) \neq 0$ at the point $I = I^0$,
- 2) for some $\lambda = \lambda^*$ the derivative vanishes, $\frac{\partial \bar{H}_1}{\partial \lambda} = 0$, but $\frac{\partial^2 \bar{H}_1}{\partial \lambda^2} \neq 0$.

Then for small $\varepsilon \neq 0$ there exists a periodic solution of the perturbed Hamiltonian system (7.1) whose period is equal to T ; this solution depends analytically on the parameter ε and for $\varepsilon = 0$ coincides with the periodic solution

$$I = I^0, \quad \varphi_1 = \omega_1 t, \quad \varphi_2 = \omega_2 t + \lambda^*$$

of the unperturbed system. The two characteristic exponents $\pm \alpha$ of this solution can be expanded in a convergent series in powers of $\sqrt{\varepsilon}$:

$$\alpha = \alpha_1 \sqrt{\varepsilon} + \alpha_2 \varepsilon + \alpha_3 \varepsilon \sqrt{\varepsilon} + \dots ,$$

and

$$\omega_1^2 \alpha_1^2 = \frac{\partial^2 \bar{H}_1}{\partial \lambda^2}(\lambda^*) \left(\omega_1^2 \frac{\partial^2 H_0}{\partial I_2^2} - 2\omega_1 \omega_2 \frac{\partial^2 H_0}{\partial I_1 \partial I_2} + \omega_2^2 \frac{\partial^2 H_0}{\partial I_1^2} \right). \tag{7.4}$$

The proof can be found in the books [41, 27].

The function $\bar{H}_1(I^0, \lambda)$ is periodic in λ with period 2π . Therefore there exist at least two values of λ for which $\partial \bar{H}_1 / \partial \lambda = 0$. In the general case these critical points are non-degenerate. There are exactly as many local minima (where $\partial^2 \bar{H}_1 / \partial \lambda^2 > 0$) as local maxima (where $\partial^2 \bar{H}_1 / \partial \lambda^2 < 0$). In a typical situation, at $I = I^0$ the following quadratic form is non-zero:

$$\omega_1^2 \frac{\partial^2 H_0}{\partial I_2^2} - 2\omega_1 \omega_2 \frac{\partial^2 H_0}{\partial I_1 \partial I_2} + \omega_2^2 \frac{\partial^2 H_0}{\partial I_1^2} \neq 0. \tag{7.5}$$

By the way, this condition means geometrically that the curve $H_0(I) = h$ has no inflection point at $I = I_0$. Thus, the equation $d\bar{H}_1 = 0$ has as many roots for which $\alpha_1^2 > 0$, as for which $\alpha_1^2 < 0$. This is equivalent to that for small values of $\varepsilon \neq 0$ the perturbed system has exactly as many periodic solutions of elliptic type, as of hyperbolic type. In this situation they usually say that

pairs of isolated periodic solutions are born when the unperturbed invariant torus $I = I^0$ disintegrates. According to the results of KAM theory the trajectories of typical elliptic periodic solutions are “surrounded” by invariant tori. A hyperbolic periodic solution has two invariant surfaces (*separatrices*) filled with solutions asymptotically approaching the periodic trajectory as $t \rightarrow \pm\infty$. Different *asymptotic surfaces* can intersect forming a rather tangled network (see Fig. 6.28). The behaviour of asymptotic surfaces will be discussed in detail in the next section.

An essential basis for proving non-integrability of perturbed equations is Lemma 7.1: if $F = F_0(I, \varphi) + \varepsilon F_1(I, \varphi) + \dots$ is a first integral of the canonical equations (7.1), then F_0 is independent of φ , and the functions H_0 and F_0 are dependent at the points of the Poincaré set. The first part of the lemma follows from the non-degeneracy of the unperturbed problem. Using Theorem 7.3 we now prove that the functions H_0 and F_0 are dependent on the set of unperturbed tori $I = I^0$ satisfying inequality (7.5) and the conditions of Theorem 7.4.

◁ Indeed, the periodic solutions $\Gamma(\varepsilon)$ that are born from the family of periodic solutions on the resonant torus I^0 satisfying the conditions of Theorem 7.4 are non-degenerate. Therefore (Theorem 7.4) the functions H and F are dependent at every point of the trajectory $\Gamma(\varepsilon)$. We let ε tend to zero. The periodic solution $\Gamma(\varepsilon)$ will become one of the periodic solutions $\Gamma(0)$ of the unperturbed problem lying on the torus $I = I^0$, while the functions H and F will become equal to H_0 and F_0 . By continuity they will be dependent at every point of the trajectory $\Gamma(0)$. Consequently,

$$\text{rank } \frac{\partial(H_0, F_0)}{\partial(I, \varphi)} \leq 1$$

at the points $(I, \varphi) \in \Gamma(0)$. In particular, at these points

$$\det \left(\frac{\partial(H_0, F_0)}{\partial(I_1, I_2)} \right) = 0.$$

To complete the proof it remains to observe that the functions H_0 and F_0 are independent of φ . ▷

For small fixed values of the parameter $\varepsilon \neq 0$, Theorem 7.4 guarantees the existence of a large (but finite) number of different isolated periodic solutions. Therefore from this theorem one cannot derive the non-integrability of the perturbed system for fixed values of $\varepsilon \neq 0$. However, in the case of two degrees of freedom, which is what we are now considering, the following assertion holds: if the unperturbed system is non-degenerate, then for fixed small values of $\varepsilon \neq 0$ the perturbed Hamiltonian system has infinitely many different periodic solutions. Unfortunately, they may not be isolated. The existence of infinitely many periodic solutions can be derived from Kolmogorov’s theorem on conservation of conditionally periodic motions (§ 6.3.2) and the *Poincaré–Birkhoff geometric theorem* (see [10]).

7.1.3 Applications of Poincaré’s Method

a) We turn to the restricted three-body problem, which was considered in § 2.5. First suppose that Jupiter’s mass μ is equal to zero. Then in the “fixed” space the asteroid will rotate in Keplerian orbits around the Sun of unit mass. Suppose that the orbits are ellipses. Then it is convenient to pass from rectilinear coordinates to the Delaunay canonical elements L, G, l, g (see Example 5.4 in § 5.2.1). In the new coordinates the equations of motion of the asteroid are canonical with the Hamiltonian function $F_0 = -1/(2L^2)$. If $\mu \neq 0$, then the full Hamiltonian F can be expanded in a series in the increasing powers of μ : $F = F_0 + \mu F_1 + \dots$. Since in the moving coordinate system attached to the Sun and Jupiter the Keplerian orbits rotate with unit angular velocity, the Hamiltonian function F depends on L, G, l , and $g - t$. We set $x_1 = L, x_2 = G, y_1 = l, y_2 = g - t$, and $H = F - G$. The function H now depends only on the x_i, y_i and is 2π -periodic in the angle variables y_1, y_2 . As a result, we represented the equations of motion of the asteroid in the form of the following Hamiltonian system:

$$\begin{aligned} \dot{x}_i &= \frac{\partial H}{\partial y_i}, & \dot{y}_i &= -\frac{\partial H}{\partial x_i}; \\ H &= H_0 + \mu H_1 + \dots, & H_0 &= -\frac{1}{2x_1^2} - x_2. \end{aligned} \tag{7.6}$$

The expansion of the perturbing function in the multiple trigonometric series in the angles y_1 and y_2 was studied already by Leverrier (see, for example, [20]). It has the following form:

$$H_1 = \sum_{u=-\infty}^{\infty} \sum_{v=-\infty}^{\infty} h_{u,v} \cos [uy_1 - v(y_1 + y_2)].$$

The coefficients $h_{u,v}$ depending on x_1 and x_2 are in general non-zero.

The Poincaré set of this problem consists of the straight lines parallel to the x_2 -axis given by $u/x_1^3 - v = 0, h_{u,v} \neq 0$. They fill everywhere densely the half-plane $x_1 > 0$. However, Theorem 7.1 on the absence of new analytic integrals cannot be applied directly because the unperturbed problem is degenerate: $\det (\partial^2 H_0 / \partial x^2) \equiv 0$. This difficulty is overcome by using the fact that the canonical equations with the Hamiltonians H and $\exp H$ have the same trajectories (but not the same solutions). Consequently, these equations are simultaneously integrable or not. It remains to observe that

$$\exp H = \exp H_0 + \mu(\exp H_0)H_1 + \dots \quad \text{and} \quad \det \left(\frac{\partial^2 \exp H_0}{\partial x^2} \right) \neq 0.$$

Thus, we have obtained that the equations of the restricted three-body problem in the form (7.6) do not have an integral $\Phi = \sum \Phi_s \mu^s$ that is independent

of the function H , is formally analytic in the parameter μ , and whose coefficients are smooth functions on the set $D \times \mathbb{T}^2\{y \bmod 2\pi\}$, where D is an arbitrary fixed domain in the half-plane $x_1 > 0$.

b) “Let us proceed to another problem; that of the motion of a heavy body about a fixed point. . . We can therefore ask if, in this problem, the considerations presented in this chapter oppose the existence of a uniform integral other than those of the *vis viva* and of area.” (Poincaré, [41], § 86).

To the symmetry group of rotations of the body around the vertical straight line there corresponds the linear integral $\langle k, \gamma \rangle$: the projection of the angular momentum onto the vertical is constant. By fixing this constant we reduce the number of degrees of freedom to two. On the four-dimensional integral levels $M_c = \{\langle k, \gamma \rangle = c, \langle \gamma, \gamma \rangle = 1\}$ we obtain a Hamiltonian system with two degrees of freedom. Its Hamiltonian function – the total energy of the body with a fixed value of the projection $\langle k, \gamma \rangle$ – is equal to $H_0 + \varepsilon H_1$, where H_0 is the kinetic energy (the Hamiltonian function of the integrable Euler problem of the free motion of the body) and H_1 is the potential energy of the body in a homogeneous gravitational field (ε is the product of the body’s weight and the distance from the centre of mass to the suspension point). We assume the parameter ε to be small (cf. § 6.2.1, Example 6.14). This is equivalent to studying rapid rotations of the body in a moderate force field. In the unperturbed integrable Euler problem we can introduce the action–angle variables I, φ . The transition formulae from the special canonical variables L, G, l, g to the action–angle variables I, φ can be found, for example, in [27]. In the new variables we have $H = H_0(I) + \varepsilon H_1(I, \varphi)$. The action variables I_1, I_2 can vary in the domain $\Delta = \{|I_1| \leq I_2\}$. The Hamiltonian $H_0(I_1, I_2)$ is a homogeneous function of degree 2, which is analytic in each of the four connected subdomains of Δ into which the domain Δ is divided by the three straight lines π_1, π_2 , and $I_1 = 0$. The straight lines π_1 and π_2 are given by the equation $2H_0/I_2^2 = A_2^{-1}$. They are symmetric with respect to the vertical axis and tend to the straight line $I_1 = 0$ as $A_2 \rightarrow A_1$, and to the pair of straight lines $|I_1| = I_2$ as $A_2 \rightarrow A_3$ (recall that A_1, A_2, A_3 are the principal inertia moments of the body and $A_1 \geq A_2 \geq A_3$). The level lines of the function H_0 are depicted in Fig. 7.1.

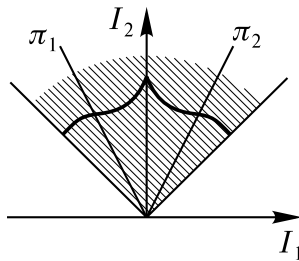

Fig. 7.1.

The expansion of the perturbing function H_1 in the multiple Fourier series in the angle variables φ_1 and φ_2 is in fact contained in one of Jacobi's papers:

$$\sum_{m \in \mathbb{Z}} h_{m,1} e^{i(m\varphi_1 + \varphi_2)} + \sum_{m \in \mathbb{Z}} h_{m,-1} e^{i(m\varphi_1 - \varphi_2)} + \sum_{m \in \mathbb{Z}} h_{m,0} e^{im\varphi_1}.$$

When the principal inertia moments satisfy the inequality $A_1 > A_2 > A_3$, the Poincaré set consists of infinitely many straight lines passing through the point $I = 0$ and accumulating at the pair of straight lines π_1 and π_2 . One can show that the function H_0 is non-degenerate in the domain Δ . If the function H were analytic in I in the entire domain Δ , then it would be possible to apply the results of § 7.1.1: the points I^0 lying on the straight lines π_1 and π_2 would satisfy the conditions of Theorem 7.1. The difficulty connected with analytic singularities of the Hamiltonian function in the action-angle variables can be overcome by considering the problem of an additional integral that is analytic on the entire integral level M_c . Using Poincaré's method one can prove the following.

Theorem 7.5 ([27]). *If a heavy rigid body is dynamically asymmetric, then the equations of rotation do not have a formal integral $\sum F_s \varepsilon^s$ that is independent of the function $H_0 + \varepsilon H_1$ and whose coefficients are analytic on the level M_c .*

This assertion gives a negative answer to the question stated by Poincaré in [41], § 86.

7.2 Splitting of Asymptotic Surfaces

Non-degenerate unstable periodic solutions have asymptotic manifolds filled with trajectories approaching periodic trajectories either as $t \rightarrow +\infty$ or as $t \rightarrow -\infty$. In integrable Hamiltonian systems these surfaces, as a rule, coincide pairwise. In non-integrable cases the situation is different: the asymptotic surfaces may intersect without coinciding and form in the intersection a rather tangled network (see Fig. 6.28). In this section we describe Poincaré's method for proving non-integrability based on analysis of asymptotic surfaces of nearly integrable Hamiltonian systems.

7.2.1 Splitting Conditions. The Poincaré Integral

Let V be a smooth n -dimensional configuration space of a Hamiltonian system, T^*V its phase space, and $H: T^*V \times \mathbb{R}\{t\} \rightarrow \mathbb{R}$ the Hamiltonian function. In the extended phase space $M = T^*V \times \mathbb{R}^2$ (where \mathbb{R}^2 is the plane with coordinates E, t) the equations of motion are again Hamiltonian:

$$\dot{x} = \frac{\partial K}{\partial y}, \quad \dot{y} = -\frac{\partial K}{\partial x}, \quad \dot{E} = \frac{\partial K}{\partial t}, \quad \dot{t} = -\frac{\partial K}{\partial E}, \quad (7.7)$$

where $K = H(y, x, t) - E$, $x \in V$, $y \in T_x^*V$.

A smooth surface $\Lambda^{n+1} \subset M$ is said to be *Lagrangian* if

$$\oint_{\gamma} (y \, dx - E \, dt) = 0$$

for any closed contractible curve γ , where $E = H(y, x, t)$ on the surface Λ^{n+1} . Lagrangian surfaces remain Lagrangian under the action of the phase flow of system (7.7). In the autonomous case Lagrangian surfaces $\Lambda^n \subset T^*V$ are defined by the condition

$$\oint_{\gamma} y \, dx = 0.$$

If a Lagrangian surface Λ^{n+1} is uniquely projected by the natural projection $(y, x, t) \mapsto (x, t)$ onto $D \times \mathbb{R}\{t\}$, $D \subset V$, and at each of its points is transversal to the fibre of the projection, then it can be represented as a graph

$$y = \frac{\partial S(x, t)}{\partial x}, \quad H(y, x, t) = -\frac{\partial S(x, t)}{\partial t},$$

where $S: D \times \mathbb{R} \rightarrow \mathbb{R}$ is some smooth function. In the autonomous case Λ^n is given by the graph

$$y = \frac{\partial S}{\partial x}, \quad x \in D.$$

The function $S(x, t)$ satisfies the Hamilton–Jacobi equation:

$$\frac{\partial S}{\partial t} + H\left(\frac{\partial S}{\partial x}, x, t\right) = 0.$$

In this section we deal with Lagrangian surfaces composed of asymptotic trajectories. It is natural to call such surfaces *asymptotic surfaces*.

Suppose that the Hamiltonian function is 2π -periodic in t and depends on some parameter ε : $H = H(y, x, t, \varepsilon)$. Suppose that for $\varepsilon = 0$ the function $H(y, x, t, 0) = H_0(y, x)$ is independent of time and satisfies the following conditions:

1) There exist two critical points y_-, x_- and y_+, x_+ of the function H_0 at which the eigenvalues of the linearized Hamiltonian system

$$\dot{y} = -\frac{\partial H_0}{\partial x}, \quad \dot{x} = \frac{\partial H_0}{\partial y}$$

are real and non-zero. In particular, the 2π -periodic solutions $x_{\pm}(t) = x_{\pm}$, $y_{\pm}(t) = y_{\pm}$ are hyperbolic.

2) If Λ^+ (or Λ^-) is the stable (respectively, unstable) asymptotic manifold in T^*V passing through the point x_+, y_+ (respectively, x_-, y_-), then $\Lambda^+ = \Lambda^-$. Hence, in particular, $H_0(y_+, x_+) = H_0(y_-, x_-)$.

3) There exists a domain $D \subset V$ containing the points x_{\pm} such that in $T^*D \subset T^*V$ the equation of the surface $\Lambda^+ = \Lambda^-$ can be represented in the form $y = \partial S_0 / \partial x$, where S_0 is some analytic function in the domain D . It is useful to consider the differential equation

$$\dot{x} = \frac{\partial H_0}{\partial y} \Big|_{y(x)}, \quad y = \frac{\partial S_0}{\partial x}. \tag{7.8}$$

In a small neighbourhood of the point x_{\pm} the solutions of this equation tend to the point x_{\pm} as $t \rightarrow \pm\infty$.

4) In the domain D , equation (7.8) has a doubly asymptotic solution: $x_0(t) \rightarrow x_{\pm}$ as $t \rightarrow \pm\infty$ (Fig. 7.2).

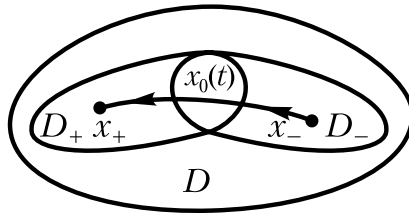

Fig. 7.2.

The Hamiltonian system with Hamiltonian function H_0 should be regarded as unperturbed. In applications this system is usually completely integrable. Let D_+ (D_-) be a subdomain of the domain D containing the point x_+ (respectively, x_-) and not containing x_- (respectively, x_+). For small values of ε the asymptotic surfaces Λ^+ and Λ^- do not disappear but become the “perturbed” surfaces Λ_{ε}^+ and Λ_{ε}^- . More precisely, in the domain $D_{\pm} \times \mathbb{R}\{t\}$ the equation of the asymptotic surface can be represented in the form

$$y = \frac{\partial S^{\pm}}{\partial x},$$

where $S^{\pm}(x, t, \varepsilon)$ is 2π -periodic in t and is defined and analytic for $x \in D_{\pm}$ and for small values of ε (Poincaré, [41]). The function S^{\pm} satisfies the Hamilton–Jacobi equation

$$\frac{\partial S^{\pm}}{\partial t} + H \left(\frac{\partial S^{\pm}}{\partial x}, x, t, \varepsilon \right) = 0. \tag{7.9}$$

According to our assumption, the surfaces Λ_0^+ and Λ_0^- coincide for $\varepsilon = 0$. Poincaré observed [41] that in general for small values of the parameter $\varepsilon \neq 0$ the surfaces Λ_0^+ and Λ_0^- , regarded as sets of points in $T^*(D_+ \cap D_-) \times \mathbb{R}$, no longer coincide. This phenomenon is called *splitting of asymptotic surfaces*. Clearly, Λ_{ε}^+ coincides with Λ_{ε}^- if and only if equation (7.9) has a solution $S(x, t, \varepsilon)$ that is analytic in x in the entire domain D .

Theorem 7.6 (Poincaré). *If $H_1(y_+, x_+, t) = H_1(y_-, x_-, t)$ and*

$$\int_{-\infty}^{+\infty} \{H_0, H_1\}(y(x_0(t)), x_0(t), t) dt \neq 0, \tag{7.10}$$

then for small values of the parameter $\varepsilon \neq 0$ the perturbed asymptotic surfaces Λ_ε^+ and Λ_ε^- do not coincide.

◁ Suppose that equation (7.9) has an analytic solution $S(x, t, \varepsilon)$ which, for small values of ε , can be represented in the form of a convergent power series

$$S = S_0(x, t) + \varepsilon S_1(x, t) + \dots .$$

The function S_0 must satisfy the equation

$$\frac{\partial S_0}{\partial t} + H_0 \left(\frac{\partial S_0}{\partial x}, x \right) = 0.$$

Hence, $S_0 = -ht + W(x)$, where $h = H_0(y_\pm, x_\pm)$ and W is a solution of the equation

$$H_0 \left(\frac{\partial W}{\partial x}, x \right) = h.$$

It is clear that W coincides with the function $S_0(x)$.

Let $H = H_0(y, x) + \varepsilon H_1(y, x, t) + \dots$. Then from (7.9) we obtain the quasi-linear differential equation for S_1

$$\frac{\partial S_1}{\partial t} + \frac{\partial H_0}{\partial x} \Big|_{y(x)} \frac{\partial S_1}{\partial x} + H_1(y(x), x, t) = 0. \tag{7.11}$$

Since equation (7.8) is autonomous, together with the solution $x_0(t)$ it has the family of solutions $x_0(t + \alpha)$, $\alpha \in \mathbb{R}$. It follows from (7.11) that on these solutions we have

$$\begin{aligned} S_1(x_0(t + \alpha), t) \\ = S_1(x_0(\alpha), 0) - \int_0^t H_1(y(x_0(t + \alpha)), x_0(t + \alpha), t) dt. \end{aligned} \tag{7.12}$$

We can assume without loss of generality that $H_1(y_\pm, x_\pm, t) = 0$ for all t . If this is not the case, then the perturbing function should be replaced by the function $H_1 - H_1(y_\pm, x_\pm, t)$. This does not affect the Poisson bracket $\{H_0, H_1\}$.

Since the Taylor expansion of the function H_1 about the points x_\pm, y_\pm begins with linear terms in $x - x_\pm, y - y_\pm$, and the functions $x_0(t) - x_\pm, y(x_0(t)) - y_\pm$ tend to zero exponentially fast as $t \rightarrow \pm\infty$, the integral

$$J(\alpha) = \int_{-\infty}^{+\infty} H_1(y_0(t + \alpha), x_0(t + \alpha), t) dt \tag{7.13}$$

converges. Equation (7.12) also implies that the value of $S_1(x, t)$ at the points x_{\pm} is independent of t . According to (7.12), the integral $J(\alpha)$ is equal to $S_1(x_+) - S_1(x_-)$ and therefore is independent of α . To complete the proof it remains to calculate the derivative

$$\left. \frac{dJ}{d\alpha} \right|_{\alpha=0} = \int_{-\infty}^{+\infty} \sum \left(\frac{\partial H_1}{\partial x_s} \dot{x}_s + \frac{\partial H_1}{\partial y_s} \dot{y}_s \right) dt = \int_{-\infty}^{+\infty} \{H_0, H_1\} dt = 0. \quad \triangleright$$

Another proof of Poincaré's theorem can be found in [8].

Theorem 7.6 is also valid without hypothesis 3). In this case hypothesis 4) is replaced with the assumption that the unperturbed system has a doubly asymptotic solution $t \mapsto (x_0(t), y_0(t))$, $t \in \mathbb{R}$, with $(x_0(t), y_0(t)) \rightarrow (x_{\pm}, y_{\pm})$ as $t \rightarrow \pm\infty$. In (7.10) one should replace $y(x_0(t))$ with $y_0(t)$. In this form, Theorem 7.6 is also valid for the case where the points (x_+, y_+) and (x_-, y_-) coincide.

Non-Hamiltonian perturbations were considered in [420]. In this case, the splitting of asymptotic surfaces in the first approximation in ε is determined by an integral that is similar to (7.10), where the integrand is equal to the derivative of H_0 along the perturbing vector field. Now such integrals are usually called the *Poincaré–Mel'nikov integrals*.

In the autonomous case, the condition for splitting of asymptotic surfaces situated on some fixed energy level can be represented in the form

$$\int_{-\infty}^{+\infty} \{F_0, H_1\} dt \neq 0, \quad (7.14)$$

where F_0 is an integral of the unperturbed system. If $dF_0 = 0$ at the points of unstable periodic trajectories, then the integral (7.14) converges automatically.

The function $J(\alpha)$ (see (7.13)) is usually referred to as the *Poincaré integral*. In the case of one and a half degrees of freedom, the separatrix splitting in the first approximation in ε is completely determined by $J(\alpha)$; see [590].

This statement can be explained as follows. Suppose that $n = 1$, while $x_+ = x_-$ and $y_+ = y_-$. Let A_T be a compact piece of the unperturbed separatrix

$$A_T = \{(x, y) \in T^*D: y = \partial S_0 / \partial x, x = x_0(t), |t| \leq T\}.$$

Then for any $T > 0$ there exists a neighborhood U of A_T and symplectic coordinates (time-energy coordinates) τ, h on U such that the section of the perturbed separatrices $A_{\varepsilon}^{s,u}$ by the plane $\{t = 0\}$ is as follows:

$$A_{\varepsilon}^{s,u}|_{t=0} = \{(\tau, h): h = h_{\varepsilon}^{s,u}(\tau)\},$$

where

- i) $h_\varepsilon^u(\tau) = O(\varepsilon^2)$,
- ii) $h_\varepsilon^s(\tau) = \varepsilon dJ(\tau)/d\tau + O(\varepsilon^2)$.

Moreover, let $g_\varepsilon^{2\pi} : T^*V \rightarrow T^*V$ be the shift map by time 2π starting at the instant $t = 0$ for the perturbed system (the Poincaré map). The following statement holds.

- iii) For any two points $z_0, z_1 \in U$ such that $z_1 = g_\varepsilon^{2\pi}(z_0)$ let (τ_0, h_0) and (τ_1, h_1) be their time-energy coordinates. Then

$$\tau_1 = \tau_0 + 2\pi + O(\varepsilon), \quad h_1 = h_0 + O(\varepsilon).$$

The existence of such coordinates has several corollaries.

A. If J is not identically constant, then the separatrices split and this splitting is of the first order in ε .

B. Let τ_* be a non-degenerate critical point of J . Then the perturbed separatrices intersect transversally at a point $z_*(\varepsilon)$ with time-energy coordinates $(\tau_* + O(\varepsilon), O(\varepsilon^2), t = 0)$. Such a point $z_*(\varepsilon)$ is called a transversal homoclinic point. It generates a doubly asymptotic solution in the perturbed system.

C. Consider a lobe domain $\mathcal{L}(\tau_*, \varepsilon)$ bounded by two segments of separatrices on the section $\{t = 0\}$ (see Fig. 7.3). Let the “corner points” of the lobe $\mathcal{L}(\tau_*, \varepsilon)$ correspond to the non-degenerate critical points τ_* and τ'_* of J . Then the symplectic area of $\mathcal{L}(\tau_*, \varepsilon)$ is equal to

$$\mathcal{A}\mathcal{L}(\tau_*, \varepsilon) = \varepsilon(J(\tau'_*) - J(\tau_*)) + O(\varepsilon^2).$$

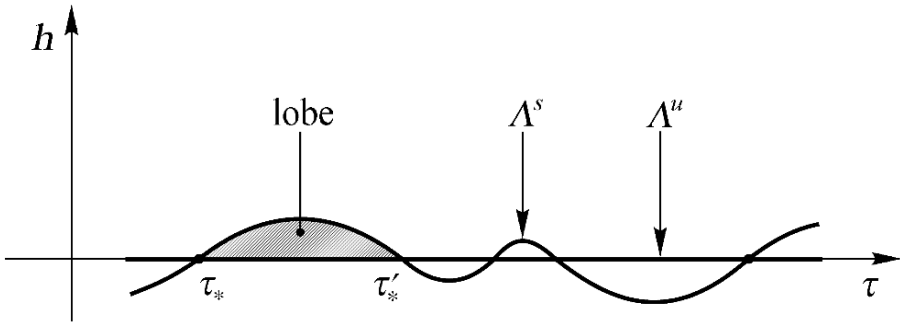

Fig. 7.3. Perturbed separatrices in the time-energy coordinates

7.2.2 Splitting of Asymptotic Surfaces as an Obstruction to Integrability

We consider a Hamiltonian system with Hamiltonian

$$H(z, t, \varepsilon) = H_0(z) + \varepsilon H_1(z, t) + O(\varepsilon^2)$$

under the assumptions of § 7.2.1. In particular, the unperturbed system has two hyperbolic equilibria z_{\pm} connected by a doubly asymptotic solution $t \mapsto z_0(t)$, $t \in \mathbb{R}$.

Theorem 7.7 (Bolotin, [125]). *Suppose that the following conditions hold:*

- 1) $\int_{-\infty}^{+\infty} \{H_0, \{H_0, H_1\}\}(z_0(t), t) dt \neq 0$,
- 2) for small ε the perturbed system has a doubly asymptotic solution $t \mapsto z_{\varepsilon}(t)$ close to $t \mapsto z_0(t)$.

Then for small fixed values of $\varepsilon \neq 0$ Hamilton's equations $\dot{z} = I dH$ do not have a complete set of independent integrals in involution in any neighbourhood of the closure of the trajectory $z_{\varepsilon}(t)$.

Remark 7.2. Condition 1) can be replaced by the following condition: for some $m \geq 2$,

$$\int_{-\infty}^{+\infty} \underbrace{\{H_0, \dots, \{H_0, H_1\} \dots\}}_m(z_0(t), t) dt \neq 0.$$

If condition 1) holds, then the asymptotic surfaces certainly do not coincide. Of course, condition 2) does not always hold. We now give a sufficient condition for the existence of a family of doubly asymptotic trajectories.

Let $H_0 = F_1, \dots, F_n$ be commuting integrals of the unperturbed problem which are independent on $\Lambda_0^+ = \Lambda_0^-$. If

$$\int_{-\infty}^{+\infty} \{F_i, H_1\}(z_0(t), t) dt = 0, \quad \text{and}$$

$$\det \left(\int_{-\infty}^{+\infty} \{F_i, \{F_j, H_1\}\}(z_0(t), t) dt \right) \neq 0,$$

then there exists a family of asymptotic solutions $t \mapsto z_{\varepsilon}(t)$ analytic in ε . This assertion can be easily derived from the implicit function theorem.

If we are studying the problem of the existence of independent involutive integrals $F_i(z, t, \varepsilon)$, $1 \leq i \leq n$, that are analytic (or formally analytic) in the parameter ε , then condition 2) can be dropped. In particular, if condition 1)

holds, then the series of perturbation theory are divergent in a neighbourhood of the split asymptotic surfaces.

Using the method of Birkhoff normal forms one can find, in a neighbourhood of the unstable periodic solutions $z_{\pm} + O(\varepsilon)$, a formal canonical change of variables $z \mapsto u$ which is 2π -periodic in t and reduces the Hamiltonian function $H(z, t, \varepsilon)$ to a function $H^{\pm}(u, \varepsilon)$ independent of t . Because the characteristic exponents are commensurable, this Birkhoff transformation may be divergent. But in the case of one degree of freedom ($n = 1$) the formal series of the change of variables $z \mapsto u$ always converge and depend analytically on the parameter ε (see [435]).

Theorem 7.8. *Suppose that the Birkhoff transformation converges and depends analytically on ε . If condition 1) of Theorem 7.7 is satisfied, then for small $\varepsilon \neq 0$ Hamilton's equations do not have a complete set of independent analytic integrals in involution.*

In particular, for $n = 1$ condition 1) is a sufficient condition for non-integrability (Ziglin [625]).

◁ *Proof of Theorem 7.8.* We define functions R^{\pm} on the surfaces A_0^{\pm} by the formulae

$$R^+(z) = - \int_0^{+\infty} \{H_0, \{H_0, H_1\}\} (z(t), t) dt,$$

$$R^-(z) = \int_{-\infty}^0 \{H_0, \{H_0, H_1\}\} (z(t), t) dt,$$

where $t \mapsto z(t)$ is the asymptotic motion of the unperturbed system with the initial condition $z(0) = z$.

Lemma 7.2. *The functions R^{\pm} are determined by the function H_0 , the family of surfaces A_{ε}^{\pm} , and the symplectic structure.*

◁ Indeed, according to the results of §7.2.1 the functions

$$S^+(z) = -\varepsilon \int_0^{+\infty} (H_1(z(t), t) - H_1(z_+, t)) dt,$$

$$S^-(z) = \varepsilon \int_{-\infty}^0 (H_1(z(t), t) - H_1(z_-, t)) dt$$

are generating functions of the Lagrangian surfaces A_{ε}^{\pm} to within $O(\varepsilon^2)$. But $\varepsilon R^{\pm} = \{H_0, \{H_0, S^{\pm}\}\}$. ▷

The compositions of the Birkhoff transformation with powers of the map over the period allow one to continue the functions H^\pm from neighbourhoods of the critical points $u_\pm(\varepsilon)$ to some neighbourhoods W_\pm of the asymptotic surfaces Λ_ε^\pm . Since a possible splitting of the surfaces Λ_ε^+ and Λ_ε^- is of order ε , for small ε the neighbourhoods W_+ and W_- intersect.

Lemma 7.3. *We have $\{H^+, H^-\} \neq 0$ for $\varepsilon \neq 0$.*

◁ We set

$$H^\pm(u, \varepsilon) = H^\pm(u) + \varepsilon H_1^\pm(u) + O(\varepsilon^2).$$

Since $H_0^\pm(u) = H_0(u)$, we have

$$\{H^+, H^-\} = \varepsilon\{H_0, H_1^- - H_1^+\} + O(\varepsilon^2).$$

Because Λ_0^- is an invariant asymptotic manifold of the Hamiltonian system $\dot{u} = IdH_0$, by Lemma 7.2 we have

$$\{H_0, H_1^-\}(u) = \int_{-\infty}^0 \{H_0, \{H_0, H_1^-\}\}(u_0(t)) dt = R^-(u), \quad u \in \Lambda_0^-.$$

Similarly,

$$\{H_0, H_1^+\}(u) = \int_0^{+\infty} \{H_0, \{H_0, H_1^+\}\}(u_0(t)) dt = R^+(u), \quad u \in \Lambda_0^+.$$

Consequently,

$$\{H^+, H^-\} = \varepsilon \int_{-\infty}^{+\infty} \{H_0, \{H_0, H_1\}\}(z_0(t), t) dt + O(\varepsilon^2).$$

By condition 1), for small $\varepsilon \neq 0$ the Poisson bracket satisfies the conclusion: $\{H^+, H^-\} \neq 0$. ▷

Completion of the proof of Theorem 7.8. In the new variables u , the integrals F_1, \dots, F_n are independent of t . Suppose that for $\varepsilon \neq 0$ the integrals F_1, \dots, F_n are independent at some point of $W_+ \cap W_-$. Since $\{H^\pm, F_i\} \equiv 0$, the vector IdH^\pm is a linear combination of the vectors IdF_i . Because $\{F_i, F_j\} = 0$, we clearly have $\{H^+, H^-\} = 0$ at this point. To complete the proof it remains to observe that the analytic function $\{H^+, H^-\}$ does not vanish on an everywhere dense set. ▷

Theorem 7.9. *Let $n = 1$. If*

- 1) $\int_{-\infty}^{+\infty} \{H_0, H_1\}(z_0(t), t) dt \neq 0$, and

2) for small ε the perturbed system has a doubly asymptotic solution $t \mapsto z_\varepsilon(t)$ close to $t \mapsto z_0(t)$,

then for small values of $\varepsilon \neq 0$ the Hamiltonian system $\dot{z} = IdH$ does not have an additional analytic integral.

◁ Consider the flow map g over the period from the section $t = t_0$ onto itself. For small ε this map has two hyperbolic fixed points z_1 and z_2 with invariant separatrices W_1^\pm and W_2^\pm . According to the hypotheses of the theorem, for $\varepsilon \neq 0$ the separatrices W_1^+ and W_2^- intersect and do not coincide. Let V be a small neighbourhood of the point z_1 , and Δ a small segment of the separatrix W_2^- intersecting W_1^+ . For sufficiently large n the segment $g^n(\Delta)$ is entirely contained in the domain V and again intersects W_1^+ . According to the *Grobman–Hartman theorem* [481], in the domain V the map g is topologically conjugate to a linear hyperbolic rotation. Consequently, as $n \rightarrow \infty$, the segments $g^n(\Delta)$ will be “stretched” along the separatrix W_1^- approaching it arbitrarily closely. It is obvious that the union

$$\bigcup_{n=1}^{\infty} g^n(\Delta) \tag{7.15}$$

is a key set for the class of functions analytic in the section $t = t_0$.

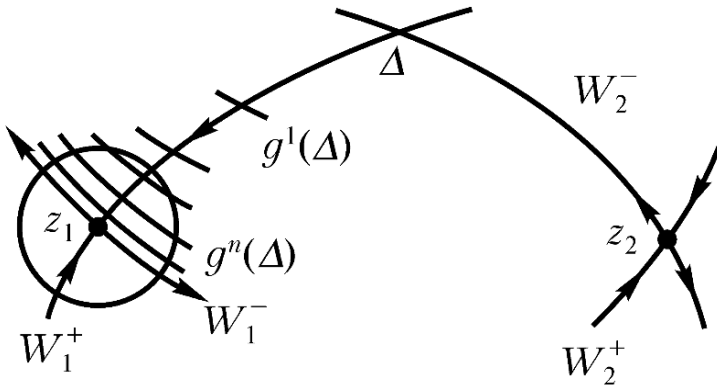

Fig. 7.4.

Now suppose that Hamilton’s equation has an analytic integral $f(z, t)$. The function $f(z, t_0)$ is invariant under the map g and is constant on the separatrix W_2^- (since the sequence of points $g^n(z)$, $z \in W_2^-$, converges to the point z_2 as $n \rightarrow -\infty$). Consequently, the analytic function $f(z, t_0)$ is constant on the set (7.15) and therefore is constant for any t_0 . ▷

Remark 7.3. Poincaré divided doubly asymptotic solutions into two types: *homoclinic* (when $z_+ = z_-$) and *heteroclinic* (when $z_+ \neq z_-$). If $n = 1$, then for small ε the perturbed problem always has homoclinic solutions (of course, if they existed for $\varepsilon = 0$).

7.2.3 Some Applications

a) First we consider the simplest problem of the oscillations of a pendulum with a vibrating point of suspension (see §6.1.4, Example 6.6). The Hamiltonian function H is equal to $H_0 + \varepsilon H_1$, where

$$H_0 = \frac{y^2}{2} - \omega^2 \cos x, \quad H_1 = -\omega^2 f(t) \cos x,$$

and f is a 2π -periodic function of time. When $\varepsilon = 0$, the upper position of the pendulum is an unstable equilibrium. The unperturbed problem has two families of homoclinic solutions:

$$\cos x_0 = \frac{2e^{\pm\omega(t-t_0)}}{e^{\pm 2\omega(t-t_0)} + 1}, \quad x_0 \rightarrow \pm\pi \quad \text{as} \quad t \rightarrow \pm\infty. \quad (7.16)$$

Since $\{H_0, H_1\} = -\omega^2 f(t) \dot{x} \sin x$, the integral (7.10) is, up to a constant factor, equal to

$$\int_{-\infty}^{+\infty} \dot{f}(t) \cos x_0 dt.$$

Let $f(t) = \sum f_n e^{int}$. Then the integral (7.10) can be represented as the series

$$\sum_{n \in \mathbb{Z}} 2in f_n J_n e^{int_0}, \quad J_n = \int_{-\infty}^{+\infty} \frac{e^{\pm\omega t} e^{int}}{e^{\pm 2\omega t} + 1} dt.$$

The integrals J_n can be easily calculated by using residues:

$$J_n = \frac{-ie^{-n\pi/2\omega}}{2\omega(1 + e^{\pm n\pi/\omega})} \neq 0.$$

Consequently, if $f(t) \neq \text{const}$ (that is, $f_n \neq 0$ for some $n \neq 0$), then the integral (7.10) is distinct from zero on at least one doubly asymptotic solution in the family (7.16). Thus, if $f(t) \neq \text{const}$, then according to the results of §7.2.2, for sufficiently small (but fixed) values of the parameter $\varepsilon \neq 0$ the problem does not have an analytic first integral $F(y, x, t)$ that is 2π -periodic in x and t . One can show that the equations of oscillations of the pendulum can be completely integrable only for finitely many values of the parameter ε in the interval $[-a, a]$, where $a = 1/\max |f(t)|$ (see [28]).

Remark 7.4. The paper [28] contains an example of a Hamiltonian system with analytic Hamiltonian depending analytically on the parameter, for which there are two everywhere dense sets of values of the parameter on one of which the system is completely integrable, and on the other non-integrable. Thus, the integrable cases are not always isolated.

b) In the problem of the rapid rotation of a heavy asymmetric rigid body, the Hamiltonian function is $H = H_0 + \varepsilon H_1$, where $H_0 = \langle \mathbf{AM}, \mathbf{M} \rangle / 2$, $H_1 = \langle \mathbf{x}, \mathbf{e} \rangle$; $A = \text{diag}(a_1, a_2, a_3)$, $\mathbf{x} = (x_1, x_2, x_3)$. The numbers a_1, a_2, a_3 are the reciprocals of the principal moments of inertia of the body, and x_1, x_2, x_3 are the coordinates of the centre of mass with respect to the principal inertia axes. For $\varepsilon = 0$ we have the integrable Euler case. In this unperturbed problem, on every regular three-dimensional level

$$M_{h,c} = \{ \mathbf{M}, \mathbf{e}: H_0 = h, \langle \mathbf{M}, \mathbf{e} \rangle = c, \langle \mathbf{e}, \mathbf{e} \rangle = 1 \}$$

there exist two unstable periodic solutions: if $a_1 < a_2 < a_3$, then these solutions are given by

$$\begin{aligned} M_1 = M_3 = 0, \quad M_2 = M_2^0 = \pm \sqrt{\frac{2h}{a_2}}; \\ e_2 = e_2^0 = \pm \frac{c}{M_2^0}, \quad e_1 = \alpha \cos(a_2 M_2^0 t), \quad e_3 = \alpha \sin(a_2 M_2^0 t); \quad (7.17) \\ \alpha^2 = 1 - \left(\frac{c}{M_2^0} \right)^2 \end{aligned}$$

The inequality $\langle \mathbf{M}, \mathbf{e} \rangle^2 \leq \langle \mathbf{M}, \mathbf{M} \rangle \cdot \langle \mathbf{e}, \mathbf{e} \rangle$ and the independence of the first integrals on $M_{h,c}$ imply that $\alpha^2 > 0$. The stable and unstable asymptotic surfaces of the periodic solutions (7.17) can be represented as the intersections of the manifold $M_{h,c}$ with the hyperplanes $M_1 \sqrt{a_2 - a_1} \pm M_3 \sqrt{a_3 - a_2} = 0$. In the Euler problem the asymptotic surfaces are “doubled”: they are completely filled with doubly asymptotic trajectories which approach the periodic trajectories (7.17) unboundedly as $t \rightarrow \pm\infty$. Splitting of these surfaces was studied in the papers of Kozlov (1976) and Ziglin (1980). It turned out that the asymptotic surfaces always split under a perturbation, except for the “Hess–Appel’rot case”:

$$x_2 = 0, \quad x_1 \sqrt{a_3 - a_2} \pm x_3 \sqrt{a_2 - a_1} = 0. \quad (7.18)$$

In this case, one pair of separatrices splits, and the other does not.

The reason for non-splitting is that when condition (7.18) holds, the perturbed problem for all values of ε has the “particular” integral

$$F = M_1 \sqrt{a_2 - a_1} \pm M_3 \sqrt{a_3 - a_2}$$

(since $\dot{F} = 0$ if $F = 0$). One can show that for small values of ε the closed invariant surfaces $M_{h,c} \cap \{F = 0\}$ form precisely a pair of doubled separatrices (see [27]).

In the problem of the rapid rotation of a heavy asymmetric top, the split separatrices, apparently, do not always intersect. However, here Theorem 7.8 is applicable, which can be used to establish the absence of an additional analytic integral of the perturbed problem for small but fixed values of the parameter $\varepsilon \neq 0$ (Ziglin, 1980).

The behaviour of solutions of the perturbed problem was studied numerically by Galgani, Giorgilli, and Strelcyn [239]. Fig. 7.5 shows the results of calculations for different values of the perturbing parameter ε . One can clearly see that the picture of invariant curves of the unperturbed problem starts to disintegrate precisely in a neighbourhood of the separatrices.

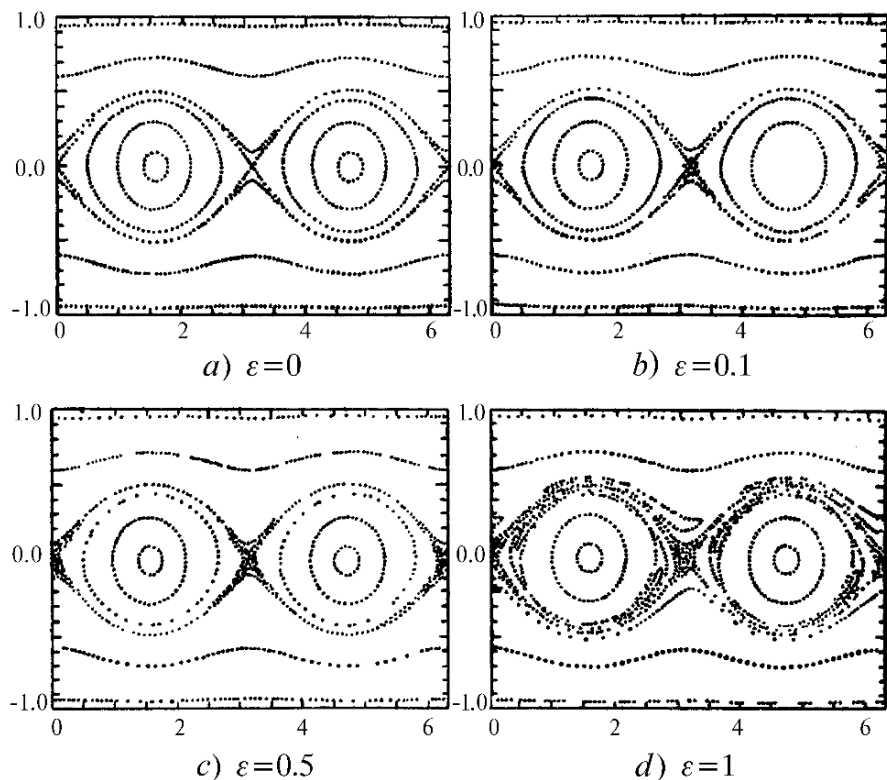

Fig. 7.5.

c) We now consider Kirchhoff's equations

$$\begin{cases} \dot{\mathbf{M}} = \mathbf{M} \times \boldsymbol{\omega} + \mathbf{e} \times \mathbf{u}, & \dot{\mathbf{e}} = \mathbf{e} \times \boldsymbol{\omega}; & \boldsymbol{\omega} = H'_M, & \mathbf{u} = H'_e, \\ H = \frac{1}{2} \langle \mathbf{A}\mathbf{M}, \mathbf{M} \rangle + \langle \mathbf{B}\mathbf{M}, \mathbf{e} \rangle + \frac{1}{2} \langle \mathbf{C}\mathbf{e}, \mathbf{e} \rangle, \end{cases} \quad (7.19)$$

describing the rotation of a rigid body in an ideal fluid.

We consider the case where the matrix A is diagonal, $A = \text{diag}(a_1, a_2, a_3)$, and the matrices B and C are symmetric.

Theorem 7.10. *Suppose that the numbers a_1, a_2, a_3 are pairwise distinct. If Kirchhoff's equations have an additional integral that is independent of the functions $F_1 = H$, $F_2 = \langle \mathbf{M}, \mathbf{e} \rangle$, $F_3 = \langle \mathbf{e}, \mathbf{e} \rangle$ and is analytic in $\mathbb{R}^6\{\mathbf{M}, \mathbf{e}\}$, then the matrix B is diagonal, $B = \text{diag}(b_1, b_2, b_3)$, and*

$$a_1^{-1}(b_2 - b_3) + a_2^{-1}(b_3 - b_1) + a_3^{-1}(b_1 - b_2) = 0. \quad (7.20)$$

If $B = 0$, then an independent analytic integral exists only in the case where $C = \text{diag}(c_1, c_2, c_3)$ and

$$a_1^{-1}(c_2 - c_3) + a_2^{-1}(c_3 - c_1) + a_3^{-1}(c_1 - c_2) = 0. \quad (7.21)$$

The matrix B in the Steklov integrable case is determined precisely by condition (7.20). Condition (7.21) gives the Clebsch integrable case. It is interesting that conditions (7.20) and (7.21) have the same form. In the Sokolov integrable case we have $a_1 = a_2$ and the symmetric matrix B is not diagonal.

Corollary 7.3. *In the general case Kirchhoff's equations are non-integrable.*

The proof of Theorem 7.10, which was established by Kozlov and Onishchenko [356], is also based on the phenomenon of separatrix splitting: a small parameter ε is introduced into equations (7.19) by replacing \mathbf{e} by $\varepsilon\mathbf{e}$; for $\varepsilon = 0$ we have again the integrable Euler problem, whose doubled separatrices split under perturbations if conditions (7.20)–(7.21) do not hold. The details can be found in [28, 30].

d) Using the method of splitting of asymptotic surfaces one can establish the non-integrability of the problem of motion of four point vortices (Ziglin [624]). More precisely, consider this problem in the restricted setting: a vortex of zero intensity (that is, simply a particle of the ideal fluid) is moving in the “field” of three vortices of equal intensities. It turns out that the equation of motion of the zero vortex can be represented in the Hamiltonian form with Hamiltonian that is periodic in time; these equations have hyperbolic periodic motions with intersecting separatrices. Therefore the restricted problem of four vortices is not completely integrable, although it has four independent non-commuting integrals (as in the unrestricted setting).

The non-integrable (chaotic) behaviour of the system of four point vortices of equal intensities was first indicated in [483] with the aid of numerical calculations. In more detail this problem was studied in [70].

7.3 Quasi-Random Oscillations

Most of the methods for proving non-integrability are based on the fact that a sufficiently intricate topological behaviour of the phase curves obstructs the

existence of first integrals. One of the cases where such topological intricacy (and therefore, non-integrability) can be established explicitly is the theory of *quasi-random oscillations*, which is considered here in the simplest model situation.

Following Alekseev we consider a non-autonomous system with one degree of freedom whose motion is described by the equation

$$\ddot{x} = -Q(x, t), \quad x \in \mathbb{R}. \quad (7.22)$$

We assume that the following conditions hold:

- a) Q is a smooth function 2π -periodic in t .
- b) $Q(-x, t) = -Q(x, t)$; in particular, $Q(0, t) = 0$ and, consequently, the point $x = 0$ is an equilibrium position.
- c) $Q > 0$ for $x > 0$, and

$$\int_0^\infty \int_0^{2\pi} Q(x, t) dx \wedge dt < \infty.$$

If the system is autonomous, then the last condition means that the potential energy is bounded as $|x| \rightarrow \infty$.

d) $Q'_x \leq 0$ for $x \geq x_* > 0$. This means that the graph of the potential energy $U(x, t)$ (defined by the equality $U'_x = -Q$ for $|x| > x_*$) is convex.

The following two conditions are of technical nature:

- e) $|Q'_t| \leq \Psi(x)$, $\int_0^\infty \Psi(x) dx < \infty$.
- f) $\Psi(x)/Q^2(x, t) = O(1)$ for $x \geq x_0$.

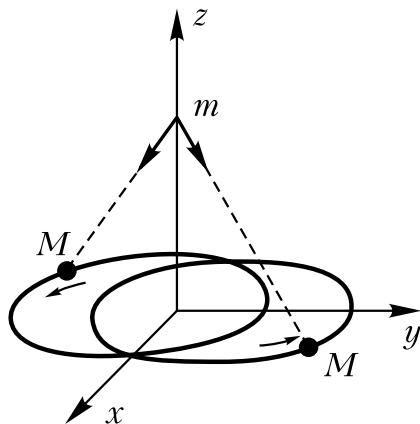

Fig. 7.6.

An important example is the variant of the restricted three-body problem in which two points of equal masses describe elliptic orbits in the plane x, y symmetric with respect to the z -axis, and the third point of zero mass always remains on the z -axis (see Fig. 7.6). The motion of the third point is described by the differential equation

$$\ddot{z} = -\frac{z}{[z^2 + r^2(t)]^{3/2}}, \tag{7.23}$$

where

$$r(t) = \frac{1}{1 + e \cos \varphi(t)}, \quad \dot{\varphi} = (1 + e \cos \varphi)^2, \quad \varphi(0) = 0;$$

here e is the eccentricity of the elliptic orbit of massive bodies. In this example all conditions a)–f) are obviously satisfied.

7.3.1 Poincaré Return Map

Definition 7.1. A solution $x(t)$ of equation (7.22) is said to be *hyperbolic in the future* if there exists $\dot{x}(+\infty) = \lim_{t \rightarrow +\infty} \dot{x}(t) > 0$; *parabolic in the future* if $\dot{x}(+\infty) = 0$, and *oscillating in the future* if the function $x(t)$ has infinitely many zeros as $t \rightarrow +\infty$.

These three forms of motion *in the past* (as $t \rightarrow -\infty$) are defined in similar fashion (see § 2.4.1).

In the above-mentioned example of the restricted three-body problem, the hyperbolic (parabolic) in the future motions are called according to Chazy hyperbolic-elliptic (parabolic-elliptic) motions. The oscillating in the future motions had not yet been defined as final motions.

Proposition 7.2. *Each solution of equation (7.22) is of one of these three types (both as $t \rightarrow +\infty$ and as $t \rightarrow -\infty$).*

An easy proof is based on using properties a)–c) of the function Q .

Let $x(t)$ be the solution of equation (7.22) with the initial data $x(\tau) = 0, \dot{x}(\tau) = v > 0$. There are two possible cases here. In the first case the function x monotonically increases as $t \rightarrow +\infty$; this solution is either hyperbolic or parabolic. In the second case, x reaches its maximum $X^+(v, \tau)$ and then decreases to the value $x = 0$. We introduce the function

$$h^+(v, \tau) = \begin{cases} \frac{\dot{x}^2(+\infty)}{2} + \int_0^{\infty} Q_0(x) dx & \text{in the first case,} \\ \int_0^{X^+} Q_0(x) dx & \text{in the second case,} \end{cases}$$

where

$$Q_0 = \frac{1}{2\pi} \int_0^{2\pi} Q(x, t) dt.$$

The function $h^-(v, \tau)$ (when $t \rightarrow -\infty$) is defined in similar fashion. In the stationary case, $h^+(v) \equiv h^-(v)$. In the further analysis an important role is played by the constant

$$J = \int_0^\infty Q_0(x) dx,$$

which exists according to condition c). If Q is independent of time, then J is the total energy of the parabolic motion. One can show that the h^\pm are differentiable functions.

On the plane Σ with polar coordinates $v, \tau \bmod 2\pi$ we consider the two curves $\Pi^\pm = \{h^\pm = J\}$. These closed differentiable curves bound on Σ some domains R^\pm containing the point $v = 0$.

Proposition 7.3. *If the point (v, τ) lies outside (on) Π^\pm , then the function $x(t)$ is monotonic and the motion is hyperbolic (respectively, parabolic) as $t \rightarrow \pm\infty$. If the point (v, τ) lies inside R^+ (R^-), then $x(t)$ has at least one zero for $t > \tau$ (respectively, for $t < \tau$).*

◁ The inequality $h^+ \geq J$ is equivalent to the condition $X^\pm(v, \tau) = \infty$, which in turn implies the equality $h^+ - J = \dot{x}^2(+\infty)/2$. If $\dot{x}(+\infty) > 0$ (or $= 0$), then the motion is hyperbolic (respectively, parabolic). ▷

According to Proposition 7.3, for points (v, τ) in R^+ the natural map $S: (v, \tau) \mapsto (v', \tau')$ is defined, where τ' is the zero of the function $x(t)$ nearest to τ , and v' is the velocity of the point at the instant τ' (by the symmetry $x \rightarrow -x$ we can assume that $v' > 0$; see Fig. 7.7). Clearly, $SR^+ = R^-$ and $h^+ \circ S = h^-$.

Lemma 7.4. *The map $S: R^+ \rightarrow R^-$ preserves area on Σ .*

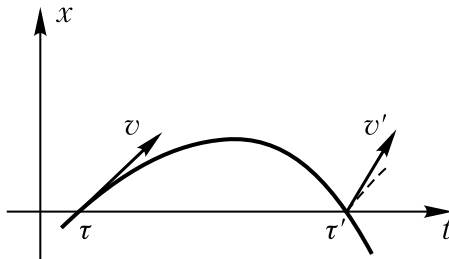

Fig. 7.7.

◁ Equation (7.22) is of course Hamiltonian with the Hamiltonian function

$$H(y, x, t) = \frac{y^2}{2} + U(x, t),$$

where $y = \dot{x}$. Let Γ be a closed contour in the domain R^+ and let $\Gamma' = S(\Gamma)$. By the integral invariant theorem we have

$$\oint_{\Gamma} y dx - H dt = \oint_{\Gamma'} y dx - H dt \Leftrightarrow \oint_{\Gamma} v^2 d\tau = \oint_{\Gamma'} v^2 d\tau. \quad \triangleright$$

From this assertion one can derive, in particular, the following.

Proposition 7.4. *Almost all solutions oscillating in the past are oscillating in the future, and vice versa.*

◁ Let A_m be the set of points $(v, \tau) \in \Sigma$ such that the solution $x(t)$ has infinitely many zeros for $t \geq \tau$, and exactly m zeros for $t < \tau$. It is clear that $S(A_m) = A_{m+1}$, $\text{meas}(A_m) = \text{meas}(A_{m+1})$ (Lemma 7.4), and $A_k \cap A_l = \emptyset$ for $k \neq l$. We are interested in the measure of the set $A = \bigcup_{m \geq 0} A_m$. If $\text{meas} A_m \neq 0$, then $\text{meas} A = \infty$. But the measure of A is finite, since this set is entirely contained in the disc of radius

$$2 \left(\pi \int_0^\infty \Psi(x) dx \right)^{1/2}.$$

Indeed, multiplying equation (7.24) by \dot{x} and integrating from τ to t we obtain

$$\frac{v^2}{2} - \frac{\dot{x}^2}{2} = - \int_t^\tau \dot{x} Q dt = \int_0^{x(t)} Q(x, t) dt.$$

It remains to use the inequality $Q < 2\pi\Psi(x)$ for $x > 0$, which follows from condition e). ▷

Since the domains R^+ and R^- have non-empty intersection and their measures are equal, the boundaries Π^+ and Π^- intersect in at least two points. We assume in what follows that Π^+ and Π^- intersect transversally. For example, in the case of equation (7.23) for zero value of the eccentricity we have $\Pi^+ = \Pi^- = \{v = \sqrt{2}\}$. By the symmetry of the problem with respect to the junction instant $\tau = 0$, in the general case the curves Π^+ and Π^- have common points on the ray $\tau = 0$. One can show that, at least for small values of $e > 0$, the curves Π^+ and Π^- intersect at these points transversally.

In a neighbourhood of an intersection point of Π^+ and Π^- , the functions $\xi = h^+ - J$ and $\eta = h^- - J$ can be chosen as local coordinates on Σ . Consider

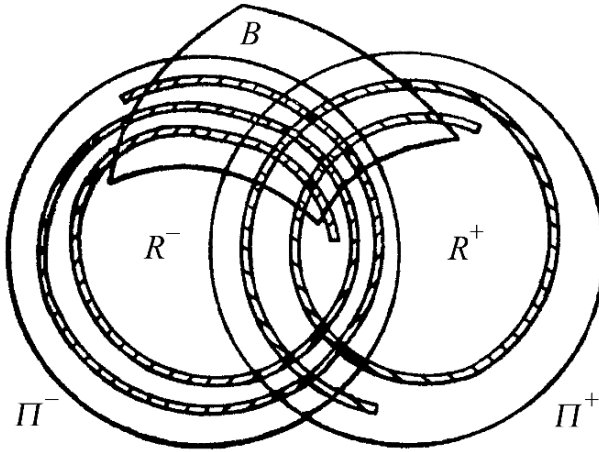

Fig. 7.8.

a small square $B = \{|\xi| \leq \varepsilon, |\eta| \leq \varepsilon\}$. One can show that for small values of ε the set $S(B \cap R^+)$ is a “spiral” winding round the curve Π^- , and the set $S^{-1}(B \cap R^-)$ is a similar spiral winding round Π^+ (see Fig. 7.8). This is a consequence of the hyperbolicity of the map S (S^{-1}) in a neighbourhood of the point $\xi = \eta = 0$: the map S is a compressing map along the η -axis, and stretching along the ξ -axis (see the details in [2]). The set $S(B \cap R^+) \cap B \cap R^+$ consists already of infinitely many connected components. Each of them is transformed by the map S into a narrow spiral contained inside the spiral $S(B \cap R^+)$. Iterating the map S both in the positive and in the negative direction we obtain more and more narrow strips in the square B transversally intersecting each other. In the limit we obtain a Cantor (perfect and nowhere dense) set $A \subset B$ that is invariant under all integer powers of the map S . Here, the orbit of any point $(v, \tau) \in A$ (that is, the set $S^n(v, \tau), n \in \mathbb{Z}$) has a very intricate form, characteristic of a random walk on the set A . The proof of these assertions can be found in the papers of Alekseev [2]. We illustrate what was said above by a certain model example.

7.3.2 Symbolic Dynamics

We consider the unit square $B = \{(x, y) \in \mathbb{R}^2: 0 \leq x, y \leq 1\}$ and define a map of the square B into itself by the formulae

$$\begin{aligned}
 \text{if } 0 \leq x \leq \frac{1}{3}, & \quad \text{then } x \mapsto 3x, & y \mapsto \frac{y}{3}, \\
 \text{if } \frac{2}{3} \leq x \leq 1, & \quad \text{then } x \mapsto 3x - 2, & y \mapsto \frac{y}{3} + \frac{2}{3}.
 \end{aligned} \tag{7.24}$$

The map S is undefined in the strip $1/3 < x < 2/3, 0 \leq y \leq 1$. The geometric meaning of the transformation $S: B \rightarrow B$ is clear from Fig. 7.9.

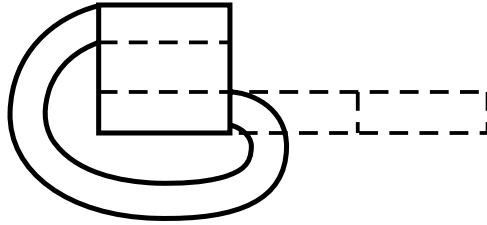

Fig. 7.9.

Let us determine the structure of the sets $S^n B \subset B$ for $n > 1$. To obtain SB we must remove from the square B the horizontal strip $[0, 1] \times (1/3, 2/3)$. Removing from the remaining two strips the more narrow strips $[0, 1] \times [1/9, 2/9]$ and $[0, 1] \times [7/9, 8/9]$ we obtain the set $S^2 B$, and so on (see Fig. 7.10). Continuing this process to infinity we arrive at the set $[0, 1] \times K_{[0,1]} \subset B$ (where $K_{[0,1]}$ is the Cantor set on the segment $[0, 1]$), on which all the negative powers of S are defined. Arguing in exactly the same way we obtain that all the positive powers of the map S are defined on the set $K_{[0,1]} \times [0, 1]$. Consequently, all the integer powers of S are defined on the direct product of Cantor sets $\Lambda = K_{[0,1]} \times K_{[0,1]}$.

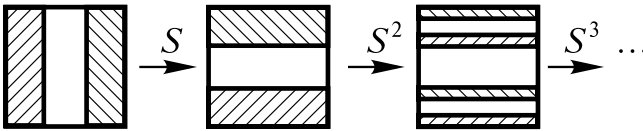

Fig. 7.10.

So what is the structure of the map $S: \Lambda \rightarrow \Lambda$? In order to answer this question we introduce the space Ω of sequences $\omega = \{\omega_n\}$ of zeros and ones where n runs over all integer values. We equip Ω with a topology \mathcal{T} by defining convergence as follows: a sequence $\omega^{(k)} \in \Omega$ converges to $\omega \in \Omega$ if $\omega_n^{(k)} \rightarrow \omega_n$ for every n .

Lemma 7.5. *The space (Ω, \mathcal{T}) is homeomorphic to Λ .*

◁ Indeed, we can associate with a sequence ω_n the two numbers

$$x = \frac{2 \sum_{s \geq 0} \omega_s}{3^{s+1}}, \quad y = \frac{2 \sum_{s \geq 0} \omega_{-s}}{3^s}, \tag{7.25}$$

which obviously belong to $K_{[0,1]}$. It is easy to realize that this correspondence is a homeomorphism. ▷

Let T be the map of Ω onto itself that takes $\omega = \{\omega_n\}$ to $\omega' = \{\omega_{n+1}\}$ (the shift of all indices by one).

Theorem 7.11. *There exists a homeomorphism $f: \Lambda \rightarrow \Omega$ such that the diagram*

$$\begin{array}{ccc} \Lambda & \xrightarrow{S} & \Lambda \\ f \downarrow & & \downarrow f \\ \Omega & \xrightarrow{T} & \Omega. \end{array}$$

is commutative.

The proof is based on a simple comparison of formulae (7.24) and (7.25).

Thus, with each trajectory $\{S^n(a)\}$, $a \in B$, $n \in \mathbb{Z}$, entirely contained in the square B we have associated a sequence of symbols $\omega = \{\omega_n\}$ so that to the action of the map S there corresponds the shift of all symbols by one to the left. This *method of coding trajectories*, which goes back to the papers of Birkhoff, Morse, Hedlund, is a basis of “*symbolic dynamics*”. One can learn about it in more detail in the works [2, 481].

Theorem 7.11 has a number of important consequences.

Proposition 7.5. *The map $S: \Lambda \rightarrow \Lambda$ has the following properties:*

- 1) *any two periodic trajectories can be connected by a doubly asymptotic trajectory,*
- 2) *the periodic points are dense in Λ ,*
- 3) *there exist trajectories that fill Λ everywhere densely.*

◁ Indeed, to a periodic trajectory there corresponds a point $(a) = (\dots a, a, a, \dots) \in \Omega$, where a is a finite block of zeros and ones. Suppose that points $(a), (b) \in \Omega$ correspond to two periodic trajectories. Then the sequence $(\dots, a, a, b, b, \dots)$ obviously corresponds to the required doubly asymptotic trajectory. Furthermore, with any element $\omega \in \Omega$ we can associate the sequence $\omega^{(n)} = (a_n) \in \Omega$, where $a_n = \{\omega_{-n}, \dots, \omega_n\}$. Clearly, $\omega^{(n)} \rightarrow \omega$. Finally, consider a point $\omega^* \in \Omega$ such that the sequence $\{\omega_n^*\}$, starting from some position, contains all finite blocks of zeros and ones written consecutively one after another. It is easy to see that the closure of the orbit $\bigcup_{n \in \mathbb{Z}} T^n \omega^*$ coincides with Ω . ▷

7.3.3 Absence of Analytic Integrals

Theorem 7.12. *Under the assumptions of § 7.3.1 differential equation (7.24) does not have a first integral that is analytic in \dot{x} , x , t and 2π -periodic in t .*

◁ If such an integral exists, then the map $S: R^+ \rightarrow R^-$ in § 7.3.1 has a non-constant analytic invariant function $f(v, \tau)$. One can show that the restriction of S to the invariant Cantor set Λ has the properties listed in Proposition 7.5 (see [2]). In particular, by continuity we have $f = \text{const}$ on the set Λ . It follows from the method of construction of the perfect set Λ that for every point $(v_0, \tau_0) \in \Omega$ there exist two sequences of points in Λ converging to

(v_0, τ_0) along two independent directions. Hence the derivatives of all orders with respect to v and τ at the point (v_0, τ_0) are equal to zero. To complete the proof it remains to use the analyticity of f . \triangleright

In conclusion we make several remarks.

1. Since Λ is nowhere dense, it is impossible to deduce from this argument that there are no smooth first integrals.

2. Symbolic dynamics for the restricted (and even unrestricted) three-body problem in § 7.3.1 was developed in the papers of Alekseev [2]. Using symbolic dynamics Alekseev has obtained all the logically possible combinations of types of final motion according to Chazy's classification.

3. In a neighbourhood of homoclinic periodic trajectories with transversal asymptotic surfaces, an assertion analogous to Theorem 7.11 holds, which goes back to Birkhoff (1935). A rigorous proof of this assertion is due to Smale (1965) and Shil'nikov (1967) (see [481]). Note that the proof of the absence of analytic integrals (Theorem 7.12) is independent of the transversality property. However, the presence of non-transversal asymptotic surfaces can have a strong effect on the qualitative behaviour of the trajectories (see [481]).

4. One can show that the periodic trajectories contained in Λ are hyperbolic and, consequently, non-degenerate. On the other hand, they are dense in Λ , and Λ is a key set in B . Hence the absence of analytic integrals can be established by Poincaré's method (see § 7.1.2).

7.4 Non-Integrability in a Neighbourhood of an Equilibrium Position (Siegel's Method)

Yet another method for proving non-integrability is based on lower estimates for the coefficients of the power series for formal integrals. Here divergence is caused by abnormally *small denominators*, that is, ultimately, by the influence of the resonances close to the equilibrium position under consideration.

We consider a canonical system of differential equations

$$\dot{x}_k = \frac{\partial H}{\partial y_k}, \quad \dot{y}_k = -\frac{\partial H}{\partial x_k} \quad (1 \leq k \leq n) \quad (7.26)$$

and suppose that H is an analytic function in a neighbourhood of the point $x = y = 0$ such that $H(0) = 0$ and $dH(0) = 0$. Let $H = \sum_{s \geq 2} H_s$, where H_s is a homogeneous polynomial of degree s in x and y .

Let $\lambda_1, \dots, \lambda_{2n}$ be the eigenvalues of the linearized canonical system with Hamiltonian H_2 . We can assume that $\lambda_{n+k} = -\lambda_k$ for $1 \leq k \leq n$. We consider the case where the numbers $\lambda_1, \dots, \lambda_n$ are purely imaginary and independent over the field of rational numbers.

In this section we study the complete integrability of equations (7.26) in a neighbourhood of the equilibrium position $x = y = 0$ and the convergence of the Birkhoff normalizing transformation.

We consider the set \mathcal{H} of all the power series

$$H = \sum h_{ks} x^k y^s, \quad k = (k_1, \dots, k_n), \quad s = (s_1, \dots, s_n),$$

converging in some neighbourhood of the point $x = y = 0$. We introduce in \mathcal{H} the following topology \mathcal{T} : a neighbourhood of a power series H^* with coefficients h_{ks}^* is defined to be the set of power series with coefficients h_{ks} satisfying the inequalities $|h_{ks} - h_{ks}^*| < \varepsilon_{ks}$, where ε_{ks} is a sequence of positive numbers. Choosing arbitrary sequences of positive numbers ε_{ks} we get various neighbourhoods of the point $H^* \in \mathcal{H}$.

Theorem 7.13. *In any neighbourhood of any point $H^* \in \mathcal{H}$ there exists a Hamiltonian H such that the corresponding canonical system (7.26) does not have an integral that is independent of the function H and is analytic in a neighbourhood of the equilibrium position $x = y = 0$.*

Thus, non-integrable systems are everywhere dense in \mathcal{H} . In particular, the Hamiltonian systems for which the Birkhoff transformation diverges are everywhere dense. The idea of the proof of the theorem is as follows. Let

$$F = \sum f_{ks} x^k y^s \tag{7.27}$$

be a formal integral of equations (7.26) independent of the function H . The existence of F follows from Birkhoff's theorem (§5.1.3). One can show that in any neighbourhood of a point $H^* \in \mathcal{H}$ there exists a Hamiltonian H to which there corresponds a formal series (7.27) such that infinitely many of its coefficients satisfy the estimate $|f_{ks}| \geq m^{m^2}$, where $m = |k| + |s|$. This is achieved by the choice of the eigenvalues $\lambda_1, \dots, \lambda_n$ that are sufficiently fast approximated by rational numbers. On the other hand, if equations (7.26) have an analytic integral independent of H , then the estimate $|f_{ks}| < cm^m$, $c = \text{const}$, holds. All the details of the proof can be found in [44].

As for divergence of the Birkhoff transformation we have the following stronger result.

Theorem 7.14 ([45]). *The Hamiltonian functions H for which the Birkhoff transformation converges form in \mathcal{H} a subset of the first Baire category² in the topology \mathcal{T} .*

More precisely, Siegel proved the existence of a denumerable set of analytically independent power series Φ_1, Φ_2, \dots in infinitely many variables h_{ks} which converge absolutely for $|h_{ks}| < \varepsilon$ (for all k, s) and are such that if a

² That is, it can be represented in the form of a countable union of nowhere dense sets.

point $H \in \mathcal{H}$ can be reduced to a normal form by a convergent Birkhoff transformation, then almost all the Φ_s vanish at this point (except for, possibly, finitely many of them). Since the functions Φ_s are analytic, their zeros are nowhere dense in \mathcal{H} . Consequently, the set of points in \mathcal{H} satisfying at least one equation $\Phi_s = 0$ is of the first Baire category. If we attempt to investigate the convergence of the Birkhoff transformation in some concrete Hamiltonian system, then we have to verify infinitely many conditions. No finite method is known for this purpose, although all the coefficients of the series Φ_s can be calculated explicitly. The proof of the theorem is based on a careful analysis of isolated long-periodic solutions in a neighbourhood of the equilibrium position. Thus, ideologically the proof also goes back to the earlier studies of Poincaré (see § 7.1.2).

Remark 7.5. Let us introduce in the set \mathcal{H} the new topology \mathcal{T}' in which a neighbourhood of the series with coefficients h_{ks}^* consists of all the converging power series with coefficients h_{ks} satisfying the inequalities $|h_{ks} - h_{ks}^*| < \varepsilon$ for $|k| + |s| \leq N$, for some $\varepsilon > 0$ and $N \geq 3$. One can show that with respect to the topology \mathcal{T}' the set of Hamiltonians with converging Birkhoff transformations is everywhere dense in \mathcal{H} . Indeed, if we discard the terms of order higher than N in the formal power series defining the Birkhoff transformation and then touch up the coefficients of the leading terms of the series of this Hamiltonian, then we obtain a converging canonical transformation reducing the Hamiltonian thus modified to a normal form. Note that the topology \mathcal{T}' is of course much weaker than the topology \mathcal{T} .

Using Siegel's method one can prove that the non-integrable systems are everywhere dense in certain subspaces of the space \mathcal{H} . As an example we consider the equation

$$\ddot{x} = -\frac{\partial U}{\partial x}, \quad x \in \mathbb{R}^n, \quad (7.28)$$

which describes the motion of a material point in a force field with potential $U(x)$. This equation can of course be written in the Hamiltonian form:

$$\dot{x} = H'_y, \quad \dot{y} = -H'_x; \quad H = \frac{y^2}{2} + U(x).$$

Let $U(0) = 0$ and $dU(0) = 0$. Then the point $x = 0$ is an equilibrium position. We set $U = \sum_{s \geq 2} U_s$, and let $U_2 = \sum \omega_k^2 x_k^2 / 2$. We assume that the frequencies of small oscillations $\omega_1, \dots, \omega_n$ are rationally independent.

We introduce the space \mathcal{U} of power series

$$\sum_{|k| \geq 2} u_k x^k$$

converging in some neighbourhood of the point $x = 0$. We equip \mathcal{U} with the topology \mathcal{T} defined above for the space \mathcal{H} .

Theorem 7.15. *The points for which equations (7.28) have no integral $F(\dot{x}, x)$ that is analytic in a neighbourhood of the point $\dot{x} = x = 0$ and is independent of the energy integral $E = \dot{x}^2/2 + U(x)$ are everywhere dense in the space \mathcal{U} with the topology \mathcal{T} .*

Apparently, the points $U \in \mathcal{U}$ for which the Birkhoff transformation converges form in \mathcal{U} a subset of the first Baire category. The proof of Theorem 7.15 is contained in [28].

In connection with the analysis of normal forms it is useful to bear in mind the following important circumstance: a divergent Birkhoff transformation may converge on some analytic invariant manifold Λ containing the equilibrium position. The dynamical system on Λ thus arising is integrable. A classical example of such a situation is provided by the following.

Theorem 7.16 (Lyapunov). *If the ratio λ_s/λ_1 is not an integer for all $s > 1$, then there exists an invertible analytic canonical transformation $(x, y) \mapsto (\xi, \eta)$ which reduces the Hamiltonian $H(x, y)$ to the form*

$$\Phi(\rho) + O(|\zeta|^2),$$

where Φ is a function of the single variable $\rho = \xi_1^2 + \eta_1^2$, and $\zeta = (\xi_2, \dots, \xi_n, \eta_2, \dots, \eta_n)$.

Thus, on the invariant manifold $\Lambda = \{\zeta = 0\}$ the Hamiltonian system (7.28) reduces to the system with one degree of freedom given by

$$\dot{\xi}_1 = 2\Phi'_\rho \eta_1, \quad \dot{\eta}_1 = -2\Phi'_\rho \xi_1.$$

Consequently, $\rho = \text{const}$ and $\xi_1 + i\eta_1 = c \exp(-2i\Phi'_\rho)t$. The phase plane \mathbb{R}^2 with coordinates ξ_1, η_1 is foliated into the invariant concentric circles $\xi_1^2 + \eta_1^2 = \rho$, on which the motion is uniform with frequency Φ'_ρ depending on ρ such that $\Phi'_\rho(0) = \lambda_1/2$.

A similar assertion is also valid in the case where among the eigenvalues λ_s there is a real pair $\lambda_1, -\lambda_1$. In this case, $\rho = \xi_1\eta_1$ (see the details in [46]).

Remark 7.6. As shown by Siegel, the condition $\lambda_s/\lambda_1 \notin \mathbb{Z}$ for $s > 1$ in Lyapunov's theorem cannot be dropped. Generalizations of this theorem to the case where this condition is not satisfied can be found in the papers of Roels [518, 519].

All that was said above, with necessary alterations, can be extended, for example, to the case of normal forms of Hamiltonian systems in a neighbourhood of periodic trajectories. A thorough analysis of convergence of normalizing transformations (and not only of Hamilton's equations) can be found in Bryuno's book [153].

7.5 Branching of Solutions and Absence of Single-Valued Integrals

In most of the integrated problems of Hamiltonian mechanics the known first integrals admit continuation to holomorphic or meromorphic functions in the complex domain of variation of the canonical variables. In this section we show that branching of solutions of Hamiltonian systems in the plane of complex time in the general case is an obstruction to the existence of new single-valued first integrals.

7.5.1 Branching of Solutions as Obstruction to Integrability

Let $D_{\mathbb{C},\delta} = \{I \in \mathbb{C}^n : \operatorname{Re} I \in D \subset \mathbb{R}^n, |\operatorname{Im} I| < \delta\}$, let $\mathbb{T}_{\mathbb{C}}^n = \mathbb{C}^n / 2\pi\mathbb{Z}^n$ be the complex torus (over \mathbb{R} this is $\mathbb{T}^n \times \mathbb{R}^n$) with complex-angle coordinates $\varphi_1, \dots, \varphi_n \pmod{2\pi}$, and let E be some neighbourhood of zero in \mathbb{C} . Let $H : D_{\mathbb{C},\delta} \times \mathbb{T}_{\mathbb{C}}^n \times E \rightarrow \mathbb{C}$ be a holomorphic function which takes real values for real values of I, φ, ε and is such that $H(I, \varphi, 0) = H(I)$.

The direct product $D_{\mathbb{C},\delta} \times \mathbb{T}_{\mathbb{C}}^n$ is equipped with the simplest symplectic structure, in which Hamilton's equations with Hamiltonian H have the canonical form

$$\frac{dI}{dt} = -\frac{\partial H}{\partial \varphi}, \quad \frac{d\varphi}{dt} = \frac{\partial H}{\partial I}; \quad H = H_0 + \varepsilon H_1 + \dots \quad (7.29)$$

All the solutions of the system with the Hamiltonian function H_0 are single-valued on the plane of complex time $t \in \mathbb{C}$:

$$I = I_0, \quad \varphi = \varphi^0 + \omega(I^0)t.$$

For $\varepsilon \neq 0$ the solutions of the ‘‘perturbed’’ equations (7.29), generally speaking, are no longer single-valued. Let γ be some closed contour on the plane of complex time. According to the well-known *Poincaré theorem* the solutions of equations (7.29) can be expanded in the power series

$$\begin{aligned} I &= I^0 + \varepsilon I^1(t) + \dots, & \varphi &= \varphi^0 + \omega t + \varepsilon \varphi^1(t) + \dots, \\ I^1(0) &= \dots = \varphi^1(0) = \dots = 0, \end{aligned} \quad (7.30)$$

converging for sufficiently small values of the parameter ε if $t \in \gamma$.

We say that an analytic vector-function $f(t), t \in \mathbb{C}$, is not single-valued along the contour γ if it undergoes a jump $\Delta f = \xi \neq 0$ after going around the contour γ . For example, if the function $I^1(t, I^0, \varphi^0)$ is not single-valued along γ , then for small values of the parameter ε the perturbed solution (7.30) is also non-single-valued along the contour γ . The jump ΔI^1 is obviously equal to

$$\xi = \int_{\gamma} \Phi(t) dt, \quad \text{where} \quad \Phi(t) = - \left. \frac{\partial H_1}{\partial \varphi} \right|_{I^0, \varphi^0 + \omega(I^0)t}.$$

If for fixed values of I the function H_1 is holomorphic in $\mathbb{T}_{\mathbb{C}}^n$, then, of course, $\xi = 0$. However, in practically important cases this function has singularities (say, poles). Therefore we assume the function to be holomorphic only in the domain $D_{\mathbb{C},\delta} \times \Omega \times E$, where Ω is a connected domain in $\mathbb{T}_{\mathbb{C}}^n$ containing the real torus $\mathbb{T}_{\mathbb{R}}^n$ and the closed contour Γ which is the image of the contour γ under the map $\varphi = \varphi^0 + \omega(I^0)t$, $t \in \gamma$.

We fix the initial data I^0, φ^0 and continuously deform the contour γ so that the contour Γ is not crossed by any singular point of the function H . Then, by Cauchy's theorem, after going around the deformed contour the function $I^1(t)$ will again change by the same quantity $\xi \neq 0$. On the other hand, since the solutions (7.30) are continuous with respect to the initial data, the function $I^1(t, I^0, \varphi^0)$ is not single-valued along the contour γ for all nearby values of I^0, φ^0 .

Theorem 7.17 ([324, 27]). *Suppose that the following conditions hold:*

- 1) $\det \left(\frac{\partial^2 H_0}{\partial I^2} \right) \neq 0$ in $D_{\mathbb{C},\delta}$,
- 2) for some initial data I^0, φ^0 the function I^1 is not single-valued along a closed contour $\gamma \subset \mathbb{C}\{t\}$.

Then equations (7.29) do not have a complete set of independent formal³ integrals

$$F_s = \sum_{i=0}^{\infty} F_i^s(I\varphi)\varepsilon^i \quad (1 \leq s \leq n)$$

whose coefficients are single-valued holomorphic functions in the direct product $V \times \Omega \subset D_{\mathbb{C},\delta} \times \mathbb{T}_{\mathbb{C}}^n$, where V is a neighbourhood of the point I^0 in $D_{\mathbb{C},\delta}$.

◁ We indicate the main points of the proof of the theorem. As always, first we show that the functions $F_0^s(I, \varphi)$ are independent of φ . Let $(I, \varphi) \in D \times \mathbb{T}_{\mathbb{R}}^n$ and let $F_0^s = \Phi_0^s + i\Psi_0^s$. Then Φ_0^s, Ψ_0^s are first integrals of the non-degenerate unperturbed system. By Lemma 7.1 they are independent of $\varphi \in \mathbb{T}_{\mathbb{R}}^n$. For $\varphi \in \Omega$ the constancy of the functions F_0^s follows from the connectedness of the domain Ω and from the uniqueness of an analytic continuation.

Then we prove that the functions $F_0^1(I), \dots, F_n^1(I)$ are dependent in the domain $V \subset D_{\mathbb{C},\delta}$. Indeed, since $F_s(I, \varphi, \varepsilon)$ is an integral of the canonical system (7.29), this function is constant on the solutions (7.30). Consequently, its values at time $t \in \gamma$ and after going around the contour γ coincide:

$$\begin{aligned} &F_0^s(I^0 + \varepsilon I^1(\tau) + \dots) + \varepsilon F_1^s(I^0 + \varepsilon I^1(\tau) + \dots, \varphi^0 + \omega\tau + \varepsilon\varphi_1(\tau) + \dots) + \dots \\ &\equiv F_0^s(I^0 + \varepsilon(I^1(\tau) + \xi(I^0)) + \dots) + \varepsilon F_1^s(I^0 + \dots, \varphi^0 + \omega\tau + \dots) + \dots \end{aligned}$$

³ We again consider a formal series $F = \sum F_i \varepsilon^i$ to be an integral of the canonical equations (7.29) if formally $\{H, F\} \equiv 0$. It is easy to see that in this case the composition of the power series (7.30) and $\sum F_i \varepsilon^i$ is a power series with constant coefficients.

Expanding this identity in power series in ε and equating the coefficients of the first power of ε we obtain

$$\left\langle \frac{\partial F_0^s}{\partial I}, \xi \right\rangle = 0, \quad 1 \leq s \leq n.$$

Since the jump ξ is non-zero in a neighbourhood of the point I^0 , the Jacobian identically vanishes, that is,

$$\frac{\partial(F_0^1, \dots, F_0^n)}{\partial(I_1, \dots, I_n)} \equiv 0,$$

in a whole domain V containing the point I^0 .

On the other hand, applying Poincaré’s method in § 7.1 we can prove the existence of independent integrals

$$\Phi_s(I, \varphi, \varepsilon) = \sum_{i \geq 0} \Phi_i^s(I, \varphi) \varepsilon^i$$

with coefficients holomorphic in the domain $W \times \Omega$ (where W is a small subdomain of V) such that the functions $\Phi_0^1, \dots, \Phi_0^n$ are independent. \triangleright

Example 7.1. We again consider the problem of the rapid rotation of a heavy asymmetric rigid body around a fixed point. The Hamiltonian function H in this problem is $H_0(I) + \varepsilon H_1(I, \varphi)$, $I \in \Delta \subset \mathbb{R}^2\{I\}$, $\varphi \in \mathbb{T}^2$ (see § 7.1.3). The perturbing function H_1 can be represented in the form of a sum

$$h_1(I, \varphi_1)e^{i\varphi_2} + h_2(I, \varphi_1)e^{-i\varphi_2} + h_3(I, \varphi_1),$$

such that for fixed values of $I \in \Delta$ the functions $h_s(I, z)$ ($1 \leq s \leq 3$) are elliptic (doubly periodic meromorphic functions of $z \in \mathbb{C}$). Hence the Hamiltonian H can be continued to a single-valued meromorphic function on $\mathbb{T}_{\mathbb{C}}^2$.

Let $\varphi^0 = 0$, and suppose that I^0 belongs to the Poincaré set of the perturbed problem. On the complex plane $t \in \mathbb{C}$ we consider the closed contour γ – the boundary of the rectangle $ABCD$ (see Fig. 7.11). Here T and iT'

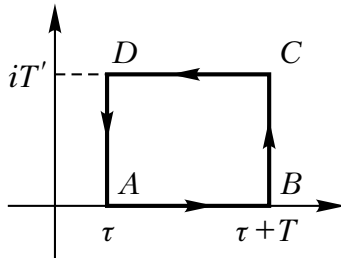

Fig. 7.11.

are, respectively, the real and purely imaginary periods of the elliptic functions $h_s(I^0, \omega_1 z)$, where $\omega_1 = \partial H_0 / \partial I_1$. The number τ is chosen so that these meromorphic functions have no poles on γ . One can show that the function $I_2^1(t, I^0, 0)$ is not single-valued along the contour γ ; see [324]. Consequently, the solutions of the perturbed problem branch in the plane of complex time, and this is an obstruction to the existence of a new single-valued integral.

Using the branching of solutions one can establish the non-existence of single-valued analytic integrals for small but fixed values of the parameter $\varepsilon \neq 0$ (see [626]). \triangle

7.5.2 Monodromy Groups of Hamiltonian Systems with Single-Valued Integrals

The existence of non-single-valued solutions can be established not only by using expansions in series in powers of the small parameter. For this purpose Lyapunov in 1894 proposed another method based on the analysis of variational equations for known single-valued solutions [400]. We already applied Lyapunov's method in the study of analytic singularities of multiple collisions in the many-body problem (see § 2.2.4). In this subsection we first consider linear Hamiltonian equations with holomorphic coefficients.

Let $H = \langle z, A(t)z \rangle / 2$ be a quadratic form in $z \in \mathbb{C}^{2n}$, where $A(t)$ is a given $2n \times 2n$ matrix whose elements are holomorphic functions defined on some Riemann surface X . For example, if the elements of the matrix $A(t)$ are meromorphic functions on \mathbb{C} , then X is the complex plane punctured at a certain number of points (poles). The linear Hamilton equations with Hamiltonian function H have the form

$$\dot{z} = I dH = IA(t)z. \quad (7.31)$$

For a given initial condition $z(t_0) = z_0$, there always exists locally a uniquely determined holomorphic solution. This solution can be continued along any curve in X , but in general this continuation is no longer a single-valued function on X . The branching of solutions of the linear system (7.31) is described by its monodromy group G : to each element σ of the fundamental group $\pi_1(X)$ there corresponds a $2n \times 2n$ matrix T_σ such that after going around a closed path in the homotopy class σ the value of the function $z(t)$ becomes equal to $T_\sigma z(t)$. If τ is another element of the group $\pi_1(X)$, then $T_{\tau\sigma} = T_\tau T_\sigma$. Thus the correspondence $\sigma \mapsto T_\sigma$ defines a group homomorphism $\pi_1(X) \rightarrow G$.

We are interested in the problem of the existence of holomorphic integrals $F: \mathbb{C}^{2n} \times X \rightarrow \mathbb{C}$ for equation (7.31). Since any integral $F(z, t)$ is constant on solutions of equations (7.31), for each $t_0 \in X$ the function $F(z, t_0)$ is invariant under the action of the monodromy group G . This property imposes severe restrictions on the form of first integrals: if the group G is sufficiently "rich", then the only invariant functions (integrals) are constants.

Since system (7.31) is Hamiltonian, the transformations in the monodromy group are symplectic. The problem of the integrals of groups of symplectic transformations was studied by Ziglin in [627]. We briefly expound his results.

By Proposition 7.1 the eigenvalues $\lambda_1, \dots, \lambda_{2n}$ of a symplectic transformation $g: \mathbb{C}^{2n} \rightarrow \mathbb{C}^{2n}$ fall into pairs $\lambda_1 = \lambda_{n+1}^{-1}, \dots, \lambda_n = \lambda_{2n}^{-1}$. We say that a transformation $g \in G$ is *non-resonant* if an equality $\lambda_1^{m_1} \cdots \lambda_n^{m_n} = 1$ with m_1, \dots, m_n integers implies that $m_s = 0$ for all s . For $n = 1$ this condition means that λ is not a root of 1. Let T be a matrix of a non-resonant symplectic map g . Since none of the eigenvalues of the matrix T is equal to 1, the equation $Tz = z$ has only the trivial solution $z = 0$.

It is convenient to pass to a *symplectic basis* for the non-resonant map g : if $z = (x, y)$, $x = (x_1, \dots, x_n)$, $y = (y_1, \dots, y_n)$ are the coordinates in this basis, then $g: (x, y) \mapsto (\lambda x, \lambda^{-1}y)$. In this basis the symplectic structure ω has the form $\sum dy_k \wedge dx_k$. It is clear that the map g preserves ω . A symplectic basis exists if the symplectic transformation g has no multiple eigenvalues (this assertion is proved, for example, in the book [46]).

Let $F(z) = \sum_{s \geq 1} F_s(z)$ be an integral of the map g . Then all the homogeneous forms F_s are integrals too. Let $F_s(x, y) = \sum_{k+l=s} f_{kl} x^k y^l$. Then, clearly,

$$\sum f_{kl} x^k y^l = \sum \lambda^{k-l} f_{kl} x^k y^l.$$

If g is non-resonant, then s is even and $f_{kl} = 0$ for $k \neq l$.

Theorem 7.18 ([627]). *Let $g \in G$ be a non-resonant transformation. If the Hamiltonian system under consideration has n independent holomorphic integrals $F: \mathbb{C}^{2n} \times X \rightarrow \mathbb{C}$, then any transformation $g' \in G$ has the same fixed point as g and takes eigendirections of g to eigendirections. If any $k \geq 2$ of the eigenvalues of the transformation g' do not form on the complex plane a regular polygon with centre at zero, then g' commutes with g .*

The last condition holds automatically if g' is also non-resonant.

We now prove Theorem 7.18 for the simple but important for applications case where $n = 1$. Suppose that the eigenvalues of the map g are not roots of unity, and let $(x, y) = z$ be a symplectic basis for g . The eigendirections of the map g are the two straight lines $x = 0$ and $y = 0$. It was shown above that any homogeneous integral of g has the form $c(xy)^s$, $s \in \mathbb{N}$. Let g' be another map in the group G . Since the function $(xy)^s$ is invariant under the action of g' , the set $xy = 0$ is invariant under the map g' . Since g' is a non-singular linear map, the point $x = y = 0$ is fixed, and the map g' either preserves the eigendirections of the map g , or transposes them. In the first case g' clearly commutes with g , and in the second case g' has the form

$$x \mapsto \alpha y, \quad y \mapsto \beta x.$$

Since the map g' is symplectic, its matrix

$$S = \begin{pmatrix} 0 & \alpha \\ \beta & 0 \end{pmatrix}$$

satisfies the condition

$$S^* I S = I, \quad I = \begin{pmatrix} 0 & -1 \\ 1 & 0 \end{pmatrix},$$

whence $\alpha\beta = -1$. But in this case the eigenvalues of the matrix S are equal to $\pm i$. The points $\pm i$ form precisely the exceptional regular polygon that is mentioned in the hypothesis of the theorem. Hence the result.

We now consider the case where the elements of the matrix $A(t)$ are single-valued doubly periodic meromorphic functions of time $t \in \mathbb{C}$ having only one pole inside the parallelogram of periods. We can assume that $A(t)$ is a meromorphic function on the complex torus X obtained from the complex plane \mathbb{C} as the quotient by the period lattice. We consider two symplectic maps g and g' over the periods of the matrix $A(t)$. More precisely, g and g' are transformations in the monodromy group which correspond to basis non-homologous closed paths on X . Suppose that their eigenvalues satisfy the conditions of Theorem 7.18. Then for equation (7.31) to have n independent analytic integrals it is necessary that g and g' commute. Consequently, to going around the singular point (to the element $gg'g^{-1}g'^{-1} \in G$) there corresponds the identity map of the space \mathbb{C}^{2n} .

Suppose that a nonlinear Hamiltonian system

$$\dot{z} = I dH, \quad z \in \mathbb{C}^{2n}, \tag{7.32}$$

has a particular solution $z_0(t)$ that is single-valued on its Riemann surface X . We set $u = z - z_0(t)$. Then equation (7.32) can be rewritten in the form

$$\dot{u} = IH''_{zz}(z_0(t))u + \dots \tag{7.33}$$

The linear non-autonomous equation

$$\dot{u} = IH''(t)u$$

is the variational equation along the solution $z_0(t)$. This equation is of course Hamiltonian with the Hamiltonian function

$$\frac{1}{2} \langle u, H''(t)u \rangle.$$

To the integral $H(z)$ of the autonomous system (7.32) there corresponds the linear integral

$$\langle H'(z_0(t)), u \rangle$$

of the variational equations. It can be used, for example, for reducing by one the number of degrees of freedom of system (7.33).

Suppose that the nonlinear equation (7.32) has several independent holomorphic integrals $F_s(z)$ ($1 \leq s \leq m$). Then equation (7.33) also has first integrals – the homogeneous forms of the expansions of the functions F_s in series in powers of u :

$$\langle F'_s(z_0(t)), u \rangle + \dots$$

These forms are holomorphic functions of u and t in the direct product $\mathbb{C}^{2n} \times X$. We have the following.

Lemma 7.6 ([627]). *If equation (7.32) has m independent integrals, then the variational equation (7.33) has m independent integrals that are polynomials in u .*

Thus, for a Hamiltonian system to be completely integrable in the complex domain it is necessary that the linear canonical system be integrable.

Following Lyapunov, Ziglin applied these results to the problem of rotation of a heavy rigid body around a fixed point. It turned out that an additional holomorphic (and even meromorphic) integral exists only in the three classical cases of Euler, Lagrange, and Kovalevskaya (which is due to what she discovered her case, by following Weierstrass' suggestion to study the absence of branching). If we fix the zero value for the area constant, then we must also add the Goryachev–Chaplygin case.

Using this method one can prove the non-integrability of the Hénon–Heiles Hamiltonian system (Example 5.2, § 5.1.3) not only in the complex, but also in the real domain. A similar result is valid for the homogeneous two-component model of the *Yang–Mills equations* described by the Hamiltonian system with Hamiltonian

$$H = \frac{1}{2}(p_1^2 + p_2^2) + q_1^2 q_2^2.$$

The more difficult question of the existence of an additional real analytic integral for an arbitrary mass distribution in a rigid body so far remains open.

Remark 7.7. Since recently there is a renewed interest in integration of differential equations of mechanics in terms of ϑ -functions (the so-called “algebraic integrability”). Finding necessary conditions for algebraic integrability follows the method of Kovalevskaya which she applied in 1888 in dynamics of a rigid body. One can learn about the current state of these problems in [57, 58, 216].

7.6 Topological and Geometrical Obstructions to Complete Integrability of Natural Systems

According to the results of variational calculus, any one-dimensional closed cycle on the configuration manifold can be realized as the trajectory of a periodic solution of a sufficiently high fixed energy. On the other hand, almost

all the periodic solutions of a completely integrable system with n degrees of freedom are situated on n -dimensional tori forming smooth families. Thus, a sufficiently complicated topological structure of the configuration manifold of a natural system is an obstruction to its complete integrability. This idea can be successfully realized in the case of two degrees of freedom.

7.6.1 Topology of Configuration Spaces of Integrable Systems

Let M be a connected compact orientable analytic surface which is the configuration space of a natural mechanical system with two degrees of freedom. The topological structure of such a surface is well known: this is a sphere with a certain number \varkappa of handles. The number \varkappa is a topological invariant called the genus of the surface.

The state space – the tangent bundle TM – has the natural structure of a four-dimensional analytic manifold. We assume that the Lagrangian $L = T + V$ is a real analytic function on TM . The total energy $H = T - V$ is of course constant on the trajectories of the equation of motion $[L] = 0$.

Theorem 7.19. *If the genus of M is greater than 1 (that is, M is not homeomorphic to the sphere S^2 or the torus \mathbb{T}^2), then the equation of motion does not have a first integral that is analytic on TM and independent of the energy integral.*

There are numerous well-known examples of integrable systems with configuration space S^2 or \mathbb{T}^2 . Theorem 7.19 is not valid in the infinitely differentiable case: for any smooth surface M there exists a “natural” Lagrangian L such that Lagrange’s equation $[L] = 0$ on TM has a smooth integral independent (more precisely, not everywhere dependent) of the function H (see [28]).

Theorem 7.19 is a consequence of a stronger assertion which establishes the non-integrability of the equation of motion for fixed sufficiently high values of the total energy. The precise formulation is as follows. For all $h > h^* = \max_M (-V)$ the level set $M_h = \{H = h\}$ of the total energy is a three-dimensional invariant analytic manifold, on which there naturally arises an analytic differential equation. We call this equation the reduced equation. The following theorem holds.

Theorem 7.20 ([28]). *If the genus of M is greater than 1, then for all $h > h^*$ the reduced equation on M_h does not have a first integral that is analytic on the entire level set M_h .*

Remark 7.8. Theorems 7.19 and 7.20 are also valid in the non-orientable case if in addition the projective plane RP^2 and the Klein bottle K are excluded. Indeed, the standard regular double covering $N \rightarrow M$, where N is an orientable surface, induces a natural system on N , which has an additional integral if the system on M has a new integral. It remains to observe that the genus of the surface N is greater than 1 if M is not homeomorphic to RP^2 or K .

Let k be the Gaussian curvature of the Maupertuis Riemannian metric $(ds)^2 = 2(h + V)T(dt)^2$ on M . According to the Gauss–Bonnet formula we have

$$\int_M k \, d\sigma = 2\pi\chi(M),$$

where $\chi(M)$ is the Euler characteristic of the compact surface M . If the genus of M is greater than 1, then $\chi(M) < 0$ and, consequently, the Gaussian curvature is negative on average. If the curvature is negative everywhere, then the dynamical system on M_h is an *Anosov system* and, in particular, it is ergodic on M_h (see [4]). These conclusions are also valid in the multidimensional case (only one must require that the curvature be negative in all two-dimensional directions). Here the differential equation on M_h does not have even a continuous integral, since almost every trajectory is everywhere dense in M_h . Of course, a curvature that is negative on the average is by far not always negative everywhere.

We indicate the main points in the proof of Theorem 7.20. According to the principle of least action, the trajectories on M with total energy h are geodesics of the Maupertuis Riemannian metric ds . We fix a point $x \in M$ and consider the tangent vectors $v \in T_x M$ satisfying the equality $H(v, x) = h$. Let $f: M_h \rightarrow \mathbb{R}$ be a first integral. We say that a vector v is critical if the value of f at the point (v, x) is critical. First we show that there are infinitely many different critical velocities. If this is not the case, then the circle $S_x = \{v \in T_x M: H(v, x) = h\}$ is partitioned into finitely many intervals Δ_i such that all $v \in \Delta_i$ are non-critical. By Theorem 5.3 to each vector $v \in \Delta_i$ there corresponds a unique torus \mathbb{T}_v^2 which carries the motion $z(t)$ with the initial data $z(0) = x, \dot{z}(0) = v$. The union $D_i = \bigcup_{v \in \Delta_i} \mathbb{T}_v^2$ is obviously

diffeomorphic to $\Delta_i \times \mathbb{T}^2$. Let $\pi: TM \rightarrow M$ be the natural projection; we set $X_i = \pi(D_i)$. We claim that the homology groups $H_1(X_i) \subset H_1(M)$ cover “almost the entire” group $H_1(M)$, excepting, possibly, elements in $H_1(M)$ that belong to some finite set of one-dimensional subgroups. This can be deduced from *Gajdukov’s theorem* [238]: for any non-trivial class of freely homotopic paths on M there exists a geodesic semitrajectory $\gamma(t)$ outgoing from the point x and asymptotically approaching some closed geodesic in this homotopy class. If the velocity $\dot{\gamma}(0)$ is not critical, then $\gamma(t)$ is closed. The exceptional one-dimensional subgroups in $H_1(M)$ mentioned above are generated precisely by the closed geodesics onto which the asymptotic semitrajectories distinct from them “wind themselves round”. Since the continuous map $D_i \rightarrow X_i$ induces a homomorphism of the homology groups $H_1(D_i) \rightarrow H_1(X_i)$, and $H_1(D_i) \simeq \mathbb{Z}^2$, the group $H_1(M)$ is covered by finitely many groups of rank at most two. It is well known that if \varkappa is the genus of M , then $H_1(M) \simeq \mathbb{Z}^{2\varkappa}$. Since $\varkappa > 1$, we arrive at a contradiction.

Thus, there are infinitely many different critical velocities. Since every analytic function on a compact analytic manifold has only finitely many critical

values, the integral $f(v, x)$ is constant on the circles S_x . Consequently, f is a function on M . Since M is connected and compact, any two of its points can be connected by a shortest geodesic; hence, $f \equiv \text{const}$.

Remark 7.9. For the case of free motion (where $V \equiv 0$) Kolokol'tsov found another proof of Theorem 7.19 based on introducing a complex-analytic structure in M [318]. Ideologically this proof goes back to Birkhoff ([14], Ch. II).

On the other hand, as shown by Katok [308], the topological entropy of a geodesic flow on a closed surface of genus $g > 1$ is always positive. Since for an analytic system with an additional analytic integral the topological entropy is equal to zero (Paternain [495]), we obtain one more path to the proof of Theorems 7.19 and 7.20.

7.6.2 Geometrical Obstructions to Integrability

Let N be a closed submanifold with boundary on an analytic surface (the surface is no longer assumed to be compact). We denote by N_h the set of all points on M_h which are taken by the map $\pi: TM \rightarrow M$ to points in N . We say that N is *geodesically convex* if a shortest geodesic of the Maupertuis metric on M connecting close points of the boundary ∂N is entirely contained in N .

Theorem 7.21. *If on an analytic surface M there exists a compact geodesically convex subdomain N with negative Euler characteristic, then the reduced system on M_h does not have an analytic first integral. Moreover, an analytic integral does not exist even in a neighbourhood of the set N_h .*

The proof of Theorem 7.21 follows the scheme of arguments indicated in §7.6.1. An insignificant difference is that instead of the homology group $H_1(M)$ one uses free homotopy classes of closed paths on M .

Theorem 7.21 was successfully applied by Bolotin for proving the non-integrability of the problem of the motion of a point in the gravitational field of n fixed centres for $n > 2$ (see [123]). Recall that to the values $n = 1$ and $n = 2$ there correspond the integrable cases of Kepler and Euler.

Theorem 7.21 has a number of interesting consequences concerning conditions for integrability of geodesic flows on the sphere and on the torus.

Corollary 7.4. *Suppose that on a two-dimensional analytic torus there is a closed geodesic homotopic to zero. Then the geodesic flow generated by the metric on this torus does not have non-constant analytic integrals.*

Of course, by far not every metric on a two-dimensional torus has closed geodesics homotopic to zero. However, in a number of cases their existence

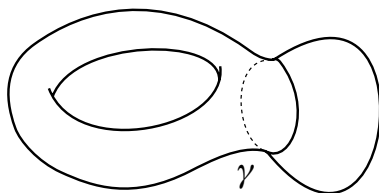

Fig. 7.12.

can be established using simple considerations of variational nature (see Fig. 7.12).

Now let M be homeomorphic to the two-dimensional sphere S^2 . By the Lyusternik–Shnirel'man theorem, on S^2 there always exist three closed non-self-intersecting geodesics $\gamma_1, \gamma_2, \gamma_3$. It turns out that integrability of the corresponding flow depends on their mutual disposition.

Corollary 7.5. *Suppose that the geodesics $\gamma_1, \gamma_2, \gamma_3$ do not intersect, and each of them can be deformed into a point without crossing the other two geodesics. Then the geodesic flow on S^2 does not admit a non-trivial analytic integral.*

◁ Indeed, in this case the γ_i divide S^2 into several geodesically convex domains, one of which has negative Euler characteristic (Fig. 7.13). ▷

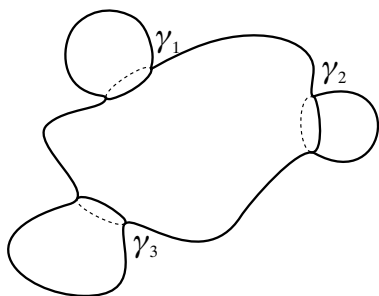

Fig. 7.13.

In [133] the variational methods were used to find geometric criteria for non-integrability of somewhat different type for analytic systems whose configuration space is a two-dimensional torus or a cylinder. These criteria were used to prove the non-integrability of the problem of oscillations of a double pendulum in a certain domain of variation of the parameters.

7.6.3 Multidimensional Case

A generalization of Theorem 7.19 to multidimensional reversible systems was obtained by Tajmanov [571, 572].

Theorem 7.22. *Suppose that the configuration space of a natural system with n degrees of freedom is a connected analytic manifold M^n , and the Hamiltonian function $H = T - V$ is an analytic function in the phase space. If this system has n independent analytic integrals, then the Betti numbers satisfy the inequalities*

$$b_k(M^n) \leq \binom{n}{k}. \quad (7.34)$$

If in addition $b_1(M^n) = n$, then in (7.34) inequalities become equalities.

For $k = 1$ inequality (7.34) yields

$$b_1 \leq n; \quad (7.35)$$

this inequality was mentioned in the first edition of this book as a conjecture. For a two-dimensional oriented surface we have $b_1 = 2g$, where g is the genus of the surface. In this case, (7.35) coincides with the inequality $g \leq 1$, and therefore Theorem 7.19 is a special case of Theorem 7.22.

In [571], topological obstructions to integrability were also found in terms of the fundamental group of the manifold M^n : there must be no commutative subgroups of finite index in this group.

These results relate to topological obstructions to complete integrability of systems with a “strongly multiply connected” configuration space. Obstructions to complete integrability of geodesic flows on *simply connected* manifolds were found by Paternain [495, 496]. Based on the well-known results of Dinaburg, Yomdin, and Gromov on the positivity of the topological entropy of geodesic flows on manifolds with exponential growth, as $\lambda \rightarrow \infty$, of the number of geodesics of length $\leq \lambda$ connecting pairs of generic points on M , Paternain showed that the configuration manifold M^n of a completely integrable flow is of *rationally elliptic type*. In particular, its Euler–Poincaré characteristic is non-negative. The main observation in the paper [495] itself is that the topological entropy of a completely integrable system with an analytic set of first integrals is equal to zero.

Certain geometrical obstructions to complete integrability of multidimensional reversible systems were found in [134].

7.6.4 Ergodic Properties of Dynamical Systems with Multivalued Hamiltonians

Apart from ordinary Hamiltonian systems, one can study “systems with multivalued Hamiltonians” in which, instead of a Hamiltonian function H on a symplectic manifold, a closed but not exact differential 1-form α is considered

(which plays the role of dH). A locally “Hamiltonian” vector field is defined by the form in the same way as it is defined by the form dH in an ordinary Hamiltonian system. But now there is no genuine first integral, because the “function” H is defined only locally and only up to a constant summand, and as it is continued along a closed path it acquired a finite (constant) increment (which, fortunately, does not affect the Hamiltonian vector field).

In the case of a two-dimensional multiply connected phase space (that is, for the surface of a torus, of a pretzel, or for a surface of a higher genus g , that is, a sphere with g handles), the question is about the “phase curves” defined by the equation “ $i_v\alpha = 0$ at each tangent vector v to the curve” (this condition is an analogue of the law of conservation of energy).

In order to understand the ergodic properties of such systems we consider the simplest case of a 1-form on a pretzel (a surface of genus 2) with two hyperbolic (saddle) singular points. A simplified model of this system can be described as follows. Consider an ordinary two-dimensional torus with a segment AB on it and two constant (invariant under the torus shifts) vector fields v_+ and v_- transversal to this segment. The phase space of the model is the two-sided surface of the torus with the cut along the segment AB , with the two sides of the torus glued together along this segment so as this is usually done for a two-sheet Riemann surface with branching of the second order at points A and B . On one side of the torus (on the “upper sheet”) the motion is along the field v_+ , and on the other side, along v_- . When a moving point reaches the segment of the cut, it passes to the other sheet and continues the motion there with different velocity.

In this model the phase flow preserves areas. We study this model using the method of “Poincaré section” (for the secant we can take, for example, the segment AB extended to a closed curve by a segment connecting B with A along one of the sides of the original torus). We consider successively the returns of the phase point to the secant.

Analysing the Poincaré map of the first return of a point of the secant circle ABA to itself we see that this map can be modelled by the following simple model. We divide an interval Δ of a straight line into consecutive intervals $\Delta_1, \Delta_2, \dots, \Delta_n$. We permute these intervals preserving their lengths in some other order, $\Delta_{i_1}, \Delta_{i_2}, \dots, \Delta_{i_n}$. We obtain a measure-preserving map of the interval Δ onto itself, which is called *interval exchange* (for $n = 2$ this is merely a rotation of the circle obtained from Δ by identification of the endpoints).

A slight complication of the interval exchange admits in addition turning over (changing the orientations) of some of the intervals. The question of the ergodic properties of all such interval exchanges was stated in 1963 in [7] as a model for studying slow mixing in Hamiltonian systems.

The studies of such systems that followed formed a whole theory, in which computer experiments gave rise to striking conjectures, and the technique of Teichmüller’s theory of moduli spaces of algebraic curves, to no less striking theorems (although much still remains unknown).

To explain what these amazing results are about, it is convenient to return to the original problem about a multivalued Hamiltonian and consider the “trajectories” $\alpha = 0$ for the closed 1-form α on the phase surface of genus g . The one-dimensional cohomology group of such a surface is \mathbb{R}^{2g} and it is generated by $2g$ basis closed 1-forms $\alpha_1, \dots, \alpha_{2g}$.

Integrating these forms along the phase curve $\alpha = 0$ we lift the curve to the (homology) space \mathbb{R}^{2g} , which is equipped with the integer homology lattice \mathbb{Z}^{2g} and the (symplectic integer-valued) form “intersection index”. Naturally, when we integrate along a long segment of the phase curve, we obtain a long segment in \mathbb{R}^{2g} , whose length is approximately proportional to the “time” t of the motion along the phase curve and whose direction is asymptotically determined by the “rotation numbers”, that is, by the cohomology class of the form α . In this sense, the phase curve is approximated by some straight line in \mathbb{R}^{2g} .

However, it turns out that the asymptotics of the deviation from this straight line can be described as follows. In \mathbb{R}^{2g} there is a hyperplane \mathbb{R}^{2g-1} from which the phase curve is asymptotically less distant than from other hyperplanes (at a distance of order t^{γ_1} as $t \rightarrow \infty$). Next, in \mathbb{R}^{2g-1} there is a hyperplane \mathbb{R}^{2g-2} the distance to which varies in wider limits, but less than for other planes of codimension 2. This deviation is of order t^{γ_2} as $t \rightarrow \infty$, and $\gamma_2 > \gamma_1$. And so on: we thus obtain a flag of planes of all dimensions from \mathbb{R}^{2g-1} to a Lagrangian plane \mathbb{R}^g and a set of exponents $\gamma_1 < \gamma_2 < \dots < \gamma_g$ of the deviation asymptotics.

Similar asymptotics can also be defined directly for interval exchange, but we do not do this here.

An unexpected discovery of Zorich, who carried out computer experiments with these multivalued Hamiltonian systems and with their models by interval exchange, is that the asymptotics indicated above not only exist (for almost all initial points), but are even stable: they are almost always independent either of the initial point, or the choice of the “Hamiltonian” α in a given homology class. In the case of interval exchange, analogous stable asymptotics prove to be independent of the lengths of the intervals of the partition (for almost all partitions in the sense of Lebesgue measure): these asymptotics are universal functions of the permutation i_1, \dots, i_n of the intervals (and in the case of changing orientation, of which of the intervals are turned over). These experimental discoveries provide one of the rare examples where computer experiments resulted in genuine mathematical results.

These amazing experimentally discovered universal ergodic properties were later proved by Zorich and Kontsevich, who also succeeded in obtaining certain number-theoretic information about the exponents $\gamma_1, \dots, \gamma_g$, on the rationality and algebraicity of their combinations, though unfortunately incomplete.

All these achievements are described in detail in the book [89] (especially, pp. IX–XII and 135–178). Incidentally, this book contains descriptions of many other applications of ergodic methods to the asymptotic theory of dynamical systems and their first integrals, of topological and geometrical almost periodic

and conditionally periodic structures and their averaged statistics, in the study of which, however, much also remains to be done. Here is a typical example (“stochastic web” of Zaslavskij). On Euclidean plane of vectors r consider five wave vectors V_k whose endpoints form a regular pentagon. Compose the sum of the five corresponding waves, $H = \sum \cos(r, V_k)$. The question is, are there arbitrarily large level lines of the function $H(r)$ separating zero from infinity?

Apart from the absence of first integrals, the chaotic nature of motion of complicated systems implies other properties, which may also be naturally called *non-integrability*. In this category there are, for example, the absence of invariant submanifolds (say, of dimension 2) or invariant ideals in the function algebra, the absence of invariant foliations (say, into two-dimensional surfaces), the absence of invariant differential forms (say, closed 1-forms, that is, “multivalued” integrals), the infinite-dimensionality of the linear spans of the unions of the vector spaces shifted by the phase flow (say, spaces of functions, forms, tensor fields, and so on). One can conjecture that many such strong “non-integrabilities” are typical (even, for example, for a typical Hamiltonian system with two degrees of freedom near an elliptic equilibrium position). The first steps in this direction are discussed in Chapter 9.

Theory of Small Oscillations

The study of the oscillations of a system in a neighbourhood of an equilibrium position or a periodic motion usually begins with linearization. The linearized system can be integrated. After this is done, the main properties of the oscillations in the original system can often be determined by using the theory of Poincaré–Birkhoff normal forms. This theory is an analogue of perturbation theory (§ 6.2). The linearized system plays the role of the unperturbed system with respect to the original one. In this chapter we describe the basic elements of this approach.

The central problem of theory of small oscillations is the study of stability of an equilibrium or a periodic motion. There is extensive literature devoted to stability theory (see the surveys [11, 12, 24]). We consider briefly only some results of this theory, which enable one to make conclusions on stability based on studying normal forms. We also describe results related to the problem of finding converses of Lagrange’s theorem on the stability of an equilibrium in a conservative field.

8.1 Linearization

We consider a natural Lagrangian system

$$\frac{d}{dt} \left(\frac{\partial L}{\partial \dot{q}} \right) - \frac{\partial L}{\partial q} = 0, \quad L = T - U(q), \quad T = \frac{1}{2}(A(q)\dot{q}, \dot{q}). \quad (8.1)$$

The equilibrium positions of system (8.1) are critical points of the potential energy U . In order to linearize system (8.1) about the equilibrium position $q = 0$ it is sufficient to replace the kinetic energy T by its value T_2 at $q = 0$, and the potential energy U by its quadratic part U_2 in a neighbourhood of zero.

Example 8.1. For a one-dimensional system,

$$L = a(q)\dot{q}^2/2 - U(q), \quad L_2 = T_2 - U_2 = \frac{1}{2}(a\dot{q}^2 - bq^2),$$

$$a = a(0), \quad b = \left. \frac{\partial^2 U}{\partial q^2} \right|_{q=0},$$

and the linearized equation of motion is $a\ddot{q} + bq = 0$. △

We now consider a Hamiltonian system. Its equilibrium positions are critical points of the Hamiltonian. In order to linearize a Hamiltonian system near an equilibrium position it is sufficient to replace the Hamiltonian by its quadratic part in a neighbourhood of this equilibrium position.

The linearization of a Hamiltonian system near a periodic trajectory is considered in § 8.3.2.

8.2 Normal Forms of Linear Oscillations

8.2.1 Normal Form of a Linear Natural Lagrangian System

We consider a dynamical system with a quadratic Lagrange function $L_2 = T_2 - U_2$, $T_2 \geq 0$. Its oscillations take a particularly simple form in special coordinates, which are called principal or normal.

Theorem 8.1. *A quadratic Lagrange function can be reduced by a linear change of coordinates $Q = Cq$ to a diagonal form*

$$L_2 = \frac{1}{2}(\dot{Q}_1^2 + \cdots + \dot{Q}_n^2) - \frac{1}{2}(\lambda_1 Q_1^2 + \cdots + \lambda_n Q_n^2), \quad (8.2)$$

and the equations of motion, correspondingly, to the form

$$\ddot{Q}_i = -\lambda_i Q_i, \quad i = 1, \dots, n. \quad (8.3)$$

The eigenvalues λ_i are the roots of the characteristic equation

$$\det(B - \lambda A) = 0,$$

where $T_2 = \frac{1}{2}(A\dot{q}, \dot{q})$ and $U_2 = \frac{1}{2}(Bq, q)$.

◁ The pair of quadratic forms T_2 and U_2 , one of which (T_2) is positive definite, can be reduced to principal axes by a simultaneous linear change of variables. The new coordinates can be chosen so that the form T_2 is reduced to the sum of squares. ▷

Corollary 8.1. *A system performing linear oscillations is a direct product of n linear one-dimensional systems.*

For each one-dimensional system (8.3) there are three possible cases:

- 1) $\lambda_i = \omega^2$; the solution is $Q = c_1 \cos \omega t + c_2 \sin \omega t$ (oscillations);
- 2) $\lambda_i = 0$; the solution is $Q = c_1 + c_2 t$ (neutral equilibrium);
- 3) $\lambda_i = -k^2 < 0$; the solution is $Q = c_1 \cosh kt + c_2 \sinh kt$ (instability).

Corollary 8.2. *Suppose that one of the eigenvalues is positive: $\lambda = \omega^2 > 0$. Then the system can perform a periodic oscillation of the form*

$$q(t) = (c_1 \cos \omega t + c_2 \sin \omega t)\xi,$$

where ξ is an eigenvector corresponding to λ : $B\xi = \lambda A\xi$.

This periodic motion is called a *characteristic oscillation* (or a *principal oscillation*, or a *normal mode*), and the number ω a *characteristic* (or *principal*, or *normal*) *frequency*.

These results are also valid when there are multiple eigenvalues: in contrast to a general system of differential equations (and even a general Hamiltonian system), in a natural Lagrangian system no resonant terms of the form $t \sin \omega t$, etc., can appear even in the case of multiple eigenvalues (only for $\lambda = 0$ Jordan blocks of order 2 appear).

8.2.2 Rayleigh–Fisher–Courant Theorems on the Behaviour of Characteristic Frequencies when Rigidity Increases or Constraints are Imposed

Of two linear Lagrangian systems with equal kinetic energies, the more rigid (or *stiff*) is by definition the one that has higher potential energy.

Theorem 8.2. *As the rigidity of a system performing small oscillations increases, all the characteristic frequencies increase.*

A natural Lagrangian system with $n - 1$ degrees of freedom is said to be obtained from a system with n degrees of freedom performing small oscillations by imposition of a linear constraint if its kinetic and potential energies are the restrictions of the kinetic and potential energies of the original system to an $(n - 1)$ -dimensional subspace.

Theorem 8.3. *The characteristic frequencies ω'_i , $i = 1, \dots, n - 1$ of the system with constraint separate the characteristic frequencies ω_i of the original system (Fig. 8.1).*

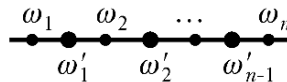

Fig. 8.1.

8.2.3 Normal Forms of Quadratic Hamiltonians

We consider a Hamiltonian system with a quadratic Hamiltonian function

$$\dot{z} = I \frac{\partial H}{\partial z}, \quad z \in \mathbb{R}^{2n}, \quad H = \frac{1}{2}(\Omega z, z), \quad I = \begin{pmatrix} 0 & -E_n \\ E_n & 0 \end{pmatrix}.$$

The roots of the characteristic equation

$$\det(I\Omega - \lambda E_{2n}) = 0$$

are called the eigenvalues of the Hamiltonian.

Theorem 8.4. *The eigenvalues of the Hamiltonian are situated on the plane of complex variable λ symmetrically with respect to the coordinate cross (Fig. 8.2): if λ is an eigenvalue, then $\bar{\lambda}$, $-\lambda$, $-\bar{\lambda}$ are also eigenvalues. The eigenvalues λ , $\bar{\lambda}$, $-\lambda$, $-\bar{\lambda}$ have equal multiplicities and the corresponding Jordan structures are the same.*

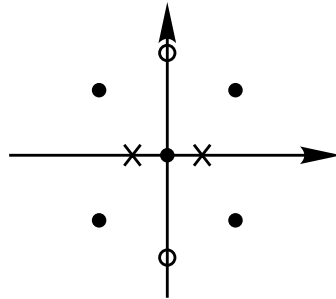

Fig. 8.2.

◁ The matrices $I\Omega$ and $(-I\Omega)^T$ are similar: $I\Omega = I^{-1}(-I\Omega)^T I$ (because $I^2 = -1$). ▷

Corollary 8.3. *In a Hamiltonian system stability is always neutral: if an equilibrium is stable, then the real parts of all the eigenvalues are equal to zero.*

Corollary 8.4. *If there is a purely imaginary simple eigenvalue, then it remains on the imaginary axis under a small perturbation of the Hamiltonian. Similarly, a real simple eigenvalue remains real under a small perturbation.*

Corollary 8.5. *If $\lambda = 0$ is an eigenvalue, then it necessarily has even multiplicity.*

According to Theorem 8.4, eigenvalues can be of four types: real pairs $(a, -a)$, purely imaginary pairs $(ib, -ib)$, quadruplets $(\pm a \pm ib)$, and zero eigenvalues.

For Hamiltonian systems the following assertion replaces the theorem on reduction of the matrix of a linear differential equation to the Jordan form.

Theorem 8.5 (Williamson [50]). *There exists a real symplectic linear change of variables reducing the Hamiltonian to a sum of partial Hamiltonians (functions of disjoint subsets of conjugate variables), and the matrix of the system, correspondingly, to a block-diagonal form. Each partial Hamiltonian corresponds either to a real pair, or to an imaginary pair, or to a quadruplet of eigenvalues, or to a zero eigenvalue. The partial Hamiltonians are determined, up to a sign, by the Jordan blocks of the operator $I\Omega$.*

The list of partial Hamiltonians is given in [10, 240].

All the eigenvalues of a generic Hamiltonian are simple. To a simple real pair $(a, -a)$ there corresponds the partial Hamiltonian $\mathcal{H} = -ap_1q_1$; to a simple purely imaginary pair $(ib, -ib)$, the Hamiltonian $\mathcal{H} = \pm b(p_1^2 + q_1^2)/2$ (the Hamiltonians with the upper and lower sign cannot be transformed into one another); to a quadruplet $(\pm a \pm ib)$, the Hamiltonian $\mathcal{H} = -a(p_1q_1 + p_2q_2) + b(p_1q_2 - p_2q_1)$. For an imaginary pair one often uses *symplectic polar coordinates* ρ, φ : $p = \sqrt{2\rho} \cos \varphi$, $q = \sqrt{2\rho} \sin \varphi$. Then the Hamiltonian is $\mathcal{H} = \pm b\rho$, where $\rho = (p^2 + q^2)/2$.

Corollary 8.6. *Let $\lambda = i\omega$ be a simple purely imaginary eigenvalue. Then the system can perform a periodic oscillation of the form*

$$z = \operatorname{Re} (\xi \exp (i\omega(t + t_0))),$$

where ξ is a corresponding eigenvector: $(I\Omega - i\omega E_{2n})\xi = 0$. This motion is called a *characteristic oscillation*, and ω a *characteristic frequency*.

Corollary 8.7. *If the eigenvalues are all distinct and purely imaginary, then the Hamiltonian can be reduced to the normal form*

$$H = \frac{1}{2}\omega_1(p_1^2 + q_1^2) + \dots + \frac{1}{2}\omega_n(p_n^2 + q_n^2) \tag{8.4}$$

or, in *symplectic polar coordinates*, $H = \omega_1\rho_1 + \dots + \omega_n\rho_n$. The motion is a sum of *characteristic oscillations*.

Remark 8.1. If the Hamiltonian has the form (8.4), then the equilibrium is stable regardless of whether the Hamiltonian is positive definite or not (for a natural Lagrangian linear system an equilibrium is stable only if the total energy is positive definite).

It is often necessary to consider not an individual Hamiltonian but a family depending on parameters. In such a family, for some values of the parameters there can appear singularities: multiple eigenvalues and, correspondingly,

Jordan blocks of order greater than 1 in the matrix of the system; moreover, these singularities can even be unremovable by a small change of the family of Hamiltonians. For every finite l , the unremovable singularities arising in l -parameter families of Hamiltonians are indicated in [240]. Also calculated therein are the versal deformations of these singularities, that is, normal forms to which any family of quadratic Hamiltonians smoothly depending on parameters can be reduced in a neighbourhood of singular values of the parameters by means of symplectic linear changes of variables smoothly depending on the parameters. In particular, in a one-parameter family of Hamiltonians, generally speaking, only the following three singularities occur: a real pair of multiplicity two, $(\pm a)^2$, with two Jordan blocks of order 2; an imaginary pair of multiplicity two, $(\pm ib)^2$, also with two Jordan blocks of order 2; and a zero eigenvalue of multiplicity two, $(0)^2$, with one Jordan block of order 2. The versal deformations of these singularities are:

$$\begin{aligned} (\pm a)^2: \quad \mathcal{H} &= -(a + \delta_2)(p_1q_1 + p_2q_2) + p_1q_2 + \delta_1p_2q_1, \\ (\pm ib)^2: \quad \mathcal{H} &= \pm \frac{p_1^2 + p_2^2}{2} + (b + \delta_2)(p_2q_1 - p_1q_2) + \frac{\delta_1(q_1^2 + q_2^2)}{2}, \\ (0)^2: \quad \mathcal{H} &= \pm \frac{p_1^2}{2} + \frac{\delta_1q_1^2}{2}. \end{aligned} \quad (8.5)$$

Here δ_1, δ_2 are the parameters of the deformations.

8.3 Normal Forms of Hamiltonian Systems near an Equilibrium Position

8.3.1 Reduction to Normal Form

Let the origin of coordinates be an equilibrium position of an analytic Hamiltonian system with n degrees of freedom. Suppose that the eigenvalues of the quadratic part of the Hamiltonian in a neighbourhood of the equilibrium position are all distinct and purely imaginary. In accordance with what was said in § 8.1 and § 8.2.2, we represent the Hamiltonian in the form

$$H = \frac{1}{2}\omega_1(p_1^2 + q_1^2) + \cdots + \frac{1}{2}\omega_n(p_n^2 + q_n^2) + H_3 + H_4 + \cdots, \quad (8.6)$$

where H_m is a form of degree m in the phase variables p, q . (Some of the frequencies ω_i can be negative.)

Definition 8.1. The characteristic frequencies $\omega_1, \dots, \omega_n$ satisfy a *resonance relation of order $l > 0$* if there exist integers k_i such that $k_1\omega_1 + \cdots + k_n\omega_n = 0$ and $|k_1| + \cdots + |k_n| = l$. For example, $\omega_1 = \omega_2$ is a relation of order 2.

Definition 8.2. A *Birkhoff normal form of degree L* for the Hamiltonian is a polynomial of degree L in symplectic phase variables P, Q that is actually a polynomial of degree $[L/2]$ in the variables $\rho_i = (P_i^2 + Q_i^2)/2$.

Example 8.2. For a system with two degrees of freedom,

$$H = \omega_1 \rho_1 + \omega_2 \rho_2 + \frac{1}{2} (\omega_{11} \rho_1^2 + 2\omega_{12} \rho_1 \rho_2 + \omega_{22} \rho_2^2) \quad (8.7)$$

is a Birkhoff normal form of degree 4. The terms quadratic in ρ describe the dependence of the frequencies of the oscillations on the amplitudes. \triangle

Theorem 8.6 (Birkhoff [14]). *Suppose that the characteristic frequencies ω_i do not satisfy any resonance relation of order L or less. Then in a neighbourhood of the equilibrium position 0 there exists a symplectic change of variables $(p, q) \mapsto (P, Q)$ fixing the equilibrium position 0 and such that in the new variables the Hamiltonian function is reduced to a Birkhoff normal form $\mathcal{H}_L(\rho)$ of degree L up to terms of degree higher than L :*

$$H(p, q) = \mathcal{H}_L(\rho) + R, \quad R = O(|P| + |Q|)^{L+1}. \quad (8.8)$$

Discarding the non-normalized terms R in (8.8) we obtain an integrable system whose action-angle variables are the symplectic polar coordinates ρ_i, φ_i defined by

$$P_i = \sqrt{2\rho_i} \cos \varphi_i, \quad Q_i = \sqrt{2\rho_i} \sin \varphi_i, \quad (8.9)$$

and whose trajectories wind round the tori $\rho = \text{const}$ with frequencies $\partial \mathcal{H}_L / \partial \rho$. Most of similar tori, which are invariant under the phase flow, in the general case exist also in the original system; this follows from the results of KAM theory (§ 6.3.6.B).

Birkhoff's normalization amounts to Lindstedt's procedure for eliminating the fast phases (§ 6.2.2) if we normalize the deviations from the equilibrium position by a small quantity ε (putting $p = \varepsilon \hat{p}$, $q = \varepsilon \hat{q}$, $\hat{H} = H/\varepsilon^2$) and pass to the symplectic polar coordinates.

The normalization procedure is described below for a more general case (see the proof of Theorem 8.7). The generating function of the normalizing transformation is constructed in the form of a polynomial of degree L in the phase variables. A change in the terms of degree l in the original Hamiltonian does not change the terms of degree lower than l in the normal form (and of degree lower than $l - 1$ in the normalizing transformation).

In the absence of resonances, a Hamiltonian is in normal form if and only if the Poisson bracket of the Hamiltonian and its quadratic part is identically zero (see Proposition 5.1).

Considering the normalization as $L \rightarrow \infty$ we arrive at the notion of formal normal form, which was discussed in § 5.1.3.

The definition of a normal form must be modified for the case where the characteristic frequencies satisfy some resonance relations. The same modification is also appropriate for nearly resonant frequencies. Let K be a sublattice of the integer lattice \mathbb{Z}^n defining the possible resonances (cf. § 6.1.1).

Definition 8.3. A resonant normal form of degree L for the Hamiltonian for resonances in K is a polynomial of degree L in symplectic variables P_i, Q_i which in the polar coordinates (8.9) depends on the phases φ_i only via their combinations (k, φ) for $k \in K$.

Theorem 8.7 ([179, 271]). Suppose that the characteristic frequencies do not satisfy any resonance relations of degree L or less, except, possibly, for relations $(k, \omega) = 0$ with $k \in K$. Then in a neighbourhood of the zero equilibrium position there exists a symplectic change of variables $(p, q) \mapsto (P, Q)$ fixing the zero equilibrium position and such that in the new variables the Hamiltonian function reduces to a resonant normal form of degree L for resonances in K up to terms of degree higher than L .

◁ In the system with Hamiltonian (8.6) we perform the change of variables with a generating function $Pq + S(P, q)$, $S = S_3 + \dots + S_L$. The new Hamiltonian has the form

$$\mathcal{H} = \frac{1}{2}\omega_1(P_1^2 + Q_1^2) + \dots + \frac{1}{2}\omega_n(P_n^2 + Q_n^2) + \mathcal{H}_3 + \mathcal{H}_4 + \dots,$$

where S_l and \mathcal{H}_l are forms of degree l in P, q and in P, Q , respectively. The old and new Hamiltonians are connected by the relation

$$H\left(P + \frac{\partial S}{\partial q}, q\right) = \mathcal{H}\left(P, q + \frac{\partial S}{\partial P}\right).$$

Equating here the forms of the same order in P, q we obtain

$$\sum_{j=1}^n \omega_j \left(P_j \frac{\partial S_l}{\partial q_j} - q_j \frac{\partial S_l}{\partial P_j} \right) = \mathcal{H}_l - F_l, \quad l = 3, \dots, L.$$

The form F_l is uniquely determined if we know the S_ν, \mathcal{H}_ν for $\nu \leq l - 1$. In the symplectic polar coordinates ρ, φ the last equation takes the form

$$\omega \frac{\partial S_l}{\partial \varphi} = \mathcal{H}_l - F_l.$$

We choose

$$S_l = \sum i \frac{f_k(\rho)}{(k, \omega)} \exp(i(k, \varphi)), \quad k \notin K,$$

where the f_k are the coefficients of the Fourier series of F_l . Then \mathcal{H}_l is in the required normal form. Thus we can successively determine all the S_l, \mathcal{H}_l . Returning to Cartesian coordinates we obtain the result. ▷

Suppose that the Hamiltonian is in a resonant normal form. If the rank of the sublattice $K \subset \mathbb{Z}^n$ defining the possible resonances is equal to r , then the system has $n - r$ independent integrals in involution which are linear combinations with integer coefficients of the quantities $\rho_i = (P_i^2 + Q_i^2)/2$

(cf. Theorem 6.15 in Ch. 6). In particular, if $r = 1$, then the system in the normal form is integrable.

Resonance normalization amounts to von Zeipel's procedure for eliminating the fast non-resonant phases (§ 6.2.2) if we normalize the deviations from the equilibrium position by a small quantity ε and pass to the symplectic polar coordinates.

In the presence of resonances, a Hamiltonian is in resonant normal form if and only if the Poisson bracket of the Hamiltonian and its quadratic part is identically zero (see Proposition 5.1).

If the matrix of the linearized system is not diagonalizable, then the quadratic part of the Hamiltonian cannot be reduced to the form (8.4). However, the nonlinear terms can be reduced to the form indicated in Theorem 8.7; see [151].

8.3.2 Phase Portraits of Systems with Two Degrees of Freedom in a Neighbourhood of an Equilibrium Position at a Resonance

Any system with two degrees of freedom whose Hamiltonian is in resonant normal form is integrable. One can reduce such a system to a system with one degree of freedom depending on the constant value of the first integral as a parameter, and then draw the phase portraits. If the coefficients of the lower terms of the normal form are generic, then for the given resonance there are only finitely many types of phase portraits, and these types are determined by the lower terms of the normal form. The phase portraits are qualitatively different only for finitely many resonances. Description of the portraits provides exhaustive information about the motion near the resonance for systems in a normal form in the generic case. Correspondingly, we obtain considerable information on the motion for systems in which the lower terms of the Hamiltonian can be reduced to this normal form. Below we give the list of phase portraits and their bifurcations. For lack of space we confine ourselves to the case where the frequencies ω_1 and ω_2 have different signs, since this case is more interesting from the viewpoint of stability theory (if $\omega_1\omega_2 > 0$, then an energy level $H = h \ll 1$ is a sphere, and the equilibrium is stable). The information requisite for constructing these portraits is contained in a series of papers of Alfriend, Henrard, van der Burgh, Duistermaat, Markeev, Roels, Sanders, Schmidt, et al. The complete information is presented in [217]. The portraits for resonances of order higher than 4 can be found in [534].

Let k_1, k_2 be coprime positive coefficients of a resonance relation. There exist coprime integers l_1, l_2 such that $k_1l_2 - k_2l_1 = 1$. In a neighbourhood of the equilibrium position we pass to the canonical polar coordinates ρ, φ given by (8.9) and then perform the change of variables

$$(\rho_1, \rho_2, \varphi_1, \varphi_2) \mapsto (G, I, \psi, \chi)$$

with the generating function

$$S = (k_1\varphi_1 + k_2\varphi_2) G + (l_1\varphi_1 + l_2\varphi_2) I,$$

so that

$$\begin{aligned} \psi &= k_1\varphi_1 + k_2\varphi_2, & G &= l_2\rho_1 - l_1\rho_2, \\ \chi &= l_1\varphi_1 + l_2\varphi_2, & I &= -k_2\rho_1 + k_1\rho_2. \end{aligned}$$

Since by the assumption the Hamiltonian is in a normal form, it is independent of χ ; correspondingly, I is an integral of the problem. We perform the isoenergetic reduction on an energy level $H = h$ (see [10]); as the new time we introduce the phase χ . We obtain the reduced system with one degree of freedom whose Hamiltonian depends on the parameter h . It is the phase portrait of this system that must be analysed. In the generic case the portrait depends essentially on one more parameter – the resonance detuning $\delta = k_1\omega_1 + k_2\omega_2$.

A neighbourhood of the origin on the plane h, δ is partitioned into the domains corresponding to different types of the phase portrait. These partitions for different resonances are shown in Fig. 8.3a–8.8a, and the bifurcations of the phase portrait for going around the origin clockwise are shown in Fig. 8.3b–8.8b, respectively. The numbering of the portraits corresponds to the numbering of the domains on the plane of parameters. The unnumbered portraits correspond to the curves separating the domains; they are given only in Fig. 8.3–8.5.

The normal forms for which the bifurcations are given have the form

$$H_{k_1, k_2} = \omega_1\rho_1 + \omega_2\rho_2 + F(\rho_1, \rho_2) + B\rho_1^{k_1/2}\rho_2^{k_2/2} \cos(k_1\varphi_1 + k_2\varphi_2 + \psi_0).$$

Here F is a polynomial in ρ_1, ρ_2 beginning with the quadratic form $F_2(\rho_1, \rho_2)$ (in the Hamiltonian $H_{2,1}$ the term F must be omitted), and B, ψ_0 are constants. The required genericity conditions are $B \neq 0, A = F_2(k_1, k_2) \neq 0$, and, for the Hamiltonian $H_{3,1}$, $|A| \neq 3\sqrt{3}|B|$. The pictures correspond to the case $\omega_1 > 0, A > 0, B > 0$ (this does not cause a loss of generality). The pictures are given for the following resonant vectors (k_1, k_2) : (2,1) in Fig. 8.3; (3,1) in Fig. 8.4 if $A < 3\sqrt{3}B$, and in Fig. 8.5 if $A > 3\sqrt{3}B$; (4,1) in Fig. 8.6; (3,2) in Fig. 8.7; and (4,3) in Fig. 8.8. For the resonant vectors $(n, 1), n \geq 5$, the bifurcations are the same as for (4,1); for $(n, 2), n \geq 5$, the same as for (3,2) but the domain (5) is skipped in Fig. 8.7; for $(n, 3), n \geq 5$, the same as for (4,3); and for $(n, m), n \geq 5, m \geq 4$, the same as for (4,3) but the domain (2) is skipped in Fig. 8.8. (Of course, the number of singular points of each type must be changed taking into account the symmetry of the Hamiltonian). The axis $\delta = 0$ is not a bifurcation line. The positions of the bifurcation lines with respect to this axis may be different from those shown in the pictures.

We make several further remarks on the presentation of the information. To ensure that the phase portraits have no singularities, we depicted them for $h > 0$ in the polar coordinates $\sqrt{\rho_2}, \psi/k_2$, and for $h < 0$ in the polar coordinates $\sqrt{\rho_1}, \psi/k_1$. For $h = 0$ the phase portrait in Fig. 8.3–8.5 is depicted

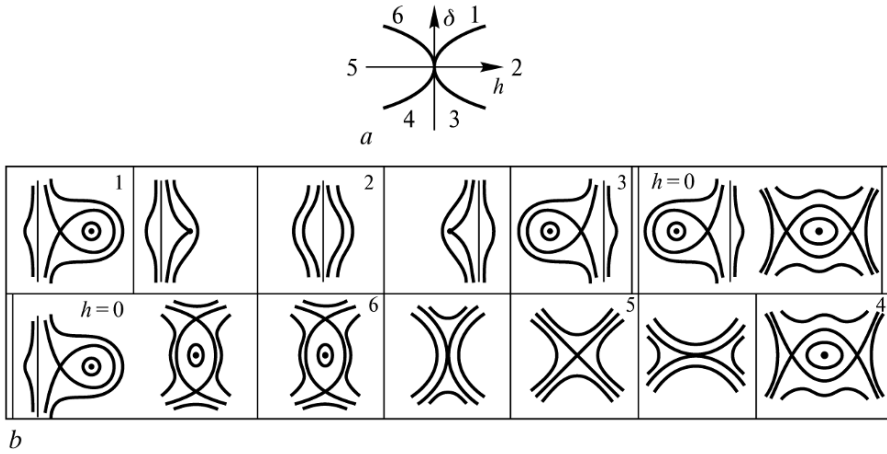

Fig. 8.3.

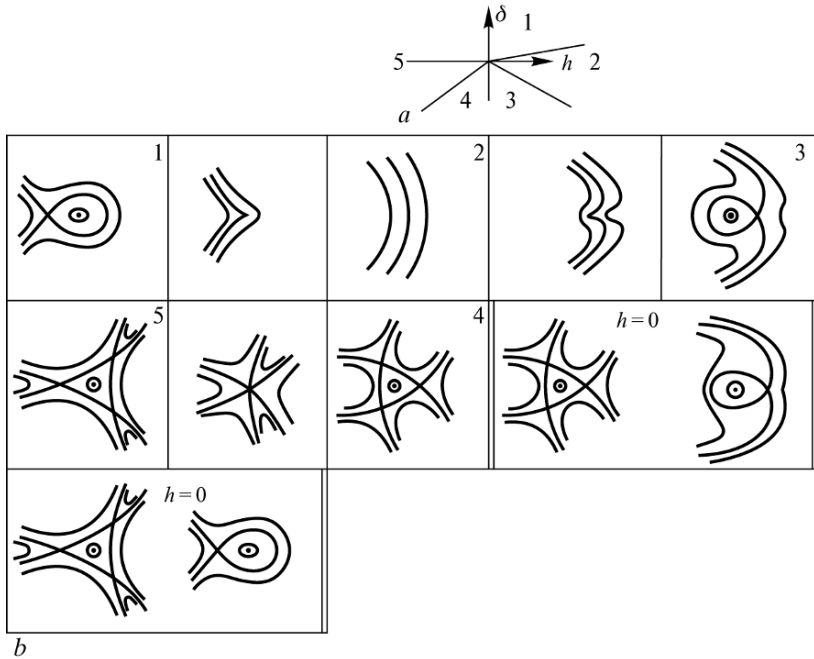

Fig. 8.4.

in both sets of coordinates. For $h > 0$ ($h < 0$) the portrait may be thought of as the section of a three-dimensional energy-level manifold by the plane $\varphi_1 = 0$ (respectively, $\varphi_2 = 0$). To the equilibrium positions on the phase

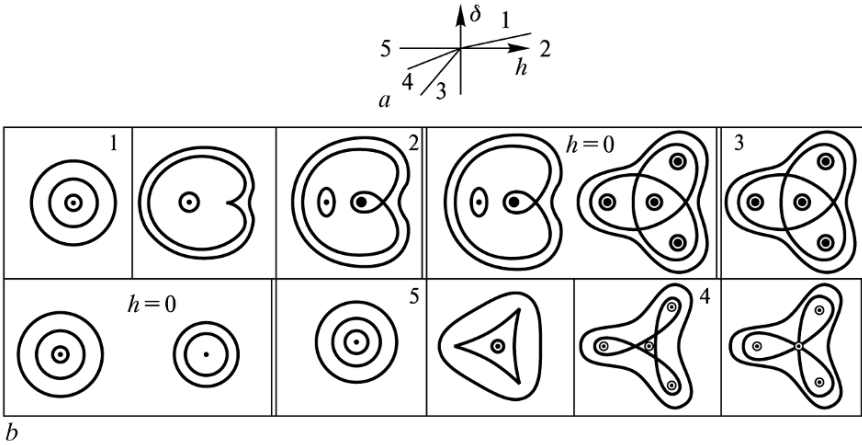

Fig. 8.5.

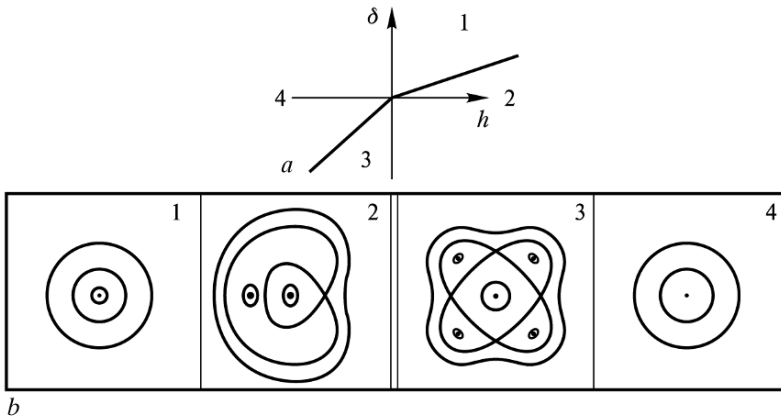

Fig. 8.6.

portrait there correspond periodic solutions¹ of the original system with two degrees of freedom, and to the closed curves there correspond two-dimensional invariant tori. Here to equilibrium positions obtained from one another by a rotation by angle $2\pi/k_2$ in the domain $h > 0$, or $2\pi/k_1$ in the domain $h < 0$, there corresponds one and the same periodic solution piercing the surface of the section k_2 times (respectively, k_1 times). Exactly the same is true for the two-dimensional tori.

To complete the analysis of resonances in systems with two degrees of freedom it remains to consider the resonances that are essential already in the

¹ For $h = 0$ to the equilibrium position at the centre of the portrait there corresponds an equilibrium of the original system.

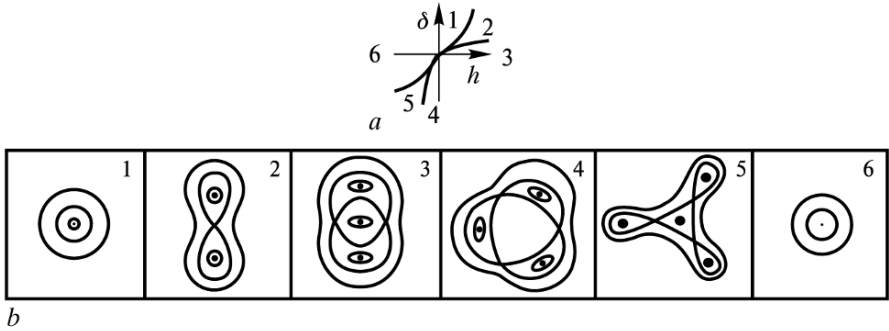

Fig. 8.7.

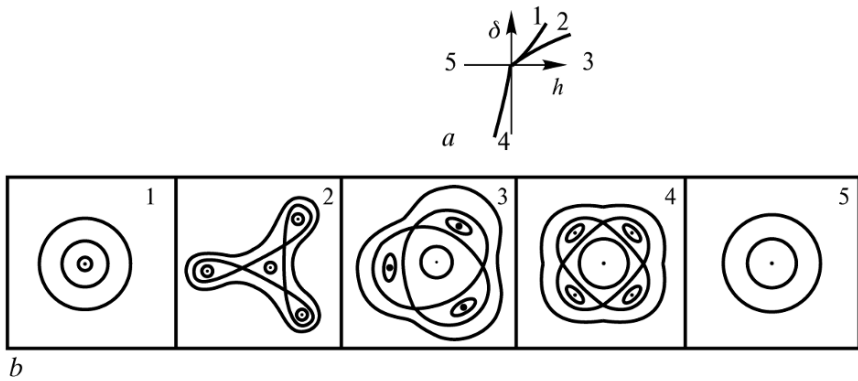

Fig. 8.8.

quadratic terms of the Hamiltonian: the case of multiple eigenvalues and the case of a zero eigenvalue.

For multiple eigenvalues, in the typical case the matrix of a linear Hamiltonian system has two Jordan blocks of order 2 (see § 8.2.3). If there are nearly multiple eigenvalues, then the quadratic part of the Hamiltonian can be reduced to the form $(\pm ib)^2$ in (8.5). According to [561], in this case the terms of the Hamiltonian of order up to and including 4 can be reduced to the following form, which is also called a normal form:

$$\begin{aligned}
 H = & \frac{a(p_1^2 + p_2^2)}{2} + \omega(p_2q_1 - p_1q_2) + \frac{\delta(q_1^2 + q_2^2)}{2} + \\
 & + (q_1^2 + q_2^2) [D(q_1^2 + q_2^2) + B(p_2q_1 - p_1q_2) + C(p_1^2 + p_2^2)], \quad (8.10)
 \end{aligned}$$

$$a = \pm 1.$$

The formal normal form is a series in $q_1^2 + q_2^2$, $p_1^2 + p_2^2$, and $p_2q_1 - p_1q_2$. Following [320, 563] we pass to the polar coordinates r, χ on the plane q_1, q_2 and introduce the corresponding momenta P, I defined by

$$\begin{aligned} q_1 &= r \cos \chi, & p_1 &= P \cos \chi - I \sin \frac{\chi}{r}, \\ q_2 &= r \sin \chi, & p_2 &= P \sin \chi + I \cos \frac{\chi}{r}. \end{aligned} \tag{8.11}$$

In the new variables the Hamiltonian (8.10) takes the form

$$H = \frac{1}{2}a \left(P^2 + \frac{I^2}{r^2} \right) + \omega I + r^2 \left(\frac{\delta}{2} + Dr^2 + BI + C \left(P^2 + \frac{I^2}{r^2} \right) \right). \tag{8.12}$$

Since the Hamiltonian is independent of the angle χ , the momentum I is an integral, and for P, r we obtain a system with one degree of freedom depending on the two parameters I and δ . Since we consider a neighbourhood of the equilibrium position $p = q = 0$, we can neglect the term $Cr^2(P^2 + I^2/r^2)$ in (8.12): this term is much smaller than the term in the first bracket in (8.12). The bifurcation diagram of the resulting system is given in Fig. 8.9 for the case $a = 1$ and $D > 0$, and in Fig. 8.10 for the case $a = 1$ and $D < 0$. It is assumed that $I \geq 0$, which does not cause any loss of generality.

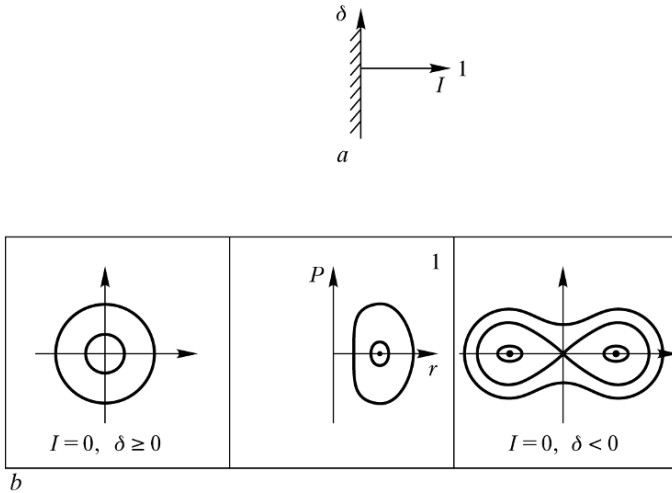

Fig. 8.9.

The left- and right-most phase portraits in Fig. 8.9, 8.10 correspond to $I = 0$. To ensure that they have no singularities we have to assume that r takes values of both signs. The curves on the portraits which are symmetric with respect to the axis $r = 0$ correspond to the same invariant surfaces in the phase space of the system with two degrees of freedom.

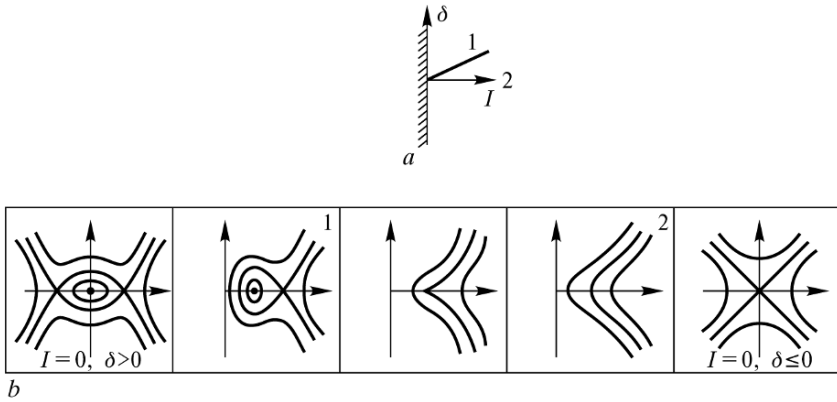

Fig. 8.10.

Finally, we consider the case of a zero eigenvalue (a degenerate equilibrium). This case appears already in systems with one degree of freedom; it is such a system that we shall consider.² We assume that in the linearized system to the zero eigenvalue there corresponds a Jordan block of order 2 (see § 8.2.3). If the equilibrium is nearly degenerate, then it cannot be shifted to the origin by a change of variables that is smooth in the parameters of the problem. Hence the linear part remains in the Hamiltonian. The terms of the Hamiltonian of order up to and including 3 can be reduced to the form

$$H = \delta q + \frac{ap^2}{2} + bq^3, \quad a = \pm 1. \tag{8.13}$$

Suppose that $a = 1$ and $b > 0$. The bifurcation of the phase portrait in the transition from negative δ to positive is shown in Fig. 8.11. The two equilibrium positions merge and disappear.

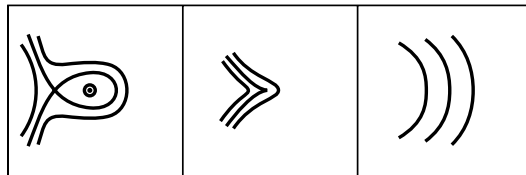

Fig. 8.11.

The diagrams given here exhaust all the resonance-related bifurcations that occur in one-parameter families of generic Hamiltonians with two degrees of freedom and can be calculated from the normal form.

² For two degrees of freedom, the order can be reduced to one by using the integral corresponding to the non-zero characteristic frequency.

These diagrams are also useful for a higher number of degrees of freedom. Indeed, suppose that in a system with n degrees of freedom there is a single resonance relation approximately satisfied by two frequencies. Then its normal form has $n - 2$ integrals $\rho_i = \text{const}$ and is reducible to a system with two degrees of freedom. As a result we obtain one of the normal forms considered above, whose coefficients depend on the parameters $\rho_i \ll 1$.

The study of multiple resonances in systems with many degrees of freedom is presently in its early stage. In [53] the case with frequency ratio $1 : 2 : 1$ was studied, its periodic solutions and additional integrals appearing for special values of the parameters were found. In [54] it was shown that for the resonance $1 : 2 : 2$ the normal form of order 3 has an additional symmetry, and the corresponding system is completely integrable. In [218] it was shown that for the resonance $1 : 1 : 2$ the normal form of order 3 generates a non-integrable system.³

8.3.3 Stability of Equilibria of Hamiltonian Systems with Two Degrees of Freedom at Resonances

Studying the normal form provides considerable information about the motion of the original system for which the lower terms of the Hamiltonian can be reduced to this form. For example, if the normal form has a non-degenerate periodic solution, then the original system has a periodic solution close to that one. This follows from the implicit function theorem. Most of the invariant tori that exist for the normal form also exist, in the general case, for the original system. This follows from the results of KAM theory (one must use Theorem 6.17 in § 6.3). As always in systems with two degrees of freedom, the existence of invariant tori allows us to draw conclusions on stability.

If the characteristic frequencies of a system with two degrees of freedom do not satisfy resonance relations of order up to and including 4, then the equilibrium is stable (under the additional condition of isoenergetic non-degeneracy); this result was already discussed in § 6.3.6.B. For the remaining finitely many resonant cases the following result holds.

Theorem 8.8 ([191, 320, 408, 561, 562, 563]). *If the characteristic frequencies satisfy a resonance relation of order ≤ 4 , and the conditions of generality of position of § 8.3.2 hold, then the equilibrium of the original system is stable or unstable simultaneously with the equilibrium of the normal form.*

The stability can be proved by using KAM theory, and the instability, by comparing the rate of moving away from the equilibrium position for the original system and the normal form, or by constructing a Chetaev function.

³ In these papers it is assumed that to the multiple characteristic frequency there correspond, in the matrix of the linearized system, four Jordan blocks of order 1, rather than two blocks of order 2, that is, there is additional degeneracy: to obtain this case in a generic system four parameters are required.

In the notation of § 8.3.2 we have the following results.

Corollary 8.8 ([408]). *For the resonance (2, 1) the equilibrium is unstable if $B \neq 0$ (Fig. 8.3).*

Corollary 8.9 ([408]). *For the resonance (3, 1) the equilibrium is stable if $|A| > 3\sqrt{3}|B| > 0$ (Fig. 8.5), and unstable if $0 < |A| < 3\sqrt{3}|B|$ (Fig. 8.4).*

Corollary 8.10 ([320, 561, 563]). *If the linearized system has a multiple non-zero frequency with a pair of Jordan blocks of order 2, then the equilibrium of the full system is stable if $aD > 0$ (Fig. 8.9), and unstable if $aD < 0$ (Fig. 8.10).*

Corollary 8.11 ([191, 562]). *If the linearized system has a zero characteristic frequency with a Jordan block of order 2, then the equilibrium of the full system is unstable if $b \neq 0$ (Fig. 8.11).*

When some of the conditions of generality of position stated above are violated, the problem of stability was analysed in [191, 408, 561, 562].

The separatrices on the phase portraits of the normal form, generally speaking, split on passing to the exact system, as described in § 6.3.3.B.

8.4 Normal Forms of Hamiltonian Systems near Closed Trajectories

8.4.1 Reduction to Equilibrium of a System with Periodic Coefficients

Suppose that a Hamiltonian system with $n + 1$ degrees of freedom has a closed trajectory which is not an equilibrium position. Such trajectories are not isolated but, as a rule, form families. We now reduce the problem of the oscillations in a neighbourhood of this family to a convenient form.

Proposition 8.1 (see, for example, [154]). *In a neighbourhood of a closed trajectory there exist new symplectic coordinates $\varphi \bmod 2\pi$, J , and $z \in \mathbb{R}^{2n}$ such that $J = 0$ and $z = 0$ on the trajectory under consideration, and going around this trajectory changes φ by 2π ; on the trajectory itself, $\dot{\varphi} = \text{const}$. In the new coordinates the Hamiltonian function takes the form $H = f(J) + \mathcal{H}(z, \varphi, J)$, where $f'_J \neq 0$ and the expansion of \mathcal{H} in z , J begins with terms of the second order of smallness.*

We now perform the isoenergetic reduction (see [10]) choosing, on an energy level $H = h$, the phase φ for the new time (which we now denote by t). The Hamiltonian of the problem takes the form $F = F(z, t, h)$. For $h = 0$ the origin is an equilibrium position of the system. Suppose that this equilibrium is non-degenerate (all the multipliers are distinct from 1; the degenerate case is considered in § 8.4.3). Then for small h the system also has a non-degenerate equilibrium. By a change of variables smooth in the parameter one can shift this equilibrium to the origin. The Hamiltonian takes the form

$$F = \frac{1}{2}(\Xi(t, h)z, z) + G(z, t, h), \quad (8.14)$$

where the expansion of G in z begins with terms of the third order of smallness; the Hamiltonian has period 2π in t .

We now consider the linearized system.

Theorem 8.9 (see, for example, [614]). *A linear Hamiltonian system that is 2π -periodic in time can be reduced to an autonomous form by a linear symplectic change of variables. If the system has no negative real multipliers, then the reducing change of variables can be chosen to be 2π -periodic in time, and if the system has negative real multipliers, then 4π -periodic. If the system depends smoothly on a parameter, then the change of variables can also be chosen to be smooth in this parameter.*

Suppose that all the multipliers of the linearized system lie on the unit circle and are all distinct. Then, by the theorem stated above and by § 8.2.2, the Hamiltonian (8.14) can be reduced by a linear 2π -periodic change of variables to the form

$$\Phi = \frac{1}{2}\omega_1(p_1^2 + q_1^2) + \cdots + \frac{1}{2}\omega_n(p_n^2 + q_n^2) + \Psi(p, q, t, h), \quad (8.15)$$

where the expansion of Ψ in the phase variables begins with terms of the third order of smallness, and Ψ has period 2π in time t .

8.4.2 Reduction of a System with Periodic Coefficients to Normal Form

Definition 8.4. The characteristic frequencies $\omega_1, \dots, \omega_n$ satisfy a *resonance relation of order $l > 0$ for 2π -periodic systems* if there exist integers k_0, k_1, \dots, k_n such that $k_1\omega_1 + \cdots + k_n\omega_n + k_0 = 0$ and $|k_1| + \cdots + |k_n| = l$.

Theorem 8.10 (Birkhoff [14]). *Suppose that the characteristic frequencies ω_i of the 2π -periodic system (8.15) do not satisfy any resonance relation of order L or less. Then there is a symplectic change of variables that is 2π -periodic in time and reduces the Hamiltonian function to the same Birkhoff normal form of degree L as if the system were autonomous, with the only difference that the remainder terms of degree $L + 1$ and higher depend 2π -periodically on time.*

The normalization procedure is similar to the one described in § 8.3.1. If the system depends smoothly on a parameter, then the normalizing transformation can also be chosen to be smooth in the parameter.

For resonant cases one uses resonant normal forms. Let K be a sublattice of the integer lattice \mathbb{Z}^{n+1} defining the possible resonances (cf. § 6.1.1).

Definition 8.5. A *non-autonomous resonant normal form of degree L* for a Hamiltonian for resonances in K is a polynomial of degree L in symplectic variables P_i, Q_i which in the polar coordinates (8.9) depends on the phases φ_i and time t only via their combinations $k_1\varphi_1 + \dots + k_n\varphi_n + k_0t$ with $(k_1, \dots, k_n, k_0) \in K$.

Theorem 8.11. *Suppose that the characteristic frequencies do not satisfy any resonance relations of order L or less, except, possibly, for relations $k_1\omega_1 + \dots + k_n\omega_n + k_0 = 0$ with $(k_1, \dots, k_n, k_0) \in K$. Then there exists a symplectic 2π -periodic change of variables reducing the Hamiltonian to a non-autonomous resonant normal form of degree L for resonances in K up to terms of degree higher than L .*

If the rank of the sublattice K is equal to r , then a system in a normal form for resonances in K has $n - r$ independent integrals in involution which are linear combinations of the quantities $\rho_i = (P_i^2 + Q_i^2)/2$ with integer coefficients. In particular, if there is only one resonance relation, then the system is integrable.

8.4.3 Phase Portraits of Systems with Two Degrees of Freedom near a Closed Trajectory at a Resonance

In a system with two degrees of freedom the oscillations about a closed trajectory are described by a time-periodic system with one degree of freedom depending on a parameter (§ 8.4.1). A system having a resonant normal form for such a problem reduces to a system with one degree of freedom; its phase portraits can be drawn. If the coefficients of the lower terms of the normal form are generic, then there exists only finitely many types of phase portraits for this resonance, and these types are determined by the lower terms of the normal form. The phase portraits differ qualitatively only for finitely many resonances. The list of them and the description of the bifurcations that the portraits undergo when the parameters of the system pass through an exact resonance are contained in [150, 152] and are reproduced below.

The normal forms H_{k,k_0} for resonances (k, k_0) in the variables $\rho, \psi = \varphi + k_0t/k + \psi_0$ have the form

$$\begin{aligned} H_{3,k_0} &= \delta\rho + B\rho^{3/2} \cos 3\psi, \\ H_{k,k_0} &= \delta\rho + \rho^2 A(\rho) + B\rho^{k/2} \cos k\psi, \quad k \geq 4. \end{aligned}$$

Here ρ and ψ are conjugate phase variables, $\delta = \omega + k_0/k$ is the resonance detuning, A is a polynomial in ρ , and B, ψ_0 are constants. The required genericity conditions are $B \neq 0, A(0) \neq 0$ for $k \geq 4$, $|A(0)| \neq |B|$ for $k = 4$. All the coefficients depend also on a parameter h . We assume that $d\delta/dh \neq 0$, so that we can use δ instead of h . Under these conditions a small change in B and in the coefficients of A does not cause bifurcations; hence we can ignore the dependence of A and B on the parameter. We assume that $B > 0$ and $A(0) > 0$; this does not cause any loss of generality.

The metamorphosis of the phase portrait as δ increases passing through zero is shown for $k = 3$ in Fig. 8.12a; for $k = 4$ in Fig. 8.12b if $A(0) < B$, and in Fig. 8.12c if $A(0) > B$; and for $k = 5$ in Fig. 8.12d.

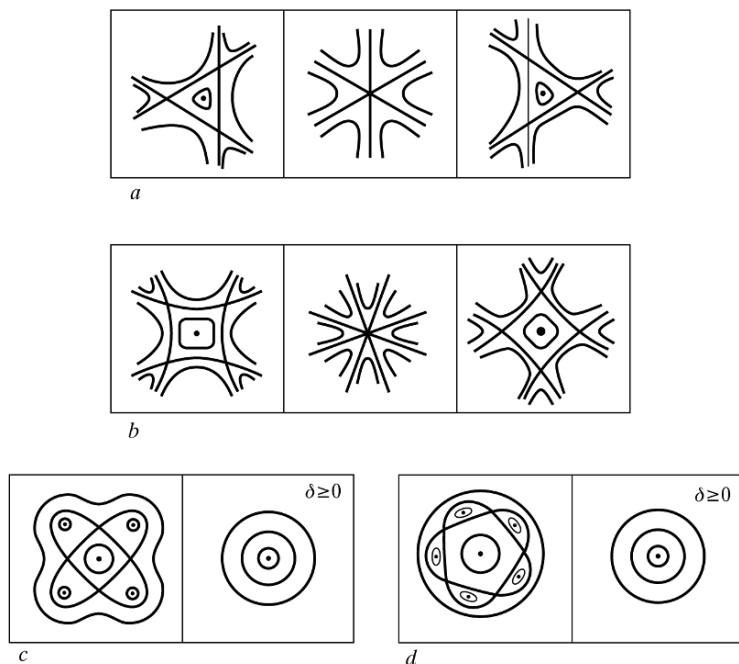

Fig. 8.12.

For $k \geq 6$ the metamorphosis is the same as for $k = 5$, only there are $2k$ singular points around the origin, rather than 10. For $k \geq 5$ these singular points are at a distance of order $\sqrt{\delta}$ from the origin. The “oscillation islands” surrounding stable points have width of order $\delta^{(k-2)/4}$. Consequently, for $k \geq 5$ these islands occupy only a small proportion of the neighbourhood of the origin under consideration, and the other phase curves are close to circles.

There are two more resonant cases which are already related to the quadratic terms of the Hamiltonian. These are the cases where the multipliers of a closed trajectory are equal to -1 or 1 .

If the multipliers are close to -1 (resonance $(2, k_0)$), then in the typical case the lower terms of the Hamiltonian can be reduced by a 4π -periodic change of variables to the normal form

$$H = \delta q^2 + \frac{ap^2}{2} + Dq^4, \quad a = \pm 1.$$

The metamorphosis is shown in Fig. 8.13a for $a = 1$ and $D > 0$, and in Fig. 8.13b for $a = 1$ and $D < 0$.

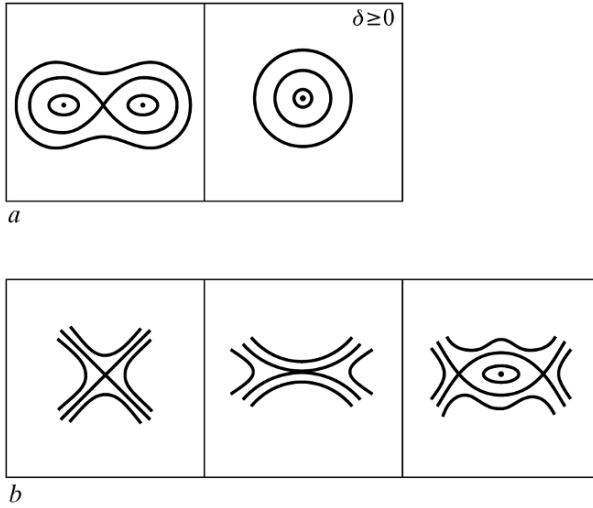

Fig. 8.13.

If the multipliers are close to 1 (resonance $(1, k_0)$), then the lower terms of the Hamiltonian can be reduced to the normal form

$$H = \delta q^2 + \frac{ap^2}{2} + bq^3, \quad a = \pm 1.$$

The metamorphosis is shown in Fig. 8.14 (under the assumption that $a = 1$ and $b > 0$).

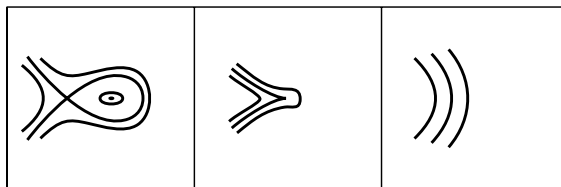

Fig. 8.14.

The phase portraits constructed here allow one to determine many properties of the original system when its lower terms can be reduced to the corresponding normal form. For example, to non-degenerate equilibrium positions on the portraits there correspond periodic trajectories of the full system going over the original periodic trajectory k times. For a resonance of order 3 there is only one such trajectory, it is unstable and merges with the original one at the instant of the exact resonance ($\delta = 0$). For a resonance of order $k \geq 5$ there are two such trajectories, one is stable, the other is unstable; they branch off from the original trajectory at passing through the resonance along the δ -axis in one definite direction. For a resonance of order 4, depending on the values of the parameters, the picture is either the same as for order 3, or as for order $k \geq 5$. At passing through a resonance of order 2 (the multipliers are equal to -1) the original trajectory loses or acquires stability, and a periodic trajectory branches off which goes twice over it. Finally, for a resonance of order 1 (the multipliers are equal to 1) the original trajectory vanishes merging with another trajectory with the same period (or, if we move in the opposite direction along the parameter, two periodic trajectories are born).

To most of the closed curves on the phase portraits there correspond two-dimensional invariant tori of the full system carrying conditionally periodic motions (according to KAM theory).

Under the genericity conditions stated above, the stability or instability of the original closed trajectory can be determined by using the normal form (cf. Theorem 8.8). For $k = 3$ we have instability if $B \neq 0$; for $k = 4$, stability if $|A(0)| > |B| > 0$, and instability if $0 < |A(0)| < |B|$; for $k \geq 5$, stability if $A(0)B \neq 0$. For the multipliers equal to -1 we have stability if $aD > 0$, and instability if $aD < 0$. For the multipliers equal to 1 we have instability if $ab \neq 0$.

When we pass from the normal form to the exact system, the separatrices that are present on the phase portraits, generally speaking, split similarly to what was described in §6.3.3.B.

8.5 Stability of Equilibria in Conservative Fields

8.5.1 Lagrange–Dirichlet Theorem

Theorem 8.12 (Lagrange–Dirichlet). *If the potential has a strict local minimum at an equilibrium position, then the corresponding equilibrium state is stable.*

◁ For a Lyapunov function we can take the total mechanical energy. ▷

The hypothesis of the Lagrange–Dirichlet theorem is not a necessary condition for stability.

Example 8.3 (Painlevé–Wintner). Consider the infinitely differentiable potential $U(q) = (\cos q^{-1}) \exp(-q^{-2})$, where $q \neq 0$; $U(0) = 0$. The equilibrium position $q = 0$ is stable, although the point $q = 0$ is of course not a local minimum of the function U (Fig. 8.15).

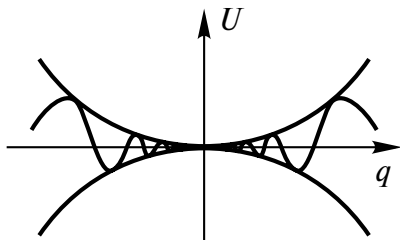

Fig. 8.15.

△

In 1892 Lyapunov posed the problem of proving the converse of Lagrange's theorem for the case in which the coefficients of the quadratic form $T = \sum a_{ij}(q)\dot{q}_i\dot{q}_j$ and the potential U are analytic functions in a neighbourhood of the equilibrium position. A detailed survey of papers on Lyapunov's problem up to 1983 is contained in [24].

Theorem 8.13. *Suppose that the equilibrium position $q = 0$ is not a local minimum of an analytic potential U . Then the equilibrium state $(\dot{q}, q) = (0, 0)$ is unstable.*

This result was established by Palamodov in [491]. Earlier he proved the converse of the Lagrange–Dirichlet theorem for systems with two degrees of freedom.

The proof of Theorem 8.13 is based on the following assertion going back to Chetaev [180]. We assume that the matrix of kinetic energy $(a_{ij}(q))$ at the point $q = 0$ is the identity matrix. This can be achieved by a suitable linear change of coordinates.

Lemma 8.1 ([180, 24]). *Suppose that in some neighbourhood Q of the point $q = 0$ there exists a vector field v such that*

- 1) $v \in C^1(Q)$ and $v(0) = 0$,
- 2) $\langle v'\xi, \xi \rangle \geq \langle \xi, \xi \rangle$ for all $\xi \in \mathbb{R}^n$ and $q \in Q$,
- 3) $\langle v, U' \rangle = PU$, where P is positive and continuous in $Q \cap \{U(q) < 0\}$.

Then any motion $q(\cdot)$ of the mechanical system with negative energy leaves the domain Q in finite time.

Remark 8.2. Let $q(\cdot)$ be a motion with zero total energy. If the equilibrium position $q = 0$ is isolated, then (under the assumptions of Lemma 8.1) the point $q(t)$ either leaves some domain $|q| \leq \varepsilon_0$ in finite time, or tends to zero as $t \rightarrow \infty$.

The main difficulty in the proof of Palamodov's theorem is precisely in the construction of the required field v . This construction is based on the technique of resolution of singularities, which is often used in algebraic geometry.

Example 8.4. Suppose that U is a quasi-homogeneous function with quasi-homogeneity exponents $\alpha_1, \dots, \alpha_n \in \mathbb{N}$:

$$U(\lambda^{\alpha_1} x_1, \dots, \lambda^{\alpha_n} x_n) = \lambda^\alpha U(x_1, \dots, x_n), \quad \alpha \in \mathbb{N}.$$

Then for the field v one can take the field Aq , where $A = \text{diag}(\alpha_1, \dots, \alpha_n)$. Indeed, $\langle v, U' \rangle = \alpha U$ by the Euler formula. \triangle

Remark 8.3. Of special interest is the case where the potential energy has a *non-strict* minimum. Laloy and Pfeiffer [365] proved that such critical points of an analytic potential of a system with two degrees of freedom are unstable equilibrium positions. This problem is so far unsolved in the multidimensional case.

The problem of converses to the Lagrange–Dirichlet theorem is interesting not only in the analytic but also in the smooth case, where the absence of a minimum of the potential energy is determined by its Maclaurin series. Let

$$U = U_2 + U_k + U_{k+1} + \dots \tag{8.16}$$

be the formal Maclaurin series of the potential U , where U_s is a homogeneous form of degree s in q_1, \dots, q_n . In a typical situation, of course, $k = 3$.

If the first form U_2 does not have a minimum at the equilibrium position $q = 0$, then this equilibrium is unstable. In this case one of the eigenvalues is positive, and therefore the instability follows from the well-known theorem of Lyapunov.

Therefore we consider the case where $U_2 \geq 0$. We introduce the plane

$$II = \{q: U_2(q) = 0\}.$$

If $\dim II = 0$, then the form U_2 is positive definite and therefore the equilibrium $q = 0$ is stable by Theorem 8.12. We assume that $\dim II \geq 1$. Let W_k be the restriction of the form U_k in the expansion (8.16) to the plane II . We have the following.

Theorem 8.14 ([333]). *If the form W_k does not have a minimum at the point $q = 0$, then this equilibrium is unstable.*

The proof of Theorem 8.14 is based on the following idea: if the equations of motion have a solution $q(t)$ that asymptotically tends to the point $q = 0$ as $t \rightarrow +\infty$, then the equilibrium state $(q, \dot{q}) = (0, 0)$ is unstable. Indeed, in view of the reversibility property, the equations of motion have also the solution $t \mapsto q(-t)$, which asymptotically goes out of the equilibrium position.

Under the hypotheses of Theorem 8.14 an asymptotic solution can be represented as a series in negative powers of time:

$$\sum_{s=1}^{\infty} \frac{x_s(\ln t)}{t^{s\mu}}, \quad \mu = \frac{2}{k-2}, \tag{8.17}$$

where $x_s \in \mathbb{R}^n$, and each component of the vector-function $x_s(\cdot)$ is a polynomial with constant coefficients.

Suppose that $U_2 = 0$ and the Maclaurin series (8.16) converges. Then (as established in [328, 357]) the series (8.17) converges for $t \geq t_0$. Furthermore, in the case of odd k the coefficients x_s are altogether independent of time.

If $U_2 \neq 0$, then the series (8.17) are, as a rule, divergent even in the analytic case.

Example 8.5. Consider the system of equations

$$\ddot{x} = \frac{\partial U}{\partial x}, \quad \ddot{y} = \dot{x}^2 - \frac{\partial U}{\partial y}; \quad U = -4x^3 + \frac{y^2}{2}. \tag{8.18}$$

The presence of the summand \dot{x}^2 models the case where the kinetic energy is non-Euclidean. Equations (8.18) have the formal solution

$$x = \frac{1}{2t^2}, \quad y = \frac{1}{t^6} \sum_{n=0}^{\infty} \frac{a_{2n}}{t^{2n}}, \quad a_{2n} = \frac{(-1)^n (2n+5)!}{120}. \tag{8.19}$$

The radius of convergence of the power series for y is zero.

However, equations (8.18) have the following exact asymptotic solutions corresponding to the formal series (8.19):

$$x = \frac{1}{2t^2}, \quad y(t) = -\sin t \int_t^{\infty} \frac{\cos s}{s^6} ds + \cos t \int_t^{\infty} \frac{\sin s}{s^6} ds$$

By performing successive integration by parts, from the last formula we obtain the divergent series (8.19). This series is an asymptotic expansion of the function $y(t)$ as $t \rightarrow +\infty$. △

According to Kuznetsov’s theorem [364], with each series (8.17) formally satisfying the equations of motion one can associate a genuine solution for which this series is an asymptotic expansion as $t \rightarrow +\infty$:

$$q(t) - \sum_{s=1}^N \frac{x_s}{t^{s\mu}} = o\left(\frac{1}{t^{N\mu}}\right)$$

Note that the paper [364] appeared precisely in connection with the discussion of the range of questions related to Theorem 8.14. Problems of constructing asymptotic solutions of strongly nonlinear systems of differential equations are considered in detail in the book [350].

We point out two important consequences of Theorem 8.14.

a) As we already noted, the question of stability of non-degenerate equilibria (at which $\det(\partial^2 U/\partial q^2) \neq 0$) is decided by the Lagrange–Dirichlet theorem. By Theorem 8.14, degenerate equilibria are unstable in a typical situation. Indeed, in the general case the expansion (8.16) involves terms of degree 3, and therefore $W_3 \neq 0$. It remains to observe that a non-zero form of degree 3 cannot have a minimum.

b) Equilibria of a mechanical system in a conservative force field with a harmonic potential (satisfying the Laplace equation $\Delta U = 0$) are unstable. A special case is “Earnshaw’s theorem”: an equilibrium of a system of electric charges in a stationary electric field is always unstable. Before the papers [328, 357] Earnshaw’s theorem had been proved only for the case where the eigenvalues of the first approximation are non-zero.

Indeed, harmonic functions are analytic. We expand the potential in the convergent Maclaurin series:

$$U = U_k + U_{k+1} + \dots, \quad k \geq 2.$$

Suppose that $U_k \neq 0$ (otherwise $U = 0$ and then all points q will obviously be unstable equilibrium positions). Clearly, U_k is also a harmonic function. By the mean value theorem, U_k does not have a minimum at zero, whence the instability follows (Theorem 8.14).

8.5.2 Influence of Dissipative Forces

Suppose that a mechanical system is in addition acted upon by non-conservative forces $F(q, \dot{q})$; the motion is described by Lagrange’s equation

$$\frac{d}{dt} \left(\frac{\partial L}{\partial \dot{q}} \right) - \frac{\partial L}{\partial q} = F, \quad L = T - U. \quad (8.20)$$

Definition 8.6. We call the force F a *force of viscous friction with total dissipation* if $F(q, 0) = 0$ and $(T + U)' = F\dot{q} < 0$ for $\dot{q} \neq 0$.

Even after addition of forces of viscous friction, the equilibrium positions will again coincide with the critical points of the potential U . The equilibrium states that were stable by Lagrange’s theorem remain stable with dissipation of energy taken into account. Moreover, if the potential is an analytic function, then these equilibrium states become asymptotically stable. This is the Kelvin–Chetaev theorem [181].

Theorem 8.15 (see [327]). *Suppose that the point $q = 0$ is not a local minimum of the function U , and $U(0) = 0$. The equilibrium state $(q, \dot{q}) = (0, 0)$ of system (8.20) is unstable if one of the following conditions holds:*

- a) *the function U is analytic in a neighbourhood of the point $q = 0$;*
- b) *the function U is smooth and has no critical points in the domain $\Sigma_\varepsilon = \{q: U(q) < 0, |q| < \varepsilon\}$ for some $\varepsilon > 0$.*

In the analytic case condition b) holds automatically.

◁ Consider a motion $q(\cdot)$ with negative total energy and therefore with $q(0) \in \Sigma_\varepsilon$. We claim that the point $q(t)$ leaves Σ_ε in a finite time. Indeed, on such a motion we have $\dot{q}(t) \neq 0$. Consequently, the total energy $E = T + U$ monotonically decreases. If $q(t) \in \Sigma_\varepsilon$ for all $t > 0$, and $E(t)$ tends to a finite limit as $t \rightarrow +\infty$, then $\dot{q}(t) \rightarrow 0$. But for small values of the speed the friction forces are small compared to the conservative forces, which impart a sufficiently high velocity to the system. ▷

8.5.3 Influence of Gyroscopic Forces

Suppose that, apart from dissipative forces, the mechanical system is also acted upon by additional gyroscopic forces

$$F = \Omega(\dot{q}, \cdot),$$

where Ω is a closed 2-form (the form of gyroscopic forces; see §3.2). Since gyroscopic forces do not perform any work, the equilibrium states that were stable by the Lagrange–Dirichlet theorem remain stable after addition of gyroscopic forces. Moreover, if the dissipation is total and the potential U satisfies the hypotheses of Theorem 8.15, then equilibrium states cannot be stabilized by adding gyroscopic forces.

Suppose that $q = 0$ is a non-degenerate equilibrium. Poincaré called the Morse index of the potential U at this point the *degree of instability* of the equilibrium $q = 0$.

Theorem 8.16 (Kelvin–Chetaev [181]). *If the degree of instability is odd, then this equilibrium cannot be stabilized by adding dissipative and gyroscopic forces.*

The proof is based on verifying the fact that if the degree of instability is odd, then among the eigenvalues there necessarily exists a positive one.

However, if the degree of instability is even, then such an equilibrium in the absence of dissipative forces can be stabilized by suitable gyroscopic forces.

Example 8.6. It is well known that the motion of a charge in an electric \mathbf{E} and magnetic \mathbf{H} fields is described by the equation

$$m\dot{\mathbf{v}} = e\left(\mathbf{E} + \frac{1}{c}[\mathbf{v}, \mathbf{H}]\right), \tag{8.21}$$

where $\mathbf{v} = \dot{\mathbf{x}}$ is the velocity of the charge ($\mathbf{x} \in \mathbb{R}^3$) and c is the speed of light. We consider a stationary electromagnetic field (when \mathbf{E} and \mathbf{H} do not explicitly depend on time). The field \mathbf{E} is conservative: $\mathbf{E} = -\text{grad } \varphi$. The magnetic component of the Lorentz force is a gyroscopic force: its presence does not affect the conservation of the total energy

$$W = \frac{mv^2}{2} + \varphi.$$

If $\mathbf{H} = 0$, then all the equilibria (stationary points of the potential φ) are unstable by Earnshaw’s theorem.

We now give a simple example showing that it is possible to stabilize unstable equilibria by a stationary magnetic field [347]. Suppose that the electric field \mathbf{E} is created by two equal charges Q situated on the x_3 -axis at a distance R from the origin O . Then the point O is an unstable equilibrium position. The potential of the electric field is equal to $\varphi_+ + \varphi_-$, where

$$\varphi_{\pm} = eQ [x_1^2 + x_2^2 + (R \pm x_3)^2]^{-1/2}$$

The expansion of the total energy W in the Maclaurin series has the form

$$W = \frac{m(v_1^2 + v_2^2 + v_3^2)}{2} - \frac{eQ(x_1^2 + x_2^2 - 2x_3^2)}{R^3} + \dots$$

If $eQ > 0$ (which we assume in what follows), then the degree of instability (the Morse index of the function W at the critical point $\mathbf{x} = \mathbf{v} = 0$) is equal to two. However, if the charges e and Q have opposite signs, then the degree of instability is odd (equal to one) and a gyroscopic stabilization is impossible by the Kelvin–Chetaev theorem.

We introduce the magnetic field $\mathbf{H} = (0, 0, \varkappa)$, $\varkappa = \text{const}$, which of course satisfies Maxwell’s equations. Since the kinetic energy and the electromagnetic field are invariant under rotations around the x_3 -axis, equations (8.21) admit the Nöther integral

$$\Phi = m(v_1x_2 - v_2x_1) + \frac{e\varkappa}{2c}(x_1^2 + x_2^2).$$

We seek a Lyapunov function in the form of a combination of integrals $W + \lambda\Phi$, where $\lambda = \text{const}$. Choosing λ so that this integral takes minimum value we obtain the following sufficient condition for the Lyapunov stability:

$$H^2 > \frac{8Qmc^2}{eR^3}.$$

△

Theorem 8.16 can be extended to systems of the most general form. Let v be a smooth vector field on $\mathbb{R}^n = \{x\}$. This field generates the dynamical system

$$\dot{x} = v(x), \quad x \in \mathbb{R}^n. \quad (8.22)$$

Suppose that $x = 0$ is an equilibrium position: $v(0) = 0$. Then in a neighbourhood of this point system (8.22) has the form

$$\dot{x} = Ax + o(|x|),$$

where A is the Jacobi matrix of the field v at the point $x = 0$. We define the *degree of instability* $\deg(x = 0)$ of the equilibrium $x = 0$ to be the number of eigenvalues of the matrix A with positive real part (counting multiplicities). This definition generalizes Poincaré's definition of degree of instability for classical mechanical systems. In particular, if the degree of instability is odd, then the characteristic equation $\det(A - \lambda E) = 0$ has a positive root. We say that the equilibrium $x = 0$ is *non-degenerate* if $\det A \neq 0$.

Suppose that there exists a smooth function $F: \mathbb{R}^n \rightarrow \mathbb{R}$ such that

$$\dot{F} = \frac{\partial F}{\partial x} v \leq 0.$$

We say that such a system is *dissipative*. The function F kind of plays the role of the total energy. It is easy to verify that the non-degenerate critical points of the function F correspond to the equilibria of system (8.22).

Theorem 8.17 ([341]). *Suppose that $x = 0$ is a non-degenerate equilibrium which is a non-degenerate critical point of the function F . Then*

$$\deg(x = 0) = \text{ind}_0 F \pmod{2}.$$

In this equality on the right is the Morse index of the function F at the critical point $x = 0$.

Corollary 8.12. *Suppose that F is a Morse function. Then its critical points of odd index are unstable equilibria.*

This assertion includes the Kelvin–Chetaev theorem (Theorem 8.16). Indeed, let $W = T + U$ be the energy integral of a reversible system. Its index at an equilibrium position is obviously odd. This index does not change after addition of gyroscopic forces. Since $\dot{W} \leq 0$ after addition of dissipative forces, the instability of the equilibrium follows from Corollary 8.12 of Theorem 8.17.

Tensor Invariants of Equations of Dynamics

A tensor invariant is a tensor field in the phase space that is invariant under the action of the phase flow. The most frequently occurring invariants are first integrals, symmetry fields, invariant differential forms. Closely related to them there are objects of more general nature: frozen-in direction fields and integral invariants. Tensor invariants play an essential role both in the theory of exact integration of equations of dynamics and in their qualitative analysis.

9.1 Tensor Invariants

9.1.1 Frozen-in Direction Fields

Let M be a smooth manifold, v a vector field on M generating the dynamical system

$$\dot{x} = v(x), \quad x \in M, \quad (9.1)$$

and let $\{g^t\}$ be its phase flow.

Let $a(x) \neq 0$ be another smooth vector field on M . Passing through each point $x \in M$ there is a unique integral curve of the field a (at each of its points x this curve is tangent to the vector $a(x)$). We say that this family of integral curves is *frozen* into the flow of system (9.1) if it is mapped into itself under all transformations g^t .

A criterion for the integral curves of the field a to be frozen-in is that the equality

$$[a, v] = \lambda a \quad (9.2)$$

holds, where $[\ , \]$ is the commutator of vector fields and λ is some smooth function on M .

◁ To prove (9.2) we use the theorem on rectification of the integral curves of the field a : in some local coordinates x_1, \dots, x_n the components of the field a

have the form $1, 0, \dots, 0$. Condition (9.2) is equivalent to the equalities

$$\frac{\partial v_1}{\partial x_1} = \lambda, \quad \frac{\partial v_2}{\partial x_1} = \dots = \frac{\partial v_n}{\partial x_1} = 0, \tag{9.3}$$

where the v_i are the components of the field v . Since in these coordinates the integral lines of the field a are given by the equations $x_k = \text{const}$, $k \geq 2$, and the components v_k , $k \geq 2$, are independent of x_1 , this family of lines is mapped into itself under the transformations g^t (see Fig. 9.1).

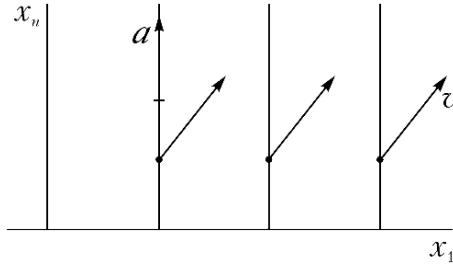

Fig. 9.1.

Conversely, if relations (9.3) are violated, then some of the components v_2, \dots, v_n of the field v take different values for different values of the coordinate x_1 , and therefore the phase flow $\{g^t\}$ will distort the coordinate lines $x_k = \text{const}$, $k \geq 2$. ▷

Condition (9.2) for $n = 3$ was first obtained by Poincaré as a generalization of Helmholtz’s theorem on the property of the vortex lines (the integral curves of the field of the curl of the velocity) being frozen into the flow of an ideal barotropic fluid in a conservative force field. In the non-autonomous case, the integral curves of the field $a(x, t)$ are considered for fixed values of time t , and condition (9.2) is replaced by the more general condition

$$\frac{\partial a}{\partial t} + [a, v] = \lambda a.$$

The form of relation (9.2) clearly does not change when the field a is replaced by μa , where μ is any smooth function of x . Consequently, this relation is independent of the lengths of the vectors $a(x)$. Thus, equality (9.2) can be regarded as a condition for the *direction field being* (invariant) *frozen into* the phase flow of the field v .

If $\lambda = 0$, then the field a is a *symmetry field* for system (9.1). Note that, in contrast to the problem of symmetry fields, finding frozen-in direction fields is a nonlinear problem: apart from the field a in (9.2) the factor λ is also an unknown quantity.

9.1.2 Integral Invariants

We denote the Lie derivative along the vector field v by L_v . By the homotopy formula we have

$$L_v = di_v + i_v d,$$

where i_v is the inner product of the field v and the differential form: $i_v \omega = \omega(v, \cdot)$.

Let φ be a k -form, γ a k -chain, and $\{g_v^t\}$ the phase flow of system (9.1). We have the following simple formula:

$$\left. \frac{d}{dt} \right|_{t=0} \int_{g^t(\gamma)} \varphi = \int_{\gamma} L_v \varphi.$$

Thus, if

$$L_v \varphi = 0, \tag{9.4}$$

then the integral

$$I[\gamma] = \int_{\gamma} \varphi \tag{9.5}$$

is an *absolute integral invariant* for system (9.1):

$$I[g^t(\gamma)] = I[\gamma] \quad \forall t \in \mathbb{R}. \tag{9.6}$$

If

$$L_v \varphi = d\psi, \tag{9.7}$$

where ψ is some $(k - 1)$ -form, then equality (9.6) is valid for any k -cycle γ : $\partial\gamma = 0$. In this case the integral (9.5) is called a *relative integral invariant*.

The division of integral invariants into absolute and relative ones, which was suggested by Poincaré, does not provide for all interesting cases. For example, it may happen that

$$L_v \varphi = \psi, \quad d\psi = 0, \tag{9.8}$$

and the k -form ψ is not exact. In this case equality (9.4) holds for any k -dimensional cycle homologous to zero. We say that such an integral invariant is *conditional*.

We give a simple example of a linear integral invariant which is conditional but not relative. In (9.1), let

$$\begin{aligned} M^2 &= \mathbb{T} \times \mathbb{R} = \{q \bmod 2\pi, p\}, \\ \dot{x} = v(x): \quad \dot{q} &= 0, \quad \dot{p} = 1; \quad \varphi = p \, dq. \end{aligned}$$

Then

$$L_v \varphi = i_v d\varphi = dq.$$

The form $\psi = dq$ is closed but not exact. Hence,

$$\dot{I}[g^t(\gamma)] = 2\pi$$

for any closed contour γ “encircling” the cylinder M (for example, for $\gamma = \{0 \leq q < 2\pi, p = 0\}$).

Suppose that a k -form φ generates a conditional or relative integral invariant. Then to the $(k + 1)$ -form $d\varphi$ there obviously corresponds an absolute invariant. Indeed,

$$L_v d\varphi = dL_v \varphi = d\psi = 0.$$

This remark is in fact due to Poincaré ([41], § 238).

Cartan attaches a somewhat different meaning to the notion of integral invariant. According to Cartan, absolute integral invariants are generated by differential forms α such that

$$i_v \alpha = i_v d\alpha = 0. \tag{9.9}$$

Cartan called such forms *integral forms* in his book [18]. In view of the homotopy formula, equality (9.9) immediately implies the equality $L_v \alpha = 0$.

Relative integral invariants are generated (according to Cartan) by forms α such that

$$i_v d\alpha = 0. \tag{9.10}$$

Equality (9.10) yields

$$L_v \alpha = di_v \alpha + i_v d\alpha = d\beta,$$

where $\beta = i_v \alpha$. Thus, we obtain a special case of the relative integral invariant according to Poincaré.

Cartan’s approach to the theory of integral invariants seems to be more narrow in comparison with Poincaré’s approach. However, as Cartan wrote in the introduction to his book, “But it turns out that the notion of integral form is not essentially different from the notion of integral invariant. It is the comparison of these two notions that is the basis of the present work”.

The main idea of Cartan is based on extending the phase space M by adding time t as a new independent variable. In the extended $(n + 1)$ -dimensional space $\widetilde{M} = M \times \mathbb{R}$, equation (9.1) is replaced by the system

$$\dot{x} = v(x), \quad \dot{t} = 1. \tag{9.11}$$

Proposition 9.1. *Suppose that a k -form φ generates an absolute invariant of system (9.1) according to Poincaré. Then system (9.11) admits the absolute invariant according to Cartan generated by the k -form*

$$\alpha = \varphi + (-1)^k (i_v \varphi) \wedge dt.$$

The proof amounts to verifying two equalities: $i_{\tilde{v}}\alpha = 0$ and $L_{\tilde{v}}\alpha = 0$, where \tilde{v} is the vector field on the extended space defined by equations (9.11). Proposition 9.1 is in fact due to Cartan ([18], §30); only, rather than the explicit formula for α , Cartan gives a rule for deriving it: instead of the differentials dx_i , one must substitute the differences $dx_i - v_i dt$ into the expression for the form φ .

As noted by Cartan ([18], §32), Proposition 9.1 is not valid for relative invariants in the general case. We supplement Cartan’s observation by the following assertion.

Proposition 9.2. *Suppose that a k -form φ generates a conditional integral invariant according to Poincaré of system (9.1): $i_v d\varphi = d\psi$. Then system (9.11) admits a conditional invariant k -form according to Cartan: $i_{\tilde{v}}\alpha = 0$, where*

$$\alpha = \varphi + (-1)^{k-1}\psi \wedge dt. \tag{9.12}$$

Cartan himself actually used formula (9.12) in certain concrete situations. However, in the general case he suggested acting differently ([18], §32): if system (9.1) admits a conditional invariant, then it also admits an absolute invariant; after this reduction one can already use Proposition 9.1.

Let σ_1 be a closed k -dimensional surface in \tilde{M} . By constructing an integral curve of the vector field \tilde{v} through each point of σ_1 we obtain a $(k+1)$ -dimensional tube of trajectories Γ . Let σ_2 be another k -dimensional surface lying on Γ and homologous to σ_1 (that is, the cycle $\sigma_1 - \sigma_2$ is the boundary of some piece of Γ ; see Fig. 9.2). In view of condition (9.10), the $(k+1)$ -form $d\alpha$ vanishes on Γ . Consequently, by Stokes’ theorem we have

$$\int_{\sigma_1} \alpha = \int_{\sigma_2} \alpha. \tag{9.13}$$

Now let σ_1 and σ_2 be the sections of the tube Γ by the hypersurfaces $t = t_1$ and $t = t_2$. Then in equality (9.13) the form α can be replaced by φ , and we pass to a Poincaré invariant of the original system (9.1).

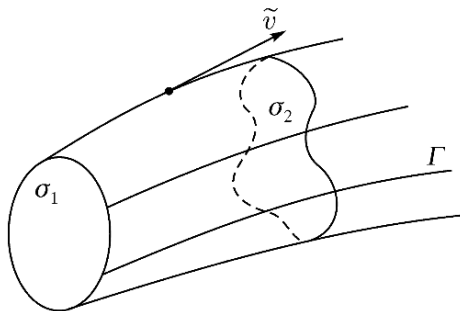

Fig. 9.2.

9.1.3 Poincaré–Cartan Integral Invariant

Now let $M^{2n} = T^*N^n$ be the phase space of a Hamiltonian system with configuration space $N^n = \{x\}$. We introduce the canonical momenta $y \in T_x^*N$ and the 1-form

$$\varphi = y \, dx = \sum_1^n y_k \, dx_k.$$

As noted by Poincaré ([41], § 255), Hamilton’s equations

$$\dot{x}_k = \frac{\partial H}{\partial y_k}, \quad \dot{y}_k = -\frac{\partial H}{\partial x_k}; \quad 1 \leq k \leq n, \tag{9.14}$$

admit the linear relative invariant

$$\int_{\gamma} \sum y_k \, dx_k, \quad \partial\gamma = 0 \tag{9.15}$$

(Corollary 1.7 in § 1.3.6).

It is interesting to note that the invariant (9.15) is independent of the Hamiltonian H in equations (9.14). Therefore the invariant (9.15) is sometimes called a *universal* integral invariant. Lee [374] proved that every linear universal invariant of Hamilton’s equations may differ from the Poincaré invariant (9.15) only by a constant factor. However, this result is of formal nature. Its proof is based on the analysis of invariance of the integral of one and the same 1-form φ under the phase flows of Hamiltonian systems with different concrete Hamiltonians.

It is worth emphasizing that Lee’s theorem was proved for the case where $M = \mathbb{R}^{2n}$. If the first Betti number of the phase space M is non-zero, then this theorem is no longer valid. One can add a closed but not exact 1-form to the form φ . Then the value of the integral (9.15) on cycles non-homologous to zero changes by some non-zero additive constants. In the general case Lee’s theorem holds only for conditional integral invariants.

Let v be the Hamiltonian vector field defined by the differential equations (9.14). It is easy to see that system (9.14) can be represented in the equivalent form

$$i_v d\varphi = -dH.$$

According to Proposition 9.2 the extended Hamiltonian system admits the relative integral invariant

$$\int (\varphi - H) dt. \tag{9.16}$$

The invariant (9.16) is called the *Poincaré–Cartan integral invariant*, and the integrand $\sum y dx - H dt$ is called the *energy–momentum form*. Another proof of the invariance of (9.16) was given in § 1.3.6.

As noted by Cartan ([18], § 11), the existence of the integral invariant (9.16) uniquely specifies the Hamiltonian system (9.14).

Poincaré posed the problem of the existence of other integral invariants of equations of dynamics, in particular, in the three-body problem. In [41], § 257 he wrote: “It may be asked whether there are other algebraic integral invariants in addition to those which we have just formed. Either the method of Bruns, or the method which I employed in Chaps. 4 and 5, may be employed.”

Poincaré understood that this problem is closely connected with conditions for integrability of Hamilton’s equations. It is not an accident that he mentions Chapter 5, where he proved the theorem on the non-existence of single-valued analytic integrals under a typical perturbation of the Hamiltonian function. We now show that, indeed, in a neighbourhood of an invariant torus, a completely integrable system admits several different relative integral invariants. In the action–angle variables the equations have the form

$$\dot{J}_1 = \dots = \dot{J}_n = 0, \quad \dot{\varphi}_1 = \omega_1, \dots, \dot{\varphi}_n = \omega_n, \quad (9.17)$$

where the ω_k are functions of J . Consider the non-degenerate case where

$$\frac{\partial(\omega_1, \dots, \omega_n)}{\partial(J_1, \dots, J_n)} \neq 0.$$

It turns out that equations (9.17) can be represented in different non-equivalent Hamiltonian forms [340]. We set

$$\varphi = \sum_1^n \frac{\partial K}{\partial \omega_k} d\varphi_k,$$

and the Hamiltonian function H is equal to

$$\sum_1^n \omega_k \frac{\partial K}{\partial \omega_k} - K.$$

Here K is a non-degenerate function of the frequencies $\omega_1, \dots, \omega_n$:

$$\det \left(\frac{\partial^2 K}{\partial \omega_i \partial \omega_j} \right) \neq 0.$$

Different Hamiltonians of representations of equations (9.17) are “numbered” by the functions $K(\omega)$. Therefore, by Poincaré’s theorem, system (9.17) admits the integral invariants

$$\oint \varphi = \oint \sum_1^n \frac{\partial K}{\partial \omega_k} d\varphi_k.$$

Poincaré himself tried to connect the existence of new integral invariants with the properties of the multipliers of periodic solutions of Hamilton’s equations. He showed ([41], § 259) that if there are p distinct integral invariants (when the 1-forms φ are independent), and the coefficients of the forms φ are linear in the canonical variables (as, for example, in (9.15)), then p of the

multipliers are equal to one. Unfortunately, for the general case the analysis of the problem carried out by Poincaré did not yield definitive results. In this connection Poincaré wrote: “It is probable that the three-body problem permits no other algebraic invariant relationships except those which are already known. I am still not able to prove this.” ([41], § 258).

For some simplified variants of the three-body problem Poincaré’s conjecture was proved in [344] (see § 9.4).

9.2 Invariant Volume Forms

9.2.1 Liouville’s Equation

In § 1.3 we proved the important Liouville theorem on the conservation of the phase volume of Hamiltonian systems (Corollary 1.10 in § 1.3.6).

More generally, system (9.1) on M^n admits the integral invariant

$$\int_D \rho(x) d^n x \quad (9.18)$$

if and only if

$$\operatorname{div} \rho v = \sum_{i=1}^n \frac{\partial \rho v_i}{\partial x_i} = 0. \quad (9.19)$$

This equation is called *Liouville’s equation*, and the function ρ is called the *density* of the integral invariant. For Hamiltonian systems, $\rho \equiv 1$. If $\rho > 0$, then the integral (9.18) is often called an invariant measure: its value can be taken for a measure of a domain D . Thus,

$$\operatorname{meas} (g^t D) = \operatorname{meas} D,$$

where g^t is a transformation in the phase flow of system (9.1).

For equations (9.17), Liouville’s equation takes the form

$$\sum \omega_k \frac{\partial \rho}{\partial \varphi_k} = 0.$$

Under the assumption of non-degeneracy, this equation has solutions depending only on the action variables: $\rho = \rho(J_1, \dots, J_n)$. It turns out that every such invariant measure is a *Liouville measure* [340]: it can be obtained by taking the n th power of the differential of the 1-form $\varphi = \sum \partial K / \partial \omega_k d\varphi_k$ in § 9.1.3. If we take the frequencies ω for the action variables J , then the measure with density $\rho(J)$ is Liouville if and only if

$$\det \left(\frac{\partial^2 K}{\partial J_i \partial J_j} \right) = \rho(J).$$

This is the classical *Monge–Ampère equation*, which is well known to be locally soluble with respect to the function K if the function ρ is positive.

Remark 9.1. Strictly speaking, a measure and the integral of a volume form are not the same thing. For instance, the flow of the vector field $\partial/\partial\varphi$ on the Möbius strip

$$S^1 \times \mathbb{R} \text{ mod } (\varphi, y \mapsto \varphi + 2\pi, -y)$$

preserves the ordinary measure, but does not admit invariant 2-forms ($dy \wedge d\varphi$ is not a form on the Möbius strip because it is not orientable). A measure is defined by a volume form only on an oriented manifold.

9.2.2 Condition for the Existence of an Invariant Measure

According to the Krylov–Bogolyubov theorem, any dynamical system on a compact manifold has at least one invariant measure (see [475], and a modern exposition in [555]). However, in the general case these measures are singular and are not in any way connected with the smooth structure of the phase space: they can be concentrated on finitely many trajectories (for example, on asymptotically stable equilibrium positions).

We indicate some general conditions for the existence of an invariant measure with smooth density for system (9.1). Since the density ρ is positive, Liouville’s equation (9.19) can be rewritten in the form

$$\dot{f} = -\operatorname{div} v, \quad \text{where} \quad f = \ln \rho. \tag{9.20}$$

Clearly, f is a smooth function on M .

By the theorem on rectification of trajectories, in a small neighbourhood of a non-singular point system (9.1) can be reduced to the form

$$\dot{z}_1 = 1, \quad \dot{z}_2 = \dots = \dot{z}_n = 0. \tag{9.21}$$

Consequently, system (9.1) locally admits a whole family of invariant measures: their densities are arbitrary functions of z_2, \dots, z_n . Thus, it makes sense to consider the problem of an integral invariant either in a neighbourhood of equilibrium positions, or in sufficiently large domains of the phase space, where the trajectory has the recurrence property (for example, in the entire manifold M^n).

Theorem 9.1 ([334]). *Let $t \mapsto x(t)$ be a solution of system (9.1) with compact closure of its trajectory. If system (9.1) admits an invariant measure with smooth density, then there exists*

$$\lim_{s \rightarrow \infty} \frac{1}{s} \int_0^s (\operatorname{div} v)_{x(t)} dt = 0. \tag{9.22}$$

◁ The proof of this assertion is simple. Let $x(t) \in D$, where D is a compact subdomain of M . By (9.20) we have

$$\lim_{s \rightarrow \infty} \frac{1}{s} \int_0^s (\operatorname{div} v) dt = \lim_{s \rightarrow \infty} \frac{f(x(0)) - f(x(s))}{s} = 0,$$

since the continuous function f is bounded above and below on the set D . ▷

We point out several corollaries of Theorem 9.1.

Corollary 9.1. *Suppose that $x = 0$ is an equilibrium position of a nonlinear system*

$$\dot{x} = \Lambda x + \dots \tag{9.23}$$

If $\text{tr } \Lambda \neq 0$, then in a neighbourhood of the point $x = 0$ this system does not have an integral invariant with smooth positive density.

◁ Indeed, in this case $(\text{div } v)_{x=0} = \text{tr } \Lambda$. It remains to use formula (9.22) for the solution $x(t) \equiv 0$. ▷

It is interesting to note that the condition $\text{tr } \Lambda = 0$ means that the phase flow of the linear system $\dot{x} = \Lambda x$ preserves the standard volume form in \mathbb{R}^n . Thus, if a linear system with constant coefficients has at least one invariant measure, then this system necessarily admits the standard invariant measure (with unit density). Applications of Corollary 9.1 for certain problems of non-holonomic dynamics are contained in [334].

Now suppose that system (9.1) on M^n , $n = m + k$, has a k -dimensional invariant torus \mathbb{T}^k filled with the trajectories of conditionally periodic motions. In a small neighbourhood of this torus one can introduce coordinates

$$x_1, \dots, x_k \pmod{2\pi}, \quad y_1, \dots, y_m$$

in which equations (9.1) take the form

$$\dot{x} = \omega + f(x, y), \quad \dot{y} = \Omega y + g(x, y). \tag{9.24}$$

Here $\omega = (\omega_1, \dots, \omega_k)$ is a non-resonant set of frequencies of conditionally periodic motions on \mathbb{T}^k , $f(x, 0) = 0$, and $g(x, y) = O(|y|^2)$. The invariant torus is obviously given by the equation $y = 0$. The elements of the square matrix Ω of order m are 2π -periodic functions of x_1, \dots, x_n .

Corollary 9.2. *If system (9.24) admits an invariant measure with smooth density, then*

$$\int_0^{2\pi} \dots \int_0^{2\pi} (\text{tr } \Omega) dx_1 \dots dx_n = 0. \tag{9.25}$$

◁ Indeed, by Weyl's theorem on uniform distribution we have

$$\lim_{s \rightarrow \infty} \frac{1}{s} \int_0^s (\text{div } v) dt = \frac{1}{(2\pi)^k} \int_{\mathbb{T}^k} (\text{tr } \Omega) d^k x$$

for the solutions $x = \omega t + x_0$, $y = 0$. It remains to use Theorem 9.1. ▷

For $k = 0$ the matrix Ω has constant elements, and we arrive at Corollary 9.1: the sum of the eigenvalues of the matrix A is equal to zero. By the Floquet–Lyapunov theorem, for $k = 1$ there is a linear change of coordinates y that is 2π -periodic in x and reduces the matrix Ω to a constant matrix. The eigenvalues of the matrix $\exp(2\pi\Omega/\omega)$ are called the multipliers of the periodic trajectory \mathbb{T}^1 ($k = 1$). Corollary 9.2 gives us a necessary condition for the existence of an invariant measure in a neighbourhood of a periodic trajectory on an oriented manifold: the product of its multipliers is equal to one. If M is non-orientable, then this assertion also remains valid if we go twice over the periodic trajectory: the multipliers must be defined as the eigenvalues of the linearization of the Poincaré return map over the doubled period.

If the matrix Ω can be reduced to a constant matrix, then such an invariant torus is said to be *reducible*. A discussion of the problem of reducibility of tori for $k > 1$ can be found in [297, 586]. For reducible tori, condition (9.25) becomes the simple equality $\text{tr } \Omega = 0$.

Corollary 9.1 admits a certain refinement. Let us calculate the divergence of the right-hand side of system (9.23) and expand it in the Maclaurin series:

$$-\text{div } v = \text{tr } A + (a, x) + \dots,$$

where a is some constant vector in \mathbb{R}^n .

Proposition 9.3 ([334]). *Let $X = A^T$ and $Y = (X, a)$. If $\text{rank } X < \text{rank } Y$, then system (9.23) does not have an invariant measure in a neighbourhood of the point $x = 0$.*

If the matrix A is non-singular, then the ranks of the matrices X and Y are equal automatically.

In applications there occur systems with homogeneous right-hand sides: $v(\lambda x) = \lambda^k v(x)$ with some integer $k \geq 1$. For such systems a criterion for the existence of an invariant measure with smooth density is given by the following proposition.

Proposition 9.4 ([335]). *A system of differential equations with homogeneous right-hand sides has an invariant measure if and only if its phase flow preserves the standard measure. In this case the density of an invariant measure is a first integral of this system.*

We point out an interesting application of this assertion to the *Euler–Poincaré equations* on Lie algebras, which describe the geodesic lines on Lie groups with a left-invariant metric (or, which is the same, the free motion of a mechanical system whose kinetic energy is invariant under the left translations on the Lie group – the configuration space of the system). As is well known (see § 1.2.4), the Euler–Poincaré equations, have the following form:

$$\dot{m}_i = \sum c_{ik}^l m_l \omega_k, \quad \dot{m}_s = \sum I_{sp} \omega_p.$$

For $\varepsilon = 0$ system (9.26) is completely integrable: the phase space $\Delta \times \mathbb{T}^2$ is foliated into the invariant tori $z = \text{const}$ with conditionally periodic motions. We say that the unperturbed system is *non-degenerate* if the frequency ratio u_0/v_0 is a non-constant function of z ; in other words, if $u'_0 v_0 - u_0 v'_0 \neq 0$ at least at one point of the interval Δ .

For non-degenerate systems, the first equation (9.28) implies that f_0 is a function only of the variable z . Let bar denote the averaging over the variables x, y :

$$\bar{F} = \frac{1}{4\pi^2} \int_0^{2\pi} \int_0^{2\pi} F(x, y, z) dx dy.$$

Applying the averaging operation to the second equation of system (9.28) we obtain

$$\frac{df_0}{dz} \bar{w}_1 = -\frac{d\bar{w}_1}{dz}.$$

This relation leads to the *averaging principle* established in [334]: the function \bar{f}_0 is the density of an integral invariant of the averaged system

$$\dot{z} = \varepsilon \bar{w}_1. \tag{9.29}$$

Passing from the full system (9.26) to the averaged one (9.29) is a standard methods of perturbation theory. We point out one of the consequences of the averaging principle: if the function \bar{w}_1 has an isolated zero, then the full system (9.26) does not admit an invariant measure with density $\rho = \exp f$, where f is defined in the form of a series (9.27).

We set

$$\begin{aligned} w_1 &= \sum W_{mn}(z) \exp [i(mx + ny)] \\ \frac{\partial u_1}{\partial x} + \frac{\partial v_1}{\partial y} + \frac{\partial w_1}{\partial z} &= -\sum G_{mn}(z) \exp [i(mx + ny)] \\ f_1 &= \sum F_{mn}(z) \exp [i(mx + ny)]. \end{aligned}$$

Equating the coefficients of the same harmonics in the second equation (9.28) we arrive at the sequence of equalities

$$f'_0 W_{mn} + i(mu_0 + nv_0) F_{mn} = G_{mn}. \tag{9.30}$$

Suppose that for $z = z_0$ a non-trivial resonance relation $mu_0 + nv_0 = 0$ is satisfied with some integers m, n . If $W_{mn}(z_0) = 0$ and $G_{mn}(z_0) \neq 0$, then equation (9.30) is contradictory and the original system (9.26) does not admit a measure with single-valued density that is analytic in the parameter ε .

Suppose that $W_{mn}(z_0) \neq 0$. Note that for $z = z_0$ we obviously have the relations

$$f'_0 W_{km, kn} = G_{km, kn}, \quad k \in \mathbb{Z}.$$

If

$$W_{m, n} G_{km, kn} \neq W_{km, kn} G_{m, n}$$

for at least one integer k , then system (9.26) also does not have invariant measures with single-valued analytic densities.

This method was applied in [334] for studying conditions for the existence of invariant measures of equations of non-holonomic mechanics. More precisely, consider the mechanical system with configuration space in the form of the three-dimensional torus $\mathbb{T}^3 = \{\varphi_1, \varphi_2, \varphi_3 \text{ mod } 2\pi\}$, with the Lagrangian $L = (\dot{\varphi}_1^2 + \dot{\varphi}_2^2 + \dot{\varphi}_3^2)/2$ (there are no external forces), and with the constraint

$$\dot{\varphi}_3 = \varepsilon(a_1\dot{\varphi}_1 + a_2\dot{\varphi}_2), \tag{9.31}$$

where ε is a small parameter. For $\varepsilon = 0$ the constraint (9.31) is integrable, and we have an ordinary holonomic system, which has an invariant measure (by the classical Liouville theorem). In the general case (where $\varepsilon \neq 0$) the constraint (9.31) is of course non-integrable. Tatarinov suggested calling systems with constraints of the form (9.31) *weakly non-holonomic*.

To within terms $o(\varepsilon)$, the equations of motion have the form

$$\dot{\varphi}_1 = J_1, \quad \dot{\varphi}_2 = J_2, \quad \dot{\varphi}_1 = \varepsilon(a_1 J_1 + a_2 J_2), \quad \dot{J}_1 = \dot{J}_2 = 0.$$

The slow variables are the frequencies J_1 and J_2 , as well as the angle coordinate φ_3 . Here the unperturbed system proves to be degenerate; but one can apply to it the above method for finding the density of an invariant measure in the form of a series in powers of ε .

The results of analysis of this problem can be stated in the following geometric form. The set of all systems with the Lagrangian L and with the constraint (9.31) has the natural structure of an infinite-dimensional vector space (isomorphic to the space of pairs of functions a_1 and a_2 on a three-dimensional torus); we denote this subspace by \mathbb{K} . All systems having an invariant measure (in the first approximation with respect to ε) form a vector subspace $\mathbb{K}' \subset \mathbb{K}$. In exactly the same way, systems with integrable constraint (9.31) form a vector subspace \mathbb{K}'' . Indeed, the condition for the integrability of the relation (9.31) in the first approximation with respect to ε has the form

$$\frac{\partial a_1}{\partial \varphi_2} = \frac{\partial a_2}{\partial \varphi_1}.$$

This condition is linear in a_1 and a_2 . By Liouville's theorem, $\mathbb{K}'' \subset \mathbb{K}'$. It turns out that

$$\dim \mathbb{K}/\mathbb{K}' = \infty, \quad \text{and} \quad \dim \mathbb{K}'/\mathbb{K}'' = \infty.$$

The first relation shows that the existence of an invariant measure with smooth density is a rare exception among non-holonomic systems. The second relation indicates the existence of a massive set of non-holonomic systems with

invariant measure that cannot be reduced to holonomic systems. Among them there are, in particular, the *Chaplygin systems* (where the functions a_1 and a_2 are independent of φ_3), which, in the first approximation with respect to ε , satisfy all the conditions for applicability of the method of reducing factor, which guarantees the existence of an integral invariant (see [165]). It would be interesting to find out whether these conclusions are valid for small fixed values of $\varepsilon \neq 0$ (rather than only in the first approximation with respect to the parameter ε).

9.3 Tensor Invariants and the Problem of Small Denominators

9.3.1 Absence of New Linear Integral Invariants and Frozen-in Direction Fields

Poincaré’s idea about a connection between the problem of linear integral invariants and the problem of small denominators ([41], § 257) was realized in [342]. Therein the system of equations (9.26) with a small parameter ε was considered, which frequently occurs in the theory of nonlinear oscillations.

In [342] there was considered the problem of conditions for the existence of a relative integral invariant

$$\oint \varphi_\varepsilon \tag{9.32}$$

of system (9.26) such that the coefficients of the 1-form φ_ε are single-valued analytic functions on $\Delta \times \mathbb{T}^2$ depending analytically on ε . Of course, we should exclude the trivial case where

$$d\varphi_\varepsilon = 0; \tag{9.33}$$

under this condition the integral (9.32) is identically equal to zero by Stokes’ theorem.

We expand the function w_1 in the double Fourier series:

$$w_1 = \sum W_{mn}(z) \exp [i(mx + ny)].$$

We introduce the set $\mathbb{P} \subset \Delta$ consisting of the points z such that

- 1) $mu_0(z) + nv_0(z) = 0$ for some integers m, n that are not simultaneously equal to zero, and
- 2) $W_{mn}(z) \neq 0$.

Such sets were first considered by Poincaré in connection with the problem of integrability of Hamilton’s equations (§ 7.1).

The paper [348] contains the solution, for equations (9.26), of the problem of conditions for the existence of frozen-in direction fields in the form of series

in powers of ε : $a = a_0 + \varepsilon a_1 + \dots$, where the a_s are analytic vector-functions on $\Delta \times \mathbb{T}^2$. We say that a direction field a is *trivial* if $a = \mu v$; in this case the phase trajectories of system (9.1) are frozen-in. We assume that the condition of non-triviality of the direction field is satisfied for $\varepsilon = 0$: $a_0 \neq \mu v_0$. In accordance with what was said in §9.1.1 we also assume that $a_0 \neq 0$; otherwise some of the integral curves of the field a_0 cease to be regular and degenerate into points.

Theorem 9.3 ([342, 348]). *Suppose that*

- (A) *the set \mathbb{P} has a limit point z_* inside Δ , and*
- (B) $u'_0 v_0 - u_0 v'_0|_{z_*} \neq 0$.

Then system (9.26) does not have a non-trivial frozen-in field of directions analytic in ε . If in addition

- (C) $W_{00}(z) \neq 0$,

then system (9.26) does not have a non-trivial integral invariant of the form (9.32).

Condition (B) means that the unperturbed system (where $\varepsilon = 0$) is non-degenerate: the frequency ratio u_0/v_0 is non-constant. Furthermore, it follows from (B) that for $z = z_*$ and $\varepsilon = 0$ the right-hand sides of (9.26) do not vanish. Conditions (A)+(B) guarantee that there are no non-constant analytic integrals or non-trivial symmetry fields analytic in ε (cf. §7.1).

9.3.2 Application to Hamiltonian Systems

We can attempt to apply Theorem 9.3 to Hamiltonian systems that are nearly completely integrable. Here the question can be about systems with two degrees of freedom whose order is reduced by one by using the energy integral. Applying Whittaker's method we can transform the reduced system to the form of a non-autonomous Hamiltonian system with time-periodic Hamiltonian.

Thus, we consider the Hamilton equation

$$\begin{aligned} \dot{x} &= 1, & \dot{y} &= \frac{\partial H}{\partial z}, & \dot{z} &= -\frac{\partial H}{\partial y}, \\ H_\varepsilon &= H_0(z) + \varepsilon H_1(x, y, z) + \dots \end{aligned} \tag{9.34}$$

Here $y \bmod 2\pi$, z are canonical action-angle variables of the unperturbed system, and the function H is assumed to be 2π -periodic in the "time" $x = t$.

For system (9.34) we have

$$u_0 = 1, \quad v_0 = \frac{\partial H_0}{\partial z}, \quad w_1 = -\frac{\partial H_1}{\partial y}. \tag{9.35}$$

Consequently, condition (B) is equivalent to the non-degeneracy of the unperturbed Hamiltonian:

$$\frac{d^2 H_0}{dz^2} \neq 0. \tag{9.36}$$

The set \mathbb{P} obviously coincides with the set

$$\left\{ z \in \Delta: \frac{dH_0}{dz} = -\frac{n}{m}, \quad H_{mn} \neq 0 \right\}, \tag{9.37}$$

where the H_{mn} are the Fourier coefficients of the perturbing function H_1 . In a typical situation, \mathbb{P} fills Δ everywhere densely. Consequently, by Theorem 9.3 equations (9.34) do not admit non-trivial frozen-in direction fields (in particular, non-trivial symmetry fields). Furthermore, it follows from (9.35) that condition (C) is never satisfied for Hamiltonian systems ($W_{00} \equiv 0$). However, this is hardly surprising: equations (9.34) have the Poincaré–Cartan integral invariant

$$\oint z \, dy - H_\varepsilon \, dx. \tag{9.38}$$

This invariant is obviously non-trivial (the degeneracy condition (9.33) does not hold).

We now indicate sufficient conditions for the non-existence of a second integral invariant. For that we shall need the following.

Lemma 9.1 ([344]). *Suppose that conditions (A) and (B) of Theorem 9.3 are satisfied. Then there exists a function*

$$\lambda_\varepsilon = \lambda_0(z) + \varepsilon \lambda_1(z) + \dots$$

such that

$$d\varphi_\varepsilon = i_v(\lambda_\varepsilon \Omega), \tag{9.39}$$

where v_c is the vector field of system (9.26) and $\Omega = dx \wedge dy \wedge dz$.

We now show how the conclusion of Theorem 9.3 can be derived from this lemma. We integrate the 2-forms on both sides of (9.39) over a two-dimensional torus $z = \text{const}$. By Stokes’ theorem the integral of the form $d\varphi$ is equal to zero, while the integral on the right-hand side is equal to

$$\lambda_\varepsilon W_{00} + o(\varepsilon).$$

Applying condition (C) we obtain that $\lambda_\varepsilon = 0$. Hence equality (9.39) will coincide with the degeneracy condition (9.33).

Lemma 9.2. *If (9.39) holds, then the 3-form $\lambda\Omega$ generates an absolute integral invariant of system (9.26).*

◁ Indeed,

$$0 = dd\varphi = di_v(\lambda\Omega) = di_v(\lambda\Omega) + i_v d(\lambda\Omega) = L_v(\lambda\Omega). \quad \triangleright$$

Lemma 9.3. *Suppose that system (9.26) has another absolute invariant generated by a 3-form $\lambda'\Omega$ such that $\lambda' \neq 0$. Then the ratio λ/λ' is an integral of equations (9.26).*

This simple fact (albeit in different terminology) was pointed out by Jacobi in his “Lectures on dynamics” (1866).

It is well known that the phase flow of Hamilton’s equations (9.34) preserves the “standard” volume 3-form Ω . Moreover, the “energy–momentum” 1-form in (9.38) satisfies equality (9.39) with $\lambda_\varepsilon = 1$.

Theorem 9.4 ([344]). *Suppose that condition (9.36) holds and the set (9.37) has a limit point inside the interval Δ . Then any conditional integral invariant of the Hamiltonian system (9.34) differs from the Poincaré–Cartan invariant (9.38) by a constant factor c_ε .*

◁ Suppose that system (9.34) has an integral invariant of the form (9.32). Since conditions (A) and (B) of Theorem 9.3 are satisfied, equality (9.39) holds. We now take into account that $L_v\Omega = 0$. Then, by Lemmas 9.2 and 9.3 the factor λ_ε in (9.39) is an integral of system (9.34). However, $\lambda_\varepsilon = c_\varepsilon = \text{const}$ under the hypotheses of Theorem 9.4 (cf. § 7.1). Thus,

$$d\varphi_\varepsilon = c_\varepsilon d(zdy - H_\varepsilon dx).$$

Hence the values of the integrals (9.32) and (9.38) on cycles homologous to zero differ by the factor c_ε , as required. ▷

Remark 9.2. Suppose that

- 1) $u'_0v_0 - u_0v'_0 \neq 0$,
- 2) \mathbb{P} is everywhere dense in Δ ,
- 3) system (9.26) admits a non-trivial invariant of the form (9.32).

One can show that then any other conditional integral invariant of system (9.26) differs from (9.32) by a constant factor that depends analytically on ε .

Theorem 9.4 can be applied to the planar restricted circular three-body problem. Here the role of the small parameter ε is played by the ratio of Jupiter’s mass to the mass of the Sun. The dynamics of the third body of a negligible mass (asteroid) in the rotating frame (where the Sun and Jupiter are stationary) is described by the following Hamilton equations (see § 7.1.3):

$$\begin{aligned} \dot{q}_k &= \frac{\partial H}{\partial p_k}, & \dot{p}_k &= -\frac{\partial H}{\partial q_k}; & k &= 1, 2, \\ H &= H_0 + \varepsilon H_1 + \dots, & H_0 &= -\frac{1}{2p_1^2} - p_2. \end{aligned} \tag{9.40}$$

The expansion of the perturbing function in the double Fourier series has the form

$$H_1 = \sum_{u=-\infty}^{\infty} \sum_{v=-\infty}^{\infty} h_{uv} \cos [uq_1 - v(q_1 + q_2)].$$

The coefficients h_{uv} depending on p_1, p_2 are in general non-zero. Taking the angle variable q_2 for a new “time” and applying Whittaker’s procedure for reducing the order we arrive at Hamilton’s equations of the form (9.34) with

$$H_0(z) = -\frac{1}{2z^2}.$$

Therefore condition (9.36) is satisfied automatically. One can show that the set \mathbb{P} is everywhere dense on the half-axis $z > 0$. Thus, the reduced Hamilton equations of the restricted three-body problem do not have new relative integral invariants that are analytic in the parameter ε and independent of the Poincaré–Cartan invariant.

9.3.3 Application to Stationary Flows of a Viscous Fluid

Theorem 9.3 was applied in [342] for finding a reason for the absence of linear conditional integral invariants for flows of a viscous incompressible fluid. As is well known, in the non-viscous case the circulation of fluid over a moving contour is conserved. This is the celebrated *Helmholtz–Thomson theorem*. Furthermore, there is a frozen-in direction field, namely, the field of curl, which is not collinear with the flow’s velocity in the typical situation.

The flow of a homogeneous fluid (the density ρ is constant) in a conservative force field is described by the Navier–Stokes equation

$$\frac{d\mathbf{v}}{dt} = -\text{grad} \left(\frac{p}{\rho} + V \right) + \nu \Delta \mathbf{v}. \tag{9.41}$$

Here \mathbf{v} is the field of velocities, p is pressure, V is the potential energy of the field of forces, ν is the viscosity coefficient. For simplicity we shall write p instead of $p/\rho + V$. By the assumption of homogeneity, the continuity equation amounts to the incompressibility condition

$$\text{div } \mathbf{v} = 0. \tag{9.42}$$

We shall consider stationary flows where the field of velocities \mathbf{v} and the function p do not explicitly depend on time. In this case the field \mathbf{v} generates the divergence-free dynamical system

$$\dot{x} = \mathbf{v}(x), \tag{9.43}$$

whose phase flow preserves the standard volume in $\mathbb{R}^3 = \{x\}$.

Let u, v, w be the components of the vector field \mathbf{v} . It is easy to understand that equations (9.41)–(9.42) admit the following particular solutions:

$$\begin{aligned} u_0 = \alpha z + \xi, \quad v_0 = \beta z + \eta, \quad w_0 = 0, \quad p = p_0, \\ \alpha, \beta, \xi, \eta, p_0 = \text{const.} \end{aligned} \tag{9.44}$$

A solution of the form (9.44) corresponds to a translational planar-parallel flow.

We seek stationary solutions of the system of equations (9.41)–(9.42) in the form of power series

$$\begin{aligned} u = u_0 + \varepsilon u_1 + \dots, \quad v = v_0 + \varepsilon v_1 + \dots, \quad w = \varepsilon w_1 + \dots, \\ p = p_0 + \varepsilon p_1 + \dots \end{aligned} \tag{9.45}$$

Here ε is a small parameter, and the coefficients are analytic functions of x, y, z that are 2π -periodic in x, y . Substituting the series (9.45) into (9.41)–(9.42) and equating the coefficients of ε we obtain the linear system

$$\begin{aligned} u_0 \frac{\partial u_1}{\partial x} + v_0 \frac{\partial u_1}{\partial y} + w_1 \alpha + \frac{\partial p_1}{\partial x} &= \nu \Delta u_1, \\ u_0 \frac{\partial v_1}{\partial x} + v_0 \frac{\partial v_1}{\partial y} + w_1 \beta + \frac{\partial p_1}{\partial y} &= \nu \Delta v_1, \\ u_0 \frac{\partial w_1}{\partial x} + v_0 \frac{\partial w_1}{\partial y} + \frac{\partial p_1}{\partial z} &= \nu \Delta w_1, \\ \frac{\partial u_1}{\partial x} + \frac{\partial v_1}{\partial y} + \frac{\partial w_1}{\partial z} &= 0. \end{aligned} \tag{9.46}$$

We now solve this system by the Fourier method. Denoting the Fourier coefficients of the functions u_1, v_1, w_1, p_1 by $U_{mn}, V_{mn}, W_{mn}, P_{mn}$, respectively, we obtain the linear equations

$$\begin{aligned} i[m(\alpha z + \xi) + n(\beta z + \eta)]U_{mn} + \alpha W_{mn} + im P_{mn} &= \nu[-(m^2 + n^2)U_{mn} + U''_{mn}], \\ i[m(\alpha z + \xi) + n(\beta z + \eta)]V_{mn} + \beta W_{mn} + in P_{mn} &= \nu[-(m^2 + n^2)V_{mn} + V''_{mn}], \\ i[m(\alpha z + \xi) + n(\beta z + \eta)]W_{mn} + P'_{mn} &= \nu[-(m^2 + n^2)W_{mn} + W''_{mn}], \\ i(mU_{mn} + nV_{mn}) + W'_{mn} &= 0. \end{aligned} \tag{9.47}$$

If $\nu \neq 0$, then equations (9.47) form a system of ordinary differential equations, which is of the second order with respect to U_{mn}, V_{mn} , and of the first order with respect to W_{mn}, P_{mn} . Consequently, to uniquely determine these coefficients we must set their values and the values of the derivatives U'_{mn}, V'_{mn} at some point $z = z_0$.

The Fourier coefficients of the functions u_k, v_k, w_k , and p_k ($k \geq 2$) can be found by induction. The question of convergence of the series (9.45) is a

non-trivial problem, which, however, has an affirmative solution for the so-called crawling flows (or Stokes flows) where the derivatives $\dot{\mathbf{v}}$ are neglected in equations (9.41); see [342].

Taking into account the expansions (9.45) we see that system (9.43) is precisely of the form (9.26); hence we can attempt to apply Theorem 9.3 to (9.43). First of all we verify condition (B). It is clear that

$$mu_0 + nv_0 = (m\alpha + n\beta)z + m\xi + n\eta \equiv 0$$

only if simultaneously

$$m\alpha + n\beta = 0, \quad m\xi + n\eta = 0.$$

Since $m^2 + n^2 \neq 0$, we have $\alpha\eta - \beta\xi = 0$. Therefore, if

$$\alpha\eta - \beta\xi \neq 0,$$

then the unperturbed system is non-degenerate.

Now let us discuss condition (A). It is clear that $mu_0 + nv_0 = 0$ at the point

$$z_{mn} = -\frac{m\xi + n\eta}{m\alpha + n\beta}. \tag{9.48}$$

Of course, we can exclude from our consideration the pairs of integers m, n satisfying the condition $m\alpha + n\beta = 0$. Recall that the set \mathbb{P} consists of the points z_{mn} at which $W_{mn} \neq 0$. If $\nu \neq 0$, then the coefficients W_{mn} at these points can be chosen arbitrarily. Therefore, in the general case the set \mathbb{P} is everywhere dense on the axis $\mathbb{R} = \{z\}$. More precisely, this condition can be violated only on a subspace of infinite codimension in the space of all vector fields (9.45). By Theorem 9.3, a typical stationary flow of the form (9.45) does not admit non-trivial integrals, frozen-in direction fields, or integral invariants.

From this viewpoint it is interesting to consider the case of an ideal fluid, where $\nu = 0$. Here system (9.47) becomes degenerate: the first and second differential equations become algebraic. At the points z_{mn} these equations take the form

$$\alpha W_{mn} + im P_{mn} = 0, \quad \beta W_{mn} + in P_{mn} = 0.$$

Consequently, if $\alpha n - \beta m \neq 0$, then $W_{mn}(z_{mn}) = 0$ and therefore $z_{mn} \notin \mathbb{P}$. Since $\alpha^2 + \beta^2 \neq 0$, we see that in the case $\alpha n - \beta m = 0$ all the points (9.48) coincide. Thus, the set \mathbb{P} consists of at most one point, and, consequently, condition (A) is not satisfied for an ideal fluid.

9.4 Systems on Three-Dimensional Manifolds

We again return to system (9.1) and assume that M is a three-dimensional manifold, while v is a smooth tangent vector field without singular points.

Moreover, suppose that system (9.1) admits an invariant volume form Ω :

$$L_v \Omega = 0.$$

The volume form defines a canonical orientation of M . If M is compact, then we can assume that

$$\int_M \Omega > 0.$$

In particular, the form Ω defines a smooth invariant measure of system (9.1).

The most important example of systems of this type is provided by Hamiltonian systems with two degrees of freedom. Here M^3 is a connected component of a non-singular level surface of the Hamiltonian function, v is the restriction of the Hamiltonian field to M , and the volume form is defined by the invariant Liouville 4-form.

Lemma 9.4 (Cartan [18], §91). *Under the above assumptions, the 2-form*

$$\Phi = i_v \Omega \tag{9.49}$$

is closed and generates an absolute integral invariant of system (9.1).

◁ Indeed,

$$d\Phi = di_v \Omega = L_v \Omega - i_v d\Omega = 0, \quad L_v \Phi = L_v i_v \Omega = i_v L_v \Omega = 0. \quad \triangleright$$

Since the form (9.49) is closed, locally

$$\Phi = d\varphi.$$

Since $i_v \Phi = 0$, we have

$$L_v \varphi = i_v d\varphi + di_v \varphi = d(i_v \varphi).$$

Consequently, to the 1-form φ there corresponds a “local” relative integral invariant.

If the cohomology class of the 2-form Φ is equal to zero, then the 1-form φ is well defined globally. In particular, this is the case automatically if

$$H^2(M, \mathbb{R}) = 0. \tag{9.50}$$

These arguments are in fact contained in [18], §91, although therein the case $M = \mathbb{R}^3$ is considered.

Throughout what follows we assume that the manifold M^3 satisfies the partition of unity theorem. In particular, this includes compact manifolds.

Lemma 9.5. *Let Ψ be a smooth 2-form on M . There exists a vector field $x \mapsto u(x)$ such that*

$$\Psi = i_u \Omega. \tag{9.51}$$

◁ Indeed, let $\{\lambda_\alpha(x)\}$ be a partition of unity subordinate to some open covering of M . It is assumed that in the domains λ_α there exist global coordinates. It is easy to verify that in the domain $\text{supp } \lambda_\alpha$ the algebraic equation (9.49) for the 2-form $\lambda_\alpha \Psi$ has a unique smooth solution u_α such that

$$\text{supp } u_\alpha \subset \text{supp } \lambda_\alpha.$$

It remains to set

$$u(x) = \sum_{\alpha} u_\alpha(x). \quad \triangleright$$

Remark 9.3. In the analytic case, the field u is of course analytic.

Theorem 9.5. *Suppose that system (9.1) has a conditional integral invariant*

$$\oint \varphi.$$

Let

$$d\varphi = i_u \Omega. \quad (9.52)$$

Then the vector field u is a symmetry field: $[u, v] = 0$.

◁ By the definition of a conditional invariant we have

$$L_v \varphi = \psi, \quad d\psi = 0.$$

Consequently,

$$0 = dL_v \varphi = L_v d\varphi = L_v i_u \Omega = (L_v i_u - i_u L_v) \Omega = i_{[v, u]} \Omega.$$

Since the volume form is non-degenerate, the fields u and v commute, as required. ▷

Remark 9.4. Theorem 9.5 remains valid if the form $d\varphi$ in (9.52) is replaced with any closed 2-form.

Theorem 9.5 has important applications to Hamiltonian mechanics. As an example we consider a *geodesic flow* on a closed two-dimensional surface Σ . The flow is determined by a Riemannian metric. The equations of geodesics on Σ are described by Hamilton's equations, and the Hamiltonian H is the Riemannian metric represented in canonical coordinates on $T^*\Sigma$. It is well known that for positive values of the total energy h , the Hamiltonian systems on the three-dimensional energy surfaces

$$\{x \in T^*\Sigma : H(x) = h\} \quad (9.53)$$

are isomorphic. One usually sets $h = 1$; the corresponding dynamical system is called the *geodesic flow* on Σ . The geodesic flow clearly has the Poincaré–Cartan relative integral invariant.

Theorem 9.6 ([344, 338]). *Let Σ be an analytic surface of genus > 1 with an analytic Riemannian metric. Any analytic symmetry field of the geodesic flow on Σ is proportional to the Hamiltonian field on (9.53), and any conditional invariant defined by an analytic 1-form on (9.53) is proportional to the Poincaré–Cartan invariant.*

◁ The absence of non-trivial symmetry fields of geodesic flows on surfaces of genus > 1 was established in [338]. Another proof based on variational methods is contained in [126]. We now show how to derive from this the absence of non-trivial linear integral invariants.

Let Ω be an invariant analytic volume 3-form on (9.53). If the geodesic flow has a conditional integral invariant defined by an analytic 1-form φ , then (by Theorem 9.5) there exists an analytic symmetry field u . However, a geodesic flow on an analytic surface of genus > 1 does not have non-trivial symmetries:

$$u = cv, \quad c = \text{const.}$$

But then according to (9.52) we have

$$d\varphi = c i_v \Omega.$$

Consequently, the conditional integral invariant under consideration differs from the Poincaré–Cartan invariant by the constant factor c . ▷

In conclusion of this subsection we indicate yet another application of the results obtained above to one of the restricted variants of the three-body problem. Suppose that two massive bodies of equal masses are revolving around their common centre of mass in elliptic orbits with non-zero eccentricity, while the third body of negligible mass all the time moves along a straight line orthogonal to the plane of the massive bodies. This problem was suggested by Kolmogorov for verification of possibility of combinations of the final motions of three bodies according to Chazy’s classification (see § 7.3).

The dynamics of the speck of dust is described by a non-autonomous Hamiltonian system of the form (9.35) with a periodic Hamiltonian. The extended phase space is the direct product

$$\mathbb{T} \times \mathbb{R}^2 = \{x \bmod 2\pi, y, z\}.$$

Of course, this system has the Poincaré–Cartan invariant (9.38).

Kolmogorov’s problem is non-integrable: it does not admit non-constant analytic integrals. The reason is the quasi-random character of the behaviour of its trajectories. In particular, there are infinitely many non-degenerate long-periodic trajectories. As shown in [336], this implies the absence of non-trivial analytic symmetry fields: $u = cv$, $c = \text{const}$. Applying Theorem 9.5 we obtain that the equations of this problem do not admit new conditional integral invariants. One can prove in similar fashion that there are no new analytic

invariants on fixed energy manifolds with large negative energy in the planar circular restricted three-body problem. The requisite preparatory results on the structure of the set of long-periodic non-degenerate trajectories were established in [394] by the methods of symbolic dynamics.

These results prove Poincaré’s conjecture on the absence of new integral invariants for several variants of the restricted three-body problem.

9.5 Integral Invariants of the Second Order and Multivalued Integrals

Using the same methods one can study the question about conditional invariants of the second order

$$\int_D \Phi, \tag{9.54}$$

where D is a two-dimensional cycle in M^3 and Φ is a 2-form. The conditions for the invariance of the integral (9.54) have the form

$$L_v \Phi = \Psi, \quad d\Psi = 0. \tag{9.55}$$

For relative invariants, the 2-form Ψ is exact, and for absolute invariants, $\Psi = 0$.

Since the invariant volume 3-form Ω is non-degenerate, we have

$$d\Phi = f\Omega, \quad f: M^3 \rightarrow \mathbb{R}. \tag{9.56}$$

Proposition 9.5. *The function f is an integral of system (9.1) on M^3 .*

◁ Indeed, applying (9.53) and (9.54) we obtain

$$0 = d\Psi - dL_v \Phi = L_v d\Phi = L_v(f\Omega) = (L_v f)\Omega + fL_v \Omega = \dot{f}\Omega.$$

Consequently, $\dot{f} = 0$, as required. ▷

By Lemma 9.4 system (9.1) has the absolute invariant $i_v \Omega$, so that the question can be about the existence of yet another integral invariant.

For what follows it is useful to introduce the notion of *multivalued integral* of system (9.1). This is a closed 1-form ϑ such that

$$i_v \vartheta = 0. \tag{9.57}$$

Locally, $\vartheta = dg$ and

$$\dot{g} = i_v dg = 0$$

according to (9.57). Thus, locally the function g is an ordinary integral of system (9.1). If

$$H^1(M, \mathbb{R}) = 0, \tag{9.58}$$

then the function g is defined globally, and the multivalued integral becomes an ordinary integral of system (9.1). Since $\dim M = 3$, conditions (9.50) and (9.58) are equivalent by the Poincaré duality theorem.

Throughout what follows, the objects (M, v, Ω, Φ) under consideration are assumed to be analytic.

Theorem 9.7 ([131]). *Suppose that M^3 is compact and system (9.1) admits a conditional integral invariant (9.54) such that*

$$\Phi \neq ci_v\Omega, \quad c = \text{const.} \quad (9.59)$$

Then system (9.1) has a non-trivial multivalued integral $\vartheta \neq 0$.

◁ According to Proposition 9.5 the function f in equality (9.56) is an integral of system (9.1). If $f \neq \text{const}$, then Theorem 9.7 is proved. Suppose that $f = \alpha = \text{const}$. Integrating both parts of the equality

$$d\Phi = \alpha\Omega \quad (9.60)$$

over the compact manifold M and applying Stokes' theorem we obtain

$$\alpha \int_M \Omega = 0.$$

Since the 3-form Ω is a volume form, we have $\alpha = 0$. Consequently, by (9.59) the form Φ is closed.

We set (according to Lemma 9.5)

$$\Phi = i_u\Omega.$$

Since the 2-form Φ is closed, by Theorem 9.5 the field u commutes with the field v . There are two possible cases:

- 1) the vectors $u(x)$ and $v(x)$ are linearly dependent at every point $x \in M$,
- 2) these vectors are almost everywhere independent.

Since $v \neq 0$, in the first case

$$u(x) = \lambda(x)v(x), \quad \lambda: M \rightarrow \mathbb{R}.$$

Since u is a symmetry field, λ is an integral of system (9.1). If $\lambda \neq \text{const}$, then the theorem is proved. The case $\lambda = \text{const}$ is impossible in view of condition (9.59).

In the second case, it is easy to verify that the differential 1-form

$$i_v i_u \Omega = \varphi$$

is closed. It is obvious that φ is a multivalued integral. ▷

Corollary 9.3. *Under the assumptions of Theorem 9.7, equation (9.1) can be explicitly integrated by using finitely many algebraic operations, differentiations, and quadratures.*

Additional differentiations are needed for finding a multivalued integral.

Remark 9.5. Theorem 9.7 is also valid in the case where there is a linear integral invariant

$$\oint \varphi.$$

It is only required that the 2-form $\Phi = d\varphi$ satisfy condition (9.59).

Since the differential equations of the various variants of the three-body problem considered above do not admit non-trivial symmetry fields or multi-valued integrals, any conditional integral invariant of these equations of the form (9.54) may differ only by a constant factor from the invariant

$$\int_D dz \wedge dy - dH \wedge dx.$$

Since $\dim M = 3$, it makes sense to consider only absolute integral invariants of the third order. The corresponding 3-form has the form $f\Omega$ and by Lemma 9.3 the function f is an integral of equations (9.1). For the equations of dynamics considered above, $f = \text{const}$.

Integral invariants of dynamical systems on three-dimensional manifolds with positive entropy were described in [582].

The problem of conditions for the existence of integral invariants of Hamiltonian systems with many degrees of freedom requires additional consideration.

9.6 Tensor Invariants of Quasi-Homogeneous Systems

9.6.1 Kovalevskaya–Lyapunov Method

It turns out that the existence of tensor invariants is closely related to the branching properties of solutions of differential equations in the plane of complex time. The case of first integrals was considered in § 7.5.

We consider these questions from a more general viewpoint by means of the example of the systems of differential equations

$$\dot{z}_i = v_i(z_1, \dots, z_n), \quad 1 \leq i \leq n, \tag{9.61}$$

that are invariant under the similarity transformations

$$t \mapsto \frac{t}{\alpha}, \quad z_1 \mapsto \alpha^{g_1} z_1, \quad \dots, \quad z_n \mapsto \alpha^{g_n} z_n$$

with positive integers g_j . The criterion for the invariance of equations (9.61) is the validity of the relations

$$v_i(\alpha^{g_1} z_1, \dots, \alpha^{g_n} z_n) = \alpha^{g_i+1} v_i(z_1, \dots, z_n).$$

Such systems are usually called *quasi-homogeneous systems*, and the numbers g_1, \dots, g_n the *quasi-homogeneity exponents*. Quasi-homogeneous systems often occur in applications. An example is provided by the Euler–Poincaré equations on Lie algebras with quadratic right-hand sides: here one can take $g_1 = \dots = g_n = 1$. Somewhat more complicated examples are the *Euler–Poisson equations* describing the rotation of a heavy rigid body around a fixed point, as well as the equations of the problem of n gravitating bodies.

It turns out that for quasi-homogeneous systems the problem of conditions for single-valuedness of solutions in the plane of complex time can practically be completely solved. Here we reproduce the analysis of equations (9.61) carried out by Yoshida [616] according to Kovalevskaya’s method. We remind the reader of the celebrated result of Kovalevskaya: the general solution of the Euler–Poisson differential equations can be represented by meromorphic functions of time t only in those cases where there is an additional first integral. It is in this way that she arrived at discovering the new integrable case, which now bears her name.

First we observe that system (9.61) admits the particular meromorphic solutions

$$z_1 = \frac{c_1}{t^{g_1}}, \quad \dots, \quad z_n = \frac{c_n}{t^{g_n}},$$

where the constants c_1, \dots, c_n satisfy the algebraic system of equations

$$v_i(c_1, \dots, c_n) = -g_i c_i, \quad 1 \leq i \leq n.$$

As a rule, these equations have non-zero complex roots.

We seek the general solution of equations (9.61) in the form

$$z_i = (c_i + x_i)^{-g_i}. \tag{9.62}$$

One can show that the functions $t \mapsto x(t)$ satisfy the following system of differential equations:

$$t\dot{x}_i = \sum_{j=1}^n K_{ij} x_j + \sum_{|m|=2}^{\infty} K_{m_1, \dots, m_n}^{(i)} x^{m_1} \dots x^{m_n}, \tag{9.63}$$

$$K_{ij} = \frac{\partial v_i}{\partial z_j}(c) + g_i \delta_{ij}, \quad K_{m_1 \dots m_n}^{(i)} = \frac{\partial^{m_1 + \dots + m_n} v_i}{\partial^{m_1} z_1 \dots \partial^{m_n} z_n}(c),$$

where δ_{ij} is the Kronecker delta. The matrix $K = (K_{ij})$ is called the *Kovalevskaya matrix*, and its eigenvalues ρ_1, \dots, ρ_n the *Kovalevskaya exponents*.

Proposition 9.6. *If $c \neq 0$, then $\rho = -1$ is a Kovalevskaya exponent.*

Indeed, the non-zero vector $v(c)$ is an eigenvector of the matrix K with eigenvalue -1 . For definiteness, we set $\rho_1 = -1$.

Theorem 9.8 (Lyapunov). *If all the solutions of system (9.61) are single-valued functions of complex time, then*

- 1) *the Kovalevskaya exponents are integers,*
- 2) *the Kovalevskaya matrix can be reduced to the diagonal form*
 $\text{diag}(\rho_1, \dots, \rho_n)$.

◁ The proof is based on analysing the variational equations

$$t\dot{x} = Kx,$$

which are *Fuchs equations*. These equations have the particular solutions

$$t^{\rho_i} \xi_i, \quad \xi_i \in \mathbb{C}^n, \tag{9.64}$$

where the ξ_i are eigenvectors of the matrix K corresponding to the eigenvalues ρ_i . If the ρ_i are not integers, then the solutions (9.64) (and therefore the functions (9.62)) branch when going around the point $t = 0$. It turns out that the branching property remains valid also for the solutions of the full system (9.63). ▷

Kovalevskaya solved the problem of conditions for the general solution of system (9.61) to be meromorphic. A necessary condition is that the Laurent series of the solutions of (9.61) contain $n - 1$ arbitrary constants. One more parameter appears when t is replaced by $t + \beta$, $\beta = \text{const}$ (because the system is autonomous). A necessary condition for the solutions (9.62) to be meromorphic is that ρ_2, \dots, ρ_n be non-negative integers.

9.6.2 Conditions for the Existence of Tensor Invariants

A function $z \mapsto f(z)$ is said to be *quasi-homogeneous* of degree m if

$$f(\alpha^{g_1} z_1, \dots, \alpha^{g_n} z_n) = \alpha^m f(z_1, \dots, z_n).$$

Any analytic function f can be expanded in a series in quasi-homogeneous forms:

$$f(z) = \sum_{m \geq 0} f_m(z), \quad \text{deg } f_m = m.$$

It is clear that the quasi-homogeneous forms of the expansion of an integral of system (9.61) are themselves first integrals.

Theorem 9.9 ([616]). *Let f be a quasi-homogeneous integral of degree m of system (9.61), and suppose that $df(c) \neq 0$. Then $\rho = m$ is a Kovalevskaya exponent.*

This result establishes a remarkable connection between the property of the general solution being meromorphic and the existence of non-constant integrals.

Now suppose that system (9.61) admits an absolute integral invariant generated by a k -form

$$\omega = \sum_{i_1 < \dots < i_k} \omega_{i_1 \dots i_k}(z) dz_{i_1} \wedge \dots \wedge dz_{i_k}.$$

This form can also be expanded in a series in quasi-homogeneous forms. The form ω is said to be *quasi-homogeneous* of degree m if

$$\omega_{i_1 \dots i_k}(\alpha^{g_1} z_1, \dots, \alpha^{g_n} z_n) = \alpha^j \omega_{i_1 \dots i_k}(z), \quad j = m - g_{i_1} - \dots - g_{i_k}. \quad (9.65)$$

Theorem 9.10 ([339]). *Suppose that a quasi-homogeneous k -form ω of degree m generates an absolute invariant of system (9.61), and $\omega \neq 0$ at the point $z = c$. Then for some indices i_1, \dots, i_k the Kovalevskaya exponents satisfy the relation*

$$\rho_{i_1} + \dots + \rho_{i_k} = m. \quad (9.66)$$

Theorem 9.10 is a far-reaching generalization of Theorem 9.9. Indeed, if f is a quasi-homogeneous integral of degree m of system (9.61), then $\omega = df$ is an invariant quasi-homogeneous form of degree m . If $z = c$ is not a critical point of the function f , then $\omega \neq 0$ at this point. Since ω is a 1-form, relation (9.66) gives us that $\rho_i = m$ for some i .

In particular, if ω is a quasi-homogeneous volume form of degree m , then Theorem 9.10 gives the following relation for the Kovalevskaya exponents:

$$\rho_1 + \dots + \rho_n = m. \quad (9.67)$$

For example, the Euler–Poincaré equations on an n -dimensional unimodular Lie algebra admit the standard invariant measure generated by the volume n -form $dz_1 \wedge \dots \wedge dz_n$. According to (9.65), this form is quasi-homogeneous of degree n ($j = 0$) with quasi-homogeneity exponents $g_1 = \dots = g_n = 1$. Consequently, it follows from (9.67) that in this case the sum of all Kovalevskaya exponents is equal to n .

Example 9.1. Consider the Euler top described by the differential equations in \mathbb{R}^3

$$I\dot{\omega} = I\omega \times \omega. \quad (9.68)$$

Here ω is the vector of angular velocity, and I is the inertia tensor. Equations (9.68) are the Euler–Poincaré equations on the algebra $so(3)$. For equations (9.68) there are non-trivial solutions of the algebraic system

$$(I\mathbf{c}) \times \mathbf{c} = -I\mathbf{c}, \quad \mathbf{c} \neq 0.$$

In addition, these equations admit the two quadratic integrals

$$(I\omega, \omega), \quad (I\omega, I\omega),$$

whose differentials are linearly independent at the point $\omega = \mathbf{c}$ if the inertia tensor I is not spherical. Consequently, $\rho = 2$ is a Kovalevskaya exponent of multiplicity two by Theorem 9.9. Thus, the Kovalevskaya exponents are the numbers $-1, 2, 2$, the sum of which is equal to $\dim so(3) = 3$. \triangle

In [339] a more general problem was actually considered, that of the existence of tensor invariants of equations (9.59), that is, tensor fields of the form

$$T_{j_1 \dots j_q}^{i_1 \dots i_p}(z)$$

that are invariant under the action of the phase flow of system (9.61). For example, to $(1, 0)$ -tensors there correspond symmetry fields. In [339] it was proved that the existence of tensor invariants implies *resonance* relations for the Kovalevskaya exponents, which generalize equalities (9.66):

$$\rho_{i_1} + \dots + \rho_{i_p} - \rho_{j_1} - \dots - \rho_{j_q} + m = 0.$$

In particular, if there is a non-trivial symmetry field of quasi-homogeneity degree m , then $\rho = -m$ is a Kovalevskaya exponents. Since the field v itself is a symmetry field of quasi-homogeneity degree $m = 1$, we arrive at the conclusion of Proposition 9.6.

9.7 General Vortex Theory

9.7.1 Lamb's Equation

Examples usually used to illustrate the theory of integral invariants are Hamiltonian systems, dynamics of ideal fluid, and geometrical optics (see for example, [18]). It turns out that these three seemingly different theories are underlied by one general mathematical construction, in which integral invariants play a central role.

It is well known that the equations of motion of an ideal fluid (equations (9.41) for $\nu = 0$) can be represented in the form

$$\frac{\partial \mathbf{v}}{\partial t} + (\text{curl } \mathbf{v}) \times \mathbf{v} = -\frac{\partial f}{\partial x}, \tag{9.69}$$

where $f = v^2/2 + P + V$ and P is the pressure function (for homogeneous fluid, $P = p/\rho$). Equation (9.69) is called *Lamb's equation*.

We now consider propagation of light in a non-homogeneous isotropic medium with refraction index $n(x)$, $x \in \mathbb{R}^3$: the light particles move along rays with speed equal to $1/n$. In construction of optical images an essential role is played not by particular rays, but rather by *systems of rays* – families of light rays singly filling space: a unique ray passes through each point x , and the direction of the ray smoothly depends on the point x . Thus, a system of

rays is in a one-to-one correspondence with the field of velocities $\mathbf{v}(x)$ of light particles. One can show that this field satisfies the equation

$$(\operatorname{curl} n^2 \mathbf{v}) \times \mathbf{v} = 0. \quad (9.70)$$

For a homogeneous medium, where $n = \text{const}$, equation (9.70) coincides with the equation of a stationary flow of fluid, where the field of velocities is collinear with its curl. An example is provided by the well-known *ABC*-flow of Arnold–Beltrami–Childress: the components of the velocity field have the form

$$A \sin x_3 + C \cos x_2, \quad B \sin x_1 + A \cos x_3, \quad C \sin x_2 + B \cos x_1.$$

Here, $\operatorname{curl} \mathbf{v} = \mathbf{v}$. Since the field is 2π -periodic in the coordinates x_1, x_2, x_3 , it can be considered on a three-dimensional torus. For almost all values of A, B, C , on the torus there are domains with chaotic behaviour of trajectories.

It is easy to find condition under which a system of rays is orthogonal to some family of surfaces in \mathbb{R}^3 :

$$\langle \mathbf{v}, \operatorname{curl} n^2 \mathbf{v} \rangle = 0.$$

Comparing this with (9.70) we obtain that then $\operatorname{curl} n^2 \mathbf{v} = 0$. Consequently,

$$n^2 \mathbf{v} = \frac{\partial \varphi}{\partial x}, \quad \varphi: \mathbb{R}^3 \rightarrow \mathbb{R}.$$

Such systems of rays are called *Hamiltonian systems*. A classical result is *Malus' theorem*: if a system of rays is orthogonal to some regular surface, then this system is Hamiltonian and remains to be such after any number of reflections and refractions. Malus' theorem can be easily proved by applying the linear integral invariant

$$\oint n^2 \langle \mathbf{v}, dx \rangle.$$

Systems of rays for which $\operatorname{curl} n^2 \mathbf{v} \neq 0$ are called *Kummer systems*. They are less studied in comparison with Hamiltonian systems of rays.

We now consider the canonical Hamilton equations (9.14) with Hamiltonian $H(x, y, t)$ which may explicitly depend on time. Suppose that these equations have an n -dimensional invariant manifold given by equations

$$y = u(x, t), \quad (9.71)$$

where u is a smooth covector field on the configuration manifold N^n .

We introduce a vector field of velocities v on N by setting

$$v(x, t) = \dot{x} = \left. \frac{\partial H}{\partial y} \right|_{y=u},$$

and the function $h(x, t) = H(x, u(x, t), t)$. It turns out that the fields u , v and the function h are connected by the relation

$$\frac{\partial u}{\partial t} + (\text{curl } u) v = -\frac{\partial h}{\partial x}, \quad (9.72)$$

where

$$\text{curl } u = \left(\frac{\partial u_i}{\partial x_j} - \frac{\partial u_j}{\partial x_i} \right)$$

is a skew-symmetric $n \times n$ -matrix (the curl of the covector field u). For $n = 3$ the value $(\text{curl } u) v$ coincides with the ordinary vector product $(\text{curl } u) \times v$.

The form of equation (9.72) coincides with that of (9.69); we also call (9.72) *Lamb's equation*. The similarity of the forms of equations (9.69), (9.70), and (9.72) gives an opportunity to develop an analogy between hydrodynamics, geometrical optics, and Hamiltonian mechanics. The existence of the invariant relations (9.71) allows us to reduce Hamilton's equations (9.14) in the $2n$ -dimensional phase space to the system of differential equations

$$\dot{x} = v(x, t) \quad (9.73)$$

on the n -dimensional configuration space. System (9.73) possesses many of the properties characteristic of flows of an ideal fluid [330].

9.7.2 Multidimensional Hydrodynamics

We set $\omega = \sum u_i dx_i$ and $\Omega = d\omega$. Then system (9.73) can be rewritten in the following equivalent form:

$$\frac{\partial \omega}{\partial t} + i_v \Omega = -dh.$$

System (9.71) admits the relative integral invariant

$$\oint \omega.$$

This is an analogue of *Thomson's theorem* on the conservation of circulation.

We call a field u conservative if $\text{curl } u = 0$; locally, $u = \partial\varphi/\partial x$. *Lagrange's theorem* holds: if a field u is conservative at $t = 0$, then it is conservative at all t . This is a simple consequence of Thomson's theorem. Substituting $u = \partial\varphi/\partial x$ into equation (9.72) we obtain

$$\frac{\partial \varphi}{\partial t} + H \left(x, \frac{\partial \varphi}{\partial x}, t \right) = f, \quad (9.74)$$

where f is some function of t . In hydrodynamics, relation (9.74) is called the *Lagrange-Cauchy integral*, and in Hamiltonian mechanics it is called the *Hamilton-Jacobi equation*. After gauging the potential

$$\varphi \mapsto \varphi - \int f(t) dt,$$

the function f on the right-hand side of (9.74) can be made to be equal to zero.

In hydrodynamics, non-zero vectors w satisfying the equality $(\text{curl } u) \cdot w = 0$ (or $i_w \Omega = 0$) are called *vortex vectors*. The distribution of vortex vectors is integrable: through each point $x \in N$ there passes a unique maximal integral manifold of this distribution, which is tangent to all the vortex vectors at each of its points. It is natural to call such manifolds *vortex manifolds*. In Cartan’s terminology, these are characteristic manifolds of the 2-form Ω . We emphasize that vortex manifolds are defined for a fixed value of t .

The following analogue of the *Helmholtz–Thomson theorem* holds: the phase flow of system (9.73) takes vortex manifolds to vortex manifolds. In the stationary case (where the fields u, v and the function h do not explicitly depend on t) the function h is constant on the flow lines (the integral curves of the field v) and on vortex manifolds. This is a generalization of the celebrated *Bernoulli theorem*.

The differential 1-form ω locally can be reduced to the form

$$\omega = dS + x_1 dx_2 + \dots + x_{2k-1} dx_{2k}, \tag{9.75}$$

where S is some smooth function of x and t , and $2k$ is the rank of the 2-form $\Omega = d\omega$. We write down in an explicit form the components of the covector field u :

$$u_1 = \frac{\partial S}{\partial x_1}, \quad u_2 = \frac{\partial S}{\partial x_2} + x_1, \quad \dots, \quad u_{2k+1} = \frac{\partial S}{\partial x_{2k+1}}, \quad \dots, \quad u_n = \frac{\partial S}{\partial x_n},$$

and Lamb’s equation (9.72):

$$\begin{aligned} \dot{x}_1 &= -\frac{\partial}{\partial x_2} \left(\frac{\partial S}{\partial t} + h \right), & \dot{x}_2 &= \frac{\partial}{\partial x_1} \left(\frac{\partial S}{\partial t} + h \right), \\ \dots & & \dots & \\ \dot{x}_{2k-1} &= -\frac{\partial}{\partial x_{2k}} \left(\frac{\partial S}{\partial t} + h \right), & \dot{x}_{2k} &= \frac{\partial}{\partial x_{2k-1}} \left(\frac{\partial S}{\partial t} + h \right), \end{aligned} \tag{9.76}$$

$$\frac{\partial}{\partial x_{2k+1}} \left(\frac{\partial S}{\partial t} + h \right) = \dots = \frac{\partial}{\partial x_n} \left(\frac{\partial S}{\partial t} + h \right) = 0. \tag{9.77}$$

It follows from (9.77) that $\partial S/\partial t + h$ is a function only of the coordinates x_1, \dots, x_{2k} and time t . These relations generalize the Hamilton–Jacobi equation and coincide with it for $k = 0$, when the field u is conservative. Then the function S plays the role of the action according to Hamilton.

Thus, (9.76) is a closed system of canonical Hamilton’s equations with the Hamiltonian $\partial S/\partial t + h$.

According to (9.75), in these variables we have

$$\Omega = dx_1 \wedge dx_2 + \dots + dx_{2k-1} \wedge dx_{2k},$$

and therefore the vortex manifolds (the characteristic $(n - 2k)$ -dimensional surfaces) are given by the equations

$$x_1 = \alpha_1, \dots, x_{2k} = \alpha_{2k}, \quad \alpha = \text{const.}$$

Since the derivatives $\dot{x}_1, \dots, \dot{x}_{2k}$ depend only on x_1, \dots, x_{2k}, t , this immediately implies the Helmholtz–Thomson theorem saying that the vortex manifolds are frozen into the flow of system (9.73).

In hydrodynamics the variables x_1, \dots, x_{2k} and the function S are called *Clebsch potentials*. Back in 1857 Clebsch represented the 1-form of velocity circulation $v_1 dx_1 + v_2 dx_2 + v_3 dx_3$ in the form (9.75). For $n = 3$ equations (9.76) and (9.77) were obtained by Clebsch and Stewart (see, for example, [366]).

9.7.3 Invariant Volume Forms for Lamb’s Equations

In hydrodynamics, equation (9.69) is supplemented by the *continuity equation*

$$\frac{\partial \rho}{\partial t} + \text{div}(\rho \mathbf{v}) = 0, \tag{9.78}$$

which is equivalent to the existence of the integral invariant

$$\int \rho d^3x$$

of the mass of moving volume. The question arises: does system (9.73) admit similar invariants in the general case?

In this problem an essential role is played by the notion of *class* of a differential form, which was introduced by Cartan. Recall that the class of a differential form α at a point $x \in M$ is by definition the codimension of the vector subspace of vectors $\xi \in T_x M$ such that

$$i_\xi \alpha = i_\xi d\alpha = 0.$$

We shall consider forms of *constant class*, when the class of a form is independent of the point x . Note that the class of a closed 2-form is always an even integer.

Proposition 9.7. *Let $n = 2s$ be even and suppose that the class of the 2-form $\Omega = d\omega$ is equal to n . Then system (9.73) admits the integral invariant*

$$\int \tau, \quad \tau = \Omega^s. \tag{9.79}$$

By the way, this assertion contains as a special case Liouville’s theorem on the conservation of phase volume in Hamiltonian systems.

Now suppose that $n = 2s + 1$ is odd and the class of the 1-form ω is equal to n . Then the n -form $\tau = \omega \wedge \Omega^s$ is a volume form on M ; but this form is not

invariant in the general case. Indeed, one can obtain the following expression for the derivative of τ with respect to time:

$$\dot{\tau} = dg \wedge \Omega^s,$$

where $g = i_v\omega - h$ is the *Lagrangian* of the problem considered. Since the form Ω is closed, we have

$$dg \wedge \Omega^s = d(g\Omega^s).$$

Hence for a compact M we have

$$\frac{d}{dt} \int_M \tau = \int_M dg \wedge \Omega^s = \int_M d(g\Omega^s) = 0.$$

Thus, the τ -volume of the whole of M is conserved. However, this remark is non-trivial only for non-autonomous systems.

We now consider the important special case where equations (9.72) are Lamb's equations for a stationary n -dimensional invariant surface of a Hamiltonian system with Hamiltonian that is quadratic in the momenta (this case corresponds to free motion).

Proposition 9.8 ([337]). *In the case under consideration, where the form ω has odd class $n = 2s + 1$, system (9.73) admits the integral invariant (9.79), where $\tau = \omega \wedge \Omega^s$.*

If the class of the forms ω and Ω is not maximal, then it is altogether impossible to use them for producing a volume form. Thus, the question of the existence of invariant measures of equations (9.73) is a non-trivial problem.

The most general approach is to seek a *complete solution* $u(x, t, c)$, $c = (c_1, \dots, c_n)$, of Lamb's equations that satisfies the non-degeneracy condition

$$\rho = \frac{\partial(u_1, \dots, u_n)}{\partial(c_1, \dots, c_n)} \neq 0. \tag{9.80}$$

For conservative solutions $u = \partial\varphi/\partial x$ a complete solution of Lamb's equation becomes a *complete integral* $\varphi(t, x, c)$ of the Hamilton–Jacobi equation (9.74). In this case condition (9.80) takes the well-known form

$$\det \left(\frac{\partial^2 \varphi}{\partial x_i \partial c_j} \right) \neq 0.$$

Proposition 9.9. *For fixed values of c the function (9.80) satisfies the continuity equation (9.78), where $\operatorname{div} = \sum \partial/\partial x_i$.*

Thus, system (9.73) admits the integral invariant

$$\int \rho \, d^n x.$$

Proposition 9.9 is derived from Liouville’s theorem on the conservation of phase volume of Hamiltonian systems.

In conclusion we consider the question of the existence of an invariant measure of equations (9.73) in the problem of geodesic lines of left-invariant metrics on Lie groups. Let G be a Lie group, g its Lie algebra, and let T be a left-invariant metric on G – the kinetic energy of a mechanical system with configuration space G . If $\omega = (\omega_1, \dots, \omega_n) \in g$ is the velocity of the system, then

$$T = \frac{1}{2} \sum I_{ij} \omega_i \omega_j. \tag{9.81}$$

In view of the assumption that T is left-invariant, $I_{ij} = \text{const}$. The symmetric positive-definite matrix $I = (I_{ij})$ is the inertia tensor of the system. The theorem on variation of the momentum gives rise to the Euler–Poincaré equations on the algebra g , which should be supplemented by the n ($= \dim G$) kinematic relations

$$\dot{x}_i = \sum_j v_i^j \omega_j, \tag{9.82}$$

where x_1, \dots, x_n are local coordinates on the group G and the

$$v_j = (v_1^j, \dots, v_n^j)$$

are left-invariant fields on G satisfying the commutation relations

$$[v_i, v_j] = \sum_k c_{ij}^k v_k.$$

Let w_1, \dots, w_n be right-invariant fields on the group G . Their phase flows are families of left translations. Since the Lagrangian T is left-invariant, the equations of motion on TG admit the n independent *Nötherian integrals*

$$\frac{\partial T}{\partial \dot{x}} \cdot w_i = c_i, \quad 1 \leq i \leq n. \tag{9.83}$$

In view of (9.81) and (9.82) the left-hand sides of these equations are linear in ω . From (9.83) the velocities ω can be represented as single-valued functions on the group G (for fixed values of c_1, \dots, c_n). As a result we obtain autonomous equations on the group G of the form (9.73):

$$\dot{x}_i = \sum_j v_i^j(x) \omega_j(x, c). \tag{9.84}$$

Theorem 9.11 ([358]). *If the group G is unimodular (that is, the structure constants of its Lie algebra satisfy $\sum c_{ik}^k = 0$ for all $1 \leq i \leq n$), then for all values of c the phase flow of system (9.84) preserves the Haar measure on G .*

Recall that on each group there is a unique (up to a constant factor) measure that is invariant under all left (right) translations. In the case of an

unimodular group this measure (called a Haar measure) is bi-invariant. In particular, all compact groups are unimodular.

Theorem 9.11 is proved by using Proposition 9.9. This theorem is a consequence of a more general result: the phase flow of system (9.84) preserves a right-invariant measure on G .

A systematic exposition of the questions considered here can be found in the book [31]. Topological methods in dynamics of viscous fluid (including multidimensional one) are expounded in the book [13].

Comments on the Bibliography

The basic principles of mechanics are sufficiently completely and comprehensively expounded in the books [1, 5, 10, 49]. One can learn about the genesis of the basic concepts of mechanics in the book [32]. The book [22] contains an unusual construction of dynamics, in which there is no notion of accelerating force: the bending of trajectories is only caused by constraints imposed on the system. The collection of papers [42] gives a good representation of the development of variational methods of classical mechanics up to 1950. In the book [18] a systematic approach to Hamiltonian mechanics is developed based on the use of integral invariants. The paper [21] contains a construction of the theory of Hamiltonian systems with constraints.

The works [41, 14] had a decisive influence on the modern development of the theory of differential equations and classical mechanics. Therein new concepts and methods were introduced, which have now become classical. The works [2, 4, 9, 26, 27, 37, 41, 47] are devoted to qualitative aspects of the theory of dynamical systems.

The mathematical aspects of celestial mechanics are discussed in the books [20, 41, 46, 52]. In [46, 52] problems of celestial mechanics are treated as problems of the qualitative and analytic theory of differential equations, while the book [20] contains a thorough introduction to perturbation theory. The paper [3] is a survey of the results devoted to the qualitative analysis of final motions in the three-body problem (see also [37]).

The problems of reduction of order of Hamiltonian systems are discussed in detail in [18, 41] (see also [411]). Concerning the order reduction in the sense of Routh for Lagrangian systems see [312, 580]. The paper [47] contains a detailed study of the energy–momentum map.

Various questions of the theory of integrable systems are discussed in [10, 19, 23, 28, 36, 38, 57, 58, 216]. In [19, 23, 36] the analytical aspects are emphasized, while in [38, 57, 58, 216, 440] the modern algebro-geometric methods of integration of Hamiltonian systems are discussed.

Perturbation theory for systems of differential equations of general form is discussed in [9, 15, 16, 34, 35], and for Hamiltonian systems, in [20, 40, 41].

KAM theory was initiated by Kolmogorov's work [25]. The papers [6, 7] contain the first detailed proofs of the theorems on conservation of the invariant tori of Hamiltonian systems. The theory of perturbations of conditionally periodic solutions of non-Hamiltonian systems of differential equations was developed in [35].

In [28] methods for proving non-integrability of Hamiltonian systems are expounded. The papers [44, 45] contain detailed proofs of non-integrability of Hamilton's equations near equilibrium positions. Problems concerning the qualitative analysis of the behaviour of trajectories in non-integrable dynamical systems are considered in [2, 4, 37, 41].

A survey of results in the theory of stability of equilibria and stationary motions of mechanical systems is contained in [24]. The elements of oscillation theory are expounded in [9, 10, 49]. The papers [50, 51] contain a complete description of normal forms of linear Hamiltonian systems.

Recommended Reading

1. Abraham, R., Marsden, J.E.: *Foundations of Mechanics*. Benjamin/Cummings, Reading, MA (1978), 806 pp.
2. Alekseev, V.M.: Quasirandom dynamical systems. I: Quasirandom diffeomorphisms; II: One-dimensional nonlinear oscillations in a field with periodic perturbation; III: Quasirandom oscillations of one-dimensional oscillators. *Mat. Sb.* 76, 72–134 (1968); 77, 545–601 (1968); 78, 3–50 (1969). Engl. transl.: *Math. USSR, Sb.* 5, 73–128 (1968); 6, 505–560 (1968); 7, 1–43 (1969)
3. Alekseev, V.M.: Final motions in the three-body problem and symbolic dynamics. *Usp. Mat. Nauk* 36, No. 4, 161–176 (1981). Engl. transl.: *Russ. Math. Surv.* 36, No. 4, 181–200 (1981)
4. Anosov, D.V.: Geodesic flows on closed Riemannian manifolds with negative curvature. *Tr. Mat. Inst. Steklova* 90 (1967), 209 pp. Engl. transl.: *Proc. Steklov Inst. Math.* 90 (1967), 235 pp.
5. Appell, P.: *Traité de Mécanique Rationnelle*. T. 1, 2. Gauthier-Villars, Paris (1919, 1924), 619 pp., 575 pp.
6. Arnol'd, V.I.: Proof of a theorem of A.N. Kolmogorov on the invariance of quasi-periodic motions under small perturbations of the Hamiltonian. *Usp. Mat. Nauk* 18, No. 5, 13–40 (1963). Engl. transl.: *Russ. Math. Surv.* 18, No. 5, 9–36 (1963)
7. Arnol'd, V.I.: Small denominators and problems of stability of motion in classical and celestial mechanics. *Usp. Mat. Nauk* 18, No. 6, 91–192 (1963). Engl. transl.: *Russ. Math. Surv.* 18, No. 6, 85–191 (1963)
8. Arnol'd, V.I.: Instability of dynamical systems with several degrees of freedom. *Dokl. Akad. Nauk SSSR* 156, 9–12 (1964). Engl. transl.: *Sov. Math., Dokl.* 5, 581–585 (1964)
9. Arnol'd, V.I.: *Supplementary Chapters to the Theory of Ordinary Differential Equations*. Nauka, Moscow (1978), 304 pp.; 2nd ed.: *Geometric Methods in the Theory of Ordinary Differential Equations*. Research Centre “Regular and chaotic dynamics”, Izhevsk (2000), 400 pp. Engl. transl.: *Geometrical Methods in the Theory of Ordinary Differential Equations*. Grundlehren der Mathematischen Wissenschaften 250. Springer-Verlag, New York etc. (1988), 351 pp.
10. Arnol'd, V.I.: *Mathematical Methods of Classical Mechanics*. Nauka, Moscow (1974) 432 pp.; 4th ed.: Editorial URSS, Moscow (1999), 408 pp. Engl. transl. of

- 1st ed.: Graduate Texts in Mathematics 60, Springer-Verlag, New York (1978), 462 pp.
11. Arnol'd, V. I., Givental', A. B.: Dynamical systems. IV: Symplectic geometry. In: *Itogi Nauki Tekh.*, Ser. *Sovrem. Probl. Mat.*, Fundam. *Napravleniya* 4 (1985), 7–139; 2nd ed.: Udmurt Univ., Izhevsk (2000), 168 pp. Engl. transl.: Dynamical systems. IV. Symplectic geometry and its applications. *Encycl. Math. Sci.* 4. Springer-Verlag, Berlin (1990), 1–136.
 12. Arnol'd, V. I., Il'yashenko, Yu. S.: Dynamical systems. I: Ordinary differential equations. In: *Itogi Nauki Tekh.*, Ser. *Sovrem. Probl. Mat.*, Fundam. *Napravleniya* 1, 7–149 (1985). Engl. transl.: Dynamical systems I, *Encycl. Math. Sci.* 1. Springer-Verlag, Berlin (1988), 1–148
 13. Arnol'd, V. I., Khesin, B. A.: *Topological Methods in Hydrodynamics*. Applied Mathematical Sciences 125. Springer-Verlag, New York (1998), 374 pp.
 14. Birkhoff, G. D.: *Dynamical Systems*. Amer. Math. Soc. Colloq. Publ. 9. American Mathematical Society, New York (1927), 295 pp. Reprint with an addendum by Jurgen Moser. American Mathematical Society, Providence R.I. (1966) 305 pp.
 15. Bogolyubov, N. N.: On Some Statistical Methods in Mathematical Physics. *Akad. Nauk USSR, L'vov* (1945), 140 pp. (Russian)
 16. Bogolyubov, N. N., Mitropol'skij, Yu. A.: *Asymptotic Methods in the Theory of Non-Linear Oscillations*. Nauka, Moscow (1974), 504 pp. Engl. transl. of 1st ed.: Hindustan Publishing Corp., Delhi; Gordon and Breach Science Publishers, New York (1961), 537 pp.
 17. Broer, H. W., Huitema, G. B., Sevryuk, M. B.: *Quasi-Periodic Motions in Families of Dynamical Systems. Order amidst Chaos*. Lect. Notes Math. 1645. Springer-Verlag, Berlin (1997), 195 pp.
 18. Cartan, É.: *Leçons sur les Invariants Intégraux*. Hermann, Paris (1922), 210 pp.
 19. Chaplygin, S. A.: *Studies in Dynamics of Non-Holonomic Systems*. Gostekhizdat, Moscow–Leningrad (1949), 112 pp. (Russian)
 20. Charlier, C. L.: *Die Mechanik des Himmels*. Bd. I, II. Walter de Gruyter, Berlin (1927), 488 pp., 478 pp.
 21. Dirac, P. A. M.: Generalized Hamiltonian dynamics. *Can. J. Math.* 2, 129–148 (1950)
 22. Hertz, H.: *Gesammelte Werke*. 3. Bd.: *Die Prinzipien der Mechanik in Neuem Zusammenhange Dargestellt*. J. A. Barth, Leipzig (1910), 312 pp.
 23. Jacobi, C. G. J.: *Vorlesungen über Analytische Mechanik* Berlin 1847/48. Dokumente zur Geschichte der Mathematik 8. Vieweg, Wiesbaden (1996), 353 pp.
 24. Karapetyan, A. V., Rumyantsev, V. V.: Stability of Conservative and Dissipative Systems. *Itogi Nauki Tekh.*, Ser. *Obshch. Mekh.* 6 (1983), 132 pp. (Russian)
 25. Kolmogorov, A. N.: Preservation of conditionally periodic movements with small change in the Hamilton function. *Dokl. Akad. Nauk SSSR* 98, 527–530 (1954). Engl. transl. in: Casati, G. (ed.) et al. *Stochastic Behavior in Classical and Quantum Hamiltonian Systems*. Volta mem. Conf. (Como, Italy, 1977). *Lect. Notes Phys.* 93. Springer-Verlag, Berlin (1979), 51–56. Reprinted in: Bai Lin Hao (ed.) *Chaos*. World Scientific, Singapore (1984), 81–86
 26. Kolmogorov, A. N.: General theory of dynamical systems and classical mechanics. In: *International Mathematical Congress in Amsterdam*. Fizmatgiz, Moscow (1961), 187–208. Engl. transl. as Appendix in: Abraham, R., Marsden,

- J. E. Foundations of Mechanics. Benjamin/Cummings, Reading, MA (1978), 751–757
27. Kozlov, V. V.: Methods of Qualitative Analysis in Dynamics of a Rigid Body. Moscow Univ., Moscow (1980), 232 pp.; 2nd ed.: Research Centre “Regular and chaotic dynamics”, Izhevsk (2000), 247 pp. (Russian)
 28. Kozlov, V. V.: Integrability and non-integrability in Hamiltonian mechanics. *Usp. Mat. Nauk* 38, No. 1, 3–67 (1983). Engl. transl.: *Russ. Math. Surv.* 38, No. 1, 1–76 (1983)
 29. Kozlov, V. V.: Calculus of variations in the large and classical mechanics. *Usp. Mat. Nauk* 40, No. 2, 33–60 (1985). Engl. transl.: *Russ. Math. Surv.* 40, No. 2, 37–71 (1985)
 30. Kozlov, V. V.: Symmetries, Topology and Resonances in Hamiltonian Mechanics. Udmurt Univ., Izhevsk (1995), 429 pp. Engl. transl.: *Ergebnisse der Mathematik und ihrer Grenzgebiete. 3. Folge. 31.* Springer-Verlag, Berlin (1995), 378 pp.
 31. Kozlov, V. V.: General Vortex Theory. Research Centre “Regular and chaotic dynamics”, Izhevsk (1998), 238 pp. (Russian)
 32. Lagrange, J. L.: *Mécanique Analytique. T. 1, 2.* Gauthier-Villars et Fils., Paris (1889), 502 pp., 391 pp.
 33. Lazutkin, V. F.: KAM Theory and Semiclassical Approximations to Eigenfunctions. *Ergebnisse der Mathematik und ihrer Grenzgebiete. 3. Folge. 24.* Springer-Verlag, Berlin (1993), 387 pp.
 34. Moiseev, N. N.: Asymptotic Methods of Nonlinear Mechanics. Nauka, Moscow (1981), 400 pp. (Russian)
 35. Moser, J.: Convergent series expansions for quasi-periodic motions. *Math. Ann.* 169, 136–176 (1967)
 36. Moser, J.: Lectures on Hamiltonian Systems. *Mem. Am. Math. Soc.* 81. American Mathematical Society, Providence, R. I. (1968), 60 pp.
 37. Moser, J.: Stable and Random Motions in Dynamical Systems. With Special Emphasis on Celestial Mechanics. Hermann Weyl Lectures. The Institute for Advanced Study. *Annals of Mathematics Studies* 77. Princeton University Press and University of Tokyo Press, Princeton, N. J. (1973), 199 pp.
 38. Moser, J.: Various aspects of integrable Hamiltonian systems. In: *Dynamical Systems, C. I. M. E. Lect.*, Bressanone 1978. *Prog. Math.* 8. Birkhäuser, Boston (1980), 233–290
 39. Nejmark, Yu. I., Fufaev, N. A.: Dynamics of Nonholonomic Systems. Nauka, Moscow (1967), 519 pp. Engl. transl.: *Translations of Mathematical Monographs* 33. American Mathematical Society, Providence, R. I. (1972), 518 pp.
 40. Nekhoroshev, N. N.: An exponential estimate of the time of stability of nearly-integrable Hamiltonian systems. *Usp. Mat. Nauk* 32, No. 6, 5–66 (1977). Engl. transl.: *Russ. Math. Surv.* 32, No. 6, 1–65 (1977)
 41. Poincaré, H.: *Les Méthodes Nouvelles de la Mécanique Céleste. Tome I: Solutions Périodiques. Non-Existence des Intégrales Uniformes. Solutions Asymptotiques. Tome II: Méthodes de MM. Newcomb, Gylden, Lindstedt et Bohlin. Tome III: Invariants Intégraux. – Solutions Périodiques du Deuxième Genre. Solutions Doublement Asymptotiques.* Gauthier-Villars, Paris (1892, 1893, 1899), 385 pp., 479 pp., 414 pp. Engl. transl.: *New methods in celestial mechanics. 1. Periodic and asymptotic solutions. 2. Approximations by series. 3. Integral invariants and asymptotic properties of certain solutions.* American Institute of Physics, Bristol (1993), 1200 pp.

42. Polak L. S. (ed.): Variational Principles of Mechanics (Collection of Papers). Fizmatgiz, Moscow (1959), 932 pp. (Russian)
43. Sevryuk, M. B.: Reversible Systems. Lect. Notes Math. 1211. Subseries: USSR. Springer-Verlag, Berlin etc. (1986), 319 pp.
44. Siegel, C. L.: On the integrals of canonical systems. *Ann. Math. (2)* 42, 806–822 (1941)
45. Siegel, C. L.: Über die Existenz einer Normalform analytischer Hamiltonscher Differentialgleichungen in der Nähe einer Gleichgewichtslösung. *Math. Ann.* 128, 144–170 (1954)
46. Siegel, C. L., Moser, J.: Lectures on Celestial Mechanics. Die Grundlehren der Mathematischen Wissenschaften in Einzeldarstellungen 187. Springer-Verlag, Berlin–Heidelberg–New York (1971), 290 pp.
47. Smale, S.: Topology and mechanics. I. *Invent. Math.* 10, 305–331 (1970); II: The planar n -body problem. *Invent. Math.* 11, 45–64 (1970)
48. Treshchev, D. V.: Introduction to Perturbation Theory of Hamiltonian Systems. FAZIS, Moscow (1998), 181 pp. (Russian)
49. Whittaker, E. T.: A Treatise on the Analytical Dynamics of Particles and Rigid Bodies with an Introduction to the Problem of Three Bodies. University Press, Cambridge (1927), 456 pp.
50. Williamson, J.: On the algebraic problem concerning the normal forms of linear dynamical systems. *Am. J. Math.* 58, 141–163 (1936)
51. Williamson, J.: The exponential representation of canonical matrices. *Am. J. Math.* 61, 897–911 (1939)
52. Wintner, A.: The Analytical Foundations of Celestial Mechanics. Univ. Press, Princeton (1941), 448 pp.

Bibliography

53. van der Aa, E., Sanders, J. A.: The 1:2:1-resonance, its periodic orbits and integrals. In: *Asymptotic Analysis, Lect. Notes Math.* 711. Springer-Verlag, Berlin (1979), 187–208
54. van der Aa, E., Verhulst, F.: Asymptotic integrability and periodic solutions of a Hamiltonian system in 1:2:2-resonance. *SIAM J. Math. Anal.* 15, 890–911 (1984)
55. Abdullah, K., Albouy, A.: On a strange resonance noticed by M. Herman. *Regul. Chaotic Dyn.* 6, No. 4, 421–432 (2001)
56. Abrarov, D. L.: Topological obstacles to the existence of conditionally linear integrals. *Vestn. Mosk. Univ., Ser. I Mat. Mekh.* 1984, No. 6, 72–75 (1984). Engl. transl.: *Mosc. Univ. Mech. Bull.* 39, No. 6, 15–19 (1984)
57. Adler, M., van Moerbeke, P.: Completely integrable systems, Euclidean Lie algebras, and curves. *Adv. Math.* 38, 267–317 (1980)
58. Adler, M., van Moerbeke, P.: The algebraic integrability of geodesic flow on $SO(4)$. *Invent. Math.* 67, 297–331 (1982)
59. Afonin, A. A., Kozlov, V. V.: Problem of falling of a disc moving on a horizontal plane. *Izv. Akad. Nauk, Mekh. Tverd. Tela* 1997, No. 1, 7–13 (1997) (Russian)
60. Aharonov, Y., Bohm, D.: Significance of electromagnetic potentials in the quantum theory. *Phys. Rev., II. Ser.* 115, 485–491 (1959)
61. Akulenko, L. D., Leshchenko, D. D., Chernous'ko, F. L.: Rapid motion around a fixed point of a heavy rigid body in resisting medium. *Izv. Akad. Nauk SSSR, Mekh. Tverd. Tela* 1982, No. 3, 5–13 (1982) (Russian)
62. Albouy, A.: Symétrie des configurations centrales de quatre corps. *C. R. Acad. Sci., Paris, Sér. I Math.* 320, No. 2, 217–220 (1995)
63. Albouy, A.: The symmetric central configurations of four equal masses. In: Saari, D. G. (ed.) et al. *Hamiltonian Dynamics and Celestial Mechanics. Jt. Summer Res. Conf.* (Seattle, WA, USA, 1995). *Contemp. Math.* 198. American Mathematical Society, Providence, R. I. (1996), 131–135
64. Allan, R. R.: Evolution of Mimas–Tethys commensurability. *Astron. J.* 74, No. 3, 497–506 (1973)
65. Andoyer, M. H.: *Cours de Mécanique Céleste. Tome I.* Gauthier-Villars, Paris (1923), 438 pp.
66. Anosov, D. V.: Averaging in systems of ordinary differential equations with rapidly oscillating solutions. *Izv. Akad. Nauk SSSR, Ser. Mat.* 24, 721–742 (1960) (Russian)

67. Anosov, D. V.: On an additive functional homology equation connected with an ergodic rotation of the circle. *Izv. Akad. Nauk SSSR, Ser. Mat.* 37, 1259–1274 (1973). Engl. transl.: *Math. USSR, Izv.* 6, 1257–1271 (1973)
68. Anosov, D. V.: On generic properties of closed geodesics. *Izv. Akad. Nauk SSSR, Ser. Mat.* 46, 675–709 (1982). Engl. transl.: *Math. USSR, Izv.* 21, 1–29 (1983)
69. Antonov, V. A.: Periodic and conditionally periodic trajectories in conservative systems under minimal smoothness conditions. I; II; III. *Trudy Astron. Observ. Leningrad Univ.* 30, 111–132 (1974); 35, 127–142 (1978); *Vestnik Leningrad Univ.* 1982, No. 13, 86–96 (1982) (Russian)
70. Aref, H., Pomphrey, N.: Integrable and chaotic motions of four vortices. I: The case of identical vortices. *Proc. R. Soc. Lond., Ser. A, Math. Phys. Eng. Sci.* 380, 359–387 (1982)
71. Arnol'd, V. I.: The stability of the equilibrium position of a Hamiltonian system of ordinary differential equations in the general elliptic case. *Dokl. Akad. Nauk SSSR* 137, 255–257 (1961). Engl. transl.: *Sov. Math., Dokl.* 2, 247–249 (1961)
72. Arnol'd, V. I. On a theorem of Liouville concerning integrable problems of dynamics. *Sib. Mat. Zh.* 4, 471–474 (1963). Engl. transl.: *Am. Math. Soc., Transl., II. Ser.* 61, 292–296 (1967)
73. Arnol'd, V. I.: Conditions for the applicability, and estimate of the error, of an averaging method for systems which pass through states of resonance in the course of their evolution. *Dokl. Akad. Nauk SSSR* 161, 9–12 (1965). Engl. transl.: *Sov. Math., Dokl.* 6, 331–334 (1965)
74. Arnol'd, V. I.: Sur une propriété topologique des applications globalement canoniques de la mécanique classique. *C. R. Acad. Sci., Paris* 261, 3719–3722 (1965)
75. Arnol'd, V. I.: The stability problem and ergodic properties for classical dynamical systems. In: *Tr. Mezhdunarod. Kongr. Mat., Moskva 1966*. Mir, Moscow (1968), 387–392. Engl. transl.: *Am. Math. Soc., Transl., II. Ser.* 70 (1968), 5–11
76. Arnol'd, V. I.: Magnetic analogues of theorems of Newton and Ivory. *Usp. Mat. Nauk* 38, No. 5, 145–146 (1983) (Russian)
77. Arnol'd, V. I.: Reversible systems. In: *Sagdeev, R. Z. (ed.) Nonlinear and Turbulent Processes in Physics. Proc. Conf. (Kiev, USSR, 1983)*. Vol. 3. Harwood Academic, Chur, NY (1984), 1161–1174
78. Arnol'd, V. I.: On some problems in symplectic topology. In: *Topology and Geometry, Rohlin Semin. 1984–1986, Lect. Notes Math.* 1346. Springer-Verlag, Berlin (1988), 1–5
79. Arnol'd, V. I.: Topological and ergodic properties of closed 1-forms with incommensurable periods. *Funkts. Anal. Prilozh.* 25, No. 2, 1–12 (1991). Engl. transl.: *Funct. Anal. Appl.* 25, No. 2, 81–90 (1991)
80. Arnol'd, V. I.: Polyintegrable flows. *Algebra Anal.* 4, No. 6, 54–62 (1992). Engl. transl.: *St. Petersburg. Math. J.* 4, No. 6, 1103–1110 (1993)
81. Arnol'd, V. I.: Remarks on eigenvalues and eigenvectors of Hermitian matrices, Berry phase, adiabatic connections and quantum Hall effect. *Sel. Math., New Ser.* 1, No. 1, 1–19 (1995)
82. Arnol'd, V. I.: Remarks concerning the Morse theory of a divergence-free vector field, the averaging method, and the motion of a charged particle in a magnetic field. *Tr. Mat. Inst. Steklova* 216, 9–19 (1997). Engl. transl.: *Proc. Steklov Inst. Math.* 216, 3–13 (1997)

83. Arnol'd, V.I.: Lectures on Partial Differential Equations. Biblioteka Studenta-Matematika 2. FAZIS, Moscow (1997), 175 pp. Engl. transl.: Universitext. Springer-Verlag, Berlin (2004), 157 pp.
84. Arnol'd, V.I.: On some problems of pseudo-periodic topology. *Mat. Prosveshcheniye*, Ser. 3, 1997, No. 1, 10–23 (1997) (Russian)
85. Arnol'd, V.I.: First steps of local symplectic algebra. In: *Differential Topology, Infinite-Dimensional Lie Algebras, and Applications*. Amer. Math. Soc. Transl. II. Ser. 194, American Mathematical Society, Providence, R. I. (1999), 1–8
86. Arnol'd, V.I.: First steps of local contact algebra. *Can. J. Math.* 51, No. 6, 1123–1134 (1999)
87. Arnol'd, V.I., Avez, A.: *Problèmes Ergodiques de la Mécanique Classique*. Monographies Internationales de Mathematiques Modernes 9. Gauthier-Villars, Paris (1967). 243 pp. Engl. transl.: *Ergodic Problems of Classical Mechanics*. The Mathematical Physics Monograph Series. W. A. Benjamin, New York–Amsterdam (1968), 286 pp.
88. Arnol'd, V.I., Gusejn-Zade, S. M., Varchenko, A. N.: *Singularities of Differentiable Maps*. Vol. I: The Classification of Critical Points, Caustics and Wave Fronts. Nauka, Moscow (1982), 304 pp. Engl. transl.: *Monographs in Mathematics* 82. Birkhäuser, Boston–Basel–Stuttgart (1985), 382 pp.
89. Arnol'd, V.I. (ed.), Kontsevich, M. (ed.), Zorich, A. (ed.): *Pseudoperiodic Topology*. Translations. Series 2. *Advances in the Mathematical Sciences*. 197(46). American Mathematical Society, Providence, R. I. (1999), 178 pp.
90. Arnol'd, V.I., Kozlov, V. V., Nejshtadt, A. I.: *Mathematical Aspects of Classical and Celestial Mechanics*. Itogi Nauki Tekh., Ser. Sovrem. Probl. Mat., Fundam. Napravleniya 3. VINITI, Moscow (1985), 304 pp. Engl. transl.: *Dynamical Systems III*, *Encycl. Math. Sci.* 3. Springer-Verlag, Berlin (1987), 291 pp.
91. Arnol'd V.I., Sevryuk M.B.: Oscillations and bifurcations in reversible systems. In: Sagdeev R.Z. (ed.) *Nonlinear Phenomena in Plasma Physics and Hydrodynamics*. Mir, Moscow (1986), 31–64
92. Aubry, S.: The twist map, the extended Frenkel–Kontorova model and the devil's staircase. In: *Order in Chaos*, Proc. Int. Conf. (Los Alamos/N. M. 1982). *Physica D* 7, 240–258 (1983)
93. Bakaj A. S.: On the coefficient of capture of a particle into accelerator. *Atom. Energiya* 21, No. 6, 503–504 (1966) (Russian)
94. Bakaj A. S.: Resonance phenomena in nonlinear systems. *Differents. Uravneniya* 2, No 4, 479–491 (1966) (Russian)
95. Bakaj A. S., Stepanovskij, Yu. P.: *Adiabatic Invariants*. Naukova Dumka, Kiev (1981), 283 pp. (Russian)
96. Bakhtin, V.I.: Averaging in multifrequency systems. *Funkts. Anal. Prilozh.* 20, No. 2, 1–7 (1986). Engl. transl.: *Funct. Anal. Appl.* 20, 83–88 (1986)
97. Bakhtin, V.I.: Averaging in a general-position single-frequency system. *Differ. Uravn.* 27, No. 9, 1493–1505 (1991). Engl. transl.: *Differ. Equations* 27, No. 9, 1051–1061 (1991)
98. Ballmann, W.: Der Satz von Lusternik und Schnirelmann. *Bonn. Math. Schr.* 102, 1–25 (1978)
99. Bangert, V.: On the existence of closed geodesics on two-spheres. *Int. J. Math.* 4, No. 1, 1–10 (1993)
100. Beaugé, C., Ferraz-Mello, S.: Capture in exterior mean motion resonances due to Poynting–Robertson drag. *Icarus* 110, No. 2, 239–260 (1994)

101. Beletskij, V. V.: *Essays on the Motion of Celestial Bodies*. Nauka, Moscow (1977), 430 pp. Engl. transl.: Birkhäuser, Basel (2001) 372 pp.
102. Benettin, G., Fassò, F.: Fast rotations of the rigid body: A study by Hamiltonian perturbation theory. I. *Nonlinearity* 9, No. 1, 137–186 (1996)
103. Benettin, G., Galgani, L., Giorgilli, A.: A proof of Nekhoroshev's theorem for the stability times in nearly integrable Hamiltonian systems. *Celestial Mech.* 37, 1–25 (1985)
104. Benettin, G., Galgani, L., Giorgilli, A.: Realization of holonomic constraints and freezing of high frequency degrees of freedom in the light of classical perturbation theory. I. *Commun. Math. Phys.* 113, 87–103 (1987)
105. Berger, M.: *Géométrie. 2: Espaces Euclidiens, Triangles, Cercles et Sphères*. Fernand Nathan, Paris (1979), 216 pp.
106. Berry, M. V.: Quantal phase factors accompanying adiabatic changes. *Proc. R. Soc. Lond., Ser. A, Math. Phys. Eng. Sci.* 392, No. 1802, 45–57 (1984)
107. Berry, M. V.: Classical adiabatic angles and quantal adiabatic phase. *J. Phys. A* 18, 15–27 (1985)
108. Berti, M., Bolle, P.: Diffusion time and splitting of separatrices for nearly integrable isochronous Hamiltonian systems. *Atti Accad. Naz. Lincei, Cl. Sci. Fis. Mat. Nat., IX. Ser., Rend. Lincei, Mat. Appl.* 11, No. 4, 235–243 (2000)
109. Bessi, U.: An approach to Arnold's diffusion through the calculus of variations. *Nonlinear Anal., Theory Methods Appl.* 26, No. 6, 1115–1135 (1996)
110. Bibikov, Yu. N.: A sharpening of a theorem of Moser. *Dokl. Akad. Nauk SSSR* 213, 766–769 (1973). Engl. transl.: *Sov. Math., Dokl.* 14, 1769–1773 (1973)
111. Bibikov, Yu. N.: *Multifrequency Nonlinear Oscillations and their Bifurcations*. Leningrad Univ., Leningrad (1991), 144 pp. (Russian)
112. Birkhoff, G.: *Hydrodynamics. A Study in Logic, Fact and Similitude*. Princeton Univ. Press, Princeton, New Jersey (1960), 184 pp.
113. Blekhman, I. I.: *Vibration Mechanics*. Nauka, Moscow (1994), 398 pp. Engl. transl.: *Vibrational Mechanics. Nonlinear Dynamic Effects, General Approach, Applications*. World Scientific, Singapore (2000), 536 pp.
114. Bliss, G. A.: *Lectures on the Calculus of Variations*. Univ. of Chicago Press, Chicago (1946), 296 pp.
115. Bogolyubov, N. N.: Perturbation theory in nonlinear mechanics. In: *Collection of Papers of Inst. Construction Mekhaniki Akad. Nauk UkrSSR* 14 (1950), 9–34 (Russian)
116. Bogolyubov, N. N., Mitropol'skij, Yu. A., Samoilenko, A. M.: *Methods of Accelerated Convergence in Nonlinear Mechanics*. Naukova Dumka, Kiev (1969), 248 pp. Engl. transl.: Hindustan Publishing Corporation, Delhi, India; Springer-Verlag, Berlin–Heidelberg–New York (1976), 291 pp.
117. Bogolyubov, N. N., Zubarev, D. N.: Method of asymptotic approximation for systems with rotating phase and its application to motion of charged particles in a magnetic field. *Ukr. Mat. Zh.* 7, 5–17 (1955) (Russian)
118. Bogoyavlenskij, O. I.: Conformal symmetries of dynamical systems and Poincaré 1892 concept of iso-energetic non-degeneracy. *C. R. Acad. Sci., Paris, Sér. I, Math.* 326, No. 2, 213–218 (1998)
119. Bogoyavlenskij, O. I.: Necessary and sufficient conditions for two Poincaré concepts of nondegeneracy of integrable Hamiltonian systems. *Dokl. Akad. Nauk* 360, No. 3, 295–298 (1998). Engl. transl.: *Dokl. Math.* 57, No. 3, 377–379 (1998)
120. Bohm, D.: *Quantum Theory*. Constable, London (1952), 646 pp.

121. Bolotin, S. V.: Libration motions of natural dynamical systems. Vestn. Mosk. Univ., Ser. I Mat. Mekh. 1978, No. 6, 72–77 (1978). Engl. transl.: Mosc. Univ. Mech. Bull. 33, No. 5–6, 49–53 (1978).
122. Bolotin, S. V.: The existence of homoclinic motions. Vestn. Mosk. Univ., Ser. I Mat. Mekh. 1983, No. 6, 98–103 (1983). Engl. transl.: Mosc. Univ. Math. Bull. 38, No. 6, 117–123 (1983)
123. Bolotin, S. V.: Nonintegrability of the n -center problem for $n > 2$. Vestn. Mosk. Univ., Ser. I Mat. Mekh. 1984, No. 3, 65–68 (1984). Engl. transl.: Mosc. Univ. Mech. Bull. 39, No. 3, 24–28 (1984)
124. Bolotin, S. V.: A comment on the Routh method and the Hertz hypothesis. Vestn. Mosk. Univ., Ser. I Mat. Mekh. 1986, No. 5, 51–53 (1986). Engl. transl.: Mosc. Univ. Mech. Bull. 41, No. 5, 21–25 (1986)
125. Bolotin, S. V.: Condition for nonintegrability in the sense of Liouville of Hamiltonian systems. Vestn. Mosk. Univ. Ser. I Mat. Mekh. 1986, No. 3, 58–64 (1986) (Russian)
126. Bolotin, S. V.: Homoclinic orbits of geodesic flows on surfaces. Russ. J. Math. Phys. 1, No. 3, 275–288 (1993)
127. Bolotin, S. V.: Homoclinic orbits to invariant tori of Hamiltonian systems. In: Kozlov, V. V. (ed.) Dynamical Systems in Classical Mechanics. Transl., Ser. 2, Am. Math. Soc. 168(25) (1995), 21–90
128. Bolotin, S. V.: Invariant sets of Hamiltonian systems and variational methods. In: Chatterji, S. D. (ed.) Proceedings of the International Congress of Mathematicians, ICM'94, August 3–11, 1994, Zürich, Switzerland. Vol. II. Birkhäuser, Basel (1995), 1169–1178
129. Bolotin, S. V., Kozlov, V. V.: Libration in systems with many degrees of freedom. Prikl. Mat. Mekh. 42, No. 2, 245–250 (1978). Engl. transl.: J. Appl. Math. Mech. 42, No. 2, 256–261 (1980)
130. Bolotin, S. V., Kozlov, V. V.: On asymptotic solutions of dynamical equations. Vestn. Mosk. Univ., Ser. I Mat. Mekh. 1980, No. 4, 84–89 (1980). Engl. transl.: Mosc. Univ. Mech. Bull. 35, No. 3–4, 82–88 (1980).
131. Bolotin, S. V., Kozlov, V. V.: Symmetry fields of geodesic flows. Russ. J. Math. Phys. 3, No. 3, 279–295 (1995)
132. Bolotin, S. V., Negrini, P.: Asymptotic solutions of Lagrangian systems with gyroscopic forces. Nonlinear Differ. Equ. Appl. 2, No. 4, 417–444 (1995)
133. Bolotin, S. V., Negrini, P.: A variational criterion for nonintegrability. Rus. J. Math. Phys. 5, No. 4, 415–436 (1998)
134. Bolotin, S. V., Rabinowitz, P. H.: A variational construction of chaotic trajectories for a reversible Hamiltonian system. J. Differ. Equations 148, No. 2, 364–387 (1998)
135. Bolotin, S. V., Treshchev, D.: Unbounded growth of energy in nonautonomous Hamiltonian systems. Nonlinearity 12, No. 2, 365–388 (1999)
136. Bolsinov, A. V., Fomenko, A. T.: Introduction to the Topology of Integrable Hamiltonian Systems. Nauka, Moscow (1997), 352 pp. (Russian)
137. Borisov, A. V., Mamaev, I. S.: Poisson structures and Lie algebras in Hamiltonian mechanics. Research Centre “Regular and chaotic dynamics”, Izhevsk (1999), 464 pp. (Russian)
138. Borisov, A. V., Mamaev, I. S.: Dynamics of Rigid Body. Research Centre “Regular and chaotic dynamics”, Moscow–Izhevsk (2001), 384 pp. (Russian)
139. Born, M., Fok, V.: Beweis des Adiabatenatzes. Z. Phys. 51, 165–169 (1928)

140. Boshernitzan, M. D.: Quantitative recurrence results. *Invent. Math.* 113, No. 3, 617–631 (1993)
141. Bourgain, J.: On Melnikov's persistency problem, *Math. Res. Lett.* 4, No. 4, 445–458 (1997)
142. Brajlov, A. V.: Some cases of complete integrability of the Euler equations, and applications. *Dokl. Akad. Nauk SSSR* 268, 1043–1046 (1983). Engl. transl.: *Sov. Math., Dokl.* 27, 209–212 (1983)
143. Breakwell, J. V., Kamel, A. A., Ratner, M. J.: Station-keeping for a translunar communication station. *Celestial Mech.* 10, 357–373 (1974)
144. Brendelev, V. N.: On the realization of constraints in nonholonomic mechanics. *Prikl. Mat. Mekh.* 45, No. 3, 481–487 (1981). Engl. transl.: *J. Appl. Math. Mech.* 45, No. 3, 351–355 (1982)
145. Broer, H. W., Huitema, G. B.: Unfoldings of quasi-periodic tori in reversible systems. *J. Dyn. Differ. Equations* 7, No. 1, 191–212 (1995)
146. Broer, H. W., Huitema, G. B., Sevryuk, M. B.: Families of quasi-periodic motions in dynamical systems depending on parameters. In: Broer, H. W. (ed.) et al. *Nonlinear Dynamical Systems and Chaos. Proc. Dynamical Systems Conf. (Groningen, Netherlands, 1995)*. *Prog. Nonlinear Differ. Equ. Appl.* 19. Birkhäuser, Boston, MA (1996), 171–211
147. Broer, H. W., Huitema, G. B., Takens, F., Braaksma, B. L. J.: Unfoldings and Bifurcations of Quasi-Periodic Tori. *Mem. Am. Math. Soc.* 83, No. 421. American Mathematical Society, Providence, R. I. (1990), 175 pp.
148. Brothers, J. D., Haberman, R.: Slow passage through a homoclinic orbit with subharmonic resonances. *Stud. Appl. Math.* 101, No. 2, 211–232 (1998)
149. Bruhwiler, D. L., Cary, J. R.: Diffusion of particles in a slowly modulated wave. *Physica D* 40, No. 2, 265–282 (1989)
150. Bryuno, A. D.: Instability in a Hamiltonian system and distribution of asteroids. *Mat. Sb., N. Ser.* 83, No. 2, 273–312 (1970). Engl. transl.: *Math. USSR, Sb.* 12, No. 2, 271–312 (1970)
151. Bryuno, A. D.: Analytical form of differential equations. *Tr. Mosk. Mat. O-va* 25, 119–262 (1971). Engl. transl.: *Trans. Mosc. Math. Soc.* 25, 131–288 (1973)
152. Bryuno, A. D.: Study on the Restricted Three-Body Problem. 1. Periodic Solutions of Hamiltonian System. *Inst. Prikl. Mat. Akad. Nauk SSSR, Moscow* (1978), 44 pp. (Russian)
153. Bryuno, A. D.: *The Local Method of Nonlinear Analysis of Differential Equations*. Nauka, Moscow (1979), 253 pp. Engl. transl. as Part I of: Bryuno, A. D.: *Local Methods in Nonlinear Differential Equations*. Springer-Verlag, Berlin (1989), 1–272
154. Bryuno, A. D.: Normalization of a Hamiltonian system near an invariant cycle or torus. *Usp. Mat. Nauk* 44, No. 2(266), 49–78 (1989). Engl. transl.: *Russ. Math. Surv.* 44, No. 2, 53–89 (1989)
155. Bryuno, A. D.: *The Restricted Three-Body Problem: Plane Periodic Orbits*. Nauka, Moscow (1990), 296 pp. Engl. transl.: *De Gruyter Expositions in Mathematics* 17. Walter de Gruyter, Berlin (1994), 362 pp.
156. Büchner, J., Zelenyj, L. M.: Regular and chaotic charged particle motion in magnetotaillike field reversals. 1: Basic theory of trapped motion. *J. Geophys. Res.* 94, No. A9, 11821–11842 (1989)
157. Bulatovich, R. M.: Existence of solutions of the Hamilton–Jacobi equation in the neighborhood of nondegenerate equilibrium position. *Prikl. Mat. Mekh.* 47,

- No. 2, 330–333 (1983). Engl. transl.: *J. Appl. Math. Mech.* 47, No. 2, 277–280 (1984)
158. Burd, V. Sh., Matveev, V. N.: *Asymptotic Methods on an Infinite Interval in Problems of Nonlinear Mechanics*. Yaroslavl' Univ., Yaroslavl' (1985), 70 pp. (Russian)
 159. Burgers, J. M.: *Adiabatic invariants of mechanical systems, I, II, III*. *Proc. Roy. Acad. Amsterdam* 20, 149–169 (1917/18)
 160. van der Burgh, A. H. P.: *Studies in the Asymptotic Theory of Nonlinear Resonance*. Doctoral dissertation. Technische Hogeschool, Delft (1974), 85 pp.
 161. Carathéodory, C.: *Der Schlitten*. *Z. Angew. Math. Mech.* 13, 71–76 (1933)
 162. Cary, J. R., Escande, D. F., Tennyson, J. L.: *Adiabatic invariant change due to separatrix crossing*. *Phys. Rev. A* 34, No. 5, 4256–4275 (1986)
 163. Cary, J. R., Skodje, R. T.: *Phase change between separatrix crossings*. *Physica D* 36, No. 3, 287–316 (1989)
 164. Cassels, J. W. S.: *An Introduction to Diophantine Approximation*. *Cambridge Tracts in Mathematics and Mathematical Physics* 45. At the University Press, Cambridge (1957), 166 pp.
 165. Chaplygin, S. A.: *To the theory of motion of non-holonomic systems. Theorem on reducing factor*. In: *Chaplygin, S. A. Collection of Works. Vol. 1*. Akad. Nauk SSSR, Leningrad (1933), 207–215 (Russian)
 166. Chazy, J.: *Sur certaines trajectoires du problème des n corps*. *Bulletin astronomique* 35, 321–389 (1918)
 167. Chebotarev, N. G.: *Theory of Lie Groups*. Gostekhizdat, Moscow–Leningrad (1940), 396 pp. (Russian)
 168. Chelomej, V. N.: *On the possibility of raising the stability of elastic systems by means of vibrations*. *Dokl. Akad. Nauk SSSR* 110, 345–347 (1956) (Russian)
 169. Chelomej, V. N.: *Mechanical paradoxes caused by vibrations*. *Dokl. Akad. Nauk SSSR* 270, No. 1, 62–67 (1983). Engl. transl.: *Sov. Phys., Dokl.* 28, 387–390 (1983)
 170. Chenciner, A., Montgomery, R.: *A remarkable periodic solution of the three-body problem in the case of equal masses*. *Ann. Math. (2)* 152, No. 3, 881–901 (2000)
 171. Chenciner, A., Venturelli, A.: *Minima de l'intégrale d'action du problème newtonien de 4 corps de masses égales dans \mathbb{R}^3 : Orbites "hip-hop"*. *Celest. Mech. Dyn. Astron.* 77, No. 2, 139–152 (2000)
 172. Cheng, Ch.-Q.: *Birkhoff–Kolmogorov–Arnold–Moser tori in convex Hamiltonian systems*. *Commun. Math. Phys.* 177, No. 3, 529–559 (1996)
 173. Cheng, Ch.-Q.: *Lower dimensional invariant tori in the regions of instability for nearly integrable Hamiltonian systems*. *Commun. Math. Phys.* 203, No. 2, 385–419 (1999)
 174. Cheng, Ch.-Q., Sun, Yi-S.: *Existence of KAM tori in degenerate Hamiltonian systems*. *J. Differ. Equations* 114, No. 1, 288–335 (1994)
 175. Cheng, Ch.-Q., Wang, Sh.: *The surviving of lower dimensional tori from a resonant torus of Hamiltonian systems*. *J. Differ. Equations* 155, No. 2, 311–326 (1999)
 176. Cheng, Ch.-Q., Yan, J.: *Existence of diffusion orbits in a priori unstable Hamiltonian systems*. *J. Differ. Geom.* 67, No. 3, 457–517 (2004)
 177. Chernikov, N. A.: *The Kepler problem in the Lobachevsky space and its solution*. *Acta Phys. Polon. B* 23, No. 2, 115–122 (1992)

178. Chernous'ko, F. L.: On resonance in an essentially non-linear system. *Zh. Vychislit. Mat. Mat. Fiz.* 3, 131–144 (1963). Engl. transl.: U.S.S.R. Comput. Math. Math. Phys. 3, 168–185 (1965)
179. Cherry, T. M.: On the solution of Hamiltonian systems of differential equations in the neighborhood of a singular point. *Proc. London Math. Soc.* (2) 27, 151–170 (1927)
180. Chetaev, N. G.: On instability of an equilibrium position in some cases where the function of forces is not maximum. *Prikl. Mat. Mekh.* 16, No. 1, 89–93 (1952) (Russian)
181. Chetaev, N. G.: *The Stability of Motion*. Nauka, Moscow (1990), 175 pp.. Engl. transl. of 1st ed.: Pergamon Press, London (1961), 200 pp.
182. Chierchia, L.: Arnold instability for nearly-integrable analytic Hamiltonian systems. In: Ambrosetti, A. (ed.) et al. *Variational and Local Methods in the Study of Hamiltonian Systems*. Proceedings of the Workshop, Trieste, Italy, October 24–28, 1994 and the School, Trieste, Italy, 1994. World Scientific, Singapore (1995), 17–33
183. Chierchia, L.: KAM lectures. In: *Dynamical Systems. Part I. Hamiltonian Systems and Celestial Mechanics*. Selected papers from the Research Trimester held in Pisa, Italy, February 4 – April 26, 2002. Pubblicazioni del Centro di Ricerca Matematica Ennio de Giorgi, Proceedings. Scuola Normale Superiore, Pisa (2003), 1–55
184. Chierchia, L., Falcolini, C.: A direct proof of a theorem by Kolmogorov in Hamiltonian systems. *Ann. Sc. Norm. Super. Pisa, Cl. Sci., IV. Ser.* 21, No. 4, 541–593 (1994)
185. Chierchia, L., Falcolini, C.: Compensations in small divisor problems. *Commun. Math. Phys.* 175, No. 1, 135–160 (1996)
186. Chierchia, L., Gallavotti, G.: Drift and diffusion in phase space. *Ann. Inst. Henri Poincaré, Phys. Théor.* 60, No. 1, 1–144 (1994); Erratum: 68, No. 1, 135 (1998)
187. Chierchia, L., Qian, D.: Moser's theorem for lower dimensional tori. *J. Differ. Equations* 206, No. 1, 55–93 (2004)
188. Chirikov, B. V.: The passage of a nonlinear oscillatory system through resonance. *Dokl. Akad. Nauk SSSR* 125, 1015–1018 (1959). Engl. transl.: *Sov. Phys., Dokl.* 4, 390–394 (1959)
189. Chirikov, B. V.: A universal instability of many-dimensional oscillator systems. *Phys. Rep.* 52, No. 5, 264–379 (1979)
190. Chow, S.-N., Li, Y., Yi, Y.: Persistence of invariant tori on submanifolds in Hamiltonian systems. *J. Nonlinear Sci.* 12, No. 6, 585–617 (2002)
191. Chudnenko, A. N.: To stability of equilibrium states of Hamiltonian systems with two degrees of freedom in the case of double zero root. *Mekh. Tverd. Tela* 10, 54–60 (1978) (Russian)
192. Cicogna, G., Gaeta, G.: *Symmetry and Perturbation Theory in Nonlinear Dynamics*. Lecture Notes in Physics. New Series m: Monographs m57. Springer-Verlag, Berlin (1999), 208 pp.
193. Cong, F., Küpper, T., Li, Y., You, J.: KAM-type theorem on resonant surfaces for nearly integrable Hamiltonian systems. *J. Nonlinear Sci.* 10, No. 1, 49–68 (2000)
194. Cong, F., Li, Y.: Invariant hyperbolic tori for Hamiltonian systems with degeneracy. *Discrete Contin. Dyn. Syst.* 3, No. 3, 371–382 (1997)

195. Cong, F., Li, Y., Jin, D.: Invariant hyperbolic tori for Hamiltonian systems with Rüssmann nondegeneracy conditions. *Rocky Mt. J. Math.* 29, No. 3, 831–851 (1999)
196. Conley, C. C., Zehnder, E.: The Birkhoff–Lewis fixed point theorem and a conjecture of V. I. Arnold. *Invent. Math.* 73, 33–49 (1983)
197. Coti Zelati V., Rabinowitz, P. H.: Heteroclinic solutions between stationary points at different energy levels. *Topol. Methods Nonlinear Anal.* 17, No. 1, 1–21 (2001)
198. Cresson, J.: Conjecture de Chirikov et optimalité des exposants de stabilité du théorème de Nekhoroshev. Preprint 98/40, Université de Besançon (2000)
199. Cresson, J.: The transfer lemma for Graff tori and Arnold diffusion time. *Discrete Contin. Dyn. Syst.* 7, No. 4, 787–800 (2001)
200. Cresson, J., Guillet, C.: Periodic orbits and Arnold diffusion. *Discrete Contin. Dyn. Syst.* 9, No. 2, 451–470 (2003)
201. Cushman, R.: Examples of nonintegrable analytic Hamiltonian vector fields with no small divisors. *Trans. Am. Math. Soc.* 238, 45–55 (1978)
202. Delshams, A., Gutiérrez, P.: Estimates on invariant tori near an elliptic equilibrium point of a Hamiltonian system. *J. Differ. Equations* 131, No. 2, 277–303 (1996)
203. Delshams, A., de la Llave, R., Seara, T. M.: A geometric approach to the existence of orbits with unbounded energy in generic periodic perturbations by a potential of generic geodesic flows of \mathbb{T}^2 . *Commun. Math. Phys.* 209, No. 2, 353–392 (2000)
204. Delshams A., de la Llave, R., Seara, T. M.: A geometric mechanism for diffusion in Hamiltonian systems overcoming the large gap problem: heuristics and rigorous verification on a model. *Mem. Am. Math. Soc.* 179, No. 844. American Mathematical Society, Providence, R. I. (2006), 141 pp.
205. Delshams, A., Seara, T. M.: An asymptotic expression for the splitting of separatrices of the rapidly forced pendulum. *Commun. Math. Phys.* 150, No. 3, 433–463 (1992)
206. Deprit, A., Deprit-Bartholomé, A.: Stability of the triangular Lagrangian points. *Astron. J.* 72, No. 2, 173–179 (1967)
207. Deprit, A., Henrard, J., Rom, A.: Analytical Lunar ephemeris: Brouwer’s suggestion. *Astron. J.* 75, No. 6, 747–750 (1970)
208. Deryabin, M. V.: The Dirac–Hamiltonian formalism and the realization of constraints by small masses. *Prikl. Mat. Mech.* 64, No. 1, 41–45 (2000). Engl. transl.: *J. Appl. Math. Mech.* 64, No. 1, 35–39 (2000)
209. Diminnie, D. C., Haberman, R.: Slow passage through a saddle–center bifurcation. *J. Nonlinear Sci.* 10, No. 2, 197–221 (2000)
210. Diminnie, D. C., Haberman, R.: Slow passage through homoclinic orbits for the unfolding of a saddle–center bifurcation and the change in the adiabatic invariant. *Physica D* 162, No. 1–2, 34–52 (2002)
211. Dirac, P. A. M.: The adiabatic invariance of the quantum integrals. *Proc. R. Soc. Lond., Ser. A, Math. Phys. Eng. Sci.* 107, 725–734 (1925)
212. Dodson, M. M., Rynne, B. P., Vickers, J. A. G.: Averaging in multifrequency systems. *Nonlinearity* 2, No. 1, 137–148 (1989)
213. Dolgopyat D.: Repulsion from Resonances. Preprint Univ. of Maryland (2004), 66 pp.

214. Douady, R.: Une démonstration directe de l'équivalence des théorèmes de tores invariants pour difféomorphismes et champs de vecteurs. *C. R. Acad. Sci., Paris, Sér. I Math.* 295, 201–204 (1982)
215. Douady, R., Le Calvez, P.: Exemple de point fixe elliptique non topologiquement stable en dimension 4. *C. R. Acad. Sci., Paris, Sér. I Math.* 296, 895–898 (1983)
216. Dubrovin, B. A., Matveev, V. B., Novikov, S. P.: Non-linear equations of Korteweg–de Vries type, finite-zone linear operators, and Abelian varieties. *Usp. Mat. Nauk* 31, No. 1(187), 55–136 (1976). Engl. transl.: *Russ. Math. Surv.* 31, No. 1, 59–146 (1976)
217. Duistermaat, J. J.: Bifurcations of periodic solutions near equilibrium points of Hamiltonian systems. In: *Bifurcation Theory and Applications, Lect. 2nd Sess. CIME, Montecatini/Italy 1983, Lect. Notes Math.* 1057. Springer-Verlag, Berlin (1984), 57–105
218. Duistermaat, J. J.: Non-integrability of the 1:1:2-resonance. *Ergodic Theory Dyn. Syst.* 4, 553–568 (1984)
219. Dykhne, A. M.: Quantum transitions in the adiabatic approximation. *Zh. Eksper. Teor. Fiz.* 38, 570–578 (1960). Engl. transl.: *Sov. Phys., JETP* 11, 411–415 (1960)
220. Dynnikov, I. A.: Intersections of level surfaces of pseudoperiodic functions. *Usp. Mat. Nauk* 49, No. 1(295), 213–214 (1994). Engl. transl.: *Russ. Math. Surv.* 49, No. 1, 229–230 (1994)
221. Ehl'yasberg, P. E., Timokhova, T. A.: Control of motion of a space apparatus in a neighbourhood of a collinear libration centre in the restricted elliptic three-body problem. *Kosmich. Issled.* 24, No. 4, 497–512 (1986) (Russian)
222. Ehl'yasberg, P. E.; Timokhova, T. A.: A condition for the boundedness of a spacecraft's orbit in the vicinity of a collinear libration center of the restricted elliptical three-body problem. *Dokl. Akad. Nauk SSSR* 293, 55–58 (1987). Engl. transl.: *Sov. Phys., Dokl.* 32, 171–172 (1987)
223. Ekeland, I., Lasry, J.-M.: On the number of periodic trajectories for a Hamiltonian flow on a convex energy surface. *Ann. Math. (2)* 112, 283–319 (1980)
224. Eliasson, L. H.: Compensations of signs in a small divisor problem. In: *Dazord, P. (ed.) et al. Aspects Dynamiques et Topologiques des Groupes Infinités de Transformation de la Mécanique, Sémin. Sud-Rhodanien Géom. VI, Lyon/France 1986, Trav. Cours* 25, Hermann, Paris (1987), 37–48
225. Eliasson, L. H.: Perturbations of stable invariant tori for Hamiltonian systems. *Ann. Sc. Norm. Super. Pisa, Cl. Sci., IV. Ser.* 15, No. 1, 115–147 (1988)
226. Eliasson, L. H.: Biasymptotic solutions of perturbed integrable Hamiltonian systems. *Bol. Soc. Bras. Mat., Nova Sér.* 25, No. 1, 57–76 (1994)
227. Eliasson, L. H.: Absolutely Convergent Series Expansions for Quasi Periodic Motions. University of Stockholm (1988) (Report 2–88), 31 pp.; *Math. Phys. Electron. J.* 2, No. 4, Paper 4 (1996), 33 pp.
228. Ellison, J. A., Kummer, M., Sáenz, A. W.: Transcendentally small transversality in the rapidly forced pendulum. *J. Dyn. Differ. Equations* 5, No. 2, 241–277 (1993)
229. Elskens, Y., Escande, D.F.: Slowly pulsating separatrices sweep homoclinic tangles where islands must be small: An extension of classical adiabatic theory. *Nonlinearity* 4, No. 3, 615–667 (1991)

230. Evtushenko, J. G.: Influence of tangential acceleration on the motion of a satellite. *Prikl. Mat. Mekh.* 30, No. 3, 594–598 (1966). Engl. transl.: *J. Appl. Math. Mech.* 30, No. 3, 710–716 (1967)
231. Farquhar, R. W., Kamel, A. A.: Quasi-periodic orbits about the translunar libration point. *Celest. Mech.* 7, 458–473 (1973)
232. Farquhar, R. W., Muhonen, D. P., Richardson, D. L.: Mission design for a halo orbiter of the Earth. *J. of Spacecraft and Rockets* 14, No. 3, 170–177 (1977)
233. Fathi, A.: Orbites hétéroclines et ensemble de Peierls. *C. R. Acad. Sci., Paris, Sér. I, Math.* 326, No. 10, 1213–1216 (1998)
234. Fedoryuk, M. V. An adiabatic invariant of a system of linear oscillators and scattering theory. *Differ. Uravn.* 12, No. 6, 1012–1018 (1976). Engl. transl.: *Differ. Equations* 12, 713–718 (1977)
235. Féjóz, J.: Démonstration du ‘théorème d’Arnold’ sur la stabilité du système planétaire (d’après Herman). *Ergodic Theory Dyn. Syst.* 24, No. 5, 1521–1582 (2004).
236. Fomenko, A. T.: *Symplectic Geometry. Methods and Applications.* Moscow Univ., Moscow (1988), 414 pp. Engl. transl.: *Symplectic Geometry. Advanced Studies in Contemporary Mathematics* 5. Gordon and Breach Science Publishers, New York etc. (1988), 387 pp.
237. Freidlin, M. I.: Random and deterministic perturbations of nonlinear oscillators. *Doc. Math., J. DMV, Extra Vol. ICM Berlin 1998, vol. III*, 223–235 (1998)
238. Gajdukov, E. V.: Asymptotic geodesics on a Riemannian manifold non-homeomorphic to the sphere. *Dokl. Akad. Nauk SSSR* 169, 999–1001 (1966). Engl. transl.: *Sov. Math., Dokl.* 7, 1033–1035 (1966)
239. Galgani, L., Giorgilli, A., Strelcyn, J.-M.: Chaotic motions and transition to stochasticity in the classical problem of the heavy rigid body with a fixed point. *Nuovo Cimento B* (11) 61, no. 1, 1–20 (1981)
240. Galin, D. M.: Versal deformations of linear Hamiltonian systems. *Tr. Semin. Im. I. G. Petrovskogo* 1, 63–74 (1975). Engl. transl.: *Transl., Ser. 2, Am. Math. Soc.* 118, 1–12 (1982).
241. Gallavotti, G.: Twistless KAM tori, quasi flat homoclinic intersections, and other cancellations in the perturbation series of certain completely integrable Hamiltonian systems. A review. *Rev. Math. Phys.* 6, No. 3, 343–411 (1994)
242. Gallavotti, G., Gentile, G.: Hyperbolic low-dimensional invariant tori and summations of divergent series. *Commun. Math. Phys.* 227, No. 3, 421–460 (2002)
243. Gallavotti, G., Gentile, G., Giuliani, A.: Fractional Lindstedt series. *J. Math. Phys.* 47, No. 1, 012702-1–012702-33 (2006)
244. Gardner, C. S.: Adiabatic invariants of periodic classical systems. *Phys. Rev.* (2) 115, 791–794 (1959)
245. Gel’freich, V. G.: Conjugation to a shift and the splitting of invariant manifolds. *Appl. Math.* 24, No. 2, 127–140 (1996)
246. Gel’freich, V. G.: Separatrix Splitting for a High-Frequency Perturbation of the Pendulum. *Universitat de Barcelona, Math. Preprint Series, No. 195* (1996), 29 pp.
247. Gel’freich, V. G.: Reference systems for splitting of separatrices. *Nonlinearity* 10, No. 1, 175–193 (1997)
248. Gel’freich, V. G.: A proof of the exponentially small transversality of the separatrices for the standard map. *Commun. Math. Phys.* 201, No. 1, 155–216 (1999)

249. Gel'freich, V. G.: Separatrix splitting for a high-frequency perturbation of the pendulum. *Russ. J. Math. Phys.* 7, No. 1, 48–71 (2000)
250. Gel'freich, V. G., Lazutkin, V. F.: Splitting of separatrices: Perturbation theory and exponential smallness. *Usp. Mat. Nauk* 56, No. 3, 79–142 (2001). Engl. transl.: *Russ. Math. Surv.* 56, No. 3, 499–558 (2001)
251. Gel'freich, V. G., Lazutkin, V. F., Svanidze, N. V.: A refined formula for the separatrix splitting for the standard map. *Physica D* 71, No. 1–2, 82–101 (1994)
252. Gel'freich, V. G., Lazutkin, V. F., Tabanov, M. B.: Exponentially small splittings in Hamiltonian systems. *Chaos* 1, No. 2, 137–142 (1991)
253. Gentile, G., Gallavotti, G.: Degenerate elliptic resonances. *Commun. Math. Phys.* 257, No. 2, 319–362 (2005)
254. Gentile, G., Mastropietro, V.: Methods for the analysis of the Lindstedt series for KAM tori and renormalizability in classical mechanics. A review with some applications. *Rev. Math. Phys.* 8, No. 3, 393–444 (1996)
255. Gerver, J. L.: The existence of pseudocollisions in the plane. *J. Differ. Equations* 89, No. 1, 1–68 (1991)
256. Giacaglia, G. E. O.: *Perturbation Methods in Non-Linear Systems*. Applied Mathematical Science 8. Springer-Verlag, New York–Heidelberg–Berlin (1972), 369 pp.
257. Gidea, M., de la Llave, R.: Topological methods in the instability problem of Hamiltonian systems. *Discrete Contin. Dyn. Syst., Ser. A* 14, No. 2, 295–328 (2006)
258. Ginzburg, V. L.: New generalizations of Poincaré's geometric theorem. *Funkts. Anal. Prilozh.* 21, No. 2, 16–22 (1987). Engl. transl.: *Funct. Anal. Appl.* 21, 100–106 (1987)
259. Giorgilli, A.: Exponential stability of Hamiltonian systems. In: *Dynamical Systems. Part I. Hamiltonian Systems and Celestial Mechanics*. Selected papers from the Research Trimester held in Pisa, Italy, February 4 – April 26, 2002. Pubblicazioni del Centro di Ricerca Matematica Ennio de Giorgi, Proceedings. Scuola Normale Superiore, Pisa (2003), 87–198
260. Goldreich, P., Peale, S.: Spin-orbit coupling in the Solar System. *Astron. J.* 71, No. 6, 425–438 (1966)
261. Golin, S., Knauf, A., Marmi, S.: The Hannay angles: Geometry, adiabaticity, and an example. *Commun. Math. Phys.* 123, No. 1, 95–122 (1989)
262. Gómez, G., Simó, C., Llibre, J., Martínez, R.: *Dynamics and Mission Design near Libration Points. Vol. 1: Fundamentals: The Case of Collinear Libration Points*. World Scientific Monograph Series in Mathematics 2. World Scientific, Singapore (2000), 500 pp.
263. Gordon, W. B.: On the relation between period and energy in periodic dynamical systems. *J. Math. Mech.* 19, 111–114 (1969)
264. Gorelyshev, I. V., Nejshtadt, A. I.: On adiabatic perturbation theory for systems with elastic collisions. *Prikl. Mat. Mekh.* 70, No. 1, 6–19 (2006). Engl. transl.: *J. Appl. Math. Mech.* 70, No. 1 (2006)
265. Graff, S. M.: On the conservation of hyperbolic invariant tori for Hamiltonian systems. *J. Differ. Equations* 15, 1–69 (1974)
266. Grayson, M. A.: Shortening embedded curves. *Ann. Math. (2)* 129, No. 1, 71–111 (1989)
267. Greenberg, R. J.: Evolution of satellite resonances by tidal dissipation. *Astron. J.* 78, No. 4, 338–346 (1973)

268. Gurevich, A. V., Tsedilina, E. E.: Superlong Propagation of Short Radiowaves. Nauka, Moscow (1979), 268 pp. Engl. transl.: Long Distance Propagation of Hf Radio Waves (Physics and Chemistry in Space). Springer-Verlag, Berlin (1985), 344 pp.
269. Gurtovnik, A. A., Kogan, V. P., Nejmark, Yu. I.: Invariant toroidal manifolds and resonances in discrete dynamical systems. Ukr. Mat. Zh. 27, 167–182 (1975). Engl. transl.: Ukr. Math. J. 27, 132–143 (1975)
270. Gurtovnik, A. A., Nejmark, Yu. I.: Integral manifolds of differential equations with rapidly rotating phase. Izv. VUZ., Radiofizika 12, No. 11, 1597–1608 (1969) (Russian)
271. Gustavson, F.: On constructing formal integrals of a Hamiltonian system near an equilibrium position point. Astron. J. 71, No. 8, 670–686 (1966)
272. Hagedorn, P.: Über die Instabilität konservativer Systeme mit gyroskopischen Kräften. Arch. Ration. Mech. Anal. 58, 1–9 (1975)
273. Hamilton, R. S.: The inverse function theorem of Nash and Moser. Bull. Am. Math. Soc., New Ser. 7, 65–222 (1982)
274. Hampton, M., Moeckel, R.: Finiteness of relative equilibria of the four-body problem. Preprint (2004)
275. Hannay, J. H.: Angle variable holonomy in adiabatic excursion of an integrable Hamiltonian. J. Phys. A 18, No. 2, 221–230 (1985)
276. Henrard, J.: Capture into resonance: An extension of the use of adiabatic invariants. Celestial Mech. 27, 3–22 (1982)
277. Henrard, J.: The adiabatic invariant in classical mechanics. In: Jones, C. K. R. T. (ed.) et al. Dynamics Reported. Expositions in Dynamical Systems. New series. Volume 2. Springer-Verlag, Berlin (1993), 117–235
278. Herman, M. R.: Sur les Courbes Invariantes par les Difféomorphismes de l'Anneau. Vol. 1. Complété par un Appendice au Chapitre 1 de Albert Fathi. Astérisque 103–104. Société Mathématique de France, Paris (1983), 221 pp.
279. Herman, M. R.: Sur les Courbes Invariantes par les Difféomorphismes de l'Anneau. Volume 2. Astérisque 144. Société Mathématique de France, Paris (1986), 248 pp.
280. Herman, M. R.: Inégalités “a priori” pour des tores lagrangiens invariants par des difféomorphismes symplectiques. Publ. Math., Inst. Hautes Étud. Sci. 70, 47–101 (1989)
281. Higgs, P. W.: Dynamical symmetries in a spherical geometry. I. J. Phys. A 12, 309–323 (1979)
282. Hingston, N.: On the growth of the number of closed geodesics on the two-sphere. Int. Math. Res. Not. 1993, No. 9, 253–262 (1993)
283. Hofer, H., Toland, J.: Homoclinic, heteroclinic, and periodic orbits for a class of indefinite Hamiltonian systems. Math. Ann. 268, 387–403 (1984)
284. Hofer, H., Wysocki, K., Zehnder, E.: The dynamics on three-dimensional strictly convex energy surfaces. Ann. Math. (2) 148, No. 1, 197–289 (1998)
285. Holmes, P. J., Marsden, J. E.: Melnikov's method and Arnold diffusion for perturbations of integrable Hamiltonian systems. J. Math. Phys. 23, 669–675 (1982)
286. Holmes, P., Marsden, J., Scheurle, J.: Exponentially small splittings of separatrices with applications of KAM theory and degenerate bifurcations. In: Hamiltonian Dynamical Systems, Proc. AMS–IMS–SIAM Jt. Summer Res. Conf. (Boulder/Color. 1987). Contemp. Math. 81 (1988), 213–244

287. Huang, D., Liu, Z.: On the persistence of lower-dimensional invariant hyperbolic tori for smooth Hamiltonian systems. *Nonlinearity* 13, No. 1, 189–202 (2000)
288. Huang, Q., Cong, F., Li, Y.: Persistence of hyperbolic invariant tori for Hamiltonian systems. *J. Differ. Equations* 164, No. 2, 355–379 (2000)
289. Huang, Q., Cong, F., Li, Y.: Persistence of elliptic invariant tori for Hamiltonian systems. *Nonlinear Anal., Theory Methods Appl.* 45, No. 2(A), 241–260 (2001)
290. Il'yashenko, Yu. S.: A steepness criterion for analytic functions. *Usp. Mat. Nauk* 41, No. 1(247), 193–194 (1986). Engl. transl.: *Russ. Math. Surv.* 41, No. 1, 229–230 (1986)
291. Il'yashenko, Yu. S.: Embedding theorems for local maps, slow–fast systems and bifurcation from Morse–Smale to Smale–Williams. In: Khovanskij, A. G. (ed.) et al. *Topics in Singularity Theory. V.I. Arnold's 60th Anniversary Collection*. Am. Math. Soc. Transl. 2. Ser. 180(34). American Mathematical Society, Providence, R. I. (1997), 127–139
292. Ishlinskij, A. Yu.: *Mechanics of Special Gyroscopic Systems*. Akad. Nauk UkrSSR, Kiev (1952), 430 pp. Engl. transl.: *Mechanics of Gyroscopic Systems*. Israel Program for Scientific Translations, Jerusalem (1965), 313 pp.
293. Ishlinskij, A. Yu.: *Orientation, Gyroscopes, and Inertial Navigation*. Nauka, Moscow (1976), 670 pp. French transl.: vol. 1, 2. Mir, Moscow (1984), 285 pp., 399 pp.
294. Ishlinskij, A. Yu.: *Classical Mechanics and Inertia Forces*. Nauka, Moscow (1987), 320 pp. (Russian)
295. Itin, A. P., Nejshtadt, A. I., Vasiliev, A. A.: Captures into resonance and scattering on resonance in dynamics of a charged relativistic particle in magnetic field and electrostatic wave. *Physica D* 141, No. 3–4, 281–296 (2000)
296. Jorba, À., Masdemont, J.: Dynamics in the center manifold of the collinear points of the restricted three-body problem. *Physica D* 132, No. 1–2, 189–213 (1999)
297. Jorba, À., Simó, C.: On the reducibility of linear differential equations with quasiperiodic coefficients. *J. Differ. Equations* 98, No. 1, 111–124 (1992)
298. Jorba, À., Villanueva, J.: On the normal behaviour of partially elliptic lower-dimensional tori of Hamiltonian systems. *Nonlinearity* 10, No. 4, 783–822 (1997)
299. Jorba, À., Villanueva, J.: On the persistence of lower dimensional invariant tori under quasi-periodic perturbations. *J. Nonlinear Sci.* 7, No. 5, 427–473 (1997)
300. van Kampen, N. G.: Elimination of fast variables. *Phys. Rep.* 124, No. 2, 69–160 (1985)
301. van Kampen, E. R., Wintner, A.: On a symmetrical canonical reduction of the problem of three bodies. *Am. J. Math.* 59, 153–166 (1937)
302. Kapitsa, P. L.: Dynamic stability of a pendulum for oscillating point of suspension. *Zh. Ehksper. Teor. Fiz.* 21, No. 5, 588–598 (1951) (Russian)
303. Kaplansky, I.: *An Introduction to Differential Algebra*. Actualites Scientifiques et Industrielles 1251. Publ. Inst. Math. Univ. Nancago. V. Hermann & Cie, Paris (1957), 62 pp.
304. Karapetyan, A. V.: On realizing nonholonomic constraints by viscous friction forces and Celtic stones stability. *Prikl. Mat. Mekh.* 45, No. 1, 42–51 (1981). Engl. transl.: *J. Appl. Math. Mech.* 45, No. 1, 30–36 (1982)

305. Kasuga, T.: On the adiabatic theorem for the Hamiltonian system of differential equations in the classical mechanics. I, II, III. Proc. Japan Acad. 37, 366–371, 372–376, 377–382 (1961)
306. Katok, A. B.: Spectral properties of dynamical systems with an integral invariant on the torus. Funkts. Anal. Prilozh. 1, No. 4, 46–56 (1967). Engl. transl.: Funct. Anal. Appl. 1, No. 4, 296–305 (1967)
307. Katok, S. B.: Bifurcation sets and integral manifolds in the problem of motion of a heavy rigid body. Usp. Mat. Nauk 27, No. 2, 126–133 (1972) (Russian)
308. Katok, A.: Entropy and closed geodesics. Ergodic Theory Dyn. Syst. 2, 339–365 (1982)
309. Kevorkian, J.: On a model for reentry roll resonance. SIAM J. Appl. Math. 26, 638–669 (1974)
310. Khajkin, S. Eh.: Mechanics. Gostekhizdat, Moscow–Leningrad (1947), 574 pp. (Russian)
311. Khapaev, M. M. On averaging in multifrequency systems. Dokl. Akad. Nauk SSSR 217, 1021–1024 (1974). Engl. transl.: Sov. Math., Dokl. 15, 1180–1184 (1974)
312. Kharlamov, M. P. Characteristic class of a bundle and the existence of a global Routh function. Funkts. Anal. Prilozh. 11, No. 1, 89–90 (1977). Engl. transl.: Funct. Anal. Appl. 11, 80–81 (1977)
313. Kharlamova-Zabelina, E. I.: Rapid rotation of a rigid body around a fixed point in the presence of a non-holonomic constraint. Vestn. Mosk. Univ., Ser. I Mat. Mekh. 1957, No. 6, 25–34 (1957) (Russian)
314. Klein, F.: Vorlesungen über Höhere Geometrie. Grundlehren der Mathematischen Wissenschaften in Einzeldarstellungen 22. J. Springer, Berlin (1926), 405 pp.
315. Klingenberg, W.: Lectures on Closed Geodesics. Grundlehren der Mathematischen Wissenschaften 230. Springer-Verlag, Berlin–Heidelberg–New York (1978), 227 pp.
316. Kochergin, A. V.: On the absence of mixing in special flows over the rotation of a circle and in flows on a two-dimensional torus. Dokl. Akad. Nauk SSSR 205, 515–518 (1972). Engl. transl.: Sov. Math., Dokl. 13, 949–952 (1972)
317. Kolmogorov, A. N.: On dynamical systems with an integral invariant on the torus. Dokl. Akad. Nauk SSSR 93, 763–766 (1953) (Russian)
318. Kolokol'tsov, V. N.: Geodesic flows on two-dimensional manifolds with an additional first integral that is polynomial in the velocities. Izv. Akad. Nauk SSSR, Ser. Mat. 46, No. 5, 994–1010 (1982). Engl. transl.: Math. USSR, Izv. 21, 291–306 (1983)
319. Kovalev, A. M., Savchenko, A. Ya.: Stability of uniform rotations of a rigid body about a principal axis. Prikl. Mat. Mekh. 39, No. 4, 650–660 (1975). Engl. transl.: J. Appl. Math. Mech. 39, No. 4, 623–633 (1975)
320. Koval'ev, A. M., Chudnenko, A. N., Chudnenko, O. M.: On the stability of the equilibrium of a two-dimensional Hamiltonian system in case of equal frequencies. Dopov. Akad. Nauk Ukr. RSR, Ser. A 1977, 1010–1013 (1977) (Ukrainian)
321. Kozai, Y.: Secular perturbations of asteroids with high inclination and eccentricity. Astron. J. 67, No. 9, 591–598 (1962)
322. Kozlov, V. V.: The principle of least action and periodic solutions in problems of classical mechanics. Prikl. Mat. Mekh. 40, No. 3, 399–407 (1976). Engl. transl.: J. Appl. Math. Mech. 40, No. 3, 363–370 (1976)

323. Kozlov, V. V.: On the geometry of domains of possible motions with boundary. *Vestn. Mosk. Univ., Ser. I Mat. Mekh.* 1977, No. 5, 118–120 (1977). Engl. transl.: *Mosc. Univ. Mech. Bull.* 32, No. 5–6, 23–25 (1977)
324. Kozlov, V. V.: Nonexistence of univalued integrals and branching of solutions in rigid body dynamics. *Prikl. Mat. Mekh.* 42, No. 3, 400–406 (1978). Engl. transl.: *J. Appl. Math. Mech.* 42, No. 3, 420–426 (1979)
325. Kozlov, V. V.: Periodic oscillations of a composite pendulum. *Prikl. Mat. Mekh.* 44, No. 2, 238–244 (1980). Engl. transl.: *J. Appl. Math. Mech.* 44, No. 2, 170–173 (1981)
326. Kozlov, V. V.: On the instability of equilibrium in a potential field. *Usp. Mat. Nauk* 36, No. 3, 215–216 (1981). Engl. transl.: *Russ. Math. Surv.* 36, No. 3, 256–257 (1981).
327. Kozlov, V. V.: Equilibrium instability in a potential field, taking account of viscous friction. *Prikl. Mat. Mekh.* 45, No. 3, 570–572 (1981). Engl. transl.: *J. Appl. Math. Mech.* 45, No. 3, 417–418 (1982)
328. Kozlov, V. V.: Asymptotic solutions of equations of classical mechanics. *Prikl. Mat. Mekh.* 46, No. 4, 573–577 (1982). Engl. transl.: *J. Appl. Math. Mech.* 46, No. 4, 454–457 (1983)
329. Kozlov, V. V.: Dynamics of systems with non-integrable constraints. I–VI. *Vestn. Mosk. Univ., Ser. I Mat. Mekh.* 1982, No. 3, 92–100 (1982); 1982, No. 4, 70–76 (1982); 1983, No. 3, 102–111 (1983); 1987, No. 5, 76–83 (1987); 1988, No. 6, 51–54 (1988). Engl. transl.: *Mosc. Univ. Mech. Bull.* 37, No. 3–4, 27–34 (1982); 37, No. 3–4, 74–80 (1982); 38, No. 3, 40–51 (1983); 42, No. 5, 40–49 (1987); 43, No. 6, 23–29 (1988)
330. Kozlov, V. V.: The hydrodynamics of Hamiltonian systems. *Vestn. Mosk. Univ., Ser. I Mat. Mekh.* 1983, No. 6, 10–22 (1983). Engl. transl.: *Mosc. Univ. Mech. Bull.* 38, No. 6, 9–23 (1983).
331. Kozlov, V. V.: Realization of nonintegrable constraints in classical mechanics. *Dokl. Akad. Nauk SSSR* 272, 550–554 (1983). Engl. transl.: *Sov. Phys., Dokl.* 28, 735–737 (1983)
332. Kozlov, V. V.: On the theory of integration of the equations of nonholonomic mechanics. *Usp. Mekh.* 8, No. 3, 85–107 (1985) (Russian)
333. Kozlov, V. V.: Asymptotic motions and the inversion of the Lagrange–Dirichlet theorem. *Prikl. Mat. Mekh.* 50, No. 6, 928–937 (1986). Engl. transl.: *J. Appl. Math. Mech.* 50, No. 6, 719–725 (1986)
334. Kozlov, V. V.: On the existence of an integral invariant of a smooth dynamical system. *Prikl. Mat. Mekh.* 51, No. 4, 538–545 (1987). Engl. transl.: *J. Appl. Math. Mech.* 51, No. 4, 420–426 (1987)
335. Kozlov, V. V.: Invariant measures of Euler–Poincaré equations on Lie algebras. *Funkts. Anal. Prilozh.* 22, No. 1, 69–70 (1988). Engl. transl.: *Funct. Anal. Appl.* 22, No. 1, 58–59 (1988)
336. Kozlov, V. V.: On the symmetry groups of dynamical systems. *Prikl. Mat. Mekh.* 52, No. 4, 531–541 (1988). Engl. transl.: *J. Appl. Math. Mech.* 52, No. 4, 413–420 (1988)
337. Kozlov, V. V.: Vortex theory of a top. *Vestn. Mosk. Univ., Ser. I Mat. Mekh.* 1990, No. 4, 56–62 (1990). Engl. transl.: *Eddy theory of the top. Mosc. Univ. Mech. Bull.* 45, No. 4, 26–38 (1990)
338. Kozlov, V. V.: Groups of symmetries of geodesic flows on closed surfaces. *Mat. Zametki* 48, No. 5, 62–67 (1990). Engl. transl.: *Math. Notes* 48, No. 5, 1119–1122 (1990)

339. Kozlov, V. V.: Tensor invariants of quasihomogeneous systems of differential equations, and the Kovalevskaya–Lyapunov asymptotic method. *Mat. Zametki* 51, No. 2, 46–52 (1992). Engl. transl.: *Math. Notes* 51, No. 2, 138–142 (1992)
340. Kozlov, V. V.: The Liouville property of invariant measures of completely integrable systems and the Monge–Ampère equation. *Mat. Zametki* 53, No. 4, 45–52 (1993). Engl. transl.: *Math. Notes* 53, No. 4, 389–393 (1993)
341. Kozlov, V. V.: On the degree of instability. *Prikl. Mat. Mekh.* 57, No. 5, 14–19 (1993). Engl. transl.: *J. Appl. Math. Mech.* 57, No. 5, 771–776 (1993)
342. Kozlov, V. V.: Dynamical systems determined by the Navier–Stokes equations. *Russ. J. Math. Phys.* 1, No. 1, 57–69 (1993)
343. Kozlov, V. V.: Dynamics in spaces of constant curvature. *Vestn. Mosk. Univ., Ser. I Mat. Mekh.* 1994, No. 2, 28–35 (1994). Engl. transl.: *Mosc. Univ. Math. Bull.* 49, No. 2, 21–28 (1994)
344. Kozlov, V. V.: Integral invariants of the Hamiltonian equations. *Mat. Zametki* 58, No. 3, 379–393 (1995). Engl. transl.: *Math. Notes* 58, No. 3, 938–947 (1995)
345. Kozlov, V. V.: On motion of a disc on an inclined plane. *Izv. Ross. Akad. Nauk, Mekh. Tverd. Tela* 1996, No. 5, 29–35 (1996) (Russian)
346. Kozlov, V. V.: Closed orbits and chaotic dynamics of a charged particle in a periodic electromagnetic field. *Regul. Khaoticheskaya Din.* 2, No. 1, 3–12 (1997). Engl. transl.: *Regul. Chaotic Dyn.* 2, No. 1, 3–12 (1997)
347. Kozlov, V. V.: On stabilization of charge unstable equilibria by strong magnetic fields. *Prikl. Mat. Mekh.* 61, No. 3, 390–397 (1997). Engl. transl.: *J. Math. Appl. Mekh.* 61, No. 3, 377–384 (1997)
348. Kozlov, V. V.: The frozen-in condition for a direction field, small denominators and chaotization of steady flows of a viscous liquid. *Prikl. Mat. Mekh.* 63, No. 2, 237–244 (1999). Engl. transl.: *J. Appl. Math. Mech.* 63, No. 2, 229–235 (1999)
349. Kozlov, V. V.: The Newton and Ivory theorems of attraction in spaces of constant curvature. *Vestn. Mosk. Univ., Ser. I Mat. Mekh.* 2000, No. 5, 43–47 (2000). Engl. transl.: *Mosc. Univ. Mech. Bull.* 55, No. 5, 16–20 (2000)
350. Kozlov, V. V., Furta, S. D.: *Asymptotic Expansions of Solutions of Strongly Nonlinear Systems of Differential Equations.* Moscow Univ., Moscow (1996), 244 pp. (Russian)
351. Kozlov, V. V., Harin, A. O.: Kepler’s problem in constant curvature spaces. *Celestial Mech. Dyn. Astron.* 54, No. 4, 393–399 (1992)
352. Kozlov, V. V., Kharin, A. O.: Relativity principle and inertia forces. *Sbornik Nauchn.-Metod. Stat. Teoret. Mekh.* 1999, No. 21, 16–23 (1999) (Russian)
353. Kozlov, V. V., Kolesnikov, N. N.: On theorems of dynamics. *Prikl. Mat. Mekh.* 42, No. 1, 28–33 (1978). Engl. transl.: *J. Appl. Math. Mech.* 42, No. 1, 26–31 (1979)
354. Kozlov, V. V., Kolesnikov, N. N.: On the integrability of Hamiltonian systems. *Vestn. Mosk. Univ., Ser. I Mat. Mekh.* 1979, No. 6, 88–91 (1979). Engl. transl.: *Mosc. Univ. Mech. Bull.* 34, No. 5–6, 48–51 (1979)
355. Kozlov, V. V., Nejshtadt, A. I.: On the realization of holonomic constraints. *Prikl. Mat. Mekh.* 54, No. 5, 858–861 (1990). Engl. transl.: *J. Appl. Math. Mech.* 54, No. 5, 705–708 (1990)
356. Kozlov, V. V., Onishchenko, D. A.: Nonintegrability of Kirchhoff’s equations. *Dokl. Akad. Nauk SSSR* 266, 1298–1300 (1982). Engl. transl.: *Sov. Math., Dokl.* 26, 495–498 (1982)

357. Kozlov, V. V., Palamodov, V. P.: On asymptotic solutions of the equations of classical mechanics. *Dokl. Akad. Nauk SSSR* 263, 285–289 (1982). Engl. transl.: *Sov. Math., Dokl.* 25, 335–339 (1982)
358. Kozlov, V. V., Yaroshchuk, V. A.: On the invariant measures of Euler–Poincaré equations on unimodular groups. *Vestn. Mosk. Univ., Ser. I Mat. Mekh.* 1993, No. 2, 91–95 (1993). Engl. transl.: *Mosc. Univ. Mech. Bull.* 48, No. 2, 45–50 (1993)
359. Kravtsov, Yu. A., Orlov, Yu. I.: *Geometrical Optics of Inhomogeneous Media*. Nauka, Moscow (1980), 304 pp. Engl. transl.: Springer Series on Wave Phenomena 6. Springer-Verlag, Berlin (1990), 312 pp.
360. Krylov, N. M., Bogolyubov, N. N.: Application of methods of non-linear mechanics to the theory of stationary oscillations. In: Bogolyubov, N. N. *Selected Works*, I. Naukova Dumka, Kiev (1969), 257–337. Engl. transl.: Bogolyubov, N. N.: *Selected Works. Part I. Dynamical Theory. Classics of Soviet Mathematics 2*. Gordon and Breach Science Publishers, New York (1990), 386 pp.
361. Kuksin, S. B.: On the inclusion of an almost integrable analytic symplectomorphism into a Hamiltonian flow. *Russ. J. Math. Phys.* 1, No. 2, 191–207 (1993)
362. Kuksin, S., Pöschel, J.: On the inclusion of analytic symplectic maps in analytic Hamiltonian flows and its applications. In: Kuksin, S. (ed.) et al. *Seminar on Dynamical Systems*. Euler International Mathematical Institute (St. Petersburg, Russia, 1991). *Prog. Nonlinear Differ. Equ. Appl.* 12. Birkhäuser, Basel (1994), 96–116
363. Kuz'mina, R. P.: Bifurcation set in the problem of motion of a heavy rigid body with a fixed point. *Izv. Akad. Nauk SSSR, Mekh. Tverd. Tela* 17, No. 1, 3–10 (1982) (Russian)
364. Kuznetsov, A. N.: Existence of solutions entering at a singular point of an autonomous system having a formal solution. *Funkts. Anal. Prilozh.* 23, No. 4, 63–74 (1989). Engl. transl.: *Funct. Anal. Appl.* 23, No. 4, 308–317 (1989)
365. Laloy, M.; Pfeiffer, K. On the instability of equilibrium when the potential has a non-strict local minimum. *Arch. Ration. Mech. Anal.* 78, 213–222 (1982)
366. Lamb, H.: *Hydrodynamics*. University Press, Cambridge (1932), 738 pp.
367. Landau, L. D., Lifshits, E. M.: *Course of Theoretical Physics. Vol. 1: Mechanics*. Nauka, Moscow (1988), 216 pp. Engl. transl.: Addison-Wesley, Reading MA (1960), 165 pp.
368. Landau, L. D., Lifshits, E. M.: *Course of Theoretical Physics. Vol. 3: Quantum Mechanics. Non-Relativistic Theory*. Nauka, Moscow (1988), 768 pp. Engl. transl.: Addison-Wesley, Reading MA (1958), 515 pp.
369. Lazutkin, V. F.: To Moser's theorem on invariant curves. *Vopr. Dinamich. Teor. Rasprostr. Seism. Voln.* 14, 109–120 (1974) (Russian)
370. Lazutkin, V. F.: *Convex Billiards and Eigenfunctions of the Laplace Operator*. Leningrad Univ., Leningrad (1981), 196 pp. (Russian)
371. Lazutkin, V. F.: Splitting of separatrices of the standard Chirikov map. *Dep. VINITI* 24.09.84, No. 6372–84, Moscow (1984). Revised Engl. transl.: *Math. Phys. Preprint Archive* 98-421 (1998), www.ma.utexas.edu/mp_arc
372. Lazutkin, V. F.: The width of the instability zone around separatrices of a standard mapping. *Dokl. Akad. Nauk SSSR* 313, No. 2, 268–272 (1990). Engl. transl.: *Soviet Math. Dokl.* 42, No. 1, 5–9 (1991)
373. Lazutkin, V. F., Schachmannski, I. G., Tabanov, M. B.: Splitting of separatrices for standard and semistandard mappings. *Physica D* 40, No. 2, 235–248 (1989)

374. Lee, H.-Ch.: The universal integral invariants of Hamiltonian systems and application to the theory of canonical transformations. *Proc. R. Soc. Edinb., Sect. A* 62, 237–246 (1947)
375. Lenard, A.: Adiabatic invariance to all orders. *Ann. Phys.* 6, 261–276 (1959)
376. Leontovich, A. M.: On the stability of the Lagrange periodic solution for the restricted problem of three bodies. *Dokl. Akad. Nauk SSSR* 143, 525–528 (1962). Engl. transl.: *Sov. Math., Dokl.* 3, 425–429 (1962)
377. Levi, M.: Adiabatic invariants of the linear Hamiltonian systems with periodic coefficients. *J. Differ. Equations* 42, 47–71 (1981)
378. Li, Y., Yi, Y.: A quasi-periodic Poincaré’s theorem. *Math. Ann.* 326, No. 4, 649–690 (2003)
379. Li, Y., Yi, Y.: On Poincaré–Treshchev tori in Hamiltonian systems. In: Dumortier, F. (ed.) et al. *EQUADIFF 2003. Proc. Conf. (Hasselt/Diepenbeek, Netherlands, 2003)*. World Scientific, Hackensack, N. J. (2005), 136–151
380. Li, Y., Yi, Y.: Persistence of hyperbolic tori in Hamiltonian systems. *J. Differ. Equations* 208, No. 2, 344–387 (2005)
381. Li, Y., Yi, Y.: Persistence of lower dimensional tori of general types in Hamiltonian systems. *Trans. Am. Math. Soc.* 357, No. 4, 1565–1600 (2005)
382. Lidov, M. L.: Evolution of orbits of artificial satellites of planets under the action of gravitational perturbations of external bodies. *Iskusstv. Sputniki Zemli* 8, 5–45 (1961). Engl. transl.: *AIAA J.* 1, 1985–2002 (1963)
383. Lidov, M. L.: On approximate analysis of evolution of orbits of artificial satellites. In: *Problems of Motion of Artificial Celestial Bodies*. Akad. Nauk SSSR, Moscow (1963), 119–134 (Russian)
384. Lidov, M. L., Vashkov’yak, M. A., Markeev A. P.: Semi-analytic method of calculating the motion of cosmic apparatus in a neighbourhood of a collinear libration point. *Kosmich. Issled.* 14, No. 6, 909–921 (1976) (Russian)
385. Lidov, M. L., Ziglin, S. L.: The analysis of restricted circular twice-averaged three body problem in the case of close orbits. *Celest. Mech.* 9, 151–173 (1974)
386. Lifshits, I. M., Slutskin, A. A., Nabutovskij, V. M.: Motion of charged quasi-particles in a varying inhomogeneous electromagnetic field. *Zh. Ekhsper. Teor. Fiz.* 41, 939–948 (1961). Engl. transl.: *Sov. Phys., JETP* 14, 669–675 (1962)
387. Lifshits, I. M., Slutskin, A. A., Nabutovskij, V. M.: On the phenomenon of scattering of charged quasi-particles at singular points in a p -space. *Dokl. Akad. Nauk SSSR* 137, No. 3, 553–556 (1961) (Russian)
388. Lindstedt, A.: Beitrag zur Integration der Differentialgleichungen der Störungstheorie. *Voss’ Sortiment, Petersburg und Leipzig* (1883). *Memoires de l’Académie Impériale des Sciences de St.-Pétersbourg*, VII^e série, 31, No. 4, 1–20 (1883)
389. Littlejohn, R. G.: *Hamiltonian Theory of Guiding Center Motion*. Lawrence Berkeley Lab., Berkeley (1980), 224 pp.
390. Liu, Zh.: Persistence of lower dimensional invariant tori on sub-manifolds in Hamiltonian systems. *Nonlinear Anal., Theory Methods Appl.* 61, No. 8 (A), 1319–1342 (2005)
391. de la Llave, R.: On necessary and sufficient conditions for uniform integrability of families of Hamiltonian systems. In: Ledrappier, F. (ed.) et al. *Proc. 1st Int. Conf. on Dynamical Systems (Montevideo, Uruguay, 1995)*. Pitman Res. Notes Math. Ser. 362. Longman, Harlow (1996), 76–109

392. de la Llave, R.: A tutorial on KAM theory. In: Katok, A. (ed.) et al., Smooth Ergodic Theory and its Applications. Proc. AMS Summer Res. Inst. (Seattle, WA, 1999). Proc. Symp. Pure Math. 69. American Mathematical Society, Providence, R. I. (2001), 175–292
393. de la Llave, R., Wayne, C. E.: Whiskered and low dimensional tori in nearly integrable Hamiltonian systems. Math. Phys. Electron. J. 10, Paper No.5, 45 pp. (2004)
394. Llibre, J., Simó, C.: Oscillatory solutions in the planar restricted three-body problem. Math. Ann. 248, 153–184 (1980)
395. Lochak, P.: Canonical perturbation theory via simultaneous approximation Usp. Mat. Nauk 47, No. 6, 59–140 (1992); Erratum: 48, No. 1, 224 (1993). Engl. transl.: Russ. Math. Surv. 47, No. 6, 57–133 (1992)
396. Lochak, P., Marco, J.-P.: Diffusion times and stability exponents for nearly integrable analytic systems. Cent. Eur. J. Math. 3, No. 3, 342–397 (electronic) (2005)
397. Lochak, P., Meunier, C.: Multiphase Averaging for Classical Systems. With Applications to Adiabatic Theorems. Applied Mathematical Sciences 72. Springer-Verlag, New York etc. (1988), 360 pp.
398. Lochak, P., Nejshtadt, A. I.: Estimates of stability time for nearly integrable systems with a quasiconvex Hamiltonian. Chaos 2, No. 4, 495–499 (1992)
399. Long, Y.: Dynamics on compact convex hypersurfaces in \mathbb{R}^{2n} . In: Chang, K.-Ch. (ed.) et al. Progress in Nonlinear Analysis. Proc. Second Int. Conf. Nonlinear Analysis (Tianjin, China, 1999). Nankai Ser. Pure Appl. Math. Theor. Phys. 6. World Scientific, Singapore(2000), 271–288.
400. Lyapunov, A. M.: On one property of differential equations of the problem on the motion of a heavy rigid body having a fixed point. In: Lyapunov, A. M. Collected Works, Vol. I. Akad. Nauk SSSR, Moscow (1954), 409–417 (Russian)
401. Mach, E.: The Science of Mechanics: A Critical and Historical Account of its Development. The Open Court Publishing Co., La Salle, Ill. (1960), 634 pp.
402. MacKay, R. S., Meiss, J. D., Percival, I. C.: Transport in Hamiltonian Systems. Queen Mary College, London (1983), 81 pp.
403. Malykhin, G. B., Nejmark, Yu. I.: Non-holonomicity of a constraint of a state of electromagnetic fields in one-mode light-guide with linear two-ray refraction and angles of its torsion. Izv. VUZ., Radiofizika 41, No. 9, 1125–1136 (1998) (Russian)
404. Mañé, R.: On the minimizing measures of Lagrangian dynamical systems. Nonlinearity 5, No. 3, 623–638 (1992)
405. Marco, J.-P.: Transition le long des chaînes de tores invariants pour les systèmes hamiltoniens analytiques. Ann. Inst. Henri Poincaré, Phys. Théor. 64, No. 2, 205–252 (1996)
406. Marco, J.-P., Sauzin, D.: Stability and instability for Gevrey quasi-convex near-integrable Hamiltonian systems. Publ. Math., Inst. Hautes Étud. Sci. 96, 199–275 (2002)
407. Marco, J.-P., Sauzin, D.: Wandering domains and random walks in Gevrey near-integrable systems. Ergodic Theory Dyn. Syst. 24, No. 5, 1619–1666 (2004)
408. Markeev, A. P.: Libration Points in Celestial Mechanics and Cosmodynamics. Nauka, Moscow (1978), 312 pp. (Russian)
409. Markeev, A. P.: The Dynamics of a Body Contiguous to a Solid Surface. Nauka, Moscow (1992), 336 pp. (Russian)

410. Markeev, A. P.: On spherical pendulum with vibrating point of suspension. In: Furta, S. D. (ed.) *Topical Problems of Classical and Celestial Mechanics*. Elf, Moscow (1998), 102–114 (Russian)
411. Marsden, J., Weinstein, A.: Reduction of symplectic manifolds with symmetry. *Rep. Math. Phys.* 5, 121–130 (1974)
412. Mather, J. N.: Concavity of the Lagrangian for quasi-periodic orbits. *Comment. Math. Helv.* 57, 356–376 (1982)
413. Mather, J. N.: Existence of quasi-periodic orbits for twist homeomorphisms of the annulus. *Topology* 21, 457–467 (1982)
414. Mather, J. N.: A criterion for the non-existence of invariant circles. *Publ. Math., Inst. Hautes Étud. Sci.* 63, 153–204 (1986)
415. Mather, J. N.: Action minimizing invariant measures for positive definite Lagrangian systems. *Math. Z.* 207, No. 2, 169–207 (1991)
416. Mather, J. N.: Variational construction of connecting orbits. *Ann. Inst. Fourier* 43, No. 5, 1349–1386 (1993)
417. Mather, J. N.: Talk given at the conference on dynamical systems, Oberwolfach (1997)
418. Mather, J. N.: Arnold diffusion. I: Announcement of results. *J. Math. Sci.* 124, No. 5, 5275–5289 (2004)
419. Mather, J. N., McGehee, R.: Solutions of the collinear four body problem which become unbounded in finite time. In: *Dyn. Syst., Theor. Appl., Battelle Seattle 1974 Renc., Lect. Notes Phys.* 38 (1975), 573–597
420. Mel'nikov, V. K.: On the stability of the center for time-periodic perturbations. *Tr. Mosk. Mat. O.-va* 12, 3–52 (1963). Engl. transl.: *Trans. Mosc. Math. Soc.* 12, 1–56 (1963)
421. Mel'nikov, V. K.: On some cases of conservation of conditionally periodic motions under a small change of the Hamiltonian function. *Dokl. Akad. Nauk SSSR* 165, 1245–1248 (1965). Engl. transl.: *Sov. Math., Dokl.* 6, 1592–1596 (1965)
422. Mel'nikov, V. K.: A family of conditionally periodic solutions of a Hamiltonian system. *Dokl. Akad. Nauk SSSR* 181, 546–549 (1968). Engl. transl.: *Sov. Math., Dokl.* 9, 882–886 (1968)
423. Milnor, J. W.: *Morse Theory*. *Annals of Mathematics Studies* 51. Princeton University Press, Princeton, N. J. (1963), 153 pp.
424. Mishchenko, A. S., Fomenko, A. T.: Generalized Liouville method of integration of Hamiltonian systems. *Funkts. Anal. Prilozh.* 12, No. 2, 46–56 (1978). Engl. transl.: *Funct. Anal. Appl.* 12, 113–121 (1978)
425. Mishchenko, A. S., Fomenko, A. T.: Integration of Hamiltonian systems with non-commutative symmetries. *Tr. Sem. Vekt. Tensor Analiz Prilozh. Geom. Mekh. Fiz.* 20, 5–54 (1980) (Russian)
426. Mitropol'skij, Yu. A.: *Averaging Method in Nonlinear Mechanics*. Naukova Dumka, Kiev (1971), 440 pp. (Russian)
427. Mitropol'skij, Yu. A., Lykova, O. B.: *Integral Manifolds in Nonlinear Mechanics*. Nauka, Moscow (1973), 512 pp. (Russian)
428. Moiseev, A. V., Nejshtadt, A. I.: Phase portraits of Lorenz system for large Rayleigh numbers. *Izv. Ross. Akad. Nauk, Mekh. Tverd. Tela* 1995, No. 4, 23–30 (1995) (Russian)
429. Moltchanov, A. M.: The resonant structure of the Solar System. *Icarus* 8, No. 2, 203–215 (1968)

430. Montgomery, R.: The connection whose holonomy is the classical adiabatic angles of Hannay and Berry and its generalization to the nonintegrable case. *Comm. Math. Phys.* 120, No. 2, 269–294 (1988)
431. Moore, C. Braids in classical dynamics. *Phys. Rev. Lett.* 70, No. 24, 3675–3679 (1993)
432. Morbidelli, A., Giorgilli, A.: Superexponential stability of KAM tori. *J. Stat. Phys.* 78, No. 5–6, 1607–1617 (1995)
433. Morozov, A. D.: A complete qualitative investigation of Duffing’s equation. *Differ. Uravn.* 12, No. 2, 241–255 (1976). Engl. transl.: *Differ. Equations* 12, 164–174 (1977)
434. Morse, H. M.: A fundamental class of geodesics on any closed surface of genus greater than one. *Trans. Am. Math. Soc.* 26, 25–60 (1924)
435. Moser, J.: The analytic invariants of an area preserving mapping near a hyperbolic fixed point. *Commun. Pure Appl. Math.* 9, 673–692 (1956)
436. Moser, J.: On invariant curves of area-preserving mappings of an annulus. *Nachr. Akad. Wiss. Göttingen, II. Math.-Phys. Kl.* 1962, 1–20 (1962)
437. Moser, J.: Combination tones for Duffing’s equation. *Commun. Pure Appl. Math.* 18, 167–181 (1965)
438. Moser, J.: A rapidly convergent iteration method and non-linear partial differential equations. I, II. *Ann. Sc. Norm. Super. Pisa, Sci. Fis. Mat., III. Ser.* 20, 265–315, 499–535 (1966)
439. Moser, J.: On the construction of almost periodic solutions for ordinary differential equations. In: *Proc. Int. Conf. on Functional Analysis and Related Topics (Tokyo, 1969)*. Univ. of Tokyo Press, Tokyo (1970), 60–67
440. Moser, J.: Three integrable Hamiltonian systems connected with isospectral deformations. *Adv. Math.* 16, 197–220 (1975)
441. Moser, J.: Remark on the paper “On invariant curves of area-preserving mappings of an annulus”. *Regul. Chaotic Dyn.* 6, No. 3, 337–338 (2001)
442. Morse, P. M., Feshbach, H.: *Methods of Theoretical Physics*. Vol. I, II. McGraw-Hill, New York (1953), 1978 pp.
443. Moshchevitin, N. G.: On a theorem of Poincaré. *Usp. Mat. Nauk* 53, No. 1, 223–224 (1998). Engl. transl.: *Russ. Math. Surv.* 53, No. 1, 219–220 (1998)
444. Murdock, J.: Qualitative theory of nonlinear resonance by averaging and dynamical systems methods. *Dyn. Rep.* 1, 91–172 (1988)
445. Nambu, Y.: Generalized Hamiltonian dynamics. *Phys. Rev. D(3)* 7, 2405–2412 (1973)
446. Nash, J.: The imbedding problem for Riemannian manifolds. *Ann. Math. (2)* 63, 20–63 (1956)
447. Nejshtadt, A. I.: On Some Resonance Problems in Nonlinear Systems. Kandidat Diss. Moscow Univ., Moscow (1975), 150 pp. (Russian)
448. Nejshtadt, A. I.: Passage through a resonance in the two-frequency problem. *Dokl. Akad. Nauk SSSR* 221, 301–304 (1975). Engl. transl.: *Sov. Phys., Dokl.* 20, 189–191 (1975)
449. Nejshtadt, A. I.: Stability of plane solutions in the doubly averaged restricted circular three-body problem. *Pis’ma Astron. Zh.* 1, No. 10, 41–45 (1975). Engl. transl.: *Sov. Astron. Lett.* 1, 211–213 (1975)
450. Nejshtadt, A. I.: Passage through a separatrix in a resonance problem with a slowly-varying parameter. *Prikl. Mat. Mekh.* 39, No. 4, 621–632 (1975). Engl. transl.: *J. Appl. Math. Mech.* 39, No. 4, 594–605 (1975)

451. Nejshtadt, A. I.: Averaging in multifrequency systems. II. Dokl. Akad. Nauk SSSR 226, 1295–1298 (1976). Engl. transl.: Sov. Phys., Dokl. 21, 80–82 (1976)
452. Nejshtadt, A. I.: On the evolution of rotation of a rigid body under the action of a sum of a constant and a dissipative perturbing moments. Izv. Akad. Nauk SSSR, Mekh. Tverd. Tela 1980, No. 6, 30–36 (1980) (Russian)
453. Nejshtadt, A. I.: On the accuracy of conservation of the adiabatic invariant. Prikl. Mat. Mekh. 45, No. 1, 80–87 (1981). Engl. transl.: J. Appl. Math. Mech. 45, No. 1, 58–63 (1982)
454. Nejshtadt, A. I.: Estimates in the Kolmogorov theorem on conservation of conditionally periodic motions. Prikl. Mat. Mekh. 45, No. 6, 1016–1025 (1981). Engl. transl.: J. Appl. Math. Mech. 45, No. 6, 766–772 (1982)
455. Nejshtadt, A. I.: The separation of motions in systems with rapidly rotating phase. Prikl. Mat. Mekh. 48, No. 2, 197–204 (1984). Engl. transl.: J. Appl. Math. Mech. 48, No. 2, 133–139 (1985)
456. Nejshtadt, A. I.: Change of an adiabatic invariant at a separatrix. Fiz. Plazmy 12, No. 8, 992–1000 (1986). Engl. transl.: Sov. J. Plasma Phys. 12, 568–573 (1986)
457. Nejshtadt, A. I.: On the change in the adiabatic invariant on crossing a separatrix in systems with two degrees of freedom. Prikl. Mat. Mekh. 51, No. 5, 750–757 (1987). Engl. transl.: J. Appl. Math. Mech. 51, No. 5, 586–592 (1987)
458. Nejshtadt, A. I.: Jumps in the adiabatic invariant on crossing the separatrix and the origin of the 3:1 Kirkwood gap. Dokl. Akad. Nauk SSSR 295, 47–50 (1987). Engl. transl.: Sov. Phys., Dokl. 32, 571–573 (1987)
459. Nejshtadt, A. I.: Problems of Perturbation Theory for Nonlinear Resonant Systems. Doktor Diss. Moscow Univ., Moscow (1989), 342 pp. (Russian)
460. Nejshtadt, A. I.: On probabilistic phenomena in perturbed systems. In: Bazykin, A. (ed.) et al. Mathematics and Modelling. NTsBI Akad. Nauk SSSR, Pushchino (1990), 141–155. Engl. transl.: Selecta Math. Sov. 12, No. 3, 195–210 (1993)
461. Nejshtadt, A. I.: On destruction of adiabatic invariants in multi-frequency systems. In: Perelló, C. (ed.) et al. Proc. Int. Conf. on Differential Equations EQUADIFF 91 (Barcelona, Spain, 1991). Vol. 1, 2. World Scientific, Singapore (1993), 195–207
462. Nejshtadt, A. I.: Scattering by resonances. Celest. Mech. Dyn. Astron. 65, No. 1–2, 1–20 (1997)
463. Nejshtadt, A. I.: On adiabatic invariance in two-frequency systems. In: Simó, C. (ed.) Hamiltonian Systems with Three or More Degrees of Freedom. Proceedings of the NATO Advanced Study Institute, S'Agaró, Spain, June 19–30, 1995. NATO ASI Ser., Ser. C, Math. Phys. Sci. 533. Kluwer Academic Publishers, Dordrecht (1999), 193–212
464. Nejshtadt, A. I.: Capture into resonance and scattering on resonances in two-frequency systems. Tr. Mat. Inst. Steklova 250, 198–218 (2005). Engl. transl.: Proc. Steklov Inst. Math. 250, 183–203 (2005)
465. Nejshtadt, A. I., Pivovarov, M. L.: On Evolution of Rotation ASE under the Action of a Perturbing Moment Constant in Attached Axes. Preprint No. 434, Inst. Kosmich. Issled. Akad. Nauk SSSR, Moscow (1978), 9 pp. (Russian)
466. Nejshtadt, A. I., Sidorenko, V. V., Treshchev, D. V.: Stable periodic motions in the problem on passage through a separatrix. Chaos 7, No. 1, 2–11 (1997)

467. Nejshtadt, A. I., Timofeev, A. V.: Phenomenon of autoresonance under electron cyclotron heating of plasma. *Zh. Ehksper. Teor. Fiz.* 93, No. 5, 1706–1713 (1987). Engl. transl.: *Sov. Phys., JETP* 66, 973–977 (1987)
468. Nejshtadt, A. I., Vainshtein, D. L., Vasiliev, A. A.: Chaotic advection in a cubic Stokes flow. *Physica D* 111, No. 1–4, 227–242 (1998)
469. Nejshtadt, A. I., Vasiliev, A. A.: Change of the adiabatic invariant at a separatrix in a volume-preserving 3D system. *Nonlinearity* 12, No. 2, 303–320 (1999)
470. Nejshtadt, A. I., Vasiliev, A. A.: Phase change between separatrix crossings in slow–fast Hamiltonian systems. *Nonlinearity* 18, No. 3, 1393–1406 (2005)
471. Nekhoroshev, N. N.: Action–angle variables and their generalizations. *Tr. Mosk. Mat. O-va* 26, 181–198 (1972). Engl. transl.: *Trans. Mosc. Math. Soc.* 26, 180–198 (1972)
472. Nekhoroshev, N. N.: Method of successive canonical changes of variables. Supplement in: Moser, J. *Lectures on Hamiltonian Systems* (Russian transl.) Mir, Moscow (1973), 150–164 (Russian)
473. Nekhoroshev, N. N.: Stable lower estimates for smooth maps and for gradients of smooth functions. *Mat. Sb.* 90, 432–478 (1973). Engl. transl.: *Math. USSR, Sb.* 19, No. 3, 425–467 (1973)
474. Nekhoroshev, N. N.: An exponential estimate of the time of stability of nearly integrable Hamiltonian systems. II. *Tr. Semin. Im. I. G. Petrovskogo* 5, 5–50 (1979). Engl. transl.: *Topics in modern mathematics, Petrovskii Semin.* 5, 1–58 (1985)
475. Nemytskij, V. V., Stepanov, V. V.: *Qualitative Theory of Differential Equations*. OGIZ, Moscow–Leningrad (1947), 448 pp. Engl. transl.: Princeton Univ. Press, Princeton, N.J. (1960), 523 pp.
476. Newcomb, S.: On the general integrals of planetary motion. *Smithsonian Contributions to Knowledge* 281, 1–31 (1874)
477. Newton, I., Bernoulli, D., d’Arcy, P.: *Abhandlungen über jene Grundsätze der Mechanik, die Integrale der Differentialgleichungen liefern*. W. Engelmann, Leipzig–Berlin (1914), 110 pp.
478. Niederman, L.: Stability over exponentially long times in the planetary problem. *Nonlinearity* 9, No. 6, 1703–1751 (1996)
479. Niederman, L.: Exponential stability for small perturbations of steep integrable Hamiltonian systems. *Ergodic Theory Dyn. Syst.* 24, No. 2, 593–608 (2004)
480. Niederman, L.: Exponential stability and subanalytic geometry. Preprint 2003–62, Université de Paris-Sud, Orsay, France
481. Nitecki, Z.: *Differentiable Dynamics. An Introduction to the Orbit Structure of Diffeomorphisms*. The M. I. T. Press, Cambridge, Mass.–London (1971), 282 pp.
482. Northrop, Th. G.: *The Adiabatic Motion of Charged Particles*. Interscience Publishers, a division of John Wiley and Sons, New York–London–Sydney (1963), 109 pp.
483. Novikov, E. A., Sedov, Yu. B.: Stochastic properties of a four-vortex system. *Zh. Ehksper. Teor. Fiz.* 75, No. 3, 868–876 (1978). Engl. transl.: *Sov. Phys., JETP* 48, No. 3, 440–444 (1978)
484. Novikov, S. P.: Variational methods and periodic solutions of equations of Kirchhoff type. II. *Funkts. Anal. Prilozh.* 15, No. 4, 37–52 (1981). Engl. transl.: *Funct. Anal. Appl.* 15, No. 4, 263–274 (1982)

485. Novikov, S.P.: The Hamiltonian formalism and a multi-valued analogue of Morse theory. *Usp. Mat. Nauk* 37, No. 5(227), 3–49 (1982). Engl. transl.: *Russ. Math. Surv.* 37, No. 5, 1–56 (1982)
486. Novikov, S.P., Tajmanov, I.A.: Periodic extremals of multi-valued or not-everywhere-positive functionals. *Dokl. Akad. Nauk SSSR* 274, 26–28 (1984). Engl. transl.: *Sov. Math., Dokl.* 29, 18–20 (1984)
487. Novikov, S.P., Shmel'tser, I.: Periodic solutions of Kirchhoff equations for the free motion of a rigid body in a fluid and the extended Lyusternik–Shnirel'man–Morse theory. I. *Funkts. Anal. Prilozh.* 15, No. 3, 54–66 (1981). Engl. transl.: *Funct. Anal. Appl.* 15, No. 3, 197–207 (1982)
488. Osipov, Yu. S.: Geometric interpretation of Kepler problem. *Usp. Mat. Nauk* 27, No. 2, 161 (1972) (Russian)
489. Pak, C.H., Rosenberg, R.M.: On the existence of normal mode vibrations in nonlinear systems. *Q. Appl. Math.* 26, 403–416 (1968)
490. Palais, R.S., Smale, S.: A generalized Morse theory. *Bull. Am. Math. Soc.* 70, 165–172 (1964)
491. Palamodov, V.P.: Stability of equilibrium in a potential field. *Funkts. Anal. Prilozh.* 11, No. 4, 42–55 (1977). Engl. transl.: *Funct. Anal. Appl.* 11, 277–289 (1978)
492. Palamodov, V.P.: Stability of motion and algebraic geometry. In: Kozlov, V.V. (ed.) *Dynamical Systems in Classical Mechanics*. Transl., Ser. 2, Am. Math. Soc. 168(25) (1995), 5–20
493. Pancharatnam, S.: Generalized theory of interference, and its applications. I. Coherent pencils. *Proc. Indian Acad. Sci. Sect. A* 44, 247–262 (1956)
494. Panov, D.A.: Multicomponent pseudo-periodic mappings. *Funkts. Anal. Prilozh.* 30, No. 1, 30–38 (1996). Engl. transl.: *Funct. Anal. Appl.* 30, No. 1, 23–29 (1996)
495. Paternain, G.: Entropy and completely integrable Hamiltonian systems. *Proc. Am. Math. Soc.* 113, No. 3, 871–873 (1991)
496. Paternain, G.P.: On the topology of manifolds with completely integrable geodesic flows. *Ergodic Theory Dyn. Syst.* 12, No. 1, 109–122 (1992)
497. Percival, I.C.: Variational principles for the invariant toroids of classical dynamics. *J. Physics A* 7, 794–802 (1974)
498. Percival, I.C.: A variational principle for invariant tori of fixed frequency. *J. Physics A* 12, L57–L60 (1979)
499. Percival, I.C.: Variational principles for invariant tori and cantori. In: *Nonlinear Dynamics and the Beam–Beam Interaction*. Sympos., Brookhaven Nat. Lab., New York, 1979. *AIP Conf. Proc.* 57, Amer. Inst. Physics, New York (1980), 302–310
500. Pidkujko, S.I., Stepin, A.M.: Polynomial integrals of Hamiltonian systems. *Dokl. Akad. Nauk SSSR* 239, 50–53 (1978). Engl. transl.: *Sov. Math., Dokl.* 19, 282–286 (1978)
501. Poincaré, H.: Remarques sur une expérience de M. Birkeland. *C. R. Acad. Sci.* 123, 530–533 (1896)
502. Pokrovskij, V.L., Khalatnikov, I.M.: To the question of over-barrier reflection of particles of high energies. *Zh. Ehksper. Teor. Fiz.* 40, No. 6, 1713–1719 (1961). Engl. transl.: *Sov. Phys., JETP* 13, 1207–1210 (1961)
503. Pokrovskij, V.L., Savvinykh, S.K., Ulinich, F.R.: Over-barrier reflection in quasi-classical approximation, I; II. *Zh. Ehksper. Teor. Fiz.* 34, No. 5, 1272–

- 1277; No. 6, 1629–1631 (1958). Engl. transl.: Sov. Phys., JETP 7, No. 5, 879–884; No. 6, 1119–1121 (1958)
504. Popov, G.: Invariant tori, effective stability, and quasimodes with exponentially small error terms. I: Birkhoff normal forms. *Ann. Henri Poincaré* 1, No. 2, 223–248 (2000)
505. Popov, G.: KAM Tori and Quantum Birkhoff Normal Forms. *Sémin. Équ. Dériv. Partielles, 1999–2000. Exp. No. XX. École Polytech., Cent. Math., Palaiseau* (2000), 15 pp.
506. Popov, G.: KAM theorem and quasimodes for Gevrey Hamiltonians. *Mat. Contemp.* 26, 87–107 (2004)
507. Popov, G.: KAM theorem for Gevrey Hamiltonians. *Ergodic Theory Dyn. Syst.* 24, No. 5, 1753–1786 (2004)
508. Pöschel, J.: Über Invariante Tori in Differenzierbaren Hamiltonschen Systemen. Dissertation, Rheinische Friedrich–Wilhelms–Universität, Bonn, 1979. Beiträge zur Differentialgeometrie 3. Bonner Mathematische Schriften 120. Universität Bonn, Mathematisches Institut, Bonn (1980), 103 pp.
509. Pöschel, J.: Integrability of Hamiltonian systems on Cantor sets. *Commun. Pure Appl. Math.* 35, 653–696 (1982)
510. Pöschel, J.: On elliptic lower dimensional tori in Hamiltonian systems. *Math. Z.* 202, No. 4, 559–608 (1989)
511. Pöschel, J.: Nekhoroshev estimates for quasi-convex Hamiltonian systems. *Math. Z.* 213, No. 2, 187–216 (1993)
512. Pöschel, J.: A lecture on the classical KAM theorem. In: Katok, A. (ed.) et al., *Smooth Ergodic Theory and its Applications. Proc. AMS Summer Res. Inst. (Seattle, WA, 1999). Proc. Symp. Pure Math.* 69. American Mathematical Society, Providence, R. I. (2001), 707–732
513. Pronchatov, V. E.: On an error estimate for the averaging method in a two-frequency problem. *Mat. Sb., Nov. Ser.* 134, No. 1, 28–41 (1987). Engl. transl.: *Math. USSR, Sb.* 62, No. 1, 29–40 (1989)
514. Pronin, A. V., Treshchev, D. V.: On the inclusion of analytic maps into analytic flows. *Regul. Khaoticheskaya Din.* 2, No. 2, 14–24 (1997)
515. Pronin, A. V., Treshchev, D. V.: Continuous averaging in multi-frequency slow-fast systems. *Regul. Chaotic Dyn.* 5, No. 2, 157–170 (2000)
516. Pyartli, A. S.: Diophantine approximations on submanifolds of Euclidean space. *Funkts. Anal. Prilozh.* 3, No. 4, 59–62 (1969). Engl. transl.: *Funct. Anal. Appl.* 3, 303–306 (1970)
517. Ramis, J.-P., Schäfke, R.: Gevrey separation of fast and slow variables. *Nonlinearity* 9, No. 2, 353–384 (1996)
518. Roels, J.: An extension to resonant cases of Liapunov’s theorem concerning the periodic solutions near a Hamiltonian equilibrium. *J. Differ. Equations* 9, 300–324 (1971)
519. Roels, J.: Families of periodic solutions near a Hamiltonian equilibrium when the ratio of two eigenvalues is 3. *J. Differ. Equations* 10, 431–447 (1971)
520. Rosenberg, R. M.: Normal modes of nonlinear dualmode systems. *J. Appl. Mech.* 27 263–268 (1960); On normal vibrations of a general class of nonlinear dual-mode systems. *J. Appl. Mech.* 28 275–283 (1961).
521. Rubin, H., Ungar, P.: Motion under a strong constraining force. *Commun. Pure Appl. Math.* 10, 65–87 (1957)

522. Rudnev, M., Wiggins, S.: KAM theory near multiplicity one resonant surfaces in perturbations of a-priori stable Hamiltonian systems. *J. Nonlinear Sci.* 7, No. 2, 177–209 (1997)
523. Rüssmann, H.: Über das Verhalten analytischer Hamiltonscher Differentialgleichungen in der Nähe einer Gleichgewichtslösung. *Math. Ann.* 154, 285–300 (1964)
524. Rüssmann, H.: Kleine Nenner. I. Über invariante Kurven differenzierbarer Abbildungen eines Kreisringes. *Nachr. Akad. Wiss. Göttingen Math.-Phys. Kl. II* 1970, 67–105 (1970)
525. Rüssmann, H.: Kleine Nenner. II: Bemerkungen zur Newtonschen Methode. *Nachr. Akad. Wiss. Göttingen, II. Math.-Phys. Kl.* 1972, 1–10 (1972)
526. Rüssmann, H.: On optimal estimates for the solutions of linear partial differential equations of first order with constant coefficients on the torus. In: *Dyn. Syst., Theor. Appl., Battelle Seattle 1974 Renc., Lect. Notes Phys.* 38 (1975), 598–624
527. Rüssmann, H.: Non-degeneracy in the perturbation theory of integrable dynamical systems. In: Dodson, M. M. (ed.) et al. *Number Theory and Dynamical Systems*, Lond. Math. Soc. Lect. Note Ser. 134, Cambridge Univ. Press, Cambridge (1989), 5–18
528. Rüssmann, H.: Invariant Tori in the Perturbation Theory of Weakly Non-Degenerate Integrable Hamiltonian Systems. Preprint-Reihe des Fachbereichs Mathematik der Johannes Gutenberg. Universität Mainz 1998, No. 14 (1998), 89 pp.; Rüssmann, H.: Invariant tori in non-degenerate nearly integrable Hamiltonian systems. *Regul. Chaotic Dyn.* 6, No. 2, 119–204 (2001)
529. Rüssmann, H.: Addendum to “Invariant tori in non-degenerate nearly integrable Hamiltonian systems”, *RCD* 6(2) 2001. *Regul. Chaotic Dyn.* 10, No. 1, 21–31 (2005)
530. Rytov, S. M.: Sur la transition de l’optique ondulatoire à l’optique géométrique. *Dokl. Akad. Nauk SSSR* 18, 263–266 (1938)
531. Saari, D. G., Xia, Zh.: Off to infinity in finite time. *Notices Am. Math. Soc.* 42, No. 5, 538–546 (1995)
532. Sadehtov, S. T.: A proof of the Mishchenko–Fomenko conjecture (1981). *Dokl. Akad. Nauk* 397, No. 6, 751–754 (2004). Engl. transl.: *Dokl. Math.* 70, No. 1, 634–638 (2004)
533. Salamon, D.: The Kolmogorov–Arnold–Moser Theorem. ETH–Zürich, 1986 (preprint), 44 pp.; Salamon, D. A. The Kolmogorov–Arnold–Moser Theorem. *Math. Phys. Electron. J.* 10, Paper No. 3 (2004), 37 pp.
534. Sanders, J.: Are higher order resonances really interesting? *Celest. Mech.* 16, 421–440 (1977)
535. Sauzin, D.: Nekhoroshev estimates and instability for Gevrey class Hamiltonians. In: *Dynamical Systems. Part I. Hamiltonian Systems and Celestial Mechanics. Selected papers from the Research Trimester held in Pisa, Italy, February 4 – April 26, 2002. Pubblicazioni del Centro di Ricerca Matematica Ennio de Giorgi, Proceedings. Scuola Normale Superiore, Pisa* (2003), 199–217
536. Schrödinger, E.: A method of determining quantum-mechanical eigenvalues and eigenfunctions. *Proc. R. Ir. Acad., Sect. A* 46, 9–16 (1940)
537. Seifert, H.: Periodische Bewegungen mechanischer Systeme. *Math. Z.* 51, 197–216 (1948)
538. Seifert, H.: Closed integral curves in 3-space and isotopic two-dimensional deformations. *Proc. Am. Math. Soc.* 1, 287–302 (1950)

539. Séré, É.: Looking for the Bernoulli shift. *Ann. Inst. Henri Poincaré, Anal. Non Linéaire* 10, No. 5, 561–590 (1993)
540. Sevryuk, M. B.: KAM-stable Hamiltonians. *J. Dyn. Control Syst.* 1, No. 3, 351–366 (1995)
541. Sevryuk, M. B.: The iteration-approximation decoupling in the reversible KAM theory. *Chaos* 5, No. 3, 552–565 (1995)
542. Sevryuk, M. B.: Invariant tori of Hamiltonian systems that are nondegenerate in Rüssmann’s sense. *Dokl. Akad. Nauk* 346, No. 5, 590–593 (1996). Engl. transl.: *Dokl. Math.* 53, No. 1, 69–72 (1996)
543. Sevryuk, M. B.: Invariant tori of intermediate dimensions in Hamiltonian systems. *Regul. Khaoticheskaya Din.* 2, No. 3–4, 30–40 (1997). Engl. transl.: *Regul. Chaotic Dyn.* 3, No. 1, 39–48 (1998)
544. Sevryuk, M. B.: Excitation of elliptic normal modes of invariant tori in Hamiltonian systems. In: Khovanskij, A. G. (ed.) et al. *Topics in Singularity Theory. V. I. Arnold’s 60th Anniversary Collection. Transl., Ser. 2, Am. Math. Soc.* 180(34). American Mathematical Society, Providence, R. I. (1997), 209–218
545. Sevryuk, M. B.: The finite-dimensional reversible KAM theory. *Phys. D* 112, No. 1–2, 132–147 (1998)
546. Sevryuk, M. B.: The classical KAM theory at the dawn of the twenty-first century. *Mosc. Math. J.* 3, No. 3, 1113–1144 (2003)
547. Sevryuk, M. B.: Partial preservation of frequencies in KAM theory. *Nonlinearity* 19, No. 5, 1099–1140 (2006)
548. Shkredov, I. D.: Recurrence in mean. *Mat. Zametki* 72, No. 4, 625–632 (2002). Engl. transl.: *Math. Notes* 72, No. 4, 576–582 (2002)
549. Sidorenko, V. V.: Capture and escape from resonance in the dynamics of the rigid body in viscous medium. *J. Nonlinear Sci.* 4, No. 1, 35–57 (1994)
550. Simó, C.: Averaging under fast quasiperiodic forcing. In: *Hamiltonian Mechanics (Toruń, 1993), NATO Adv. Sci. Inst. Ser. B Phys.* 331. Plenum, New York (1994), 13–34
551. Simó, C.: New families of solutions in N -body problems. In: Casacuberta, C. (ed.) et al. *3rd European Congress of Mathematics (ECM), Barcelona, Spain, July 10–14, 2000, Vol. I. Prog. Math.* 201. Birkhäuser, Basel (2001), 101–115
552. Simó, C.: Periodic orbits of the planar N -body problem with equal masses and all bodies on the same path. Preprint (2001)
553. Simó, C.: Dynamical properties of the figure eight solution of the three-body problem. In: Chenciner, A. (ed.) et al. *Proc. Int. Conf. Celestial Mechanics, Northwestern Univ. (Evanston, IL, 1999). Contemp. Math.* 292. American Mathematical Society, Providence, R. I. (2002), 209–228
554. Sinaj, Ya. G., Khanin, K. M.: Mixing for some classes of special flows over rotations of the circle. *Funkts. Anal. Prilozh.* 26, No. 3, 1–21 (1992). Engl. transl.: *Funct. Anal. Appl.* 26, No. 3, 155–169 (1992)
555. Sinaj, Ya. G.: *Introduction to Ergodic Theory. FAZIS, Moscow* (1996), 132 pp. Engl. transl. of 1st ed.: *Mathematical Notes* 18. Princeton Univ. Press, Princeton, N. J. (1976), 144 pp.
556. Sinclair, A. T.: On the origin of commensurabilities among the satellites of Saturn. I, II. *Monthly Notices Roy. Astron. Soc.* 160, No. 2, 169–187 (1972); 166, No. 1, 165–179 (1974)
557. Slawianowski, J. J.: Bertrand systems on $SO(3, \mathbb{R})$ and $SU(2)$. *Bull. Acad. Pol. Sci., Sér. Sci. Phys. Astron.* 28, 83–94 (1980)

558. Slutskin, A. A.: On the motion of a one-dimensional non-linear oscillator in adiabatic conditions. *Zh. Ehksper. Teor. Fiz.* 45, No. 4, 978–988 (1963). Engl. transl.: *Sov. Phys., JETP* 18, 676–682 (1963)
559. Smale, S.: Mathematical problems for the next century. *Math. Intelligencer* 20, No. 2, 7–15 (1998). Reprinted in: Arnold, V. I. (ed.) et. al. *Mathematics: Frontiers and Perspectives*. American Mathematical Society, Providence, R. I. (2000), 271–294
560. Sokolov, V. V.: A new integrable case for the Kirchhoff equation. *Teor. Mat. Fiz.* 129, No. 1, 31–37 (2001). Engl. transl.: *Theor. Math. Phys.* 129, No. 1, 1335–1340 (2001)
561. Sokol'skij, A. G.: On the stability of an autonomous Hamiltonian system with two degrees of freedom in the case of equal frequencies. *Prikl. Mat. Mekh.* 38, No. 5, 791–799 (1974). Engl. transl.: *J. Appl. Math. Mech.* 38, No. 5, 741–749 (1974)
562. Sokol'skij, A. G.: On stability of an autonomous Hamiltonian system with two degrees of freedom under first-order resonance. *Prikl. Mat. Mekh.* 41, No. 1, 24–33 (1977). Engl. transl.: *J. Appl. Math. Mech.* 41, No. 1, 20–28 (1977)
563. Sokol'skij, A. G.: Proof of the stability of Lagrangian solutions for a critical mass ratio. *Pis'ma Astron. Zh.* 4, No. 3, 148–152 (1978). Engl. transl.: *Sov. Astron. Lett.* 4, 79–81 (1978)
564. Solov'yev, V. V., Shklyar, D. R.: Heating of particles by a wave of small amplitude in non-homogeneous magneto-active plasma. *Zh. Ehksper. Teor. Fiz.* 90, No. 2, 471–480 (1986). Engl. transl.: *Sov. Phys., JETP* 63, 272–277 (1986)
565. Souriau, J.: *Structure des Systèmes Dynamiques*. Maitrises de Mathématique. Dunod, Paris (1970), 414 pp.
566. Sparrow, C.: *The Lorenz Equations: Bifurcations, Chaos, and Strange Attractors*. Applied Mathematical Sciences 41. Springer-Verlag, New York–Heidelberg–Berlin (1982), 269 pp.
567. Sprindzhuk, V. G.: *Mahler's Problem in Metric Number Theory*. Nauka i Tekhnika, Minsk (1967), 182 pp. Engl. transl.: *Translations of Mathematical Monographs* 25. American Mathematical Society, Providence, R. I. (1969), 192 pp.
568. Stephenson, A.: On a new type of dynamical stability. *Mem. Manchester Soc.* 52, No. 8, 1–10 (1908)
569. Steklov, V. A.: A new particular solution of the differential equations of the motion of a heavy rigid body having a fixed point. *Trudy Otdel. Fiz. Nauk Obshchestva Lyubit. Estestvozn.* 10, No. 1, 1–3 (1899) (Russian)
570. Svanidze, N. V.: Small perturbations of an integrable dynamical system with an integral invariant. *Tr. Mat. Inst. Steklova* 147, 124–146 (1980). Engl. transl.: *Proc. Steklov Inst. Math.* 147, 127–151 (1981)
571. Tajmanov, I. A.: Topological obstructions to the integrability of geodesic flows on nonsimply connected manifolds. *Izv. Akad. Nauk SSSR Ser. Mat.* 51, No. 2, 429–435 (1987). Engl. transl.: *Math. USSR, Izv.* 30, No. 2, 403–409 (1988)
572. Tajmanov, I. A.: On topological properties of integrable geodesic flows. *Mat. Zametki* 44, No. 2, 283–284 (1988) (Russian)
573. Tajmanov, I. A.: Nonselfintersecting closed extremals of multivalued or not everywhere positive functionals. *Izv. Akad. Nauk SSSR, Ser. Mat.* 55, No. 2, 367–383 (1991). Engl. transl.: *Math. USSR, Izv.* 38, No. 2, 359–374 (1992)

574. Tajmanov, I. A.: Closed nonself-intersecting extremals of multivalued functionals. *Sib. Mat. Zh.* 33, No. 4, 155–162 (1992). Engl. transl.: *Sib. Math. J.* 33, No. 4, 686–692 (1992)
575. Tajmanov, I. A.: Closed extremals on two-dimensional manifolds. *Usp. Mat. Nauk* 47, No. 2(284), 143–185 (1992). Engl. transl.: *Russ. Math. Surv.* 47, No. 2, 163–211 (1992)
576. Tajmanov, I. A.: On the existence of three closed nonself-intersecting geodesics on manifolds homeomorphic to the 2-sphere. *Izv. Ross. Akad. Nauk, Ser. Mat.* 56, No. 3, 605–635 (1992). Engl. transl.: *Russ. Acad. Sci., Izv., Math.* 40, No. 3, 565–590 (1993)
577. Takens, F.: A C^1 counterexample to Moser's twist theorem. *Nederl. Akad. Wet., Proc., Ser. A* 74, 379–386 (1971)
578. Takens, F.: Motion under the influence of a strong constraining force. In: *Global Theory of Dynamical Systems, Proc. Int. Conf.* (Evanston, Ill., 1979). *Lect. Notes Math.* 819. Springer-Verlag, Berlin (1980), 425–445
579. Tatarinov, Ya. V.: Portraits of the classical integrals of the problem of rotation of a rigid body about a fixed point. *Vestn. Mosk. Univ., Ser. I Mat. Mekh.* 29, No. 6, 99–105 (1974) (Russian)
580. Tatarinov, Ya. V.: Geometrical formalism of classical dynamics: natural integrals and reduction. *Vestn. Mosk. Univ., Ser. I Mat. Mekh.* 1978, No. 3, 109–118 (1978). Engl. transl.: *Mosc. Univ. Mech. Bull.* 33, No. 3–4, 26–33 (1978)
581. Tatarinov, Ya. V.: Approximate form of the accessible domain in perturbed Liouville systems. *Teor. Primen. Meh. (Beograd)* 8, 133–138 (1982) (Russian)
582. Ten, V. V.: Analytic invariants of dynamical systems with positive entropy. *Vestn. Mosk. Univ., Ser. I Mat. Mekh.* 1997, No. 3, 40–43 (1997). Engl. transl.: *Mosc. Univ. Mech. Bull.* 52, No. 3, 1–4 (1997)
583. Timofeev, A. V.: On the constancy of an adiabatic invariant when the nature of the motion changes. *Zh. Ehksper. Teor. Fiz.* 75, No. 4, 1303–1308 (1978). Engl. transl.: *Sov. Phys., JETP* 48, 656–659 (1978)
584. Treshchev, D. V.: The mechanism of destruction of resonance tori of Hamiltonian systems. *Mat. Sb.* 180, No. 10, 1325–1346 (1989). Engl. transl.: *Math. USSR, Sb.* 68, No. 1, 181–203 (1990)
585. Treshchev, D. V.: Separatrix Splitting for a Pendulum with Rapidly Oscillating Suspension Point. Preprint No. 273. Centre de Recerca Matemàtica, Institut d'Estudis Catalans. Barcelona (1994), 40 pp.
586. Treshchev, D. V.: An estimate of irremovable nonconstant terms in the reducibility problem. In: Kozlov, V. V. (ed.) *Dynamical Systems in Classical Mechanics. Transl., Ser. 2*, Am. Math. Soc. 168(25) (1995), 91–128
587. Treshchev, D. V.: An averaging method for Hamiltonian systems, exponentially close to integrable ones. *Chaos* 6, No. 1, 6–14 (1996)
588. Treshchev, D. V.: Splitting of separatrices for a pendulum with rapidly oscillating suspension point. *Russ. J. Math. Phys.* 5, No. 1, 63–98 (1997)
589. Treshchev, D. V.: The method of continuous averaging in the problem of separation of fast and slow motions. *Regul. Khaoticheskaya Din.* 2, No. 3–4, 9–20 (1997). Engl. transl.: *Regul. Chaotic Dyn.* 2, No. 3, 9–20 (1997)
590. Treshchev D. V.: Width of stochastic layers in near-integrable two-dimensional symplectic maps. *Phys. D* 116, No. 1–2, 21–43 (1998)
591. Treshchev, D. V. Evolution of slow variables in a priori unstable Hamiltonian systems. *Nonlinearity* 17, No. 5, 1803–1841 (2004)

592. Trifonov, S. I.: Analytic diffeomorphisms as monodromy transforms of analytic differential equations. *Vestn. Mosk. Univ., Ser. I Mat. Mekh.* 1985, No. 5, 70–72 (1986). Engl. transl.: *Mosc. Univ. Math. Bull.* 41, No. 5, 63–65 (1986)
593. Vajnshtejn, A. D., Shapiro, B. Z.: Higher-dimensional analogs of the theorems of Newton and Ivory. *Funkts. Anal. Prilozh.* 19, No. 1, 20–24 (1985). Engl. transl.: *Funct. Anal. Appl.* 19, 17–20 (1985)
594. Vainshtein, D. L., Vasiliev, A. A., Nejshtadt, A. I.: Changes in the adiabatic invariant and streamline chaos in confined incompressible Stokes flow. *Chaos* 6, No. 1, 67–77 (1996)
595. Vashkov'yak, M. A.: Evolution of orbits in the restricted circular doubly averaged three-body problem. 1. Qualitative study. *Kosmich. Issled.* 19, No. 1, 5–18 (1981) (Russian)
596. Vasiliev, A. A., Itin, A. P., Nejshtadt, A. I.: On dynamics of four globally phase-coupled oscillations with close frequencies. *Regul. Khaoticheskaya Din.* 2, No. 3–4, 21–29 (1997). Engl. transl.: *Regul. Chaotic Dyn.* 3, No. 1, 9–18 (1998)
597. Vecheslavov, V. V., Chirikov, B. V.: What is the Rate of Arnol'd's Diffusion? Preprint 89–72 Inst. Nuclear Physics Siber. Branch Akad. Nauk SSSR, Novosibirsk (1989), 30 pp. (Russian)
598. Veselov, A. P., Veselova, L. E.: Currents on Lie groups with nonholonomic connection and integrable non-Hamiltonian systems. *Funkts. Anal. Prilozh.* 20, No. 4, 65–66 (1986). Engl. transl.: *Funct. Anal. Appl.* 20, 308–309 (1986)
599. Vladimirskij, V. V. On rotation of the plane of polarization in a bent light ray. *Dokl. Akad. Nauk SSSR* 31, No. 3, 222–225 (1941) (Russian)
600. Volosov, V. M., Morgunov, B. I.: *Averaging Method in the Theory of Nonlinear Oscillations.* Moscow Univ., Moscow (1971), 507 pp. (Russian)
601. Vorovich I. I.: The notion “mass” and the principle of equivalence. *Izv. VUZ., Severo-Kavkaz. Region. Estestv. Nauki* 2001, 40–46 (2001) (Russian)
602. Wagener, F.: A note on Gevrey regular KAM theory and the inverse approximation lemma. *Dyn. Syst.* 18, No. 2, 159–163 (2003)
603. Whittaker, E. T., Watson, G. N.: *A Course in Modern Analysis.* Cambridge University Press, Cambridge (1990), 132 pp.
604. Wisdom, J.: A perturbative treatment of motion near 3/1 commensurability. *Icarus* 63, No. 2, 272–289 (1985)
605. Wolansky, G.: Limit theorem for a dynamical system in the presence of resonances and homoclinic orbits. *J. Differ. Equations* 83, No. 2, 300–335 (1990)
606. Xia, Zh.: Arnold diffusion: a variational construction. *Doc. Math., J. DMV, Extra Vol. ICM Berlin 1998, vol. II*, 867–877 (1998)
607. Xia, Zh.: The existence of noncollision singularities in Newtonian systems. *Ann. Math.* (2) 135, No. 3, 411–468 (1992)
608. Xia, Zh.: Arnold diffusion and oscillatory solutions in the planar three-body problem. *J. Differ. Equations* 110, No. 2, 289–321 (1994)
609. Xu, J.: Persistence of elliptic lower dimensional invariant tori for small perturbation of degenerate integrable Hamiltonian systems. *J. Math. Anal. Appl.* 208, No. 2, 372–387 (1997)
610. Xu, J.: Persistence of lower dimensional invariant tori for nearly integrable Hamiltonian systems. *Nonlinear Anal., Theory Methods Appl.* 52, No. 2(A), 383–403 (2003)
611. Xu, J., You, J.: Persistence of lower-dimensional tori under the first Melnikov's non-resonance condition. *J. Math. Pures Appl.*, IX. Sér. 80, 1045–1067 (2001)

612. Xu, J., You, J.: A symplectic map and its application to the persistence of lower dimensional invariant tori. *Sci. China Ser. A* 45, No. 5, 598–603 (2002)
613. Yudovich, V. I.: Asymptotics of Limit Cycles of the Lorenz System for Large Rayleigh Numbers. *Dep. 18.05.78, No. 2611–78. VINITI, Moscow* (1978), 49 pp. (Russian)
614. Yakubovich, V. A., Starzhinskij, V. M.: *Linear Differential Equations with Periodic Coefficients. I; II.* Nauka, Moscow (1972), 718 pp. Engl. transl.: I. Halsted Press (John Wiley & Sons) New York–Toronto, Ont.; II. Israel Program for Scientific Translations, Jerusalem–London (1975), 386 pp., 387–839.
615. Yoccoz, J.-C.: Travaux de Herman sur les tores invariants. *Séminaire Bourbaki, Vol. 1991/92. Exposés 745–759. Société Mathématique de France, Paris. Astérisque 206, 311–344 (Exp. No. 754)* (1992)
616. Yoshida, H.: Necessary condition for the existence of algebraic first integrals. I. Kowalevski's exponents. II. Condition for algebraic integrability. *Celestial Mech.* 31, 363–379; 381–399 (1983)
617. You, J.: A KAM theorem for hyperbolic-type degenerate lower dimensional tori in Hamiltonian systems. *Commun. Math. Phys.* 192, No. 1, 145–168 (1998)
618. You, J.: Perturbations of lower dimensional tori for Hamiltonian systems. *J. Differ. Equations* 152, No. 1, 1–29 (1999)
619. Young, L. C.: *Lectures on the Calculus of Variations and Optimal Control Theory.* W. B. Saunders Company, Philadelphia–London–Toronto (1969), 331 pp.
620. Zaslavskij, G. M., Chirikov, B. V.: Stochastic instability of non-linear oscillations. *Usp. Fiz. Nauk* 105, No. 1, 3–39 (1971). Engl. transl.: *Sov. Phys., Usp.* 14, No. 5, 549–568 (1972)
621. Zaslavskij, G. M., Sagdeev, R. Z.: *Introduction to Nonlinear Physics. From the Pendulum to Turbulence and Chaos.* Nauka, Moscow (1988), 368 pp. Engl. transl.: Sagdeev, R. Z., Usikov, D. A., Zaslavsky, G. M. *Nonlinear Physics: From the Pendulum to Turbulence and Chaos.* Harwood, New York (1988), 676 pp.
622. Zehnder, E.: Generalized implicit function theorems with applications to some small divisor problems. I; II. *Commun. Pure Appl. Math.* 28, 91–140 (1975); 29, 49–111 (1976)
623. Ziglin, S. L.: Secular evolution of the orbit of a planet in a binary-star system. *Pis'ma Astron. Zh.* 1, No. 9, 45–47 (1975). Engl. transl.: *Sov. Astron. Lett.* 1, No. 5, 194–195 (1975)
624. Ziglin, S. L.: Nonintegrability of a problem on the motion of four point vortices. *Dokl. Akad. Nauk SSSR* 250, 1296–1300 (1980). Engl. transl.: *Sov. Math., Dokl.* 21, 296–299 (1980)
625. Ziglin, S. L.: Splitting of separatrices, branching of solutions, and non-existence of an integral in the dynamics of a rigid body. *Tr. Mosk. Mat. O.-va* 41, 287–302 (1980). Engl. transl.: *Trans. Mosc. Math. Soc.* 1982, No. 1, 283–298 (1982).
626. Ziglin, S. L. Self-intersection of the complex separatrices and the nonexistence of the integrals in the Hamiltonian systems with one-and-half degrees of freedom. *Prikl. Mat. Mekh.* 45, No. 3, 564–566 (1981). Engl. transl.: *J. Appl. Math. Mech.* 45, No. 3, 411–413 (1982)
627. Ziglin, S. L. Branching of solutions and nonexistence of first integrals in Hamiltonian mechanics. I; II. *Funkts. Anal. Prilozh.* 16, No. 3, 30–41 (1982); 17, No. 1, 8–23 (1983). Engl. transl.: *Funct. Anal. Appl.* 16, 181–189 (1983); 17, 6–17 (1983)

Index of Names

- Abrarov D. L. 105
Aharonov Y. 332
Alekseev V. M. 85, 374, 378, 381
Alfriend K. T. 409
Ampère A.-M. 438
Andoyer H. 124
Andronov A. A. 314
Anosov D. V. 243, 393
Antonov V. A. 308
Appel'rot G. G. 371
Appell P. 4, 203–205
Arnold V. I. 85, 160, 161, 270, 462
Arzelá C. 163, 164
Aubry S. 170, 288, 308, 310
- Baire R.-L. 382
Bakhtin V. I. 277
Bangert V. 146
Bekker L. 84, 85
Beltrami E. 95, 313, 462
Bernoulli D. 15, 16
Bernoulli J. 16
Berry M. 327, 328
Bertrand J. L. F. 64, 95, 96
Bessel W. 68
Bessi U. 288
Betti E. 147, 396
Biot J.-B. 101
Birkeland K. 7
Birkhoff G. D. 40, 85, 90, 146, 150, 169,
171, 176–178, 309, 357, 380–382,
394, 401, 406, 407, 418
Block H. 78
- Bogolyubov N. N. 167, 210, 211, 218,
222, 228, 229, 310, 439
Bohlin K. 66, 211, 268
Bohm D. 332
Bolotin S. V. VI, 105, 116, 149, 150,
152, 366, 394
Boltzmann L. 314
Bonnet P. O. 393
Bour E. 172
Bryuno A. D. 384
Bunyakovskij V. Ya. 163
Burgers J. 324
Burrau C. 75
- Carathéodory C. 42, 55, 118
Cartan E. 39, 41, 114, 117, 119, 120,
184, 185, 434–436, 452, 464, 465
Cauchy A. L. 69, 163, 192, 386, 463
Chaplygin S. A. 108, 109, 115, 186,
190, 193, 200, 201, 391, 445
Charlier C. L. 197
Chazy I. F. 78, 83, 84, 375, 381, 454
Chebyshev P. L. 146
Chelomei V. N. 222
Cheng Ch.-Q. 278
Chetaev N. G. 416, 423, 426–429
Childress S. 462
Chirikov B. V. 283
Clairaut A. C. 34, 62
Clebsch R. F. 189, 190, 203, 373, 465
Coriolis G. 13
Courant R. 54, 403
- D'Alembert J. R. 18, 27, 41, 44

- d'Arcy P. 15
 Darboux G. 30
 Delaunay C. 182, 211, 268, 269
 Deprit A. 269
 De la Llave R. 293
 Dinaburg E. I. 396
 Dirac P. A. M. 31, 48–51, 59, 60, 111, 185, 324
 Dirichlet P. 422–424, 426, 427
 Duffing G. 240
 Duistermaat J. J. 409

 Earnshaw S. 426, 428
 Ehrenfest P. 314
 Euler L. 15, 24–26, 34, 38, 40, 70, 79, 80, 85, 87, 98, 105, 122, 137, 186, 196, 197, 199, 200, 226, 254, 255, 258, 371, 391, 394, 424

 Fathi A. 310
 Fatou P. 218
 Fet A. I. 146, 150
 Fisher E. 403
 Flaschka H. 198
 Floquet G. 223, 298, 441
 Fomenko A. T. 184
 Foucault J. 142
 Foure R. 66
 Franks J. 146
 Frobenius G. 29
 Fuchs I. L. 459

 Gajdukov E. V. 393
 Galgani L. 372
 Galilei Galileo 3, 9, 11
 Gauss C. F. 27, 28, 41, 140, 204, 259, 393
 Gelfreich V. G. 284
 Gevrey M. 218
 Ginzburg V. L. 161
 Giorgilli A. 372
 Givental' A. B. 72
 Gordon W. B. 96
 Goryachev D. N. 186, 193, 391
 Grobman D. M. 369
 Gromoll D. 146
 Gromov M. L. 396
 Gustavson F. 178

 Hölder O. L. 27–29, 41, 42, 44

 Hénon M. 178, 198, 391
 Hadamard J. S. 145, 147
 Hagedorn P. 167
 Hall E. H. 332
 Hamilton W. R. 19, 22, 31, 41, 44, 135–137, 165, 179, 192, 462, 463
 Hannay J. 327, 329
 Hartman P. 369
 Hedlund G. 380
 Heiles C. 178, 391
 Helmholtz H. L. F. 41, 115, 432, 449, 464, 465
 Henrard J. 409
 Herman M. 261, 272, 278, 298, 303, 306
 Hertz H. R. 29, 44, 115
 Hess W. 371
 Hilbert D. 39, 308
 Hill G. W. 87, 89–93, 144
 Hooke R. 3
 Hopf H. 141
 Hori G. 269
 Huygens H. 4, 5, 7, 16

 Ishlinskij A. Yu. 327, 328
 Ivory J. 98, 101

 Jacobi C. 19, 73, 86–88, 104, 124, 135, 137, 138, 165, 186, 192, 194–197, 200, 360, 448, 463
 Jordan C. 175

 Kapitsa P. L. 222
 Kasuga T. 243
 Katok A. B. 394
 Katok S. B. 132
 Kelvin W. 426–429
 Kepler J. 4, 62, 64, 70, 96, 97, 394
 Kharlamova E. I. 206
 Kirchhoff G. R. 26, 157, 190
 Kirkwood D. 251, 349
 Klein F. 19
 Klingenberg W. 146
 Kneser A. 166
 Kolmogorov A. N. 200, 201, 270, 274, 275, 277, 296, 298–300, 302, 306, 354, 357, 454
 Kolokol'tsov V. N. 394
 Kontsevich M. L. 398
 Korteweg D. J. 203–205

- Kovalevskaya S. V. 186, 188, 190, 191,
 391, 458, 459
 Kozai Y. 260
 Kozlov V. V. 41, 371, 373
 Krylov N. M. 210, 211, 310, 439
 Kummer E. 462
 Kutta W. 226
 Kuz'mina R. P. 132
 Kuznetsov A. N. 425
- Lagrange J. L. 16, 18, 19, 27, 35, 38,
 41–44, 49, 68, 69, 73, 79–81, 85, 87,
 98, 104, 107, 124, 130, 137, 153,
 186, 196, 197, 207, 210, 260, 261,
 267, 312, 391, 401, 422–424, 426,
 427, 463
 Laloy M. 424
 Lamb H. 57, 461
 Laplace P. S. 2, 17, 95, 207, 210, 260,
 261, 267, 313
 Larmor J. 6
 Lazutkin V. F. 283
 Lebesgue H. L. 93
 Lee H.-C. 436
 Legendre A. M. 9, 34
 Leibnitz G. W. 4, 31
 Leontovich M. A. 314
 Leverrier M. 358
 Levi-Civita T. 331, 332
 Levy M. 104
 Lidov M. L. 260
 Lie S. 117, 172, 184, 185
 Lindstedt A. 211, 265–271, 289, 407
 Liouville J. 40, 93, 172, 199, 204, 438,
 444, 452, 465, 467
 Littlewood J. E. 94, 205
 Long Y. 152, 153
 Lorentz H. A. 6
 Lorenz E. N. 251
 Lyapunov A. M. 78, 88, 91, 177, 190,
 223, 296, 313, 355, 384, 388, 391,
 423, 424, 441, 459
 Lyusternik L. A. 146, 150, 151, 395
- Maclaurin C. 5
 Malus E. 462
 Manakov S. V. 198
 Mandel'shtam L. I. 210, 218, 314
 Markeev A. P. 409
- Marsden J. 119
 Mather J. 79, 136, 170, 288, 289, 293,
 308, 310
 Mathieu É. 340
 Maupertuis P. 66, 135, 137
 Maxwell J. C. 6
 McGehee R. 79
 Mel'nikov V. K. 170, 284, 292, 302, 364
 Merman G. A. 85
 Meyer W. 146
 Mishchenko A. S. 184
 Mitropol'skij Yu. A. 210
 Monge G. 438
 Morse M. 128, 136, 150, 158, 292, 380,
 427, 428
 Moser J. 71, 178, 198, 270, 272, 279,
 302
 Moulton F. R. 80
- Nöther E. 103, 104
 Nambu Y. 253
 Nash J. 272
 Navier C.-L. 449
 Nekhoroshev N. N. 181, 288, 289, 291
 Neumann C. 197
 Newcomb S. 211, 270
 Newton I. 2–4, 11, 15, 16, 62, 98, 101
 Novikov S. P. 158
- Ol'shanetskij M. A. 198
 Onishchenko D. A. 373
- Pöschel J. 272
 Painlevé P. 423
 Palais R. S. 168
 Palamodov V. P. 423, 424
 Pancharatnam S. 327, 328
 Papaleksi N. D. 210, 218
 Parasyuk I. O. 306
 Paternain G. P. 394, 396
 Percival I. C. 136, 307, 308, 310
 Perelomov A. M. 198
 Pfaff J. F. 192
 Pfeiffer K. 424
 Pidkuiko S. I. 198
 Piftankin G. N. 293
 Poincaré H. 6, 7, 23, 37–41, 48, 72, 75,
 78, 85, 92, 93, 105, 117, 119, 136,
 145, 159–161, 168–171, 211, 222,

- 228, 256, 260, 265–267, 270, 272,
 282, 284, 285, 292, 305, 309, 351,
 352, 355–360, 362–364, 370, 381,
 383, 385, 387, 397, 401, 427, 429,
 432–438, 445, 455, 456
 Poinsot L. 186, 254, 255, 258
 Poisson S. D. 26, 31, 35, 92, 93, 115,
 124, 186, 267
 Puiseux V. A. 70
 Pyartli A. S. 277

 Rüssmann H. 272, 277, 278, 301
 Radon J. 327, 331, 332
 Rayleigh J. W. 54, 403
 Rinow W. 141
 Roels J. 384, 409
 Routh E. J. 112, 113, 116, 117, 136
 Runge C. 226
 Rytov S. M. 327, 328

 Séré E. 169
 Sadehtov S. T. 184
 Sanders J. 409
 Savart F. 101
 Schmidt D. S. 409
 Schrödinger E. 66, 95, 313
 Schwarzschild H. 94, 205
 Seifert H. 150, 152, 161
 Sevryuk M. B. VI, 278
 Shil'nikov L. P. 381
 Shmidt O. Yu. 84, 85
 Shnirel'man L. G. 146, 151, 395
 Sidorenko V. V. 348
 Siegel C. L. 381–384
 Simó C. 82
 Sitnikov K. A. 83–85
 Smale S. 129, 130, 168, 381
 Sokolov V. V. 190, 191, 373
 Souriau J.-M. 119
 Sprindzhuk V. G. 277
 Stäckel P. 193
 Staude O. 127
 Steklov V. A. 190, 203, 373
 Stephenson A. 222
 Stepin A. M. 198

 Stewart H. J. 465
 Stokes G. 4, 39, 449, 451
 Strel'tsov A. A. 185
 Strelcyn J.-M. 372
 Sundman K. F. 75, 98
 Sun Y.-S. 278
 Suslov G. K. 44, 205
 Szebehely V. 75

 Tajmanov I. A. 396
 Tamm I. E. 311
 Tatarinov Ya. V. 132, 444
 Teichmüller O. 397
 Tennison J. 297
 Thomson J. J. 36, 41, 115, 449,
 463–465
 Tissèrand F. 203, 206
 Toda M. 198
 Treshchev D. V. VI, 284

 Van der Burgh A. H. P. 409
 Van der Pol B. 210, 220
 Van Kampen E. R. 126
 Vladimirkij V. V. 327, 328
 Von Zeipel H. 211, 268, 269, 289, 305,
 409

 Weierstrass K. 73, 75, 198, 352, 391
 Weinstein A. 119
 Weyl H. 175, 198, 440
 Whitehead A. N. 140
 Whittaker E. . 446, 449
 Williamson J. 405
 Wintner A. 68, 69, 126, 137, 423
 Wisdom J. 349

 Xia Zh. 288

 Yomdin Y. 396
 Yoshida H. 458

 Zaslavskij G. M. 399
 Zhukovskij N. E. 66
 Ziglin S. L. 367, 371–373, 389, 391
 Zorich A. V. 398
 Zubarev D. N. 211

Subject Index

- Abbreviated action 137
- Absolute integral invariant 433
- Acceleration 2, 13
- Action 22
 - at a distance 115
 - in the phase space 37
- Action and reaction 11
- Action form 34
- Action–angle variables 179
- Actual motion 27
- Adiabatic
 - approximation 316
 - connection 331
 - dynamic phase 327
 - geometric phase 327
 - invariant 314
- Aharonov–Bohm effect 332
- Almost adiabatic invariant 323
- Almost-eigenfunction 313
- Amended force function 114
- Amended potential 62, 82
- Angular
 - acceleration 13
 - momentum 15
 - velocity 13, 24
- Anisotropic friction 54
 - with total dissipation 54
- Anosov system 393
- Anosov’s theorem 243
- Apocentre 63
- Apsidal angle 63
- Area constant 62
- Area integral 62
- Arnold diffusion 289
- Asymptotic surface 357, 361
- Aubry–Mather set 308
- Aubry–Mather theory 288, 310
- Averaged system 208
- Averaging 209
- Averaging principle 208, 443
- Axial vectors 13

- Barycentre 16
- Beltrami–Laplace operator 313
- Bernoulli theorem 464
- Berry phase 327
- Berry’s formula 328
- Bessel function 68
- Bifurcation set 65, 128
- Birkhoff normal form 406, 408, 419
- Bogolyubov’s averaging principle of 229
- Bogolyubov’s standard form 228
- Bounded motion 83

- Canonical
 - coordinates 30
 - Hamilton’s equations 31
 - transformation 32, 33
- Cantor-circle 309
- Cantor set 308
- Capture in 3-body problem 84
- Capture into resonance 230
- Cartan’s equation 114
- Central configuration 79
- Central force 15
- Centre of mass 15

- Chaplygin system 445
 Chaplygin's problem 109
 Characteristic
 exponents 355
 frequency 403, 405
 oscillation 403, 405
 Choreographies 82
 Circular restricted 3-body problem 259
 Circulation 41
 Clairaut's equation 64
 Class of a differential form 465
 Clebsch potentials 465
 Closed mechanical system 11
 Closed sets of integrals 185
 Coding trajectories 380
 Coisotropic torus 306
 Complete integrability 29
 Complete integral 192
 Completely integrable
 constraints 29
 Hamiltonian system 174
 Compulsion according to Gauss 27
 Conceivable motion 27
 Condition for non-commutative integrability 185
 Conditional integral invariant 433
 Conditionally periodic function 176
 Conditionally periodic motion 175
 Configuration space 2
 Connection 331
 Conservative forces 15
 Constraint according to Gauss 27
 Constraint equation 18
 Constraints 48
 Continuity equation 465
 Continuous averaging 215
 Coriolis force 13
 Criterion for complete integrability 29
 Curvature form 114
 Cyclic coordinates 104
 Cyclic integral 104

 D'Alembert–Lagrange principle 18
 Darboux theorem 30
 Degree of instability 427, 429
 Degrees of freedom 19
 Delaunay elements 182
 Density of an integral invariant 438

 Dependent functions 352
 Destruction of adiabatic invariance 324, 344, 349
 Determinacy 2
 Deviation 141
 Diffusion 289
 Diophantine vectors 226
 Dissipation 426
 Dissipation function 54
 Dissipative system 429
 Dynamic adiabatic phase 327

 Earnshaw's theorem 426, 428
 Eccentric anomaly 67
 Effective force function 114
 Effective potential 62, 82
 Elliptic
 coordinates 194
 invariant torus 302
 solution 355
 Energy 15, 16
 Energy–momentum form 436
 Energy–momentum map 128
 Equality of action and reaction 11
 Equation
 of constraint 18
 of motion 3
 Ergodic hypothesis 306
 Essential resonance 237
 Euler angles 122
 Euler's formula 24
 Euler–Poincaré equations 441
 Euler–Poinsoot problem 254, 258
 Euler–Poisson equations 26, 458
 Exchange in final motions 84
 Exchange of intervals 397, 398
 Extended configuration space 103

 Fast variables 208
 Final class of motions 84
 Final motions 84
 Fixed centres 394
 Floquet form of a system 298
 Floquet matrix 298
 Force 4
 of interaction 11
 of viscous friction 426
 Force function 16
 Forces of inertia 12

- Frame of reference 10
- Free canonical transformation 33
- Frenet formulae 5
- Frequency 175
- Frobenius' criterion for complete integrability 29
- Frozen-in direction field 432
- Frozen-in family of integral curves 431
- Fuchs equations 459
- Fundamental problem of dynamics 256

- Gajdukov's theorem 393
- Galilean group 9
- Galileo's principle of relativity 9
- Galileo–Newton
 - law of inertia 11
 - principle of relativity 10
- Gauss'
 - averaging 259
 - principle 28
 - problem 259
- Generalized action–angle variables 182
- Generalized force 18
- Generating function 33
- Generator 269
- Geodesic flow 453
- Geodesically convex submanifold 394
- Geometric adiabatic phase 327
- Geometric theorem 357
- Gevrey class 218
- Grobman–Hartman theorem 369
- Guiding-centre theory 318
- Guiding-centre transformation 320
- Gyroscopic force 114

- Hölder's principle 29
- Halo orbit 313
- Hamilton's
 - canonical equations 31
 - equation 31
 - principle 19
- Hamilton–Jacobi equation 192, 463
- Hamiltonian system
 - with constraints 48
- Hamiltonian system of rays 462
- Hamiltonian vector field 30
- Hannay angle 327
- Hannay's hoop 329
- Harmonic oscillator 3
- Helmholtz' theorem 41
- Helmholtz–Thomson theorem 449, 464
- Heteroclinic motion 168
- Heteroclinic solution 370
- Hidden motion 115
- Hill region 87
- Hill's problem 89
- Holonomic system 29
- Holonomy group 331
- Homeoid density 98
- Homoclinic
 - motion 168
 - solution 370
 - trajectory 288
- Homographic solution 80
- Homothetic solution 81
- Horizontal path 113
- Hyperbolic
 - in the future solution 375
 - invariant torus 302
 - motion 83
 - solution 355
- Hyperbolic-elliptic motion 83
- Hyperbolic-parabolic motion 83

- Improved adiabatic invariant 346
- Independent functions 352
- Inertia
 - axes 24
 - forces 12
 - operator 24
- Inertial force 13
- Inertial frame of reference 10
- Integral
 - form 434
 - invariant 39, 433, 436, 438
 - manifold 128
- Integrating factor 199
- Integration operator 213
- Interaction force 11
- Interval exchange 397, 398
- Invariant
 - measure 199
 - plane 17
 - torus 222, 441
- Island of perpetual adiabatic invariance 349

- Isoenergetically non-degenerate
 - Hamiltonian system 273, 295
- Isolated solution 354
- Isotropic manifold 298
- Isotropy 297
- Ivory's theorem 98
- Ivory–Newton theorem 101
- Jacobi
 - elliptic coordinates 194
 - identity 31
 - integral 87
 - metric 138
- KAM theory 270, 273
- Kepler's
 - equations 68
 - first law 64
 - problem 64
 - second law 62
 - third law 65
- Key set 352
- Kinetic energy 15
- Kirchhoff's equations 26
- Kirkwood gap 251, 349
- Kolmogorov
 - set 274
 - theorem 200, 274
 - tori 274
- Kovalevskaya exponents 458, 461
- Kovalevskaya matrix 458
- Kummer systems of rays 462
- Lagrange
 - equation 19
 - function 19
 - multipliers 43
 - problem 42
 - stability 267
 - theorem 41, 81, 463
- Lagrange–Cauchy integral 463
- Lagrangian
 - derivative 21
 - manifold 304
 - motion 261
 - submanifold 298
 - surface 361
 - system 19
 - system with constraints 27
- Lagrangian 19
- Lamb's equation 461, 463
- Laplace operator 313
- Laplace vector 261
- Laplace–Lagrange theorem 260
- Laplacian invariant plane 17
- Larmor motion 320
- Larmor radius 6
- Law of inertia 11
- Law of universal gravitation 4
- Lazutkin's formula 283
- Left-invariant vector field 23
- Legendre transform 34
- Leibnitz rule 31
- Libration 145
- Libration point 312
- Libration points 87
- Lidov–Kozai resonance 260
- Lie algebra 23, 105, 117, 198, 277, 441, 458
- Lie group 23, 105, 109, 441, 467
- Limit cycle 219
- Lindstedt series 267
- Lindstedt's method 265
- Liouville
 - equation 438
 - measure 438
 - theorem 40
- Lorentz force 6
- Lorenz system 151, 251
- Lower-dimensional torus 297
- Lyapunov stability 296
- Magnetic
 - field 101, 311, 318
 - moment 320
 - traps for plasma 322
- Magnetosphere 251, 349
- Malus' theorem 462
- Mass of a point 3
- Material point 3
- Mathematical pendulum 28
- Mathieu's equation 340
- Maupertuis action 137
- Maxwell equations 6
- Mean anomaly 68
- Mean longitude 260
- Method
 - of coding trajectories 380

- of successive changes of variables 215
- Moment
 - of force 15
 - of force relative to a group 107
 - of inertia 15, 24
 - of momentum 15
- Momentum 15
- Momentum map 106
 - for a group action 106
 - for Poisson action 111
 - of a vakonomic system 109
- Monge–Ampère equation 438
- Morse function 429
- Motion 1
 - of a Lagrangian system 22
 - of a Hamiltonian system 48
 - of a Lagrangian system with constraints 27
 - of a rigid body in ideal fluid 189
- Moulton’s theorem 80
- Multi-frequency system 214, 324
- Multipliers 43, 354
- Multivalued integral 455

- n*-body problem 72, 260, 311
- Nötherian integrals 467
- Nambu system 253
- Natural equations of motion 5
- Near-identity map 225
- Negative-definite function 162
- Nekhoroshev’s theorem 291
- Newton’s
 - equation 3
 - equations 4
 - theorem 98
- Newton–Ivory theorem 101
- Newton–Laplace principle of determinacy 2
- Non-autonomous resonant Birkhoff
 - normal form 419
- Non-commutative integrability 185
- Non-degenerate
 - equilibrium 429
 - equilibrium position 220
 - Hamiltonian system 181, 273, 295
 - map 294
 - periodic solution 355
 - system 443
- Non-holonomic system 29
- Non-integrability 399
- Non-resonant
 - domain 229
 - torus 175, 273
 - transformation 389
- Normal
 - form 406, 408, 419
 - form of a series 177
 - frequency 301, 403
 - mode 403
- Not hampered vector field 117
- Number of degrees of freedom 19

- Observable function 47
- Optical waveguide 323
- Orbit 1
- Order of resonance relation 406
- Oscillating in the future solution 375
- Oscillating motion 83
- Oscillator 3
- Over-barrier reflection 335

- Palais–Smale condition 168
- Palais–Smale sequence 168
- Parabolic
 - coordinates 197
 - in the future solution 375
 - motion 83
- Parabolic-elliptic motion 83
- Partial averaging 210
- Partially averaged system 210
- Path 1
- Pendulum 28
 - form of a system 233
 - with vibrating suspension point 220
- Pericentre 63
- Periodic trajectory 136, 145
- Perpetual adiabatic invariance 349
- Perpetual adiabatic invariant 340
- Perturbation theory 207
- Phase space 2, 116
- Planar restricted 3-body problem 257, 262, 311
- Plasma 322
- Poincaré
 - elements 260
 - integral 364
 - return map 272, 348

- set 352
- theorem 385
- Poincaré–Birkhoff geometric theorem 357
- Poincaré–Cartan integral invariant 39, 436
- Poincaré–Mel’nikov formula 284, 292
- Poincaré–Mel’nikov integral 364
- Poisson
 - action 110
 - bracket 31
 - stable motion 93
- Polar symplectic coordinates 405
- Polyintegrable system 253
- Possible motion 16, 129, 136
- Potential 16
- Potential energy 16
- Potential trough 317
- Primary constraints 50
- Primary homoclinic motion 169
- Primitive function 32
- Principal
 - frequency 403
 - inertia axes 24
 - oscillation 403
- Principle
 - of determinacy 2
 - of equality of action and reaction 11
 - of relativity 9, 10
 - of stationary action 19
- Probability of capture
 - into domain 249, 255
 - into resonance 230, 235
- Problem
 - of n fixed centres 394
 - of motion of a rigid body in ideal fluid 189
 - of two fixed centres 196
- Proper degeneracy 258, 269
- Properly degenerate Hamiltonian system 181
- Quasi-convex function 291
- Quasi-ergodic hypothesis 306
- Quasi-homogeneity exponents 458
- Quasi-homogeneous
 - form 460
 - function 459
 - system 458
- Quasi-periodic invariant manifold 296
- Quasi-random oscillations 374
- Quasi-velocity 23
- Rüssmann non-degenerate system 277
- Rapidly rotating phase 217
- Ray systems 461, 462
- Rayleigh–Fisher–Courant theorem 403
- Reaction 11
- Reaction of constraint 18
- Rectification 105
- Reduced
 - Hamiltonian system 118
 - integral manifold 129
 - Lagrangian 120
 - Lagrangian system 112
 - phase space 118
- Reduced force function 114
- Reduced potential 62, 82
- Reducibility 297
- Reducible invariant torus 298, 441
- Redundant coordinates 47
- Reference frame 10
- Region of possible motion 16, 129, 136
- Regular Lagrangian system 162
- Regularization 70
- Regularizing variable 70
- Relative equilibrium 63, 81, 127
- Relative integral invariant 433
- Relativity principle 9, 10
- Released motion 27
- Removable degeneracy 281
- Resonance 210
 - relation 210
 - relation for periodic systems 418
 - relation for the Kovalevskaya exponents 461
- Resonant
 - Birkhoff normal form 408, 419
 - harmonic 210
 - surface 230
 - torus 175, 273
 - zone 237
- Restricted circular 3-body problem 259
- Restricted planar 3-body problem 257, 262, 311
- Return map 272, 348

- Rigid body 24
- Rotation 145
- Rotation number 222
- Routh function 112
- Routh's method 112

- Scattering on resonance 231
- Schrödinger operator 313, 327
- Secondary constraints 50
- Secondary homoclinic motion 169
- Secular terms 267
- Separable variables 192
- Separatrices 232, 357
- Single-frequency system 217
- Slow variables 208
- Slow-fast system 345
- Small
 - denominators 213, 266, 381
 - divisors 213
 - oscillations theory 401
- Splitting of asymptotic surfaces 362
- Splitting of separatrices 282
- Stability
 - of equilibrium 416, 422
 - of the Solar System 260
- Stable motion 72
 - in the sense of Poisson 93
- Standard map 285
- State space 2
- Stationary action 19
- Stationary motion 127
- Steep function 289
- Steepness condition 289
- Stokes' formula 39
- Stokes' law 4
- Strong incommensurability 226, 297
- Strong resonance 238
- Successive changes of variables 215
- Superconvergence 270
- Surfatron acceleration 324
- Symbolic dynamics 380
- Symmetry field 103, 432
- Symmetry group 103, 106
 - of a non-holonomic system 107
 - of a vakonomic system 109
- Symplectic
 - action of a group 110
 - atlas 32
 - basis 389
 - coordinates 30
 - map 294
 - polar coordinates 405
 - structure 30
- System of rays 461, 462

- Theorem on rectification 105
- Theory of small oscillations 401
- Thomson's theorem 463
- Three-body problem 257, 259, 262, 311
- Time axis 1
- Toda's chain 198
- Topological instability 287
- Torque 15
- Total dissipation 54
- Trajectory 1
- Transfer acceleration 13
- Transition chain 287
- Transversal homoclinic motion 169
- Trapping condition 317
- Traps for plasma 322
- Trivial direction field 446
- True anomaly 67
- Tube of trajectories 38
- Twist map 308
- Two fixed centres 196
- Two-body problem 61
- Two-frequency system 237

- Uniform mean condition 228
- Unimodular Lie group 442
- Uniqueness set 352
- Universal gravitation 4
- Universal integral invariant 436

- Vakonomic mechanics 41
- Vakonomic system 109
- Van der Pol equation 220
- Variation of a functional 21
- Variation of a path 20, 42
- Variation vector field 21
- Variational principle for invariant tori 307
- Vector field 20
- Velocity 1
- Vibrating suspension point 220
- Virtual
 - displacement 18
 - variation 18

- velocities 18, 27
- Viscous friction 426
- Von Zeipel's method 268
- Vortex 36
 - manifold 464
 - vector 464
- Waveguide 318
- Weak resonance 238
- Weakly non-holonomic system 444
- Wild resonance 261
- Work 15
- Yang-Mills equations 391