



# Problems for Algebra-Based College Physics I & II

Including Hints and Solutions

Ulrich Zürcher

Ulrich Zurcher

# **Problems for Algebra-Based College Physics I & II**

including Hints and Solutions



Problems for Algebra-Based College Physics I & II: including Hints and Solutions

1<sup>st</sup> edition

© 2015 Ulrich Zurcher & [bookboon.com](http://bookboon.com)

ISBN 978-87-403-0935-5

# Contents

	<b>Preface</b>	<b>6</b>
	<b>Formulas and Constants</b>	<b>8</b>
	<b>Problems</b>	<b>16</b>
<b>1</b>	<b>Mechanical Systems</b>	<b>16</b>
<b>2</b>	<b>Fluids and Thermal Systems</b>	<b>38</b>
<b>3</b>	<b>Electricity and Magnetism</b>	<b>47</b>
<b>4</b>	<b>Waves, Sound, and Light</b>	<b>61</b>
<b>5</b>	<b>Modern Physics</b>	<b>73</b>
	<b>Hints</b>	<b>78</b>

I joined MITAS because  
I wanted **real responsibility**

The Graduate Programme  
for Engineers and Geoscientists  
[www.discovermitas.com](http://www.discovermitas.com)



**Month 16**

I was a construction  
supervisor in  
the North Sea  
advising and  
helping foremen  
solve problems

Real work  
International opportunities  
Three work placements



 **MAERSK**



Click on the ad to read more

	<b>Solutions</b>	<b>90</b>
<b>1</b>	<b>Mechanical Systems</b>	<b>90</b>
<b>2</b>	<b>Fluids and Thermal Systems</b>	<b>147</b>
<b>3</b>	<b>Electricity and Magnetism</b>	<b>169</b>
<b>4</b>	<b>Waves, Sound, and Light</b>	<b>202</b>
<b>5</b>	<b>Modern Physics</b>	<b>233</b>



www.job.oticon.dk

**oticon**  
PEOPLE FIRST



## Preface

Learning a new language begins with simple declarative sentences: “The house is tall;” or “The train leave New York Penn Station at 9:18 am for Boston.” Mastery of a language means that one understands more complex sentences with relative clauses, or that one can carry a conversation which frequently involves grammatically incorrect phrases. Learning physics is similar.

The analog of a declarative sentence is a “one-step problem:” Given the (net) force  $F = 13.0\text{ N}$  acting on a block with mass  $m = 4.2\text{ kg}$ , find the acceleration of the block.” The solution is straightforward: one finds  $a = F/m = (13.0\text{ N})/(4.2\text{ kg}) = 3.1\text{ m/s}^2$ . In *Bloom’s Taxonomy*, one-step problems test “Knowledge” and “Comprehension.” More challenging problems correspond to the middle rung: Students must “use abstraction in (...) concrete situation” and “break down the problems into its constituent elements such that the hierarchy between ideas is made clear (...).” In a next step, these ideas are “[put] together (...) to form a whole.”

Many students often struggle with more complex problems; they cannot identify the proper physics principle that applies to a particular situation. For example, it is not clear to them whether to apply Newton’s second law, the conservation of energy, or the conservation of (linear) momentum. In standard textbooks, end-of-chapter are organized in chapters and sections (“conservation of linear momentum,” “work-kinetic energy theorem,” etc). There are few end-of-chapter problems where different concepts are combined.

I teach at a comprehensive public university, and this collection reflects my experience. A significant fraction of my students has never taken any physics course and their mathematics skills are “rusty.” I would find it unrealistic for my students to first find symbolic solutions of problems, and only insert numerical values in a last step. Therefore, exam problems for my algebra-based introductory physics course are *numerical*, and the problems in this collection mirrors this choice.

This is a compromise, and I recognize, of course, that some physical insight is easily lost this way. Another compromise deals with the context of the problems. Students in my *College Physics* are mostly in pre-med/dental/vet tracks or are majoring in biology, and health science. It is important for these students to discuss application of physics to realistic problems from biology and medicine, but I limit these context-rich examples to my lectures since they easily become too challenging especially for students who have not taken the pre-requisite (general and organic) chemistry, biology, and perhaps physiology classes. On the other hand, I expect my students to incorporate multiple physics concepts in a single problems.

This book grew out from my collection of exam problems, and were only slightly modified: they tend to be the *challenge* problems. I generally avoid using “energy” or “work” in problems that are based, e.g., on the conservation of energy or the work-kinetic energy theorem. For the most part, the physical systems and numerical values are chosen to be realistic. This is challenging for *Electricity & Magnetism* problems since a nano- (and most certainly micro-) Coulomb charges are enormous; it is difficult to find realistic systems that combine electric and mechanical forces (the familiar Millikan experiment is the exception rather than the rule). The numerical values are chosen to avoid accidental cancellations and “round” values: that is, the mass of a block is not 1 kg, forces are not 100 N, etc. A general-purpose calculator is sufficient and a graphing calculator is not needed (however, one problems requires a program such as *Excel*). Frequently used values [e.g., the mass of

an electron, the speed of light, etc] are not repeated in individual problems and are included in the collection of formulas. Other values, e.g., the specific heat of water, are given in individual problems. Unless specified, we always assume that air resistance can be ignored for projectile motion and free-fall. The solutions are fairly detailed; in general only one solution is given, although in many cases more than one solution is possible.

I expect (*and hope!*) that some readers (especially teachers) disagree with some of my choices; I would welcome a greater variety of books and collection of problems. They should become available since publishers such as *Bookboon* have greatly lowered the barriers for publications.

This book is dedicated to my students at *Cleveland State University*; they challenge me to think "creatively" and come up with "fun" problems for introductory physics.

Cleveland, OH  
March, 2015

## Formulas and Constants

### Vector:

Components of a vector:  $\vec{A} = A_x\hat{x} + A_y\hat{y}$ , where  $\hat{x}$  and  $\hat{y}$  are the unit vectors

The components of a vector can be written:  $A_x = A \cos \theta$  and  $A_y = A \sin \theta$ , where  $\theta$  is the angle with the positive  $x$ -axis [in *counter*-clockwise direction].

Vector addition. The vector  $\vec{C} = \vec{A} + \vec{B}$  has components:  $C_x = A_x + B_x$  and  $C_y = A_y + B_y$ .

### Graphs:

Slope is defined as *rise over run*.

### Motion in One Dimension:

Displacement  $\Delta x = x_1 - x_0$

average velocity:  $v_{\text{ave}} = \Delta x / \Delta t = (x_1 - x_0) / (t_1 - t_0)$

average acceleration:  $a_{\text{ave}} = \Delta v / \Delta t = (v_1 - v_0) / (t_1 - t_0)$ .

For constant acceleration  $a$ :  $v = v_0 + at$  and  $x = x_0 + v_0t + \frac{1}{2}at^2$ .

Here  $x_0$  and  $v_0$  are the position and velocity at time  $t = 0$ , respectively.

Eliminate time  $t$ :  $v^2 = v_0^2 + 2a(x - x_0)$ .

### Free Fall:

Time dependence:  $v_y = v_{y0} - gt$ , and  $y - y_0 = v_{y0}t - \frac{1}{2}gt^2$ .

Eliminate time:  $v_{y0}^2 - v_y^2 = 2g\Delta y$ .

Here,  $g = 9.8 \text{ m/s}^2$  is the acceleration due to gravity.

### Motion in Two Dimensions:

Horizontal  $x$  and vertical components  $y$ :  $\vec{r} = x\hat{x} + y\hat{y}$

average velocity:  $\vec{v}_{\text{ave}} = \Delta \vec{r} / \Delta t = (\vec{r}_1 - \vec{r}_0) / (t_1 - t_0)$

average acceleration:  $\vec{a}_{\text{ave}} = \Delta \vec{v} / \Delta t = (\vec{v}_1 - \vec{v}_0) / (t_1 - t_0)$ .

### Projectile Motion:

Initial velocity  $\vec{v}_0$ :  $v_{0,x} = v_0 \cos \theta_0$  and  $v_{0,y} = v_0 \sin \theta_0$  along horizontal and vertical [*up!*]:

$$\begin{aligned} v_x &= v_{x0} & x &= x_0 + v_{0,x}t \\ v_y &= v_{y0} - gt, & y &= y_0 + v_{0,y}t - \frac{1}{2}gt^2. \end{aligned}$$

### Dynamics and Newton's Laws:

Newton's second law:  $\vec{F} = m\vec{a}$ .

Normal force  $\vec{F}_N$  is perpendicular to the surface.

Kinetic friction:  $f_k = \mu_k F_N$

maximum static friction:  $f_{s,\text{max}} = \mu_s F_N$ .

Here,  $\mu_k$  and  $\mu_s$  are the coefficients of kinetic and static friction, respectively.

Uniform circular motion: Speed  $v = 2\pi r / T$ .

Centripetal acceleration:  $a_c = v^2 / r$  [magnitude], directed towards center.

Centripetal force  $F_c = ma_c$



### Work and Energy:

Work done by a force:  $W = Fs \cos \theta$ , where  $\theta$  is the angle between force and displacement.

Kinetic energy:  $\text{KE} = mv^2/2$

Work- Kinetic Energy Theorem:  $W = \text{KE}_f - \text{KE}_0$ .

Gravitational potential energy:  $\text{PE} = mgh$  (or  $mgy$ )

Work and energy have units  $[W] = [\text{KE}] = [\text{PE}] = 1 \text{ J}$  (Joule).

Work done by gravitational force:  $W_{\text{gravity}} = -\Delta\text{PE} = mgh_0 - mgh_f$

Conservation of mechanical energy if nonconservative forces are zero:  $E = \text{KE} + \text{PE} = \text{const.}$

Work done by nonconservative, e.g., friction, force:  $W_{\text{nc}} = E_{\text{mech},f} - E_{\text{mech},i}$ .

Power is work per time:  $P = W/t$ ; Units  $[P] = 1 \text{ J/s} = 1 \text{ W}$  (Watts).

### Linear Momentum:

Momentum:  $\vec{p} = m\vec{v}$ .

System of masses: total mass  $M = m_1 + m_2 + \dots$

Center of mass in 2 dimensions:

$$x_{\text{cm}} = \frac{m_1x_1 + m_2x_2 + \dots}{m_1 + m_2 + \dots} \quad y_{\text{cm}} = \frac{m_1y_1 + m_2y_2 + \dots}{m_1 + m_2 + \dots}$$

Total momentum of a system of masses:  $\vec{P} = \vec{p}_1 + \vec{p}_2 + \dots = M\vec{v}_{\text{cm}}$

For an isolated system [ie., no external forces]: total momentum is constant  $\vec{P} = \text{const.}$

Impulse:  $\vec{J} = \vec{F}_{\text{av}}\Delta t$ , where  $\vec{F}_{\text{ave}}$  is the average force.

Impulse- momentum theorem:  $\vec{J} = \Delta\vec{P}$ .

### Rotations:

Arc length:  $s = r\theta$  with  $[\theta] = \text{rad}$

Average angular velocity  $\bar{\omega} = \Delta\theta/\Delta t$ :  $\omega > 0$  if counterclockwise and  $\omega < 0$  if clockwise.

average angular acceleration:  $\bar{\alpha} = \Delta\omega/\Delta t$

For  $\alpha = \text{const.}$ :  $\alpha$  is constant:  $\omega = \omega_0 + \alpha t$ ,  $\theta = \theta_0 + \omega_0 t + \frac{1}{2}\alpha t^2$ ,  $\omega^2 = \omega_0^2 + 2\alpha\Delta\theta$ .

Tangential velocity:  $v_t = r\omega$  (with  $\omega$  in rad/s).

Torque produced by force:  $\tau = Fl$ , where  $l$  is the lever arm - same sign convention as  $\omega$ .

Rigid objects in mechanical equilibrium:  $\sum F_x = 0$ ,  $\sum F_y = 0$ ,  $\sum \tau = 0$

Moment of inertia:  $I = \sum mr^2$  (units  $[I] = \text{kg m}^2$ ):  $\sum \tau = I\alpha$ .

Work done by torque:  $W = \tau\theta$

Kinetic energy:  $\text{KE} = I\omega^2/2$ .

Angular momentum:  $L = I\omega$ ;  $\Delta L/\Delta t = \tau$

If not net external torque:  $\sum \tau = 0$ , then  $L = \text{const.}$

### Oscillations:

Hooke's law:  $F = -kx$ , where  $k$  is the spring constant (units  $[k] = \text{N/m}$ )

Potential energy:  $\text{PE} = kx^2/2$ .

Harmonic motion: equation of motion:  $a = -(k/m)x = -\omega^2x$  with  $\omega = \sqrt{k/m}$

Period of oscillation:  $T = 2\pi/\omega$ , frequency  $f = 1/T = \omega/2\pi$

Simple pendulum (mass attached to a string with length  $L$ ):  $T = 2\pi\sqrt{L/g}$

Displacement:  $x(t) = A \cos(\omega t)$ , velocity  $v(t) = -A\omega \sin \omega t$ ,

acceleration:  $a(t) = -A\omega^2 \cos \omega t$ ; maximum values  $v_{\text{max}} = \omega A$  and  $a_{\text{max}} = \omega^2 A$ .

**Fluids:**

Pressure:  $P = F/A$  (units  $[P] = \text{N/m}^2 = \text{Pa}$ )

hydrostatic pressure:  $P_2 = P_1 + \rho gh$ .

Archimedes principle: magnitude of buoyant force equals to weight of displaced fluid

Mass flow:  $\Delta m/\Delta t = \rho Av$ , Volume flow rate:  $\Delta V/\Delta t = Av$

Equation of continuity:  $\rho_1 A_1 v_1 = \rho_2 A_2 v_2$ .

Bernoulli equation:  $P_1 + \frac{1}{2}\rho v_1^2 + \rho g y_1 = P_2 + \frac{1}{2}\rho v_2^2 + \rho g y_2$ .

**Thermodynamics:**

Absolute zero temperature: 0 K, or  $T = -273.15^\circ\text{C}$

Temperature difference:  $\Delta T = 1^\circ\text{C} = 1\text{ K} = \frac{9}{5}^\circ\text{F}$ .

Specific heat  $c$ :  $Q = mc\Delta T$

Latent heat  $L$ :  $Q = mL$

Stefan-Boltzmann law: Intensity  $S = P/A = \epsilon\sigma T^4$  blackbody radiation for  $\epsilon = 1$ .

Ideal gas law:  $PV = nRT$ , where  $n$  is the number of molecules

Alternatively,  $PV = Nk_B T$ , where  $N$  is the number of molecules.

Kinetic theory of gases. For a molecule with mass  $m$ :  $\overline{KE} = mv_{\text{rms}}^2/3 = (3/2)kT$

Internal energy of ideal gas  $U = (3/2)nRT$  [monatomic] and  $U = (5/2)nRT$  [diatomic]

First law of thermodynamics.  $\Delta U = Q - W$

$Q > 0$  if heat added to the system;  $Q < 0$  if heat removed from the system

$W > 0$  if work is done by system,  $W < 0$  if work is done on system.

Isobaric process  $P = \text{const}$ :  $W = P(V_f - V_i)$ .

Isothermal process  $T = \text{const}$ :  $W = nRT \ln(V_f/V_i)$ .

Adiabatic process ( $Q = 0$ ):  $W = (3/2)nR(T_i - T_f)$ .

### Waves:

Frequency  $f$  and wavelength  $\lambda$ : wave speed  $v = \lambda f$

For a string of linear mass density  $m/L$  and tension  $F$ :  $v = \sqrt{F/(m/L)}$

For surface water waves  $v = \sqrt{gd}$ , where  $d$  is the depth of water.

Power  $P$  and intensity  $I$  of wave:  $I = P/A$ , where  $A$  is surface area, e.g.,  $A = 4\pi r^2$

Doppler effect:  $f_s$  frequency from source and  $f_o$  observed frequency.

Moving source:

$$f_o = f_s \left( \frac{1}{1 \pm v_s/v} \right),$$

where “+” of source moves *away* observer and “-” if source moves *towards* from observer.

Moving observer:

$$f_o = f_s \left( 1 \pm \frac{v_o}{v} \right),$$

where “+” if observer moves *toward* source and “-” of observer moves *away* from source.

Approximation for  $v_{o,s} \ll v$ :  $\Delta f/f_s = \pm v_{o,s}/v$  (“+” when source/observer move towards each other and “-” when source/observer recede from each other).

Two sources vibrating in-phase (out-of-phase), path lengths  $l_{1,2} = vt_{1,2}$ .

constructive (destructive) interference:  $\Delta l = |l_1 - l_2| = n\lambda$  with  $n = 0, 1, 2, \dots$

destructive (constructive) interference:  $\Delta l = |l_1 - l_2| = (n + 1/2)\lambda$  with  $n = 0, 1, 2, \dots$

Diffraction single slit:  $\sin \theta = \lambda/D$ , where  $\theta$  is the angle to first minimum.

Standing waves:

String with length  $L$  fixed at both ends:  $f_n = n(v/2L)$  with  $n = 1, 2, 3, \dots$

Tube with length  $L$  with one end open and other closed:  $f_n = n(v/4L)$  with  $n = 1, 3, 5, \dots$

### Electric Forces and Electric Fields:

Elementary charge  $e = 1.602 \times 10^{-19}$  C

Charge of an electron  $q_e = -e$  and charge of a proton  $q_p = +e$

Charges are “quantized:”  $Q = Ne$ , where  $N = 0, \pm 1, \pm 2, \dots$

Coulomb force: like charges repel and unlike charges attract.

Force directed along the line connecting the two charges

Magnitude of Coulomb force between charges  $q_1$  and  $q_2$  separated by distance  $r$ :

$$F = k \frac{|q_1| \cdot |q_2|}{r^2}, \quad k = 8.99 \times 10^9 \frac{\text{N m}^2}{\text{C}^2}.$$

Force on a charge  $q$ :  $\vec{F} = q\vec{E}$ .

Parallel capacitor with surface charge density  $\sigma = Q/A$ :  $E = \sigma/\epsilon_0$ .

Potential  $V = \text{EPE}/q_0$

Potential due to a point charge  $q$ :  $V = kq/r$ .

Relationship between electric field and potential  $E = -\Delta V/\Delta s$

Dielectric constant  $\kappa = E_0/E$  with  $\kappa \geq 1$ ;  $\kappa \simeq 1$  for air.

Capacitance  $C = Q/V$

Parallel plate capacitor:  $C = \kappa\epsilon_0 A/d$  ( $A$ : area and  $d$ : separation)

Electric field inside parallel plate capacitor:  $E = V/d$

Energy stored in capacitor:  $U = (1/2)CV^2$

Energy density of electric field:  $u = U/\text{Vol} = (1/2)\epsilon_0 E^2$ .

Capacitors in series:  $1/C_{\text{eq}} = 1/C_1 + 1/C_2 + \dots$

Capacitors in parallel:  $C_{\text{eq}} = C_1 + C_2 + \dots$

### Electric Currents:

Current  $I = \Delta q/\Delta t$ . Units  $[I] = 1 \text{ A} = 1 \text{ C/s}$

Ohm's law:  $V/I = R = \text{const.}$  Units  $[R] = 1 \text{ V/A} = 1\Omega$

Power dissipated in resistor  $R$ :  $P = IV = I^2R = V^2/R$ .

Resistors in series;  $R_{\text{eq}} = R_1 + R_2 + \dots$

Resistors in parallel:  $1/R_{\text{eq}} = 1/R_1 + 1/R_2 + \dots$

Kirchhoff's rules: (1) *junction*:  $\sum I_{\text{in}} = \sum I_{\text{out}}$  (2) *loop*:  $\sum V_{\text{batt}} = \sum V_R$

$RC$ -circuit:  $q(t) = q_0 \exp(-t/\tau)$ ; time constant  $\tau = RC$ .

# INNOVATIVE LIKE YOU.

If you're hoping for a truly modern education, one where you're encouraged to speak your mind and to think long-term, both when it comes to your own future and the future of the planet. Then the University of Gothenburg is the place for you.

Study a Master's programme in Gothenburg, Sweden | [www.gu.se/education](http://www.gu.se/education)



Click on the ad to read more

### Magnetic Fields:

Force on moving charge  $F = qvB \sin \theta$  ( $\theta$  angle between velocity  $\vec{v}$  and magnetic field  $\vec{B}$ )

Direction of magnetic force: [right-hand rule]

Magnetic field  $B$  with units  $[B] = 1 \text{ (Ns)/(C m)} = 1 \text{ T}$

magnetic force on wire with length  $L$ :  $F = ILB \sin \theta$

Magnetic field produced by long straight wire:  $B = \mu_0 I / 2\pi r$ , where  $r$  is the radial distance.

Direction of magnetic field lines: counter-clock wise [right hand rule]

Magnetic field at the center of a current loop with radius  $R$ :  $B = \mu_0 NI / 2R$ .

Magnetic field inside a solenoid:  $B = \mu_0 nI$  ( $n = N/L$  number of turns per unit length)

Motional EMF:  $\mathcal{E} = vBl$

Magnetic flux:  $\Phi = BA \cos \phi$

Induced EMF:  $\mathcal{E} = -\Delta\phi / \Delta t$ .

Self inductance  $L$ :  $\mathcal{E} = -L\Delta I / \Delta t$ .

Magnetic energy  $U = LI^2 / 2$  LC-circuit: resonance frequency  $f = 1 / 2\pi\sqrt{LC}$

Magnetic energy density:  $u = U / \text{Vol} = B^2 / 2\mu_0$ .

### Electromagnetic Waves:

$\vec{E} \perp \vec{B}$  and both are perpendicular to the direction of propagation

Wavelength  $\lambda$  and frequency  $f$ :  $c = \lambda f$ , where  $c$  is the speed of light

energy density  $u = \epsilon_0 E^2 = B^2 / \mu_0$

rms values:  $E_{\text{rms}} = E_0 / \sqrt{2}$  and  $B_{\text{rms}} = B_0 / \sqrt{2} = E_{\text{rms}} / c$ .

Average intensity:  $\bar{S} = c\bar{u}$ , where  $\bar{u} = \epsilon_0 E_{\text{rms}}^2$ , or  $\bar{S} = c\epsilon_0 E_{\text{rms}}^2$ .

Rays are perpendicular to wave fronts

Speed of light in material  $v$ :  $n = c/v$  [index of refraction]

Reflection:  $\theta_r = \theta_i$

Snells's law:  $n_1 \sin \theta_1 = n_2 \sin \theta_2$ , where  $\theta_{1/2}$  are the angles with respect to normal

Total internal reflection when  $\theta_2 = 90^\circ$ .

### Geometric Optics:

Spherical mirror with radius of curvature  $R$ :  $f = +R/2$  [concave] and  $f = -R/2$  [convex]

Object distance  $d_o > 0$ ; image distance  $d_i > 0$  in front of mirror and  $d_i < 0$  behind mirror

Mirror equation:

$$\frac{1}{d_o} + \frac{1}{d_i} = \frac{1}{f}.$$

Object height  $h_o$  and image height  $h_i > 0$  if upright and  $h_i < 0$  if upside down

Magnification:

$$m = \frac{h_i}{h_o} = -\frac{d_i}{d_o}.$$

Focal length of lens:  $f > 0$  (converging) and  $f < 0$  (diverging)

Object distance  $d_o > 0$ ; image distance  $d_i > 0$  behind lens and  $d_i < 0$  if in front of lens

This-lens equation:

$$\frac{1}{d_o} + \frac{1}{d_i} = \frac{1}{f}.$$

Object height  $h_o > 0$  and image height  $h_i > 0$  if upright and  $h_i < 0$  if upside down

Magnification:

$$m = \frac{h_i}{h_o} = -\frac{d_i}{d_o}.$$

Eye glasses: diopters  $D = 1/f$  with  $f$  in meters.

**Interference:**

Young's double-slit experiment with wavelength  $\lambda$  and distance  $d$  between slits:

$$\sin \theta = m \frac{\lambda}{d} \text{ (bright fringes), } \sin \theta = \left(m + \frac{1}{2}\right) \frac{\lambda}{d} \text{ (dark fringes), } m = 0, 1, \dots$$

Single-slit diffraction with wavelength  $\lambda$  and width  $W$  of slit:

$$\sin \theta = m \frac{\lambda}{W} \text{ (dark fringes), } m = 1, 2, \dots$$

Diffraction grating with wavelength  $\lambda$  and distance  $d$  between neighboring slits:

$$\sin \theta = m \frac{\lambda}{d} \text{ (principal maxima), } m = 1, 2, \dots$$

Resolving "power:"  $\theta_{\min} = 1.22 \lambda/D$  [in radians]

**Special Relativity:**

Energy  $E$  - momentum  $p$ :  $E^2 = p^2c^2 + m^2c^4$

Rest energy of object when  $p = 0$ :  $E = mc^2$ .

For particles with zero mass  $m = 0$  (e.g., photons)  $E = pc$ .

**Particles and Waves:**

Photon with frequency  $f$ : energy  $E = hf$

Photoelectric effect:  $hf = KE_{\max} + W_0$ , where  $W_0$  is the work function of the metal

Compton effect:  $\lambda' - \lambda = (h/mc)(1 - \cos \theta)$

de Broglie wavelength for particle with momentum  $p = mv$ :  $\lambda = h/p$

Heisenberg uncertainty relation:  $\Delta p \Delta x \geq (h/4\pi)$  and  $\Delta E \Delta t \geq (h/4\pi)$

"Particle-in-a-box:"  $\lambda = 2L/n$  and  $E_n = h^2n^2/(8mL^2)$

For hydrogen atom: Bohr energy levels:  $E_n = -(13.6 \text{ eV})/n^2$ . Line spectrum of hydrogen:

$$\frac{1}{\lambda} = R \left( \frac{1}{n^2} - \frac{1}{m^2} \right), \quad R = 1.097 \times 10^7 \text{ m}^{-1}.$$

Lyman series  $n = 1$  and  $m = 2, 3, 4, \dots$ ; Balmer series  $n = 2$  and  $m = 3, 4, 5, \dots$ ;

Paschen series  $n = 3$  and  $m = 4, 5, 6, \dots$

**Nuclear Structure:**

Symbols  ${}^A_ZX$  with  $A$  the number of protons and neutrons and  $Z$  the number of protons

Atomic mass unit: mass of one atom of  ${}^{12}_6\text{C}$  is 12 u.

### Radioactivity:

Time constant  $\tau$  and decay constant  $\lambda = 1/\tau$ : fractional loss  $\Delta N/N = -\Delta t/\tau$

Number of radioactive isotope at time  $t$ :  $N(t) = N_0 \exp(-t/\tau)$

Half-life:  $T_{1/2} = \ln 2/\lambda$

Activity:  $A =$  number of decays per time,  $[A] = \text{Bq} = \text{s}^{-1}$ ; Curie:  $1 \text{ Ci} = 3.7 \times 10^{10} \text{ Bq}$

### Useful Constants:

Avogadro Number $N_A$	$6.022 \times 10^{23}$
Boltzmann constant $k$	$1.38 \times 10^{-23} \text{ J/K}$
Elementary charge $e$	$1.602 \times 10^{-19} \text{ C}$
Constant in Coulomb's law $k$	$8.99 \times 10^9 \text{ N m}^2/\text{C}^2$
Planck's constant $h$	$6.67 \times 10^{-34} \text{ Js}$
Mass of electron $m_e$	$9.109 \times 10^{-31} \text{ kg}$
Mass of neutron $m_n$	$1.675 \times 10^{-27} \text{ kg}$
Mass of proton $m_p$	$1.672 \times 10^{-27} \text{ kg}$
Atomic mass unit $1 \text{ u}$	$1.6605 \times 10^{-27} \text{ kg} (= 931.5 \text{ MeV})$
Electric permittivity of free space $\epsilon_0$	$8.85 \times 10^{-12} \text{ C}^2/(\text{N m}^2)$
Magnetic permeability of free space $\mu_0$	$4\pi \times 10^{-7} \text{ T m/A}$
Stefan-Boltzmann constant $\sigma$	$5.67 \times 10^{-8} \text{ J}/(\text{s m}^2 \text{ K}^4)$

### Quadratic equation

The equation  $ax^2 + bx + c = 0$  with coefficients  $a$ ,  $b$ , and  $c$  has two solutions

$$x_{\pm} = \frac{-b \pm \sqrt{b^2 - 4ac}}{2a}.$$

Sweden  
Sverige

Linköping University –  
innovative, highly ranked,  
European

Interested in Computer Science? Kick-start your career  
with an English-taught master's degree.

→ Click here!

**li.u** LINKÖPING  
UNIVERSITY



Click on the ad to read more

## PROBLEMS

### 1: MECHANICAL SYSTEMS

**Problem 1.1:** A train robber with mass  $m = 82\text{ kg}$  stands on a runaway railway cart traveling at a velocity  $v_1 = 3.2\text{ m/s}$ . He passes by a slower cart traveling at the velocity  $v_2 = 1.3\text{ m/s}$ . Each cart has the mass  $M = 253\text{ kg}$ . The tracks are parallel, and he jumps perpendicular to the tracks. Assume that the component of the velocity parallel to the tracks of the robber while in air is identical to the velocity of the cart from which he jumps. Only consider the velocities parallel to the tracks.

- He jumps to the slower car. Find the speed of the slower cart with him safely on!
- He immediately notices that his mistake and jumps back to the faster cart. Find the speed of the faster cart with him safely on it!
- He leaps off a cart in  $0.3\text{ s}$ , is in air for  $0.8\text{ s}$ , and safely lands on a cart in  $1.2\text{ s}$ . Find the forces [*vector!*] along the acting on him!
- Explain the directions of the forces in part c) [*Open ended question*].

**Problem 1.2:** A bob with mass  $m = 1.2\text{ kg}$  is attached to a string with length  $L = 0.86\text{ m}$  that, in turn, is secured to vertical pole mounted on a cart with mass  $M = 5.4\text{ kg}$ . The cart moves on frictionless wheels. The rope is pulled from the vertical and then released; the cart is initially at rest.

- The bob swings towards the vertical and reaches the velocity  $v = 1.8\text{ m/s}$ . What is the velocity of the cart at that instant?
- Find the angle  $\theta_0$  from which the bob is released!
- What is the horizontal displacement of the cart when the bob is in the vertical position?
- How long does it take for the bob return to its original position?

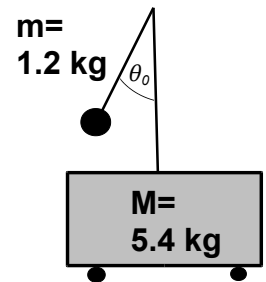

**Problem 1.3:** On the northern hemisphere, winds blow dominantly west-to-east (due to the Earth rotation). A sailboat can travel along two different routes: #1 at the angle  $\theta_1 = 38^\circ$  south-of-east and #2 at the angle  $\theta_2 = 63^\circ$  south-of-west. The speed of the sailboat is  $v_{\text{boat}} = 6.5\text{ km/h}$  for both routes. Two islands A and B are on the  $W 154^\circ$  longitude; island B is  $45\text{ km}$  south from A. The skipper starts on island A and wants to arrive at island B.

- The skipper first sails along route #1 for 2 hours and then continues along route #2. Where does she cross the  $W 154^\circ$  longitude?
- How long does the skipper stay on route #1 so that she arrives on island B?

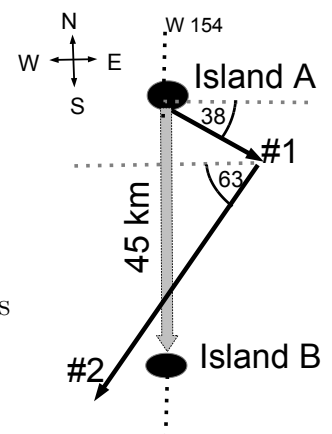



**Problem 1.4:** A tennis ball is fired from a gun mounted on the floor. The tennis ball has an initial speed  $v_0 = 25.0$  m/s and is launched at an angle of  $\theta_0 = 35^\circ$  above the horizontal. You stand 57.0 m away from the gun.

- At what time do you catch the ball? Assume that  $t = 0$  when the ball is fired.
- What is the height of the ball above ground when it reaches your racket?
- What is the *speed* of the tennis ball when it reaches your racket?

**Problem 1.5:** A 0.3-kg brick falls from a height of 8.0 m and hits the ground.

- What is the speed of brick just before it hits the ground.
- What is the impulse exerted by the ground on the brick.
- It takes 0.012 s from the moment when the brick first touches the ground until it comes to rest. What is the average force exerted by the ground on the brick.

**Problem 1.6:** A 45.0-g golf ball is hit by a club off the tee.

After the hit, the ball flies off with a speed of  $v = 19.0$  m/s.

- What is the work done by the club on the ball?
- The golf ball is *compressed* 1.2 mm while it is struck by the club. What is the average force that the club exerts on the ball?
- The ball undergoes projectile motion. The point  $P$  is at the distance  $\Delta x = 23.4$  m down the faraway, and at the height  $\Delta y = 9.6$  m above the (level) ground. What is the work done on the ball by the *gravitational force*, while the ball flies from the tee to the point  $P$ ?
- What is the *speed* of the golf ball at the point  $P$ ?

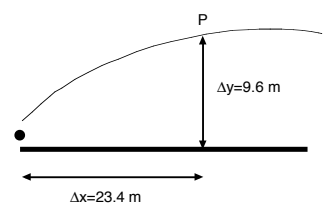

**Problem 1.7:** You throw a ball up in air from an initial height of 1.0 m above the ground. You observe that the ball just reaches the top of your house that is 15.0 m high. Consider only the vertical motion of the ball.

- What is the initial speed of the ball when it leaves your hand?
- You miss the ball when it comes down, and it falls to the ground. Find the velocity (*vector!*) of the ball before it hits the ground.
- Find the *average* velocity (*vector!*) of the ball during the entire flight.
- How long is the ball up in air?

**Problem 1.8:** The hanging block (with mass  $m_1 = 3.0$  kg) and the block (with mass  $m_2 = 5.0$  kg) sitting on the table are connected by a rope. The coefficient of kinetic friction between the block and the table is  $\mu_k = 0.24$ .

- Draw the *free-body* diagrams for the for the two blocks.
- Write down Newton's second law for the blocks.
- Find the magnitude of the (common) acceleration of the blocks.
- Find the tension in the rope.

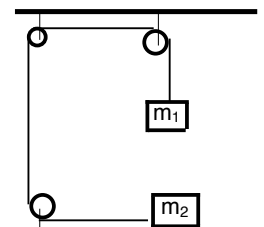

**Problem 1.9:** A uniform pole of weight  $W = 240.0 \text{ N}$  and length  $L = 5.2 \text{ m}$  is at rest on a rough  $30^\circ$  incline and is secured by a horizontal rope at its center. The pole stands perpendicular to the incline.

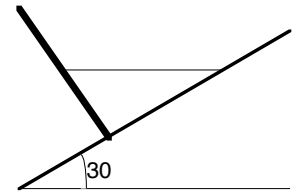

- Draw the free-body diagram for the pole.
- Write down Newton's second law for the pole.
- Choose an axis of rotation and calculate the torque about that axis.
- Find the tension in the rope.
- Find the normal force exerted by the incline on the pole.

**Problem 1.10:** A string is wrapped around a circular disk with radius  $r = 0.4 \text{ m}$ . The moment of inertia of the disk is  $I = 0.74 \text{ kg m}^2$ .

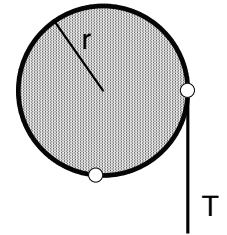

- We pull on the string with a constant force (tension)  $T = 1.4 \text{ N}$ . Find the magnitude of the torque exerted on the disk.
- The disk rotates one quarter of a revolution. What is the work done by the applied torque?
- The disk starts from rest. What is the angular speed of the disk after it has rotated one quarter of a revolution?
- How long does it take to rotate the disk by one quarter of a revolution?

**STUDY FOR YOUR MASTER'S DEGREE  
IN THE CRADLE OF SWEDISH ENGINEERING**

Chalmers University of Technology conducts research and education in engineering and natural sciences, architecture, technology-related mathematical sciences and nautical sciences. Behind all that Chalmers accomplishes, the aim persists for contributing to a sustainable future – both nationally and globally.

Visit us on [Chalmers.se](http://Chalmers.se) or **Next Stop Chalmers** on facebook.

**CHALMERS**  
UNIVERSITY OF TECHNOLOGY



Click on the ad to read more

**Problem 1.11:** A block with mass  $m = 0.5$  kg is attached to a frictionless pivot  $P$  by a cable of length  $L = 1.7$  m and negligible mass.

a) The block is pulled away from its vertical position so that it has a height  $h = 12.5$  cm.

a) How long does it take to return back to its vertical position?

b) What is the speed of the block as it passes through the vertical position?

c) What is the tension in the cable as the block passes through the vertical position?

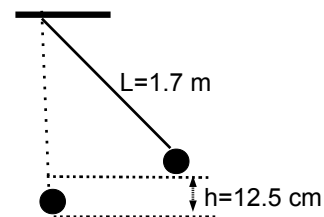

**Problem 1.12:** An object with mass  $m = 0.125$  kg glides down a frictionless bowl. The bottom of the bowl is flat.

a) The object starts from rest at the height  $h = 0.6$  m.

What is the speed of the object when it reaches the flat part?

b) At the bottom of the bowl sits another identical object.

The two objects “stick together” after the collision. What is the common speed of the two blocks?

c) The two objects then move upwards on the right side of the bowl.

Find the maximum height  $H$  on the right side of the bowl.

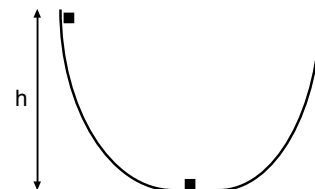

**Problem 1.13:** The vector  $\vec{A}$  has components  $A_x = -1.2$  and  $A_y = 2.7$

a) The magnitude and direction of the vector  $\vec{B}$  is  $|\vec{B}| = 6.4$  at the angle  $\theta_B = 38^\circ$  from the  $+x$ -axis. Find the magnitude and direction of the vector  $\vec{C} = \vec{A} + \vec{B}$ .

b) The vector  $\vec{D}$  is directed in the direction  $\theta_D = 49^\circ$  with respect to the  $+x$ -axis. Find the magnitude  $|\vec{D}|$  such that the sum  $\vec{E} = \vec{A} + \vec{D}$  is directed at the angle  $\theta_E = 22^\circ$  with respect to the  $+x$ -axis.

**Problem 1.14:** A football is launched from the ground of a level football field. A device inside a football keeps track of the speed [i.e., the magnitude of the instantaneous velocity]. The minimum speed of the football is  $v_{\min} = 17.4$  m/s.

a) The football hits the ground at the distance  $d = 52.8$  m from the launch point.

What is the launch speed of the football?

b) What is the launch angle of the football?

c) Find the highest point of the football above the ground.

**Problem 1.15:** John runs at the speed 6.0 m/s. Marcia runs 15% faster than John.

a) By what distance does Marcia beat John in a 100-m race?

b) By what time does Marcia beat John in a 100-m race?

c) In another 100-m race, Rob is competing against Susan. Rob beats Susan by the distance 24.5 m and the time of 16.5 s. How fast are Susan and Rob running?

**Problem 1.16:** Emmy starts from rest and runs at a constant acceleration  $a = 0.23 \text{ m/s}^2$ . Harry starts 63 m behind Emmy and runs at a constant velocity  $v_H = 4.7 \text{ m/s}$ . Harry gets close to Emmy, but does never reach or get ahead of her!

- Sketch the graph with the positions of Emmy and Harry as a function of time.
- Where is Emmy when Harry reaches Emmy's start position?
- What is the distance between Harry and Emmy at the instant when Emmy runs twice as fast as Harry?
- What is the closest distance between Harry and Emmy? Where are Harry and Emmy at that time?

**Problem 1.17:** Two blocks with masses  $m_1 = 0.97 \text{ kg}$  and  $m_2 = 1.20 \text{ kg}$  are connected by a rope that passes over a frictionless pulley. They are initially at the same height  $H = 21 \text{ cm}$  above the ground.

- What is the speed of the block  $m_1$  when the mass  $m_2$  hits the ground?
  - What is the total (or net) work done on the mass  $m_1$ ?
  - What is the work done by the tension on the block  $m_1$ ?
- Find the tension in the cable.

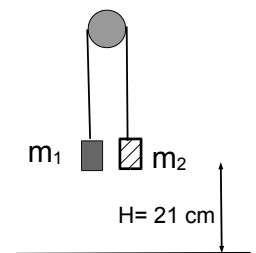

**Problem 1.18:** Three blocks with masses  $m_1 = 3.2 \text{ kg}$ ,  $m_2 = 7.4 \text{ kg}$ , and  $m_3 = 4.1 \text{ kg}$ , respectively, are sitting on a frictionless, horizontal surface. The blocks are connected by rigid rods. The force with magnitude  $|\vec{F}| = 39.0 \text{ N}$  is applied to the block at the center.

- Draw the appropriate free-body diagram(s) for this problem.
- Write down Newton's second laws for this problem!
- What is (are) the acceleration(s) of the blocks?
- What are the force(s) in the two rods connected the blocks?

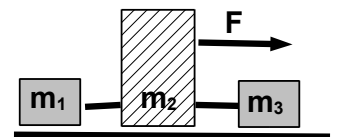

**Problem 1.19:** An opened umbrella has the shape of a cone with side length 34 cm and angle  $\theta = 16^\circ$ . A water droplet with mass  $m = 4.6 \text{ g}$  sits at the distance  $s = 14 \text{ cm}$  from the top. The coefficient of static friction between the umbrella's fabric and the rain drop is  $\mu_s = 0.78$ . We spin ["twirl"] the umbrella around the vertical.

- Draw the appropriate free-body diagram for the problem.
- Write down Newton's second law for the problem.
- How fast [e.g., number of rotations per minute] do you have to spin the umbrella so that the rain drop begins to move down the umbrella, i.e., the rain drop is dislodged?

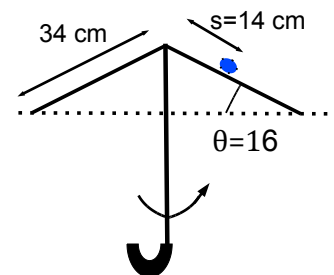

**Problem 1.20:** The Moon orbits the Earth in one (siderial) month, or 27.3 days.

- Find the distance between the Moon and the Earth.
- A (total) lunar eclipse lasts for about 60 minutes. It takes 8 minutes for the Moon to become dark during a lunar eclipse. Find the radius of the Moon. (Use  $R_E = 6380$  km for the radius of the Earth).

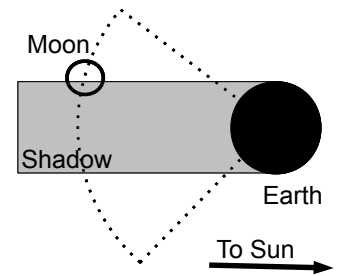

**Problem 1.21:** A board with length  $l = 1.2$  m and mass  $m = 0.3$  kg is hung by two strings attached to the end of the board and two nails (separated by  $L = 1.8$  m). A block with mass  $M = 1.3$  kg initially placed in the middle of the board [shown in the picture] is moved  $\Delta = 0.3$  m to the right. The lengths of the strings are adjusted such that the board remains horizontal at the height  $h = 0.8$  m below the nails. The board moves freely along the horizontal.

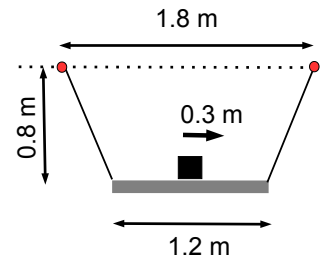

- Draw the appropriate free-body diagram(s).
- Write down Newton's second law.
- Write down the equation for the torque about the center of the board.
- Find the tensions in the strings and the horizontal displacement of the board.



**MÄLARDALEN UNIVERSITY**  
SWEDEN

**WELCOME TO OUR WORLD OF TEACHING!**  
INNOVATION, FLAT HIERARCHIES AND OPEN-MINDED PROFESSORS

**STUDY IN SWEDEN - CLOSE COLLABORATION WITH FUTURE EMPLOYERS**  
MÄLARDALEN UNIVERSITY COLLABORATES WITH MANY EMPLOYERS SUCH AS ABB, VOLVO AND ERICSSON

**TAKE THE RIGHT TRACK**  
GIVE YOUR CAREER A HEADSTART AT MÄLARDALEN UNIVERSITY

[www.mdh.se](http://www.mdh.se)

**DEBAJYOTI NAG**  
SWEDEN, AND PARTICULARLY MDH, HAS A VERY IMPRESSIVE REPUTATION IN THE FIELD OF EMBEDDED SYSTEMS RESEARCH, AND THE COURSE DESIGN IS VERY CLOSE TO THE INDUSTRY REQUIREMENTS.

HE'LL TELL YOU ALL ABOUT IT AND ANSWER YOUR QUESTIONS AT [MDUSTUDENT.COM](http://MDUSTUDENT.COM)



**Problem 1.22:** While pacing in a hallway at a constant velocity, you drop a tennis ball so that it falls towards the floor, and then catch the rebounding ball. The time between dropping and catching the ball is 1.1 s.

- Calculate the height above the floor at which the tennis ball is released.
- Counting the tiles on the floor, you calculate that you have walked 1.7 meters when you catch the tennis ball. How fast do you are pace?
- Calculate the speed of the tennis ball right before it hits ground.

**Problem 1.23:** Starting from rest, a solid sphere [mass  $m = 0.1$  kg and radius  $r = 0.21$  m] rolls down an incline with length  $s = 2.4$  m at the angle  $\theta = 22^\circ$  with the horizontal. The moment of inertia of a solid sphere about the center is  $I = (2/5)mr^2$ ; the ball rolls *without slipping*. The coefficient of static and kinetic friction between the sphere and the surface are not known.

- Calculate the speed of the center of mass and the angular speed of the ball at the end of the ramp.
- Find the linear and angular acceleration of the sphere.
- What is the friction force between the surface and the ball?
- What can we conclude about the coefficient of friction between the surface and the ball?

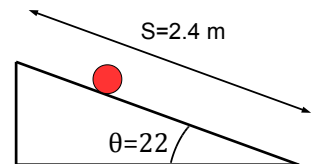

**Problem 1.24:** A bob with mass  $m = 0.34$  kg is attached to a spring with constant  $k = 4.1$  N/m. When the bob is along the horizontal, the spring is at the unstretched length 0.26 m.

- The bob is released, it swings downward and passes 1.55 m below the pivot. What is the speed of the bob at that point?
- What is the acceleration of the bob and the forces acting on it when it swings through the vertical?
- The bob-spring system slows down due to damping until the bob eventually comes to rest. Where does the bob come to a stop?
- Find the fraction *mechanical* energy that is “lost” until the bob comes to a full stop after many swings?

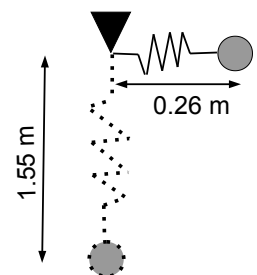

**Problem 1.25:** Harry and Emmy compete in a charity event. Emmy starts at the 0-yard [0 m] line and Harry starts at the 100-yard [91.4 m] line; they run towards the opposite side of the football field. They pass each other at the 43-yard (39.3 m) line; Emmy finishes 5.2-s after Harry.

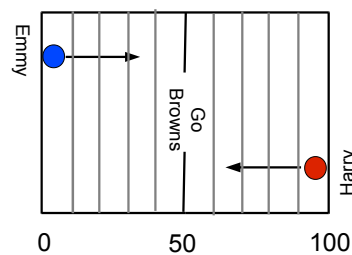

- Where is Emmy at the instant when Harry just finishes his run?
- How fast are Emmy and Harry running?

**Problem 1.26:** A block with mass  $m = 1.2$  kg sits on a wedge with mass  $M = 5.3$  kg; the incline makes the angle  $\theta = 32^\circ$  with the horizontal. A horizontal force  $F$  is applied to the wedge such that the block does not slide down the incline, i.e., the block moves along the horizontal only. There is no friction between the block and the wedge and between the wedge and the horizontal surface.

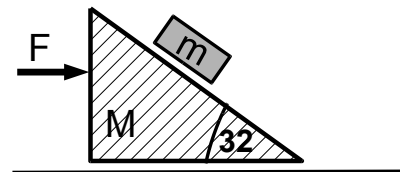

- Draw the appropriate free-body diagram(s) for this problem.
- Write down Newton's second law(s) for the problem.
- Find the magnitude of the applied force  $F$ .

**Problem 1.27:** Two blocks with masses  $m_1 = 3.5$  kg and  $m_2 = 5.0$  kg are placed on a frictionless air track. We attach a metal strip to the block with mass  $m_1$ . The two blocks collide *elastically*. The block  $m_2$  is initially at rest; the block  $m_1$  initially travels at the speed 4.2 m/s. We ignore the mass of the metal strip; the metal strip acts as a spring with constant  $k = 5.0 \times 10^3$  N/m.

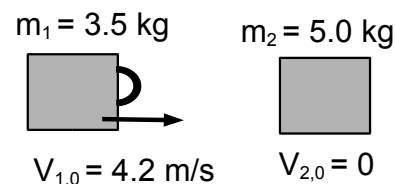

- After the collision, the block  $m_1$  rebounds and travels at the speed 0.75 m/s. What is the speed of the block  $m_2$  after the collision?
- Since the block  $m_1$  reverses direction, there is an instant when its velocity is zero  $v_1 = 0$ . How much is the spring compressed at that instant?

**Problem 1.28:** A small pearl moves back and forth near the bottom of a hemispherical bowl. The angle  $\theta$  is small enough that the object oscillates in simple harmonic motion. The pearl rolls without slipping. The radius of bowl is  $R = 12$  cm. The pearl has mass  $m = 17.6$  g and radius  $r = 0.5$  cm.

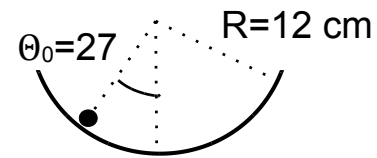

- The pearl is released from rest at the angle  $\theta_0 = 27.0^\circ$ . How fast does the pearl move horizontally at the bottom of the bowl?
- How long does it take for the pearl to reach the bottom of the bowl.

**Problem 1.29:** A board with unknown mass  $M$  is 4.0 m long; the board has uniform mass distribution. The board is supported by a cone placed 0.5-m from the right end. The board is also supported by a vertical rope at the far-left side. A block with unknown mass  $m$  is placed at 1.0-m and 1.5-m from the left-end.

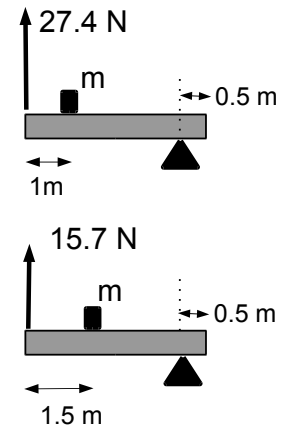

- Draw the free-body diagram for the problem!
- Write down Newton's second law for the board; choose an axis of rotation and write down the torque about that axis!
- When the block is placed 1.0-m (1.5-m) from the left-end of the board, the tension in the rope is 27.4 N (15.7 N). Find the mass of block!



## Develop the tools we need for Life Science Masters Degree in Bioinformatics

Bioinformatics is the exciting field where biology, computer science, and mathematics meet.

We solve problems from biology and medicine using methods and tools from computer science and mathematics.

Read more about this and our other international masters degree programmes at [www.uu.se/master](http://www.uu.se/master)



Click on the ad to read more



**Problem 1.30:** A squid draws water through a slit in its belly and stores water inside its mantle. The squid has a mass  $M = 0.4\text{ kg}$  with its cavity empty, and can store a mass  $m = 0.1\text{ kg}$  of water in its mantle.

- The speed of the expelled water is  $|v_w| = 3.0\text{ m/s}$ . Calculate the speed of the squid after the squirt of water. Assume that the squid is initially at rest.
- The squirt lasts for  $0.5\text{ s}$ . Calculate the magnitude of the average force that the water exerts on the squid.

**Problem 1.31:** A  $m = 0.5\text{ kg}$  block is pushed against a stationary spring on a horizontal surface. The spring has a constant  $k = 750\text{ N/m}$  and is compressed  $6\text{ cm}$  relative to its unstrained length.

- The spring is released. Calculate the speed of the block when it flies off the spring.
- The block glides along a rough surface and comes to rest after traveling a distance of  $d = 0.7\text{ m}$ . Calculate the coefficient of kinetic friction between the block and the surface.

**Problem 1.32:** Emmy [with unknown mass  $m_E$ ] stands at the center of the boat [with unknown mass  $m_B$ ]. Emmy has a dumbbell [with mass  $M = 10\text{ kg}$ ] in her hands. The boat has a length  $L = 3.2\text{ m}$ . Assume that the boat has uniform mass distribution. She throws the dumbbell to the stern (rear) of the boat. As a result, the boat moves  $5.0\text{ cm}$  towards the right. Emmy then walks to the stern and the boat moves an additional  $21.0\text{ cm}$  to the right.

- What is the combined mass of the boat and Emmy?
- What are mass of Emmy  $m_E$  and the boat  $m_B$ ?

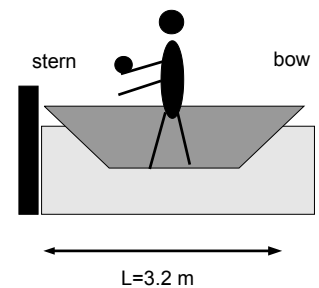

**Problem 1.33:** A block with mass  $M = 1.1\text{ kg}$  sits on a frictionless, horizontal surface and is attached to a spring with constant  $k = 13.0\text{ N/m}$ . The spring is unstrained. A piece of sticky clay is thrown against the block. The mass  $m$  of the clay and its speed  $v$  are unknown. The clay sticks to the block. The block then travels the distance  $d = 6.7\text{ cm}$  in the time  $t = 0.52\text{ s}$  until it comes to a momentary stop.

- What is the mass of the clay?
- What is the speed of the clay *before* it sticks to the block?

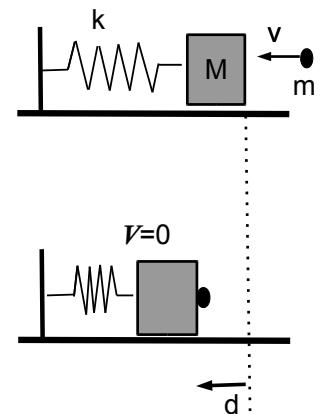

**Problem 1.34:** A metal ring of mass  $m = 0.12$  kg and radius  $r = 0.8$  cm rolls without slipping on a roller-coaster track as shown. The radius of the loop is  $R = 42$  cm. The moment of inertia of the ring is  $I = mr^2$ .

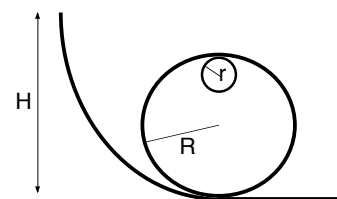

- The ring starts from rest at the height  $H = 1.54$  m. What is the speed of the ring when the ring is near the top of the loop?
- Find the force exerted by the track on the ring when it is near the top of the loop! Does the ring stay on the track?

**Problem 1.35:** A wheel with radius  $R = 0.23$  m and mass  $M = 1.2$  kg is rolling down an incline plane. The moment of inertia of the wheel is  $I = MR^2$ , and the wheel rolls without slippage. The angle  $\phi$  of the incline is unknown. The wheel begins to roll down from rest.

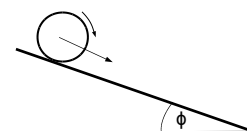

- After 6.3 seconds the wheel rotates at the rate of 394 rpm. How many times does the wheel rotate during that time?
- Find the distance traveled along the incline.
- What is angle  $\phi$  of the incline?

**Problem 1.36:** A mountain climber with mass  $m = 75$  kg is rappelling down a vertical wall as shown. The 3.0-m long rope attaches to a buckle strapped to the climber's waist 15 cm to the right of the center of gravity, which is 90 cm away from the wall.

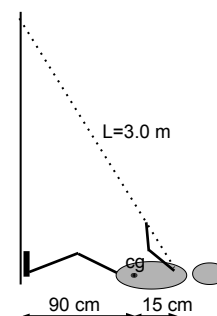

- Draw the free-body diagram for the climber.
- Write down Newton's second law for the person.
- Make your choice for the axis of rotation and calculate the torque about that axis.
- Find the tension in the rope and the friction force between shoes and the rock.
- Rain reduces the friction between rock and the climber's boots. If the coefficient of static friction is  $\mu_s = 0.63$ , what is the *shortest* rope that the climber can use so that she does not slip?

**Problem 1.37:** During a *somersault*, a woman "tucks" her legs and arms, thereby decreasing her moment of inertia. The moment of inertia during the three phases are: lift-off  $I_1 = 14.6$  kg m<sup>2</sup>, highest point  $I_2 = 6.9$  kg m<sup>2</sup>, and landing  $I_3 = 12.5$  kg m<sup>2</sup>.

- The woman jumps off [phase 1] such that she rotates with the period  $T = 2.2$  s. Calculate the magnitude of her angular momentum and her rotational kinetic energy.
- Find the period of rotation when she is at the highest point [phase 2]!
- Calculate the work done by the muscles as she tucks her legs from phase 1 to phase 2.

**Problem 1.38:** A projectile is launched straight up from top of a tower. The height of the tower is unknown. The rocket hits the ground after 14.4 s. We only consider the motion along the vertical, and use a coordinate system with  $+y$  directed upwards. The average velocity is  $v_{\text{ave}} = -6.8 \text{ m/s}$ , and the average speed is  $31.2 \text{ m/s}$ .

- Find the height of the tower.
- Find the launch speed of the projectile.

**Problem 1.39:** Two blocks with masses  $m_1 = 0.7 \text{ kg}$  and  $m_2 = 0.9 \text{ kg}$  sit on frictionless inclined surfaces. The angles are  $\theta_1 = 44^\circ$  and  $\theta_2 = 10^\circ$ , respectively. The two blocks are connected by a rope that is wrapped around a pulley with radius  $r = 2.3 \text{ cm}$  and moment of inertia  $I = 3.2 \times 10^{-4} \text{ kg m}^2$ .

- Draw the appropriate free-body diagram(s) for the problem.
- Write down Newton's second law for the two blocks and the pulley.
- Assume that the pulley rotates without slipping. Find the acceleration of the two blocks
- Find the tension(s) in the rope.

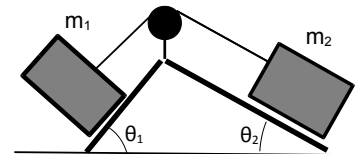

**Problem 1.40:** A wooden plank with mass  $m = 7.2 \text{ kg}$  and length  $L = 5.2 \text{ m}$  is dragged with a rope on one end of the plank. The plank moves with a constant speed  $v_0 = 0.6 \text{ m/s}$  and the angle  $\theta = 41^\circ$  with the surface is kept constant. The coefficient of *kinetic* friction between the plank and the surface is  $\mu_k = 0.63$ .

- Draw the free body-diagram for the plank!
- Write down Newton's second law for the plank!
- Choose an axis of rotation and write down the equation for the torque about that axis.
- Find the magnitude and the direction of the tension in the rope.

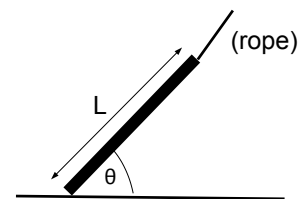

**Problem 1.41:** A block with mass  $m = 4.2 \text{ kg}$  sits *at the center* of a 1.4-m long board that is supported by two springs on the left and right side. We ignore the mass of the board; the constants of the two springs are not known.

- The springs are compressed unequally: the spring on the left is compressed  $y_l = 4.2 \text{ cm}$  from the unstretched length, while the spring on the right is compressed only  $y_r = 2.5 \text{ cm}$ . Find the constants of the two springs. (*Ignore the slight tilt of the board.*)
- We now move the block along the board such that the two springs are compressed equally. Find the new position of the 4.2-kg block.

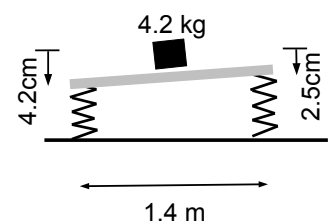

**Problem 1.42:** In a diving event, the platform is 10 m above the water surface (i.e., pool). The athlete (with mass  $m = 56$  kg) runs on the platform with a speed of 4.5 m/s. Assume that the person can be considered a point mass.

- Find the total mechanical energy of the athlete! Choose  $y = 0$  at the water surface.
- The athlete jumps off an elastic board and leaps in vertical direction. What is the maximum height does she reach?
- The diver turns around and falls towards the water. She then plunges into the water and dives to a depth  $d = 1.75$  m below the water surface until she turns around. What is the work done on the diver by the the water?
- Find the magnitude and direction of the average force exerted by the water on the diver.

**Problem 1.43:** A block with mass  $m = 0.75$  kg sits on a frictionless, horizontal table and is attached to a spring with unknown constant  $k$ . The coordinate of the block is recorded as a function of time,  $x = x(t)$ .

- Estimate the average velocity and average speed between times  $t = 0$  and  $t = 2.4$  s?
- Estimate the maximum instantaneous velocity of the block during the time interval  $0 < t < 2.4$  s? Estimate the time when the block travels at the maximum velocity?
- What is the spring constant  $k$ ?

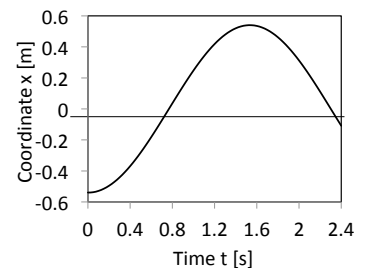
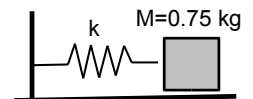

**Nido**

**Luxurious accommodation**

**Central zone 1 & 2 locations**

**Meet hundreds of international students**

**BOOK NOW and get a £100 voucher from voucherexpress**

**Nido Student Living - London**

**Visit [www.NidoStudentLiving.com/Bookboon](http://www.NidoStudentLiving.com/Bookboon) for more info.**

**+44 (0)20 3102 1060**



**Problem 1.44:** A wooden board of length  $L = 1.20$  m and mass  $M = 3.4$  kg is supported by one leg at the distance  $d = 0.85$  m from the left end of the board and a cable anchored to the floor at 1.9 m from the left end of the board. The length of the leg is 1.4 m.

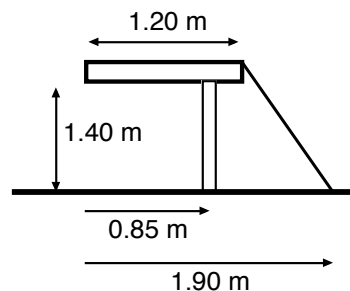

- Draw the free-body diagram for the problem.
- Write down Newton's second law for the board.
- Choose an axis of rotation and find the torque about it.
- Find the tension in the cable.
- What is the magnitude of the force exerted by the leg on the board?

**Problem 1.45:** Two masses with  $m = 0.45$  kg are placed at the end of a stick that is placed on a massless rotor. The length of the stick is  $2R = 0.6$  m and the rotor has a radius  $r = 0.05$  m.

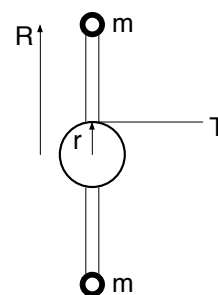

- Calculate the moment of inertia of the system.
- You pull with an unknown constant force on the cord that is wrapped around the rotor. The rotor is initially at rest. You pull for the time  $t = 0.64$  s, and the cord is pulled the distance  $s = 8.6$  cm. Find the angular acceleration of the rotor!
- How 'hard' do you pull on the cord? That is, find the tension in the cord!

**Problem 1.46:** Emmy starts at time  $t = 0$  and drives along a straight path: she starts at a point A, drives straight to the point B, turns around and drives to point C. She finishes in a time  $t = 14.7$  s. Her average speed is 17.0 m/s, and the magnitude of the average velocity is 9.3 m/s.

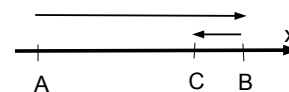

- Find distances between points A and B and points B and C.
- Emmy drives twice as fast from A to B than she drives from B to C. Find her respective speeds.

**Problem 1.47:** You observe the Fourth of July celebration from the 47th floor of a skyscraper. Revellers shoot fireworks from a river. A projectile passes your window at time  $t = 0$  s, reaches the peak at time  $t_1 = 2.1$  s, and then falls back into the river at the time  $t_2 = 11.8$  s. Treat the flight of the projectile as free fall along the vertical.

- What is the speed of the projectile as it passes by your window?
- What is the height of your window above the river?

**Problem 1.48:** A #2 pencil has mass  $M = 0.008$  kg (assume homogeneous mass distribution) and length  $L = 0.16$  m. The moment of inertia about the tip is  $I = ML^2/3 = 6.8 \times 10^{-5}$  kg m<sup>2</sup>.

- a) The pencil is initially in upright position with zero speed. What is the total mechanical energy of the pencil?  
 b) Assume that the tip does not slip on the table surface. Find the angular speed of the pencil when it has rotated 30 degrees away from the vertical.

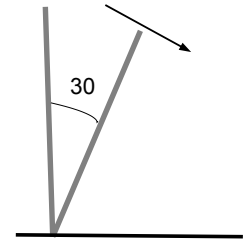

**Problem 1.49:** Harry is a street artist who juggles balls. He has a different ball in his hand every 0.35 seconds. Ignore the (short) time the balls are in his hands and the (small) *up-and-down* motion of the hands. Assume that the trajectory of each ball is along the vertical only.

- a) Harry juggles a *red* and *green* ball. At the instant when the *red* ball is in his hand, what is the height of the *green* ball?  
 b) Find the speed of the balls when they leave Harry's hand.  
 c) Harry now juggles a *red*, *green*, and a *blue* ball. What is the *maximum* height that the balls reach?  
 d) Calculate the (vertical) positions of the *green* and *blue* ball at the instant when the *red* ball is in Harry's hands.

**Problem 1.50:** An unknown weight  $W$  is suspended from two ropes at fixed angles  $\theta_1 = 52^\circ$  and  $\theta_2 = 22^\circ$ . The tension in one rope is known  $T_1 = 28$  N, but the tension in the other rope  $T_2$  is not known. The weight is always directed along the vertical (or *plumb-line*).

- a) Find the vertical and horizontal components of the tension  $\vec{T}_1$ !  
 b) Find the magnitude of the tension  $T_2$  and the weight  $W$ .  
 c) The weight  $W$  is increased by 12.0 N. What are the tensions  $T'_1$  and  $T'_2$  in the two ropes? (The angles are kept fixed.)

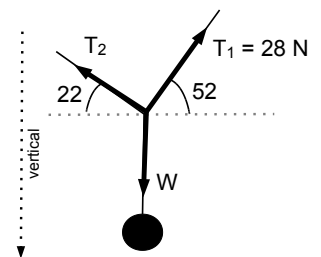

**Problem 1.51:** A bob with mass  $m = 0.7$  kg is attached to a string with length  $l = 0.91$  m that is secured to the ceiling on the other end.

- The bob is released from rest at an unknown angle  $\phi_0$  from the vertical.  
 a) When the bob passes through on the vertical, the tension in the rope is  $T = 11.3$  N. Find the speed  $v$  of the bob at that instant.  
 b) Find the average net force acting the bob as it swing from the angle  $\phi = \phi_0$  to the vertical position  $\phi = 0$ .

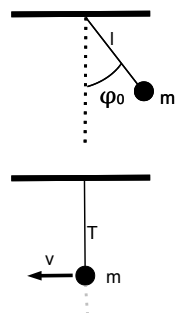

**Problem 1.52:** You are helping your school-age cousin to win the annual *egg drop* competition at her elementary school. The eggs are dropped from the height  $h = 4.7$  m. The goal is to protect the egg with packaging such that it survives the impact with the ground. The mass of a typical large chicken egg is  $m = 57$  g.

- Find the momentum of the egg right before it hits the ground.
- You estimate that it takes about  $\Delta t = 0.020$  s for the egg to come to a full stop. What (average) force [*magnitude and direction!*] does the ground exert on the egg while it comes to a full stop?
- How thick must the foam be for the egg to ‘survive’ the fall?

**Problem 1.53:** A block with mass 2.3 kg sits on a frictionless table and is attached by a string to a block with mass 1.7 kg. At time  $t = 0$ , the the bocks are released from rest.

- What is the speed of the blocks when the 1.7-kg block has fallen the distance  $d = 0.31$  m along the vertical.
- Identify the forces acting on the 2.3-kg block; determine the work done on the 2.3-kg block by all forces.
- Identify the forces acting on the 1.7-kg block; determine the work done on the 1.7-kg block by all forces.
- Find the tension in the string connecting the two blocks.

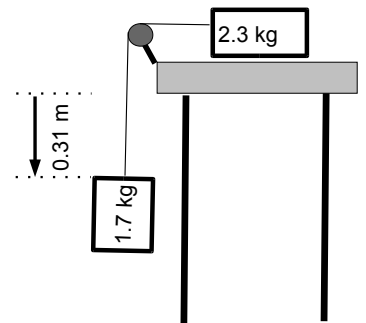

**Brain power**

By 2020, wind could provide one-tenth of our planet's electricity needs. Already today, SKF's innovative know-how is crucial to running a large proportion of the world's wind turbines.

Up to 25 % of the generating costs relate to maintenance. These can be reduced dramatically thanks to our systems for on-line condition monitoring and automatic lubrication. We help make it more economical to create cleaner, cheaper energy out of thin air.

By sharing our experience, expertise, and creativity, industries can boost performance beyond expectations. Therefore we need the best employees who can meet this challenge!

The Power of Knowledge Engineering

Plug into The Power of Knowledge Engineering.  
Visit us at [www.skf.com/knowledge](http://www.skf.com/knowledge)

**SKF**

 Click on the ad to read more

**Problem 1.54:** A spool with mass  $m = 2.3 \text{ kg}$  and moment of inertia  $I = 5.4 \times 10^{-3} \text{ kg m}^2$  sits on a horizontal surface. The coefficient of static friction between spool and the surface is  $\mu_s = 0.13$ . The radius of the spool is  $R = 0.06 \text{ m}$ .

- A force  $F$  acts on the axle (center). Draw the appropriate free-body diagram(s) and write down the corresponding Newton's second law(s).
- What is the maximum force  $F$  so that the spool rolls *without slipping*? What is the corresponding linear acceleration of the spool along the surface?
- We now use another spool with the same mass  $m$ , moment of inertia  $I$ , and outer radius  $R$  but with an inner drum of radius  $r = 0.048 \text{ m}$ . We apply the external force  $F'$  at the inner drum. Draw the appropriate free-body diagram(s) and write down the corresponding Newton's second law(s).
- What is the maximum force  $F'$  so that the spool rolls *without slipping*? What is the corresponding linear acceleration of the spool along the surface?

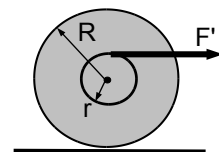
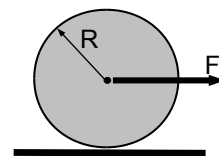

**Problem 1.55:** A block with mass  $m = 1.5 \text{ kg}$  sits on a smooth table [i.e., there is no friction] and is attached to a spring with constant  $k$ .

- The block undergoes oscillatory motion with period  $T = 1.2 \text{ s}$ . If the oscillatory motion has amplitude  $A = 0.15 \text{ m}$  find the speed of the block as it passes through the equilibrium position.
- A piece of clay with unknown mass  $M$  falls on the block at the instant when the block passes through the equilibrium point. Subsequently, the two blocks now undergo oscillatory motion with period  $T' = 1.4 \text{ s}$ . Find the mass  $M$  of the piece of clay!
- What is the amplitude of the oscillation of the block with the piece of clay move together?

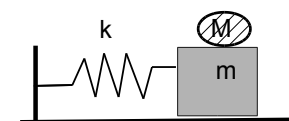
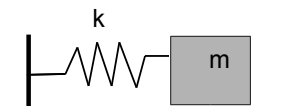

**Problem 1.56:** A 14-kg box with height  $H = 12 \text{ cm}$  and length  $L = 26 \text{ cm}$  sits on an incline plane  $\theta = 17^\circ$ . The front leg is rough and the back leg is polished so that there is friction acting on the front leg only. The coefficient of static friction is  $\mu_s = 0.7$ .

- Draw the free body-diagram!
- Write down Newton's second law for the problem. Choose an axis of rotation and write down the torque about that axis.
- Find the forces acting on the box.
- Find the angle  $\theta_{\text{max}}$  when the box begins to slide. Use  $\cos(\alpha + \beta) = \cos \alpha \cos \beta - \sin \alpha \sin \beta$ .

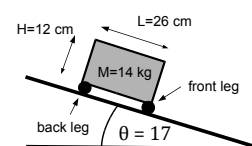



**Problem 1.57:** A Yo-Yo is a uniform disk with mass  $m = 0.24$  kg, outer radius  $R = 0.12$  m, and inner radius  $r = 0.08$  m. A string hangs from the ceiling and is wrapped around the inner ring. Assume that the string is along the vertical. The Yo-Yo starts from rest and the falls due to its own weight. After the Yo-Yo falls through the height  $h = 0.20$  m, it travels with the speed  $v = 0.6$  m/s.

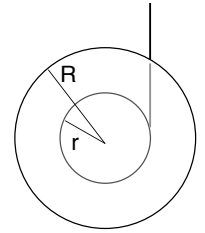

- Find the constant angular acceleration.
- Find the moment of inertia of the Yo-Yo.
- Find the tension in the string.

**Problem 1.58:** In Lewis Carroll's novel *Alice in Wonderland*, the fictional case of free fall inside a tunnel through the center of the Earth is described. An object is released from rest at the surface of the Earth, and then undergoes *simple harmonic motion* (SHM). The maximum acceleration of the object is "gravity"  $|a_{\max}| = g = 9.8$  m/s<sup>2</sup>. Use  $R_E = 6.38 \times 10^6$  m for the radius of the Earth, and ignore the rotation of the Earth.

- At time  $t = 0$  the object is released from the the surface of the Earth, where its acceleration is  $g = 9.8$  m/s<sup>2</sup>. When does the object reappear on the other side of the Earth?
- What is the speed of the object when it passes through the center of the Earth?
- A satellite is put on a near-Earth orbit so that  $r = R_E$ . How long does it take for the satellite to travel to the other side of the Earth? Compare your result to answer in part a)!

**Problem 1.59:** A bullet of mass  $m = 0.023$  kg and unknown speed  $V$  buries itself in a block with mass  $M = 0.8$  kg that is initially at rest. The block sits at the bottom of a ramp with angle  $\theta = 28^\circ$ . Ignore friction force between the block and the incline.

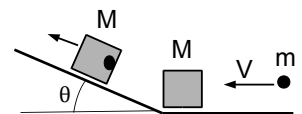

- The block with the bullet buried inside travels up the incline during the time interval  $\Delta t = 4.2$  s until it comes to a momentary stop. Find the impulse (*vector!*) of the net force acting on the block!
- Find the initial velocity of the block when it starts to move up the incline.
- What is the speed of bullet?
- What fraction of the initial total energy is dissipated when the bullet buries itself into the block?

**Problem 1.60:** A block of mass  $m_1 = 1.75$  kg is attached to a cord of length  $L_1 = 1.6$  m to the second block of mass  $m_2 = 0.6$  kg. The blocks move in horizontal circles on a frictionless table. The second block is attached to a cord of length  $L_2 = 0.4$  m attached to the center of rotation.

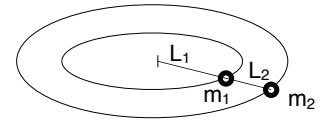

- Draw the free-body diagrams for the two blocks, and write down Newton's second law for the blocks.
- The two blocks are spun faster and faster until the string connecting the two blocks tears when it reaches the tension  $T_{\max} = 74$  N. Find the period of the spinning blocks at the instant when the string connecting the two blocks breaks.
- Find the tension in the cord connecting the mass  $m_1$  to the center when the short cord breaks.

**Problem 1.61:** A uniform box with mass  $m = 15.3$  kg has height  $h = 3.2$  m and width  $w = 0.73$  m. The box sits on the bed of a truck.

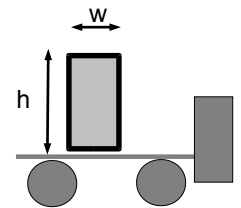

- What is the maximum acceleration of the truck so that the box does not “topple?”
- What is the minimum coefficient of static friction so that the box also does not slide at the maximum acceleration?

## GET A MASTER'S DEGREE IN UMEÅ!

- modern campus • world class research • 32 000 students
- top class teachers • ranked nr 1 in Sweden by international students

**Master's programmes:**

- Architecture
- Industrial Design
- Science
- Engineering

Download  
brochure  
here!

UMEÅ UNIVERSITY

FACULTY OF SCIENCE & TECHNOLOGY



**Problem 1.62:** Satellite used for the transmission of telecommunications are *stationary*, i.e., they keep the same location in the sky, relative to the Earth.

- How high above the surface of the Earth surface is the satellite? Express the result in relation to the Earth radius  $R_E = 6380$  km.
- How many times does the satellite passes over the same spot?

**Problem 1.63:** The *Monster Water Cannon* shoots water to a maximum height  $H_{\max} = 30.5$  m [100 feet] up in air. Harry [mass  $m_H = 45$  kg] mounts a 4-gal tank filled with water [mass  $m_W = 15.05$  kg] on a cart [mass  $m_{\text{cart}} = 8.4$  kg], and shoots water with the cannon. We ignore friction forces.

- He squirts the water along the horizontal. Each time, he squirts 12-oz of water [with mass 0.35 kg]. What is Harry's speed after he squirts the gun once?
- What is Harry's speed after he squirts the gun twice?
- Harry squirts at the rate of 12 times per minute. What is Harry's speed after he completely empties the 4-gal of water in the tank?
- What is the (average) power generated by the "water-gun engine?"

**Problem 1.64:** Colby stands on top of a tower with height  $H = 7.3$  m and throws a ball horizontally with unknown speed  $v_0$ . A vertical wall with height  $h = 5.9$  m is at the distance  $d = 2.5$  m in front of the tower. Ignore Colby's height so that the ball leaves at an initial height 7.3 m.

- What is the minimum launch speed so that the ball clears the wall?
- What is the shortest distance behind the wall where the ball can hit the ground?

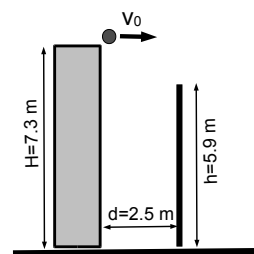

**Problem 1.65:** A wheel with mass  $M = 5.4$  kg, moment of inertia  $I = 0.014$  kg m<sup>2</sup>, and radius  $R = 6.0$  cm sits on a table. The axis of the wheel is connected by a string to a hanging mass  $m = 4.3$  kg. The wheel rolls *without slipping*. The block and the wheel are initially at rest, with the block at the height  $h = 24$  m above the ground.

- Find the speed of the hanging block when it hits the ground.
- Find the (constant) torque acting on the wheel.

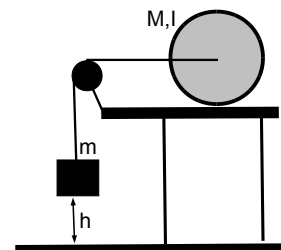

**Problem 1.66:** Colby is a physics student who is terrible at collecting all data in her physics lab. In the lab, she examine the collisions of gliders on an air track. The masses of the gliders are  $m_1 = 0.434$  kg and  $m_2 = 0.366$  kg. Her data for the velocities of the two gliders before and after the collision are *incomplete*:

$v_{1i}$ [m/s]	$v_{2i}$ [m/s]	$v_{1f}$ [m/s]	$v_{2f}$ [m/s]
1.20		-0.40	1.26

- Calculate the total kinetic energy and the total momentum *after* the collision.
- What is the impulse (*vector*) imparted on the glider with mass  $m_2$  during the collision?
- Find the velocity of the glider with mass  $m_2$  *before* the collision.
- Is the collision completely elastic?

**Problem 1.67:** A  $m_1 = 2.1$  kg block sits on an incline plane with angle  $\theta = 35^\circ$ . The coefficients of static and kinetic friction between the block and the plane are not known. The block is attached to a rope, which is hung over a pulley and attached to a hanging mass  $m_2$ .

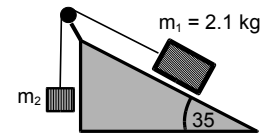

a) Draw the appropriate free-body diagram(s) and write down Newton's second law(s).

b) The block  $m_1$  is *on the verge of sliding*, when the hanging mass is increased to  $m_2 = 1.6$  kg. Find the coefficient of static friction!

c) An identical block [with mass  $m_1$ ] is placed on top of the block on the incline plane. The hanging mass  $m_2$  is left unchanged. The two blocks on the incline plane are sliding *down* the incline. Draw the appropriate free-body diagrams and write down Newton's second law.

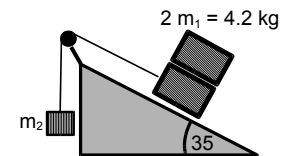

d) The blocks on the incline slide down with acceleration  $a = 0.31$  m/s<sup>2</sup>. Find the coefficient of kinetic friction.



Scholarships



**Ln.u.se**

## Open your mind to new opportunities

With 31,000 students, Linnaeus University is one of the larger universities in Sweden. We are a modern university, known for our strong international profile. Every year more than 1,600 international students from all over the world choose to enjoy the friendly atmosphere and active student life at Linnaeus University. Welcome to join us!

## Linnaeus University

Sweden

**Bachelor programmes in**  
*Business & Economics | Computer Science/IT | Design | Mathematics*

**Master programmes in**  
*Business & Economics | Behavioural Sciences | Computer Science/IT | Cultural Studies & Social Sciences | Design | Mathematics | Natural Sciences | Technology & Engineering*

**Summer Academy courses**



**Problem 1.68:** Two blocks with masses  $m_1$  and  $m_2$  are connected to identical strings with length  $l = 0.86$  m. The mass of the lower block is  $m_2 = 0.25$  kg. The mass  $m_1$  of the upper block is *unknown*. We swing the blocks so that the two blocks undergo uniform circular motion in horizontal planes.

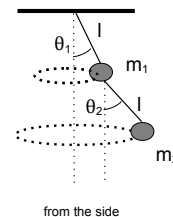

- Draw the appropriate free-body diagram(s) and write down appropriate Newton's second law(s).
- When the two blocks are swung such that two the strings are at angles  $\theta_1 = 24^\circ$  and  $\theta_2 = 35^\circ$ , respectively. Find the tension in the string connecting the two blocks.
- Find the period of the uniform circular motion.
- Find the mass  $m_1$  and the tension in the string connecting  $m_1$  to the ceiling.

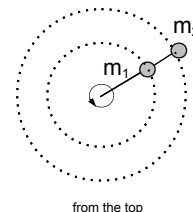

**Problem 1.69:** In Steve Haake's book "The Physics of Golf" [Science Spectra, Number 13 (1997)], the force on a golf ball by the club is estimated at 2,000 lbs, or 9 kN. The mass of the ball is 45.9 grams and the diameter is about 4.3 cm.

- Make reasonable assumption(s) and discuss whether the force is reasonable.
- Calculate how long the club is contact with the ball.
- How much the ball is distorted?

**Problem 1.70:** A ball is launched off the ground at  $(x = 0, y = 0)$  at the time  $t = 0$ . At the time  $t_1 = 0.34$  s, the position is  $(x = 1.2$  m,  $y = 0.45$  m).

- What is the launch speed and launch angle of the ball?
- Find the location of the ball at  $t_2 = 0.53$  s.
- Find the coordinates  $(x_p, y_p)$  at the "peak" of the trajectory.

## 2: FLUIDS AND THERMAL SYSTEMS

**Problem 2.1:** Apples consist (mostly) of cellulose (“fiber”) and water. We cut 62-grams of apple into small slices, wrap them into aluminum foil, and put them in an icebox at temperature  $0^\circ\text{C}$ . We fill a calorimeter with 0.117 liter of water at  $51^\circ\text{C}$ . The specific heat of the calorimeter can be ignored. The specific heat of cellulose  $c_{\text{cellulose}} = 1400 \text{ J}/(\text{kg}\cdot^\circ\text{C})$ . Useful data: for water ( $\text{H}_2\text{O}$ )

Property	Value
Latent heat: Vaporization	$22.6 \times 10^5 \text{ J/kg}$
Latent heat: Fusion	$33.5 \times 10^4 \text{ J/kg}$
Specific heat: ice	$900 \text{ J}/(\text{kg}\cdot^\circ\text{C})$
Specific heat: water	$4186 \text{ J}/(\text{kg}\cdot^\circ\text{C})$
Density: ice	$917 \text{ kg/m}^3$
Density: water	$1000 \text{ kg/m}^3$

- The chilled apple slices are put into the calorimeter. The temperature of the water drops to  $35^\circ\text{C}$ . What is the average specific heat of apples?
- What is the (mass) fraction of water in apples?

**Problem 2.2:** A cylinder with cross-section  $A = 0.01 \text{ m}^2$  and total height 14 cm is filled with diatomic gas at temperature  $T_0 = 300 \text{ K}$ . The cylinder is thermally insulated from the outside. A frictionless piston separates the cylinder into two equal parts as shown. The piston conducts heat so that the two compartments are always in *thermal* equilibrium. The initial pressure in each compartment is  $P_0 = 1.0 \times 10^5 \text{ Pa}$ . We ignore the mass of the hanger.

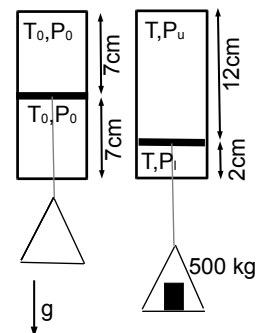

- A block with mass 500 kg is put on the hanger so that it moves 5.0-cm downward until it comes to rest. and the temperature of the gas rises. What is the (common) temperature  $T$  of the gas inside the cylinder?
- What are the pressures  $P_u$  and  $P_l$  in the upper and lower compartments of the cylinder?
- Find the pressure difference between the upper and lower compartments of the cylinder.

**Problem 2.3:** A quarter (the *25-cent coin*) has a diameter of 24.3 mm and a thickness of 1.75 mm and sinks inside a 1.5 m-high glass column filled with water. Ignore drag forces that depend on the orientation of the quarter.

- Find the buoyant force when the quarter is submerged in water.
- The coin is dropped at zero initial speed. It reaches the bottom in a time  $t = 0.60 \text{ s}$ . Find the acceleration of the quarter.
- Find the (average) density of the quarter.

**Problem 2.4:** Your ingenious nephew figures that if he were able to float the top of a flexible snorkel out of the water, he would be able to breathe through it while walking under water. Use  $\rho = 1,000 \text{ kg/m}^3$  for the density of water.

- Outside the water, suppose your nephew can just breathe while lying on the floor with a 400-N weight [about 80 lbs] on his chest. His chest has a frontal area of  $A = 0.09 \text{ m}^2$ . What is the maximum pressure that his lungs can generate while they inflate?
- How far below the surface of the water could his chest still be and he is still able to breathe? *What do you tell your nephew?*

**Problem 2.5:** The pressure of water in a section of a horizontal pipe with diameter of  $d = 2.0 \text{ cm}$  is 142 kPa. Assume that water is incompressible and has the density  $\rho = 1.0 \times 10^3 \text{ kg/m}^3$ .

- It takes 4.2 seconds to fill a 16-L [ $16 \times 10^{-3} \text{ m}^3$ ] bucket with water. Calculate the speed of the water in the pipe.
- A section of the pipe is constricted to  $d' = 1.6 \text{ cm}$ . How fast does the water flow in the constricted section? Water is incompressible, i.e., the density is uniform in the entire pipe.
- What is the water pressure in the constricted section of the pipe?

**Problem 2.6:** Water rises up to a height  $h = 3.7 \text{ cm}$  inside a glass pipette with diameter  $d = 4.0 \text{ mm}$ . The air above the water surface is not moving and the air pressure is  $P_0 = 1.01 \times 10^5 \text{ Pa}$ .

Use  $\rho_w = 1000 \text{ kg/m}^3$  and  $\rho_{\text{air}} = 1.29 \text{ kg/m}^3$  for the density of water and air, respectively. The wind is the source of the pressure difference.

- Find the difference  $\Delta P = P - P_0$  between the pressure inside the pipette and above the water surface.
- The pressure difference is produced by blowing air over the pipette. Find the speed of the air.

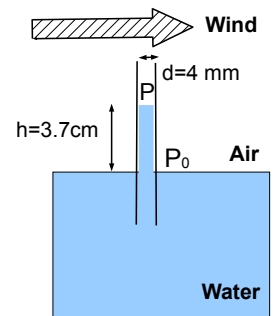

**Problem 2.7:** A wooden block with dimensions  $52 \text{ cm} \times 63 \text{ cm} \times 17 \text{ cm}$  floats on water such that 4.0-cm sticks out of the water. Use  $\rho_w = 1000 \text{ kg/m}^3$  for the density of water.

- What is the density of the wood?
- What force do you have to exert on the block so that only 3.0-cm sticks out of the water?
- What (mechanical) work is necessary to completely “dunk” the wooden block?

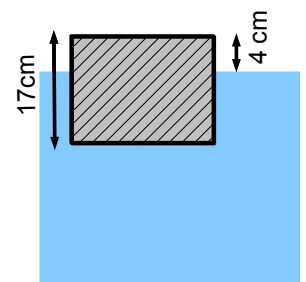

**Problem 2.8:** Steam (gaseous  $\text{H}_2\text{O}$ ) at the pressure  $P = 15.8 \text{ atm} = 15.8 \times 10^5 \text{ Pa}$  and temperature  $T = 312^\circ\text{C}$  is inside a thermally insulated 2-liter container.  
Useful data: molar mass of water  $M = 18 \text{ g/mol}$  and density of water  $\rho = 1,000 \text{ kg/m}^3$ .

Phase	Specific heat [J/(kg°C)]
ice	2,000
water	4,186
steam	1,800

Transformation	Latent Heat [J/kg]
Fusion	$33.5 \times 10^4$
Vaporization	$22.6 \times 10^5$

- a) Find the mass of the steam inside the container.  
b) A cup with 150 ml water at temperature  $T = 8^\circ\text{C}$  is placed inside the container. Assume that no steam escapes from the container and that all steam condenses, i.e., turns to water. Find the final temperature of the water inside the cup!

**Problem 2.9:** A balloon with volume  $V = 6.7 \text{ L}$  is filled with oxygen  $\text{O}_2$ . Assume room temperature  $T = 25^\circ\text{C}$ . The molar mass of oxygen (O) is  $M = 16.0 \text{ g/mol}$ .

- a) What is the mass of oxygen necessary to inflate the balloon at atmospheric pressure?  
b) The balloon is submerged in a waterpool at a depth  $h = 5.8 \text{ m}$  below the water surface. What is the mass of the oxygen that you have to add to or remove from the balloon to maintain a constant volume? Assume that the water is at room temperature.



In the past four years we have drilled  
**89,000 km**  
That's more than **twice** around the world.

**Who are we?**  
We are the world's largest oilfield services company<sup>1</sup>.  
Working globally—often in remote and challenging locations—we invent, design, engineer, and apply technology to help our customers find and produce oil and gas safely.

**Who are we looking for?**  
Every year, we need thousands of graduates to begin dynamic careers in the following domains:

- Engineering, Research and Operations
- Geoscience and Petrotechnical
- Commercial and Business

**What will you be?**

[careers.slb.com](http://careers.slb.com)

**Schlumberger**

<sup>1</sup>Based on Fortune 500 ranking 2011. Copyright © 2015 Schlumberger. All rights reserved.





**Problem 2.10:** 1 British thermal unit, or “1 Btu,” is commonly used in specifications of major household appliances. It is defined as the energy needed to raise the temperature of one pound of water by  $1^\circ\text{F}$  [ $\frac{5}{9}^\circ\text{C}$ ]. Useful values: specific heat of water  $c = 4186 \text{ J}/(\text{kg } ^\circ\text{C})$ , specific heat of air  $c = 780 \text{ J}/(\text{kg } ^\circ\text{C})$ , and molar mass of air  $M = 29.0 \text{ g/mol}$ .

- How many Joules is equal to 1 Btu? Use  $1 \text{ lb} = 4.44 \text{ N}$
- Calculate the mass of air in your living room  $10.0 \text{ m} \times 6.0 \text{ m} \times 2.5 \text{ m}$ . The pressure is 1 atm [ $1.01 \times 10^5 \text{ Pa}$ ], and the temperature is  $T = 55^\circ\text{F}$  [or  $285 \text{ K}$ ].
- Calculate the heat in Btu’s to raise the temperature in the living room from  $55^\circ\text{F}$  [ $285 \text{ K}$ ] to a more comfortable  $65^\circ\text{F}$  [ $292 \text{ K}$ ].

**Problem 2.11:** You use a “space heater” to heat your living room on a cold winter day. The total mass of air in the living room is  $M = 400 \text{ kg}$ . The outside temperature is  $T_{\text{out}} = 0^\circ\text{C}$  [about  $30 \text{ F}$ ] and the inside is kept at a comfortable  $T_{\text{in}} = 25^\circ$  [about  $65 \text{ F}$ ]. Warm air escapes from the living room through “leaky” windows and is replaced by cold air from the outside. The specific heat of air is  $c = 780 \text{ J}/(\text{kg } ^\circ\text{C})$ . Treat the inside and outside temperatures as the reservoir temperatures for the heat pump.

- The electric power of the space heater is  $1500 \text{ W}$ . What is the fraction of warm air that is replaced by cold air every minute?
- What electric power is required to heat your living room, if you install a heat pump?

**Problem 2.12:** A plastic buoy has mass  $m = 1.75 \text{ kg}$  and has a volume  $V = 5.4 \text{ liters}$ . The buoy is tied to a string and held completely under water. Use  $\rho = 1.0 \times 10^3 \text{ kg/m}^3$  for the density of water.

- Write down Newton’s second law for the buoy.
- Find the tension in the string.
- The string rips during a storm. What is the volume fraction of the buoy submerged under water when it floats on the surface.

**Problem 2.13:** A hot air balloon has the constant volume  $V = 623 \text{ m}^3$ .

The balloon is open at the bottom so that air can enter/leave from the ambient air. The pressure is  $P_0 = 1.01 \times 10^5 \text{ Pa}$  everywhere. The temperature of the ambient air is  $T_{\text{amb}} = 20^\circ\text{C}$ . The insulating layer allows that the temperature inside the balloon is different from that of the ambient air. Use  $M = 28.9 \text{ g/mol}$  for the molar mass of (dry) air.

- How many moles of air molecules are inside the balloon when the temperature is  $T_0 = 20^\circ$ ? The temperature is increased to  $T_1 = 62^\circ\text{C}$ . How many moles of air molecules are expelled in the process?
- A load of mass  $m = 74 \text{ kg}$  is now attached to the hot air balloon. The hot air balloon is released from ground at time  $t = 0$ . At what time does the balloon reach the top of a  $216\text{-m}$  tall tower? Ignore the mass of the insulating layer.

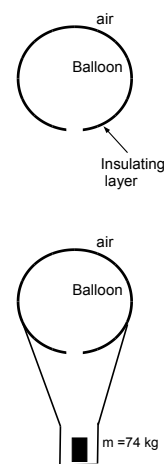

**Problem 2.14:** The compartments on the left and right side contain air and are separated by a wall covered with an insulating layer. The two pistons maintain constant pressures on the left and right sides  $P_1 = P_2 = 1 \text{ atm} = 1.01 \times 10^5 \text{ Pa}$ . The volume and temperatures on the left side are  $V_1 = 4.3 \text{ liter}$  and  $T_1 = 40^\circ\text{C}$ , and those on the right side are  $V_2 = 5.7 \text{ liter}$  and  $T_2 = 92^\circ\text{C}$ . The cross-sectional area of the piston is  $A = 1.2 \times 10^{-2} \text{ m}^2$ .

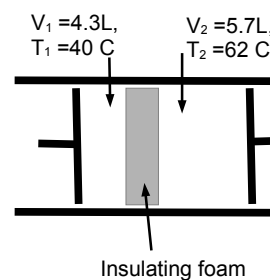

- The insulating layer of the wall is removed and thermal equilibrium is established. What is the common temperature of the two compartments?
- The wall is now free to move. How much does the wall move?

**Problem 2.15:** A rectangular block of ice with cross-section  $A = 0.03 \text{ m}^2$  and unknown height  $h$  sits on a horizontal surface. We examine the melting of this ice cube.

Useful data: specific heat of ice  $c_{\text{ice}} = 2150 \text{ J}/(\text{kg } ^\circ\text{C})$ , specific heat of water  $c_{\text{water}} = 4186 \text{ J}/(\text{kg } ^\circ\text{C})$ , latent heat of fusion  $L_{\text{fusion}} = 33.5 \times 10^4 \text{ J}/\text{kg}$ , latent heat of vaporization  $L_{\text{vapor}} = 22.6 \times 10^5 \text{ J}/\text{kg}$ , density of ice  $\rho_{\text{ice}} = 917 \text{ kg}/\text{m}^3$ , density of water  $\rho_{\text{water}} = 1000 \text{ kg}/\text{m}^3$ , and density of vapor  $\rho_{\text{vapor}} = 1.29 \text{ kg}/\text{m}^3$

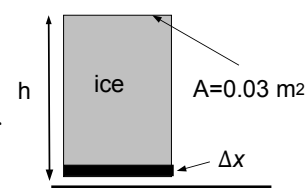

- Calculate the heat necessary to melt a small layer of thickness  $\Delta x = 1.0 \text{ cm}$  at the bottom of the ice block.
- The block of ice melts “under its own weight.” Find the maximum height so that the block does *not* melt.

**Problem 2.16:** In industrial production forced circulation of ambient air is used to cool down liquids during manufacturing processes. Useful data: specific heat of water  $c_w = 4186 \text{ J}/(\text{kg } ^\circ\text{C})$ , specific heat of air  $c_{\text{air}} = 1000 \text{ J}/(\text{kg } ^\circ\text{C})$ ; molar mass of air  $M_{\text{air}} = 29.0 \text{ g}$ .

- What mass of air at ambient temperature  $T_{\text{air}} = 20^\circ\text{C}$  must be used to cool 1.7-kg of water at  $80^\circ\text{C}$  to  $35^\circ\text{C}$ .
- Assume that ambient air is at the pressure  $P = 3.8 \text{ atm}$ . Find the volume of air that has to be used.

**Problem 2.17:** A rectangular block with cross-sectional area  $A = 0.32 \text{ m}$  and  $h = 1.22 \text{ m}$  floats on a lake. The (average) density of the block is not known. When the block floats on water, it is submerged. You push the boat down such that the boat is submerged an additional 1.3 cm. You let the boat go and the boat moves up-and-down with a period  $T = 5.8 \text{ s}$ .

- Explain why the boat undergoes simple harmonic motion.
- Find the approximate value of (average) density of the block.
- Find the fastest speed of block in vertical direction.

**Problem 2.18:** A model airplane has mass  $m = 1.5\text{ kg}$  and wing area  $A = 0.2\text{ m}^2$ . The plane is kept afloat by air streaming passed its wings. Ignore buoyancy due to the air. Use  $\rho = 1.29\text{ kg/m}^3$  for the density of air.

- Calculate the pressure difference between upper and lower surface.
- The wings are designed such that air rushes across the upper surface at twice the speed than it rushes across the lower surface. Find the speed of air flow over the upper surface so that the airplane does not fall to the ground.

**Problem 2.19:** The tires of a car (weight 2000 lbs, or 8889 N) are inflated to a gauge pressure of 32 psi, or  $2.21 \times 10^5\text{ Pa}$ . The tires have an outer radius of 34 cm and are 12 cm wide. What fraction of the tire tread is in contact with the surface?

## Trust and responsibility

NNE and Pharmaplan have joined forces to create NNE Pharmaplan, the world's leading engineering and consultancy company focused entirely on the pharma and biotech industries.

Inés Aréizaga Esteva (Spain), 25 years old  
Education: Chemical Engineer

– You have to be proactive and open-minded as a newcomer and make it clear to your colleagues what you are able to cope. The pharmaceutical field is new to me. But busy as they are, most of my colleagues find the time to teach me, and they also trust me. Even though it was a bit hard at first, I can feel over time that I am beginning to be taken seriously and that my contribution is appreciated.



NNE Pharmaplan is the world's leading engineering and consultancy company focused entirely on the pharma and biotech industries. We employ more than 1500 people worldwide and offer global reach and local knowledge along with our all-encompassing list of services.  
[nnepharmaplan.com](http://nnepharmaplan.com)

nne pharmaplan®



**Problem 2.20:** In a lab notebook you find the tabulated recording of the speed of Ne-atoms:

$v$ [m/s]	0 - 50	50 - 100	100 - 150	150 - 200	200 - 250	250 - 300
$N$	4	8	18	32	28	13

- a) Find the average speed  $\langle v \rangle$  and the root mean square speed  $v_{\text{rms}} = \sqrt{\langle v^2 \rangle}$  for this gas.  
 b) The molar mass of neon is  $M_{\text{Ne}} = 20.2$  g/mol. Find the temperature of the Ne-gas.

**Problem 2.21:** The density of air at room temperature is  $\rho_{\text{cold}} = 1.29$  kg/m<sup>3</sup> and at a higher temperature it is  $\rho_{\text{hot}} = 1.12$  kg/m<sup>3</sup>. A hot air balloon has a radius of  $R = 7.5$  m. The combined mass of the cabin and passenger is  $m_{\text{load}} = 212.1$  kg.

- a) Find the net force on the balloon!  
 b) A tower has height of 216 m. If the balloon starts near the ground, how long does it take to reach the top?

**Problem 2.22:** A student investigates a leaking bucket. The bucket has cross-sectional area  $A = 0.03$  m<sup>2</sup> and height  $h_0 = 0.26$  m. The student inserts a small pipe at the bottom. She fills the bucket to the rim and measures the height  $h$  of the water every half minute for 3 minutes:

Time [s]	0	30	60	90	120	150	180
Height [cm]	26.0	18.6	13.2	9.5	6.8	4.8	3.4

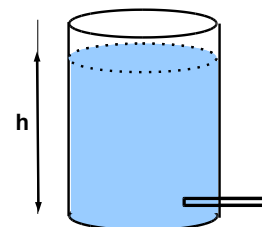

- a) Calculate the fractional change  $\Delta h/h$  for each time interval!  
 Is your result consistent with exponential time-dependence of the height of the water column? Find the time constant!  
 b) How long does Colby have wait until the bucket is nearly empty and the height of the water column is 5 mm?  
 c) The flow of water through a pipe is analogous to Ohm's law. The pressure  $\Delta P$  across the pipe corresponds to the voltage drop and the volume flow  $\Delta V/\Delta t$  corresponds to the current:

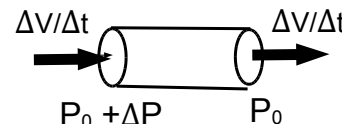

$$\Delta P = R \frac{\Delta V}{\Delta t}.$$

Find the resistance  $R$  of the pipe!

**Problem 2.23:** A ball with radius  $a = 1.1$  cm and density  $\rho_{\text{ball}} = 2560$  kg/m<sup>3</sup> is immersed in glycerol with density  $\rho_{\text{glycerol}} = 1412$  kg/m<sup>3</sup>. The friction force (“drag”) that a fluid exerts on a spherical object moving at moderate speeds  $v$  is given by Stokes' law:  $F_{\text{drag}} = 6\pi a\eta v$ , where  $\eta$  is the (*dynamic*) viscosity. The viscosity of glycerol is  $\eta = 1.412$  Pa·s. The ball is dropped in glycerol; after some time, the ball drops at a fixed speed (“terminal” speed)  $v_{\infty}$ .

- a) Find the terminal speed of the ball!  
 b) Show that the velocity exhibits exponential behavior  $v(t) = v_{\infty}[1 - \exp(-t/\tau)]$ .  
 c) Find the time constant  $\tau$  characterizing exponential behavior.

**Problem 2.24:** Air is 20% oxygen  $O_2$  and 80% nitrogen  $N_2$ . How much oxygen is inhaled into the lungs from air at a temperature of  $20^\circ\text{C}$  within 1 min in a relaxed state of respiration? The volume and frequency of inspiration are 0.5 L and  $15 \text{ min}^{-1}$ , respectively.

**Problem 2.25:** The interior of a home is at  $20^\circ\text{C}$ , and the roof cavity is at  $10^\circ\text{C}$ . Assuming a ceiling insulated to R2 ( $R = 2.0 \text{ m}^2 \text{ K/W}$ ), energy will be lost at a rate of  $10 \text{ K}/(2 \text{ m}^2 \text{ K/W}) = 5.0 \text{ W}$  for every square meter of ceiling. Find the power needed to heat the room with a space heater and a heat pump! Assume that the inside and outside temperatures are the temperatures of the heat reservoirs for the heat pump.

**Problem 2.26:** Assume that the working substance is four moles of an ideal, diatomic gas. We consider the process  $1 \rightarrow 2 \rightarrow 3 \rightarrow 1$  in the  $PV$ -diagram, as shown. The process  $2 \rightarrow 3$  is adiabatic.

- Calculate  $P$ ,  $V$ , and  $T$  for all three points.
- Sketch the process in the  $PT$ - and  $VT$ -diagrams.
- Calculate the work done *on the gas* for all three processes. What is the net work done *on the gas*?
- Calculate the heat added or removed for all three processes.
- What “type” of machine could the process  $1 \rightarrow 2 \rightarrow 3 \rightarrow 1$  represent?

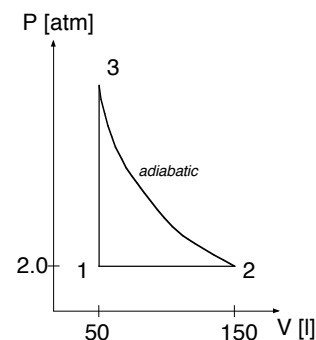

**Problem 2.27:** An ice cube from a typical freezer has a volume of approximately  $18 \text{ cm}^3$ . Suppose we slowly melt an ice cube at  $0^\circ\text{C}$ .

- What is the change in the entropy?
- What is the subsequent change in entropy when the water temperature is raised from  $0^\circ\text{C}$  is to  $1^\circ\text{C}$ .
- Which entropy change is larger, the change associated with melting or the change associated with a temperature increase of one degree Celsius? *Explain!*

**Problem 2.28:** The cycle  $A \rightarrow B \rightarrow C \rightarrow D \rightarrow A$  in the  $PT$ -diagram operates between the temperatures  $T_A = 300 \text{ K}$  and  $T_C = T_D = 650 \text{ K}$ . The pressure at  $A$  is  $P_A = 1.4 \text{ atm}$  and the temperature at  $B$  is  $T_B = 400 \text{ K}$ . The process  $A \rightarrow B$  is *isobaric*. Assume that the gas is *one mole of air*.

- Find the temperature, volume and pressure at the points  $A$ ,  $B$ ,  $C$ , and  $D$ .
- Draw the cycle in the  $PV$ -diagram. What type of “machinery” does the cycle represent?
- Calculate the heat added/removed and the work done on the gas for each ‘leg’ of the cycle.
- Calculate the efficiency/COP of the cycle.

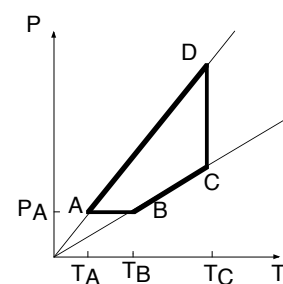

**Problem 2.29:** Two heat reservoirs are kept at temperatures  $T_c = 28^\circ\text{C}$  and  $T_h = 72^\circ\text{C}$ . Two heat conductors have the same cross-section  $A = 5.4 \times 10^{-4} \text{ m}^2$  and length  $L = 0.56 \text{ m}$ , but different thermal conductivities  $k_1 = 250 \text{ J}/(\text{s m}^\circ\text{C})$  and  $k_2 = 380 \text{ J}/(\text{s m}^\circ\text{C})$ .

- a) The heat reservoirs are connected by two conductors in parallel. Calculate the heat flow from the hot to the cold reservoir.
- b) The heat reservoirs are connected by two conductors in series. Calculate the heat flow from the hot to the cold reservoir.

a) Parallel

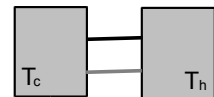

b) Series

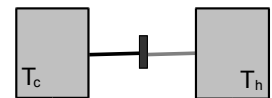

**Problem 2.30:** You use a hose with  $\frac{1}{2}$ -in diameter (1.27 cm) in your garden. It takes 25 seconds to fill a 4-gallon bucket (15.14 liter). Use  $\rho = 1,000 \text{ kg}/\text{m}^3$  for the density of water.

- a) What is the maximum range of the water stream (neglect the spread of the stream).
- b) You want to water the flower bed at the distance 8.0 m from the end of the hose. Calculate the part of the cross section of the hose that you need to leave uncovered by your thumb to water these flowers.
- c) Calculate the change in water pressure by partially covering the hose with your thumb.

This e-book  
is made with  
**SetaPDF**



PDF components for PHP developers

[www.setasign.com](http://www.setasign.com)



### 3: ELECTRICITY AND MAGNETISM

**Problem 3.1:** In a sodium molecule, the  $\text{Na}^+$  and  $\text{Cl}^-$  ions are separated by  $b = 0.23 \text{ nm}$  (assume that the ion charges are  $\pm e$ ). We choose a coordinate system such that the ions are at  $x = \pm b/2$ . An electron is placed at the distance  $r = 0.31 \text{ nm}$  and angle  $\theta = 63^\circ$  from the center.

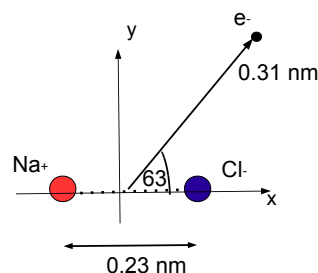

- Find the magnitude and direction of the force on the electron due to the  $\text{Na}^+$  and  $\text{Cl}^-$  ions.
- Find the magnitude and direction of the net force on the electron.

**Problem 3.2:** At time  $t = 0$ , the  $\text{He}^{2+}$ -ion is at the origin  $x = 0$  and is at rest  $v_{\text{He}} = 0$ ; the  $\text{H}^+$ -ion is at  $x = -5.1 \text{ nm}$  and has the velocity  $v_0 = 20,500 \text{ m/s}$ . Use  $m_{\text{He}} = 4 \text{ u}$  and  $m_{\text{H}} = 1 \text{ u}$  for the masses of the ions. We treat the interaction between the  $\text{He}^{2+}$ - and  $\text{H}^+$ -ions as a one-dimensional collision along the  $x$ -axis.

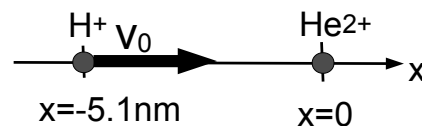

- Find the total energy of the system.
- Find the velocity of the center-of-mass of the system.
- Find the closest distance between the  $\text{He}^{2+}$ - and  $\text{H}^+$  ions during the collision.

**Problem 3.3:** A water molecule is shown. The angle between the OH-bonds is  $\theta = 106^\circ$  and the OH-distance is  $d = 9.42 \times 10^{-11} \text{ m}$ . The charges on the oxygen and hydrogen are “partial charges”  $q_{\text{O}} = -0.67e$  and  $q_{\text{H}} = 0.335e$ , respectively. An electron is placed at the point  $P = (x = 0, y = -1.1 \times 10^{-10} \text{ m})$ .

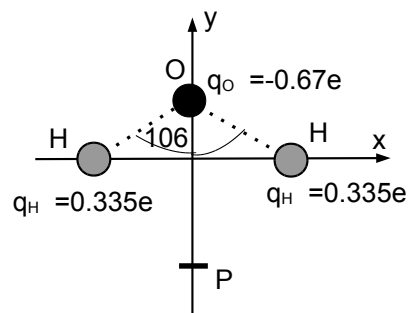

- Find the force on the electron due to the oxygen atom.
- Find the force on the electron due to the two hydrogen atoms.
- Find the net force on the electron due to the water molecule. Is the electron attracted or repelled by the water molecule?

**Problem 3.4:** HCl is a polar covalent molecule with fixed partial charges  $\pm\delta$  (with fixed value  $\delta = 0.18e$ ). When the atoms are in mechanical equilibrium, the atoms are separated by the distance  $l_0 = 0.127 \text{ nm} = 1.27 \times 10^{-10} \text{ m}$ .

a) What bond force  $F_{\text{bond}}^0$  (*vector!*) keeps the HCl molecule at its equilibrium distance?

b) A HCl molecule is placed in a region with a strong, uniform electric field  $E = 65 \times 10^9 \text{ V/m}$ , as shown. The bond between the ions is stretched  $l = 0.134 \text{ nm}$  as a result. The bond force is modified by an elastic contribution  $F_{\text{bond}} - F_{\text{bond}}^0 = F_{\text{spring}} = -\mathcal{K}(l - l_0)$ . Find the spring constant  $\mathcal{K}$ !

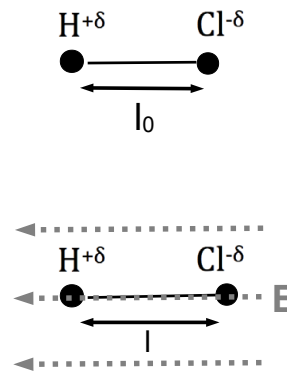

**Problem 3.5:** A dust particle with mass  $m = 7.3 \times 10^{-14} \text{ kg}$  and charge  $Q = +16e$  is released from rest at the top of a vertically placed parallel-plate capacitor. The capacitor plates have dimensions  $13 \text{ cm} \times 13 \text{ cm}$  and the plate distance between is  $d = 5.6 \text{ cm}$ . Ignore effects due to air resistance and edge effects of the electric field.

a) The dust particle is deflected horizontally  $\Delta = 7.0 \text{ mm}$  as it leaves the capacitor. Find the electric field [*vector!*] between the capacitor plates!

b) What is the charge on the capacitor plates?

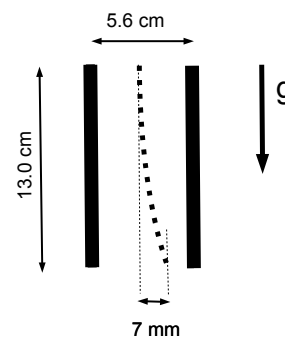

**Problem 3.6:** The charge  $Q_1 = -3.8 \text{ nC}$  is placed at  $(x = 5.3 \text{ cm}, y = 0)$  and a unknown charge  $Q_2$  is placed at the point  $P$  with coordinates  $(x = -6.8 \text{ cm}, y = 0)$  such that the potential is zero  $V = 0$  at the point  $(x = 0, y = 5.1 \text{ cm})$  along the  $+y$ -axis.

a) Find the charge  $Q_2$ .

b) Find the magnitude of the electric fields produced by the charges  $Q_1$  and  $Q_2$  at the point  $(x = 0, y = 5.1 \text{ cm})$ .

c) Find the magnitude and the direction of the total electric field  $\vec{E} = \vec{E}_1 + \vec{E}_2$  at the point  $(x = 0, y = 5.1 \text{ cm})$ .

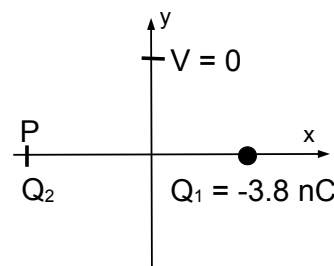

**Problem 3.7:** A capacitor  $C = 8.0 \mu\text{F}$  is connected to a 6.0-V battery.

a) Calculate the charge on the capacitor and the energy stored in the capacitor.

b) At time  $t = 0$ , the capacitor is disconnected from the battery and is connected to an inductor with inductance  $L = 2.3 \text{ mH}$ . At a later time  $t_{1/2}$ , the electric energy stored in the capacitor and the magnetic energy stored in the inductor are equal to each other. Find the charge on the capacitor and the current through the inductor at the time  $t_{1/2}$ .

c) Find the time  $t_{1/2}$ .



**Problem 3.8:** A long-thin wire with current  $I_1 = 3.1$  A is placed at  $(x_1 = -4.0$  cm,  $y_1 = -4.0$  cm); the current  $I_1$  is directed *out-of-the-page*.

- a) Find the magnetic field  $B_1$  at the point  $P$ :  $(x_p = 0, y_p = -4.0$  cm).  
 b) Another long-thin wire with unknown current  $I_2$  *perpendicular-to-the-page* is placed at an unknown location on the  $x$ -axis ( $x_2, y_2 = 0$ ) such that the total magnetic field  $\vec{B} = \vec{B}_1 + \vec{B}_2$  at the point  $P$  is

$$\vec{B} = 18.2 \mu\text{T} \hat{x} + 5.1 \mu\text{T} \hat{y},$$

where  $\hat{x}$  and  $\hat{y}$  are the unit vectors along  $x$  and  $y$ -axes. Find the magnitude and direction of the magnetic field  $\vec{B}_2$  at the point  $P$  produced by  $I_2$ .

- c) Find the location  $x_2$  on the  $x$ -axis of the current  $I_2$  and its magnitude and direction [i.e., *into-the-page* or *out-of-the-page*].

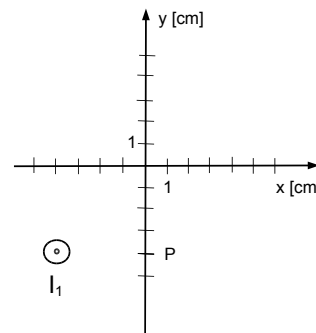

**Problem 3.9:** Three resistors [ $4\Omega$ ,  $3\Omega$ , and  $1\Omega$ ] are connected to two batteries [ $8$  V and  $5$  V], as shown.

- a) Label the circuit and write down the appropriate Kirchhoff's rules.  
 b) Find the currents through all three resistors.  
 c) Find the power delivered by the batteries and the power dissipated in all resistors.

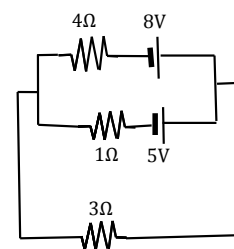

**Problem 3.10:** A beam of protons with various speeds is directed in the positive  $x$  direction. The beam enters a region with a uniform magnetic field  $B = 0.52$  T directed *into-the-page*. We use a uniform electric field [in addition to the magnetic field] to select protons with speed  $v_p = 1.42 \times 10^5$  m/s from this beam - that is, only those protons that pass undeflected by the electric and magnetic fields.

- a) Determine the magnitude and direction of the electric field that yields the desired result.  
 b) The electric field is produced by a parallel-plate capacitor: the plates are square with area  $9.2$  cm  $\times$   $9.2$  cm separated by the distance  $2.5$  cm. What is the charge on the capacitor; which plate is positively charged?  
 c) What are the electric and magnetic energy densities  $u_E$  and  $u_B$  in the region between the capacitor plates?  
 d) Find the ratio of the electric and magnetic energy densities  $u_E/u_B$ ; discuss your result (*open-ended question*).

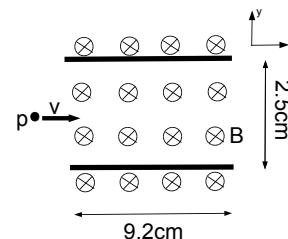

**Problem 3.11:** The track in the figure is a reproduction of the path of a charged particle (mass  $m = 8.3 \cdot 10^{-11}$  kg) in a cloud chamber. The magnetic field is directed *into-the-page* and has magnitude  $B = 0.342$  T. The particle moves in *clockwise* direction. The lead piece decreases the speed of the particle by 20% each time the particle crosses the slab. Ignore the time the particle spends crossing through the lead.

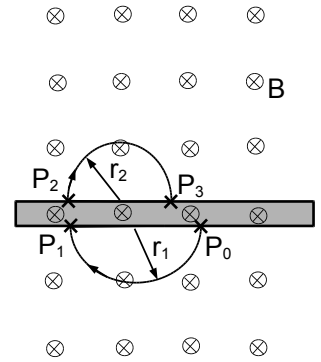

- The particle travels from  $P_0$  to  $P_1$  in a (semi-) circular path with radius  $r = 4.2$  cm in a time of  $t_2 = 32 \mu\text{s}$ . Find the charge of the particle.
- What is the radius  $r_2$  above the lead slab. Find the time for the charged particle to travel from  $P_2$  to  $P_3$ ?
- How many times does the charged particle have to cross until its trajectory follows a (semi-) circular with radius less than 2.0 mm. How long do we have to observe such a small radius of the orbiting charged particle (assume that the particle is at  $P_0$  at the time  $t = 0$ ).

“I studied English for 16 years but...  
...I finally learned to speak it in just six lessons”  
Jane, Chinese architect

ENGLISH OUT THERE

Click to hear me talking before and after my unique course download



**Problem 3.12:** The electric field  $\vec{E}$  at a point  $P$  with coordinates ( $x = 0$ ,  $y = -0.40$  mm) has components

$$E_x = 231 \frac{\text{N}}{\text{C}}, \quad E_y = -137 \frac{\text{N}}{\text{C}}.$$

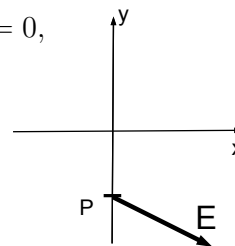

The electric field is produced by a charge on the  $x$ -axis.

- Find the location of the charge.
- Find the charge  $q$  that produces the electric field  $\vec{E}$ .

**Problem 3.13:** Five resistors are connected as shown.

- Calculate the equivalent resistance!
- A 12-V battery is connected between points A and B. Find the power delivered by the battery.
- What is the power dissipated in the  $5\ \Omega$  resistor?

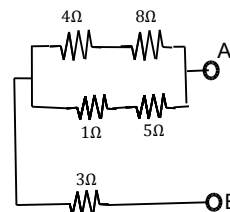

**Problem 3.14:** Two long parallel wires carry the same current  $I$ ; the wires carry current *out-of-the-page* and are placed at  $x = \pm 3.4$  cm.

- The attractive force per unit length between the two wires is  $F/l = 1.2 \times 10^{-4}$  N/m. Find the current  $I$  in the wires.
- A proton is placed on the  $y$ -axis at  $y = 2.0$  cm. The proton travels with speed  $v = 341$  m/s along the  $+y$ -axis. What is the force (*vector*) acting on the proton?

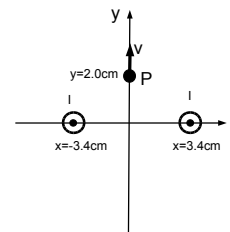

**Problem 3.15:** A capacitor with capacitance  $C = 3.2$  nF connected to an inductor with inductance  $L = 1.3$  mH.

- The capacitor is charged by a 24-V battery. Find the total charge on the capacitor.
- The battery is disconnected at the time  $t = 0$ . At what time is the capacitor fully discharged?
- At what time has the charge on the capacitor dropped to  $1/3$  of its original value?

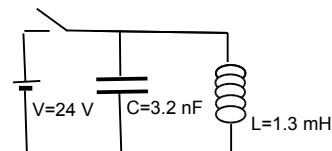

**Problem 3.16:** Magnetic fields produced by two long thin wires: a current  $I_1 = 4.4 \text{ A}$  *out-of-the page* at the origin ( $x = 0, y = 0$ ) and a current  $I_2 = 3.3 \text{ A}$  *into-the-page* at  $x = 2.5 \text{ cm}, y = 0$ .

- Find the magnitudes of the magnetic fields  $\vec{B}_1$  and  $\vec{B}_2$  at the point P with coordinates ( $x_P = 2.5 \text{ cm}, y_P = 3.5 \text{ cm}$ ) produced by the currents  $I_1$  and  $I_2$ , respectively.
- Find the magnitude and direction of the total magnetic field  $\vec{B} = \vec{B}_1 + \vec{B}_2$  at the point P.

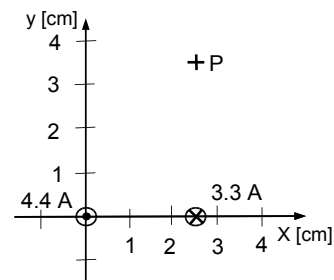

**Problem 3.17:** A parallel plate capacitor with thickness  $d = 4.0 \text{ mm}$  and surface area  $A = 8.0 \text{ cm}^2$  is filled with *Pyrex* glass with dielectric constant  $\kappa = 5.1$ .

- Calculate the capacitance of the filled capacitor.
- The electric field inside the filled capacitor is  $E = 4.5 \text{ kV/m}$ . Calculate the charge  $Q$  on the capacitor.
- Find the electrostatic energy stored in the capacitor.

**Problem 3.18:** An infinitely long thin wire carries the current  $I = 1.4 \text{ A}$  and lies in the  $xy$ -plane. The current wire makes the angle  $\theta = 61^\circ$  with the negative  $x$ -axis.

- Find the magnetic field (*vector!*) at the point P with coordinates ( $x_P = 2.0 \text{ cm}, y_P = 0$ ).
- A particle with mass  $m = 3.8 \text{ mg}$  and charge  $q = 8.3 \text{ nC}$  is at the point P and travels along the  $+y$ -axis with magnitude  $|\vec{v}| = 352 \text{ m/s}$ . Find the acceleration (*vector!*) of the particle.

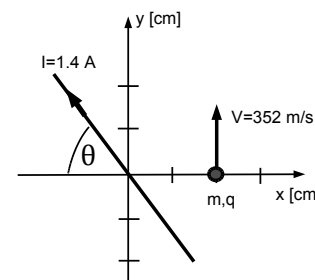

**Problem 3.19:** A  $\text{He}^{2+}$ -ion is placed at the origin ( $x = 0, y = 0$ ) and a  $\text{Cl}^-$  ion is at the coordinates ( $x = 5.0 \text{ cm}, y = 0.0 \text{ cm}$ ).

- An electron is placed between the two ions where its electrostatic potential energy is zero. What is the force (*vector!*) on the electron?
- The electron is released from rest. What is the speed of the electron after it moves the distance  $d = 0.5 \text{ cm}$ ?

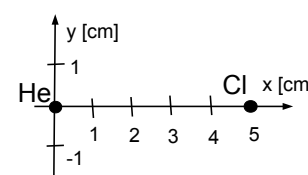

**Problem 3.20:** A particle with mass  $m = 4.8 \text{ g}$  and charge  $q = 1.2 \mu\text{C}$  hangs on a spring with constant  $k = 4.2 \text{ N/m}$  that is suspended from the ceiling. The particle is at the height  $H = 7.3 \text{ cm}$  below the ceiling.

- How much is the spring stretched from its equilibrium length?
- The particle is moved sideways  $d = 4.1 \text{ cm}$  by an (unknown) point charge sitting on the floor at the height  $H = 12.5 \text{ cm}$  below the ceiling. Draw the appropriate free-body diagram for the problem, and find the magnitude and direction of the Coulomb force on the particle.
- Find the location of the charge on the floor.
- Find the charge  $Q$  on the floor.

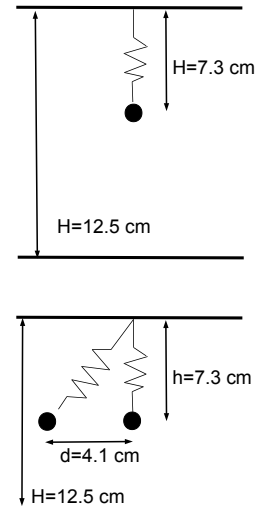



## Sharp Minds - Bright Ideas!

Employees at FOSS Analytical A/S are living proof of the company value - First - using new inventions to make dedicated solutions for our customers. With sharp minds and cross functional teamwork, we constantly strive to develop new unique products - Would you like to join our team?

FOSS works diligently with innovation and development as basis for its growth. It is reflected in the fact that more than 200 of the 1200 employees in FOSS work with Research & Development in Scandinavia and USA. Engineers at FOSS work in production, development and marketing, within a wide range of different fields, i.e. Chemistry, Electronics, Mechanics, Software, Optics, Microbiology, Chemometrics.

**We offer**  
A challenging job in an international and innovative company that is leading in its field. You will get the opportunity to work with the most advanced technology together with highly skilled colleagues.

Read more about FOSS at [www.foss.dk](http://www.foss.dk) - or go directly to our student site [www.foss.dk/sharpminds](http://www.foss.dk/sharpminds) where you can learn more about your possibilities of working together with us on projects, your thesis etc.

The Family owned FOSS group is the world leader as supplier of dedicated, high-tech analytical solutions which measure and control the quality and production of agricultural, food, pharmaceutical and chemical products. Main activities are initiated from Denmark, Sweden and USA with headquarters domiciled in Hillerød, DK. The products are marketed globally by 23 sales companies and an extensive net of distributors. In line with the corevalue to be 'First', the company intends to expand its market position.



**Dedicated Analytical Solutions**

FOSS  
Slangerupgade 69  
3400 Hillerød  
Tel. +45 70103370  
[www.foss.dk](http://www.foss.dk)



**Problem 3.21:** Four resistors [ $2\ \Omega$ ,  $3\ \Omega$ ,  $4\ \Omega$ , and  $6\ \Omega$ ] are connected to a 8-V and a 2-V battery as shown.

- Label the circuit and write down Kirchoff's laws.
- Find the currents in the circuits.
- Find the power delivered by the batteries.

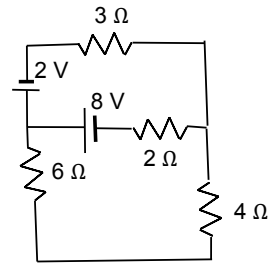

**Problem 3.22:** The rails of of horizontal track are separated by  $l = 13\text{ cm}$ . The track is connected to a capacitor with capacitance  $C = 25.5 \times 10^{-3}\text{ F}$  that is charged by a battery with EMF  $V_0 = 12\text{ V}$ . The system is placed in a homogenous magnetic field  $B = 3.4\text{ T}$  – *into the page*]. A conducting rod [with mass  $m = 2.6\text{ g}$  and resistance  $R = 63\ \Omega$ ] glides frictionless on the track.

- What is the acceleration (*vector*) of the rod at the initial time  $t = 0$  when the capacitor is connected to the rail.
- The maximum speed of the rod is  $v_{\max} = 17.8\text{ m/s}$ . What charge remains on the capacitor?
- What fraction of the electrostatic energy lost in the capacitor and is converted into kinetic energy of the rod as the rod is accelerated?

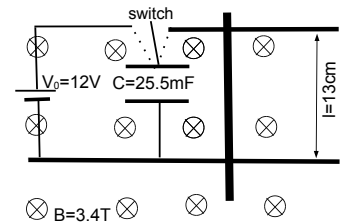

**Problem 3.23:** A dust particle with mass  $m = 0.2\text{ g}$  carries an unknown charge  $Q$ . It is attached to an insulating silk thread with length  $l = 22\text{ cm}$ . The dust particle is swung around a vertical axis, as shown. A homogeneous magnetic field with strength  $B = 25\text{ T}$  points downwards.

- Draw the free-body diagram for the dust particle and write down Newton's second law.
- The silk thread makes the angle  $\theta = 27^\circ$  with the vertical when the dust particle completes on revolution in the time  $\tau = 1.86\text{ s}$ . Find the the tension in the string.
- Find the charge  $Q$  of the dust particle.

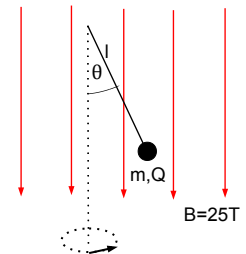

**Problem 3.24:** A parallel-plate capacitor (with capacitance  $C = 12.3 \text{ pF}$  and distance  $d = 3.7 \text{ mm}$  between plates) has an opening in the middle used to shoot ions through the capacitor. A singly-ionized phosphorus ion  $\text{P}^+$  (mass  $m_{\text{P}} = 31 \text{ u}$ ) enters the capacitor with velocity  $v_0 = 1.82 \times 10^4 \text{ m/s}$ . The ion leaves the capacitor after the time  $\Delta t = 0.31 \text{ } \mu\text{s} = 3.1 \times 10^{-7} \text{ s}$ .

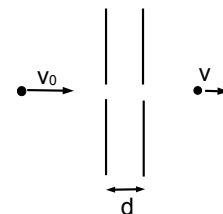

- What is the velocity of the phosphorus ion as it leaves the capacitor?
- What is the force (*vector*) on the phosphorus ion?
- What is the charge on the capacitor? Which plate is *positively* charged?

**Problem 3.25:** The charge  $Q_1 = 4 \text{ nC}$  is placed at  $(x = 0, y = 5.0 \text{ cm})$  and the charge  $Q_2 = 6 \text{ nC}$  is placed at  $(x = 6.0 \text{ cm}, y = 4.0 \text{ cm})$ .

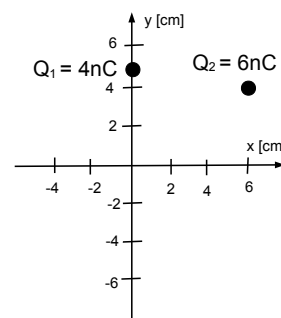

- Sketch the electric field vectors  $\vec{E}_1$  and  $\vec{E}_2$  produced by  $Q_1$  and  $Q_2$ , respectively, and the total electric field  $\vec{E}_{\text{total}} = \vec{E}_1 + \vec{E}_2$ .
- Find the electric field  $\vec{E}_{\text{total}} = \vec{E}_1 + \vec{E}_2$  (both magnitude and direction) at the origin.
- We place a charge  $Q_0 = -2.1 \text{ nC}$  such that the new total electric field at the origin is zero  $\vec{E}'_{\text{total}} = \vec{E}_0 + \vec{E}_1 + \vec{E}_2 = 0$ . Find the coordinates  $(x_0, y_0)$  of the location of the charge  $Q_0$ .

**Problem 3.26:** A small ball with mass  $m = 5.5 \text{ g}$  and charge  $Q = 85 \text{ nC}$  is suspended by a string of negligible mass of length  $L = 13 \text{ cm}$ . Another small ball with unknown charge  $q$  is moved very slowly from far away until it is in the original position of the first ball. The first ball is deflected away from the vertical until it reaches the height  $h = 3.0 \text{ cm}$ .

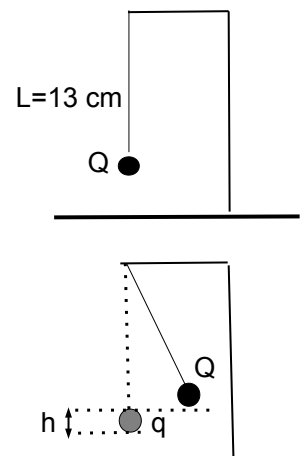

- Draw the free-body diagram for the first ball and write down Newton's second law for the first ball.
- Find the tension in the string and the charge  $q$  of the second ball.
- How much work has been done (*by us!*) as the second ball  $q$  is moved from far away to the original position of the first ball  $Q$ ?

**Problem 3.27:** An infinitely long wire with current  $I = 2.3 \text{ A}$  along the  $-z$ -axis [into-the-page] is placed on the  $x$ -axis at  $(x = 2.0 \text{ cm}, 0)$ .

- Find the magnetic field  $\vec{B}$  at  $P$  with coordinates  $(x = 1.0 \text{ cm}, 2.0 \text{ cm})$ .
- A dust particle with mass  $m = 4.7 \times 10^{-8} \text{ kg}$  and charge  $q = -3.7 \text{ nC} = -3.7 \times 10^{-12} \text{ C}$  is at the point  $P$  and travels with speed  $v = 1291 \text{ m/s}$  along the  $+y$ -axis. Find the acceleration (vector) of the dust particle!

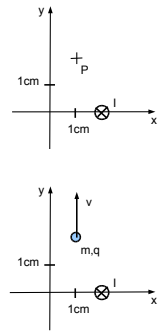

**Problem 3.28:** Two unknown charges  $q_1$  and  $q_2$  are placed at the origin  $(x_1 = 0, y_1 = 0)$  and along the  $x$ -axis at  $(x_2 = 3 \text{ cm}, y_2 = 0)$ , respectively. You move a potassium ion  $\text{K}^+$  [mass  $m = 39 \text{ u}$ ] (infinitely) slowly from the point A  $(x_A = 6 \text{ cm}, y_A = 0)$  to the point B  $(x_B = 4 \text{ cm}, y_B = 0)$  along the  $x$ -axis. Then you move it along a circular path to the point C  $(x_C = 0, y_C = 4 \text{ cm})$ .

- You do the work  $W_{BC} = 367 \text{ eV}$  to move  $\text{K}^+$  from B to C. Find the charge  $q_2$ .
- You do the work  $W_{AB} = 343 \text{ eV}$  to move  $\text{K}^+$  from A to B. Find the charge  $q_1$ .
- The potassium ion is released from rest at the point C. What is the speed of the potassium ion when it is far away from two charges  $q_1$  and  $q_2$ ?

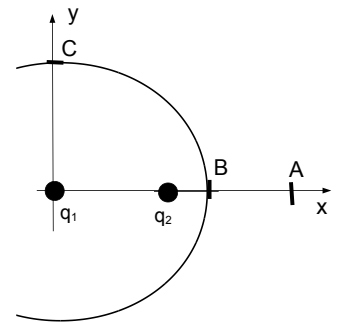



**Problem 3.29:** A capacitor has plates with cross-sectional area  $A = 1.8 \text{ cm} \times 1.8 \text{ cm}$  separated by the distance  $d = 2.7 \text{ mm}$ . The capacitor is filled with material with dielectric constant  $\kappa = 7.3$ .

- The capacitor is connected to a 12-V battery. Find the charge on the capacitor!
- The battery is disconnected and the dielectric material is removed. What is the potential difference across the capacitor plates?
- What work have *you* done while removing the dielectric material?
- What is the magnitude and direction of the (average) electric force acting on the dielectric slab?

**Problem 3.30:** In the Bohr model of the hydrogen atom, the electron moves around the proton. We view the motion from the electron's point of view: the electron "sees" a proton orbiting in *clockwise* direction.

- The proton circles on a circular orbit with radius  $r = 5.3 \times 10^{-11} \text{ m}$  at the speed  $v = 2.2 \times 10^6 \text{ m/s}$ . What is the period  $T$ ?
- The orbiting proton can be considered as a wire loop with current  $I_{\text{eff}} = e/T$ . What is the magnetic field produced by the orbiting proton at the location of the electron.
- Find the ratio of the magnetic field at the position of the electron and the angular momentum of the proton:  $\chi = B/L$ .

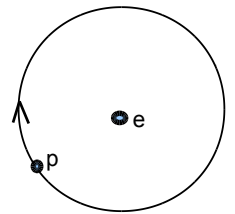

**Problem 3.31:** A water molecule is shown. The angle between the OH-bonds is  $\theta = 106^\circ$  and the OH-distance is  $d = 9.42 \times 10^{-11} \text{ m}$ .

The charges on the oxygen and hydrogen are fractions of the elementary charge ("partial charge")  $q_O = -0.67e$  and  $q_H = 0.335e$ , respectively. An electron is placed at the point  $P : (x = 0, y = -1.1 \times 10^{-10} \text{ m})$ .

- What is the potential energy of the electron at the origin ( $x = 0, y = 0$ ) and at the point  $P$ ?
- What is the force on the electron placed at the origin? Sketch the electrostatic potential energy as a function of the  $y$ -coordinate of the electron; discuss the graph.
- What is the minimum speed of the electron at the point  $P$  so that it reaches the origin?

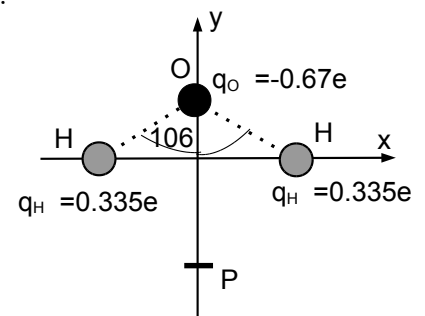

**Problem 3.32:** A potassium ion  $K^+$  (mass  $m = 39 \text{ u}$ ) travels in the  $(x, y)$ -plane. At time  $t = 0$ , the ion enters a region with uniform *electric or magnetic* field with velocity  $v_{x,0} = 5,413 \text{ m/s}$  and  $v_{y,0} = 0$ . The electric field points along the  $+y$ -axis. At time  $t^*$ , the ion is at the point  $P$  with  $(x_p = 1.5, \text{ cm}, y_p)$ ; the coordinate  $y_p$  is not known. The velocity  $\vec{v}$  makes the angle  $\theta = 22^\circ$  with respect to the  $+x$ -axis.

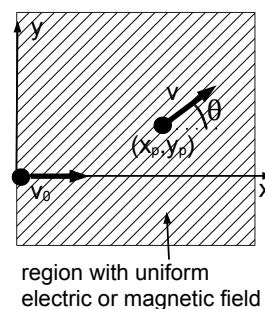

- The potassium ion is deflected due to a uniform electric field in the  $+y$  direction. Find the magnitude of the electric field.
- The potassium ion is deflected due to a uniform magnetic field directed into-the-page. Find the magnitude of the magnetic field.
- Find the vertical deflection  $y_p$  of the potassium ion in both cases.

**Problem 3.33:** An atomizer [spray] is used to generate oil droplets that are charged via the exposure to  $X$ -rays. above a parallel-plate capacitor. Assume that the electric field inside the capacitor is uniform. The oil droplets fall through a small hole in the upper plate. The voltage on the capacitor is adjusted such that the oil droplets are suspended in air, i.e., they do not move. The plates of the capacitor have an area  $A = 5.5 \text{ cm}^2$  and are separated by the distance  $d = 2.5 \text{ cm}$ . Assume that the mass of the oil drop is  $m = 1.2 \times 10^{-15} \text{ kg}$ , and the charge is  $q = -1e$ . Neglect edge effects of the electric field.

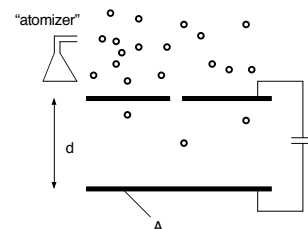

- Draw the free-body diagram for the oil drop! Find the electric field (*vector!*) necessary to keep the oil drop suspended.
- Find the potential difference between the upper and lower plate. Which plate is at the *higher* potential?
- Find the charge on the parallel-plate capacitor.

**Problem 3.34:** A  $8\mu\text{F}$  capacitor is connected to a  $V_0 = 12 \text{ V}$  battery.

- Find the charge on the capacitor and the stored energy.
- At time  $t = 0$ , the battery is disconnected and a  $R = 6.0 \text{ M}\Omega$  resistor is attached. Find the charge on the capacitor and the voltage across the capacitor at time  $t = 2.0 \text{ s}$  and what is the (average) current through the resistor from  $t = 0$  to  $t = 2.0 \text{ s}$ .
- What is the energy dissipated in the  $6.0 \text{ M}\Omega$  resistor from  $t = 0$  to  $t = 2.0 \text{ s}$ ?

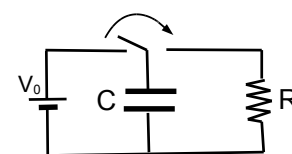

**Problem 3.35:** A  $\text{Na}^+$  ion is placed at  $x = 10 \text{ nm}$  and a  $\text{K}^-$  is placed at  $x = -25 \text{ nm}$ , as shown.

- Find the electrostatic potential at the origin  $x = 0$ .
- An electron with velocity  $\vec{v} = -2.1 \times 10^5 \text{ m/s} \vec{e}_x$  is placed at the origin. What is the electrostatic potential energy, the kinetic energy, and the total energy of the electron?
- The electron travels towards the  $\text{K}^-$  ion. What is the speed of the electron when the electron is at  $x = -2.5 \text{ nm}$ .

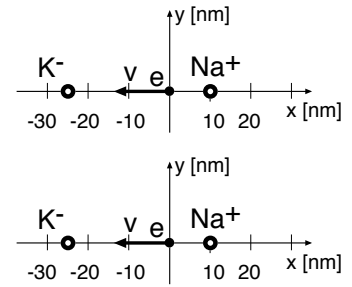

**Problem 3.36:** Gel electrophoresis is used to separate proteins. Proteins are placed in an agarose hydrogel with viscosity  $\eta = 2.2 \text{ Pa}\cdot\text{s}$ . The motion of the protein is damped and the drag force is given by Stokes' law  $F_{\text{drag}} = 6\pi\eta av$ , where  $a$  is radius of the protein. The charge on the protein is  $Q = 100e$ . The protein drifts when the electric field of strength  $E = 5.2 \text{ V/cm}$  is applied.

- The protein travels 2.4 mm in 3.4 h. Find the radius  $a$  of the protein!
- Another protein has a radius  $a'$  that is 25% bigger:  $\Delta a/a = (a' - a)/a = 0.25$ . Find the separation of the two proteins after 3.4 h. Assume that the charge on the protein is fixed  $Q = 100e$ .

# The Wake

the only emission we want to leave behind

[Low-speed Engines](#) [Medium-speed Engines](#) [Turbochargers](#) [Propellers](#) [Propulsion Packages](#) [PrimeServ](#)

The design of eco-friendly marine power and propulsion solutions is crucial for MAN Diesel & Turbo. Power competencies are offered with the world's largest engine programme – having outputs spanning from 450 to 87,220 kW per engine. Get up front! Find out more at [www.mandieselturbo.com](http://www.mandieselturbo.com)

Engineering the Future – since 1758.  
**MAN Diesel & Turbo**



**Problem 3.37:** A No. 12 AMG (*American Wire Gauge*) copper wire with diameter  $d = 2.05 \text{ mm}$  and resistance per length  $R/L = 5.211 \text{ m}\Omega/\text{m}$  carries a 1.0-A current.

- Calculate the number of electrons flowing across the cross-section per unit time.
- Estimate the drift speed of electrons, assuming that every copper atom contributes one “conduction electron.” Useful quantity: lattice constant of Cu:  $a = 0.36 \text{ nm}$ .
- Compare the drift speed to the the thermal speed of electrons at room temperature.

**Problem 3.38:** An incline at the angle  $\theta = 13^\circ$  with two rails separated at the distance  $l = 23 \text{ cm}$  is an region with magnetic field  $B = 3.2 \text{ mT}$ .

The rails are connected by a resistance  $R = 4.1 \text{ m}\Omega$ . A copper rod with mass  $m = 2.1 \text{ g}$  rolls down the incline with a constant unknown speed  $v$ . Ignore the resistance of the rails and the rod.

- Draw the free-body diagram for the rod.
- Find the current [*magnitude and direction*] through the rod.
- Find the speed of the rod.

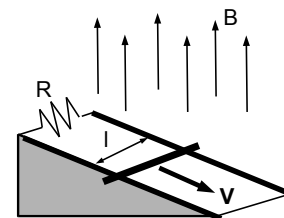

**Problem 3.39:** The plates of a parallel-plate capacitors are placed at  $x = \pm 4.0 \text{ cm}$ . The area of the plates are  $A = 0.15 \text{ m}^2$ . The right plate is grounded, i.e.,  $V = 0$ . The potential of the left plate is not known. At time  $t = 0$ , an oxygen ion is placed at the origin ( $x = 0$ ,  $y = 0$ ) with initial speed  $v_0 = 4300 \text{ m/s}$ . The ion travels between the plates until it hits the left plate with speed  $v_1 = 6800 \text{ m/s}$ . The mass of the oxygen ion is  $m = 16.0 \text{ u}$ .

- Find the electrostatic potential at the origin.
- What is the charge on the capacitor plates? Which plate is positively charged?
- The  $\text{O}^+$ -ion hits the capacitor plate on the left at the time  $t = 8.0 \mu\text{s}$ . How far from the  $x$ -axis does the oxygen ion hit the plate?

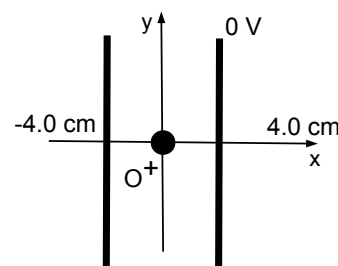

**Problem 3.40:** A circular loop of wire (radius  $r = 5.0 \text{ cm}$ ) is placed in a region of uniform magnetic field  $B = 2.0 \text{ T}$ . The magnetic field is perpendicular to the plane of the loop.

- Calculate the magnitude of the magnetic flux through the area of the circle.
- The loop is rotated by  $180^\circ$  during a time interval  $\Delta t = 0.5 \text{ s}$ . Find the (average) *EMF* induced in the wire loop.
- The wire loop has resistance  $R = 0.1 \Omega$ . Find the energy dissipated in the wire. Where does this energy come from?

#### 4: WAVES, SOUND, AND LIGHT

**Problem 4.1:** A string with mass  $m = 1.5$  g and length  $L = 0.84$  m is fixed at both ends. A vibrator generates a pattern as shown.

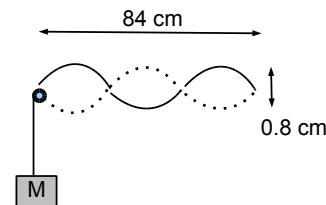

- A mass of  $M = 120$  g is attached to the string and hangs from a pulley. Find the speed of the transverse waves along the string.
- What are the maximum speed and maximum acceleration of the *up-and-down* motion of the string?
- Make reasonable assumption(s) and find an approximate value for the force in the *up-and-down* direction. Is this a reasonable value?

**Problem 4.2:** A transducer emits ultrasound pulses that enter the human body. These pulses are reflected at interfaces between different organs and are then received as “echoes” in the transducer. The time between sending the original pulse and receiving the echoes are  $5.2 \times 10^{-5}$  s and  $9.6 \times 10^{-5}$  s, respectively. Assume that the (average) speed of sound is 1,540 m/s along the pathway.

- How far from the transducer are the respective interfaces?
- What is the size of the organ in the direction of the path of the ultrasound?
- The ultrasound has a wavelength  $\lambda = 0.56$  mm. How many oscillations does the transducer produce between the arrival of the two echoes?

**Problem 4.3:** An organ pipe is open on one side and closed on the other side. We use a microphone vibrating at 576 Hz to produce sound. Use the speed of sound in air  $v = 343$  m/s.

- The organ pipe is producing the third harmonic. Sketch the displacement of air molecules inside the organ pipe!
- What is the length of the organ pipe?
- Both sides of the organ pipe are opened. What is the lowest frequency the organ pipe can now produce?

**Problem 4.4:** Colby and Harry are on a romantic vacation at the beach. They are ankle deep  $d = 15$  cm in the water.

- What is the wave speed at the depth of Colby and Harry?
- Colby and Harry hold hands while walking parallel to the beach. They are at a distance 1.61-m from each other. They notice that two consecutive wave crests hit their legs at the same time. How many wave crests hit their legs during one minute?
- Colby and Harry now wade deeper into the water so that their chest are submerged at the depth  $d = 1.3$  m. Colby and Harry keep the distance between them. Describe the part of the wave [crest, trough, etc] encountered by Harry at the moment when a crest hits Colby.

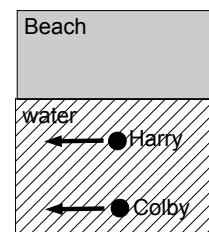

**Problem 4.5:** Beads with mass  $m = 0.42$  g are secured on massless string at equal 2.0-cm distance. The total string has length 3.0-m. The tension in the string is 6.2 N. A travelling transverse wave with wavelength  $\lambda = 34$  cm and amplitude  $A = 4.1$  mm forms along the string.

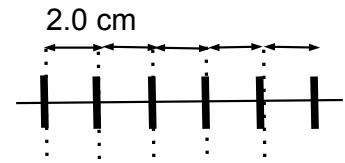

- What is the speed of the transverse wave along the string.
- What is the maximum speed of a bead along the string?
- What is the maximum force exerted on each bead.

**Problem 4.6:** Many insects generates characteristic frequencies of sound waves by the up-and-down movement of their wings. We assume that the characteristic frequency is  $f_{\text{insect}} = 96$  Hz. Spiders detect the presence of prey by tuning the fundamental frequency of the silk threads of their web to the frequency of the prey. The mass per unit length of silk thread is  $m/L = 0.14$  dtex = 0.14 g per 10,000 m.

- The silk thread is 14.0-cm long. What is the tension  $T_0$  in the silk thread that would produce the desired frequency?
- The spider web contains silk threads of different lengths, ranging in length from  $L_s = 9.5$  cm to  $L_l = 19.5$  cm. Assume that the tension in the threads are identical to the value found in **a)**. What is the smallest and largest frequency that can be detected by the spider?
- The spider can increase or decrease the tension in the threads by 20%. What is the smallest and largest frequency that can be detected by the spider?

I joined MITAS because  
I wanted **real responsibility**

The Graduate Programme  
for Engineers and Geoscientists  
[www.discovermitas.com](http://www.discovermitas.com)



**Month 16**

I was a construction  
supervisor in  
the North Sea  
advising and  
helping foremen  
solve problems

Real work  
International opportunities  
Three work placements



 **MAERSK**



Click on the ad to read more

**Problem 4.7:** The waves on the surface of the ocean have wavelength  $\lambda = 40.0$  m and are travelling *eastward* at a speed of 16.5 m/s.

- A ship is anchored. At what time intervals does the ship encounter the wave crests?
- A ship is traveling *westward* at a speed of 5.0 m/s. At what time intervals does the ship encounter the wave crests?
- How fast and in what direction [that is, *east-* or *west-*ward] is the ship traveling if it encounters 22 wave crests every minute?

**Problem 4.8:** A transducer emits ultrasound pulses that enter the human body. The frequency produced by the transducer is 3 MHz. These pulses are reflected at interfaces between different organs and are then received as “echoes” in the transducer. Assume that the (average) speed of sound is 1,540 m/s along the pathway.

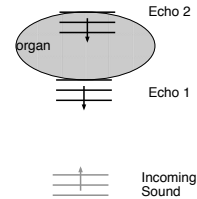

- The transducer produces 84 oscillations between receiving echoes 1 and 2. What is the time between receiving the echoes?
- What is the size of the organ detected by the echoes?
- How many oscillations are observed between the two echoes produced by the smallest anatomical feature that can be detected by the ultrasound? [Make reasonable assumption].

**Problem 4.9:** A body at the absolute temperature  $T$  radiates heat in the form of electromagnetic waves, mostly in the infrared part of the spectrum [so called *blackbody radiation*]. The intensity is proportional to the fourth power of temperature  $T^4$ :  $S = \sigma T^4$ , where  $\sigma = 5.67 \times 10^{-8}$  W/(m<sup>2</sup> K<sup>4</sup>) is the Stefan-Boltzmann constant (blackbody radiation). It is independent of the type of material, and applies to the human body, metals, ...

- The oven temperature during baking is set at  $T = 450$  K (350°F). What is the energy density (energy per volume) of the infrared radiation?
- What is the strength of the electric field inside the oven?
- The inside of the oven has dimension 60 cm  $\times$  40 cm  $\times$  50 cm. What is the total energy of the electromagnetic radiation inside the oven. Compare the total electromagnetic energy with the internal energy of the air inside the oven. (Treat air as a diatomic gas.)

**Problem 4.10:** The power of the lens in the eyes can be adjusted by tensing the muscles. The power of *Colby's* lens varies between 56 diopters when the muscles are relaxed and 58 diopters when the muscles are tensed.

- Colby's retina is 1.8 cm behind the lens. What is the vision of Colby? Does she have normal vision or does she need prescription eye glasses?
- Colby chooses a fashionable pair of glasses that sits 2.0-cm in front of her eyes. What prescription does she need? If corrected for reading, assume that she reads a book 20.0 cm in front of her eyes.
- Colby watches her best friend Harry who sits 2.0-m away from her. What is the power of the lens in her eyes while she observes Harry *with* her prescription glasses on?

**Problem 4.11:** A source produces light with frequency  $f = 5.25 \times 10^{14}$  Hz. The light beam strikes a double-slit with spacing 0.035 mm. The interference pattern is observed on a screen at a distance 1.5 m.

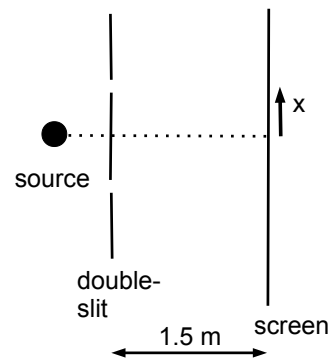

- Find the position on the screen (i.e., the coordinate  $x$ ), where the first dark fringe is observed away from the forward direction.
- The entire apparatus is immersed in a fluid with unknown index of refraction. It is observed that the first dark fringe moves 3 mm towards the center line so that  $x' = 9$  mm. What is the index of refraction of the fluid?

**Problem 4.12:** An octave describes a certain range of frequencies. In Western music, the range is based on the musical tone  $C$ . The first seven octaves are:

Scientific Designation	Octave name	$f_{\min}$ [Hz]	$f_{\max}$ [Hz]
$C_0$	Subcontra	16.4	32.7
$C_1$	Contra	32.7	65.4
$C_2$	Great	65.4	130.8
$C_3$	Small	130.8	261.8
$C_4$	One-lined	261.6	523.6
$C_5$	Two-lined	523.6	1046.5
$C_6$	Three-lined	1046.5	2093.0

- Assume that the organ pipe is open on both sides and  $v = 343$  m/s for the speed of sound in air. Find the lengths of organ pipes such that the octave  $C_1$  (Contra) is produced as the first harmonic.
- An organ pipe manufacturer produces pipes of variable length longer than 16 cm. Your living room can accommodate pipes that are shorter than 1.4 m. What is the range of frequencies that the organ pipes in your living room can produce?
- For most pianos, the lowest octave is  $C_1$  (Contra). What is the lowest complete octave that the organ pipes in your living room can produce? What is a *practical* conclusion of your result? (*Open-ended question*).

**Problem 4.13:** *Exoplanets* are recently discovered planets that orbit stars other than “our” sun. The closest star from the sun (and thus Earth) is Proxima Centauri at a distance  $R = 4.2$  lightyears  $= 2.74 \times 10^{16}$  m from the Earth.

- You use a 6-m telescope in the visible part of the spectrum [ $\lambda = 530$  nm]. What is the size [diameter] of the smallest exoplanet of Proxima Centauri that you could observe with the telescope? *Compare to the size of Jupiter  $r_{\text{Jup}} \simeq 70,000$  km!*
- What wavelength would have to use if you want to see an exoplanet of the size of Jupiter near Proxima Centauri using your 6-m telescope?
- What is the closest distance from which you can see Jupiter with visible light using the 6-m telescope? Assume green color. *Compare to the distance to Proxima Centauri!*



**Problem 4.14:** Colby is a 3rd-grader who wears eyeglasses with prescription  $-0.75$  diopters. The frames are  $2.0$  cm in front of her eyes. The distance between the lens in her eyes and the retina is  $1.9$  cm.

- She needs to sit in the front row so that she can see the writing on the blackboard  $2.3$ -m away from her desk. What is her far point?
- Colby does not wear her eyeglasses during a boat trip and looks at a lighthouse far away. Where is the image formed by the lens in her eyes when her muscles are completely relaxed? *Interpret your result!*
- Colby sees her optometrist. What is her new prescription?

**Problem 4.15:** A ray is incident on a slab of glass that is  $3.0$ -cm thick. The angle of incident is  $\theta = 54^\circ$ . The ray is refracted when entering and leaving the slab; the two rays in air above and below the glass slab are parallel to each other. The rays in air are displaced  $1.0$  cm.

- What is the index of refraction of the glass?
- The incident angle is increased to  $\theta' = 64^\circ$ . Find the displacement of the ray leaving the slab of glass.

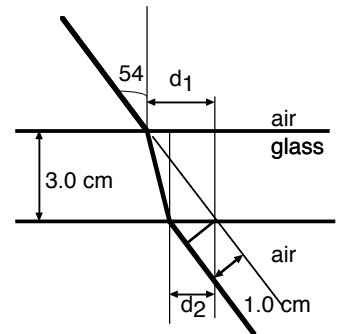

www.job.oticon.dk

**oticon**  
PEOPLE FIRST



**Problem 4.16:** An upright 5-cm tall image of 15-cm tall object is produced by an unknown lens. The object and image are separated by 12 cm.

- Draw the appropriate rays to find the location of the lens and to determine the type and focal length of the lens.
- Describe each step.
- The location of the object is now changed and the lens stays fixed. *Calculate* the size of the image when the separation between object and image is 5.0 cm.
- Use ray tracing to confirm your calculation in part c).

**Problem 4.17:** The retina in Harry's eyes is 2.1 cm behind the lens in his eyes. The power [strength] of the lens in his eyes varies by changing the tension in the eyes muscles between  $P_{\min} = 47.6$  diopters and  $P_{\max} = 49.5$  diopters.

- Calculate Harry's near- and farpoint. Is Harry near- or far-sighted?
- Harry sees his optometrist so that he can look at objects far away and read a book at the distance 25-cm from his eyes. Harry wears his eyeglasses 2.0-cm from the lens in his eyes. What prescription does Harry get from his optometrist?

**Problem 4.18:** A 3.0-cm tall object is placed in front of a mirror; an upright, 2.0-cm tall image is formed 8.0-cm away from the object.

- Use ray tracing to find the focal length of the mirror. Is the mirror concave or convex?
- The mirror is kept fixed. How much do you have to move the object so that the image is upright and 1.0-cm tall?

**Problem 4.19:** During the day, the pupils of a person have a diameter  $D = 1.8$  mm.

The red tail lights of a car are separated by the distance  $d = 1.3$  m.

- The frequency of the red light is  $f = 4.4 \times 10^{14}$  Hz. Calculate the wavelength.
- How far away can the car be located so that the two lights can be resolved by the pupil?
- During the night, the opening of the pupil is three times as large. How far away can the car be located at night so that the two tail lights can be resolved?

**Problem 4.20:** An object is 2 cm tall. A single lens/mirror is hidden inside a (*opaque!*) black box and produces an image that is 5 cm tall and upright. The image is 8.0 cm to the *right* of the object.

- What type of lens/mirror is used to produce the image?
- Use ray-tracing to find the location of the lens/mirror and the focal length. Describe (i) how the location and (ii) the focal length of the lens/mirror are found by ray tracing.
- Find the focal length of the lens/mirror hidden inside the black box!

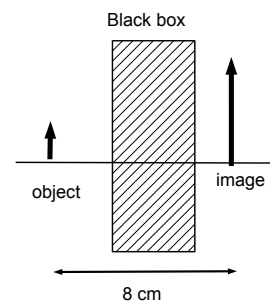

**Problem 4.21:** The maximum value of the electric field of an electromagnetic wave is  $E = 750 \text{ V/m}$ . Use  $L = 33.5 \times 10^4 \text{ J/kg}$  for the latent heat of ice and  $\rho = 917 \text{ kg/m}^3$  for the density of ice.

- What is the maximum value of the magnetic field of the electromagnetic wave?
- Calculate the intensity of the electromagnetic wave.
- An ice cube with dimension  $a = 1.0 \text{ cm}$  is placed in the path of the electromagnetic wave. How long does it take for the light to melt the ice cube? Discuss your result. *Open-ended question.*

**Problem 4.22:** A 2.4-cm tall object is placed in front of a concave spherical mirror with radius of curvature  $R = 14.5 \text{ cm}$ .

- An upright image is formed by the mirror. What are the smallest and largest possible values of the distance between object and the mirror?
- The image is formed 21-cm away from the object. What is the distance between object and mirror?
- What is the image height?

**Problem 4.23:** A diffraction grating with 8600 lines per centimeter is illuminated at normal incidence with white light [wavelengths range from 400 nm (violet) to 700 nm (red)].

- For how many orders can one observe the complete spectrum in the transmitted light?
- Do any of these orders overlap? That is, does the sequence of the colors follow the normal ordering?
- You use another diffraction grating such that the complete fourth-order of the spectrum can be observed. Calculate the number of lines per centimeter of the other grating.

**Problem 4.24:** Harry and Charlie are identical twins except for their vision. The retina is 1.8 cm behind the pupil in the eye. Harry's prescription is -1.0, whereas Charlie's prescription is +1.0. We use standard convention so that object can be seen clearly between 25-cm and 'infinity' measured from the eyes. Harry and Charlie wear identical eyeglasses (in appearance) at the distance 2.0 cm in front of their eyes.

- Find the range of the power of Harry's and Charlie's eyes.
- Harry accidentally wears Charlie's glasses. What is the range of object distances that Harry can see clearly?
- Charlie accidentally wears Harry's glasses. What is the range of object distances that Charlie can see clearly?

**Problem 4.25:** The propagation of (light) rays can be compared to the propagation of an object, for example a person, at some constant velocity. We use this analogy to analyze Snell's law of refraction. A lifeguard observes the beach from a seat 9.3 m away from the lake. She can run at a speed of  $v_{\text{run}} = 8.9 \text{ m/s}$  and swim at a speed of  $v_{\text{swim}} = 1.25 \text{ m/s}$ . A swimmer is drowning and needs to be rescued: he is 7.2 m from the beach and 8.2 m along the beach away from the life guard.

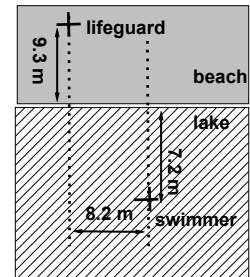

- The lifeguard takes a straight-line path. How long does it take her to arrive at the swimmer?
- The lifeguard now takes the path so that she arrives at the swimmer in the *shortest* time. Where does she enter the lake?
- What is the shortest time for the lifeguard to reach the swimmer?

**Problem 4.26:** We use ultrasound waves with frequency  $f = 41 \text{ kHz}$ . Transducer #1 is opposite a microphone at the distance 4.20 cm. A second transducer #2 is placed at the (unknown) distance  $x$  from #1 along the horizontal. The two transducers vibrate *in-phase*. Use  $v_{\text{air}} = 343 \text{ m/s}$  and  $v_{\text{water}} = 1497 \text{ m/s}$  for the speed of sound in air and water, respectively.

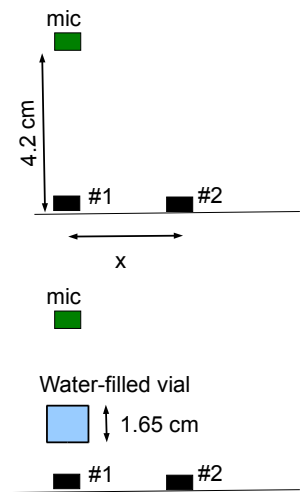

- Find the smallest distance  $x$  so that no sound is picked up by the microphone.
- Calculate the time delay when wave crests produced by #1 and #2 arrive at the microphone. *Explain your result!*
- Both transducers and the microphone are held in place. A water-filled vial (size  $d = 1.65 \text{ cm}$ ) is placed in the path between #1 and the microphone. Calculate the time delay when wave crests produced by #1 and #2 arrive at the microphone.
- Interpret the result in c)! Ignore the attenuation of sound inside the vial.

**Problem 4.27:** Low-level laser therapy (LLLT) is an experimental therapy to stimulate cellular function. The intensity of the laser is  $25 \text{ mW/cm}^2$ .

- What is the magnitude of the electric field of the light? Use the rms value.
- The laser irradiates a circle with radius  $a = 2.4 \text{ mm}$  with a 75-ms pulse. What is the energy deposited in the tissue?

**Problem 4.28:** Emmy is trying to complete her report for the experiments with lenses; her record is incomplete: she forgot to write down the type and focal lengths of the lenses she used in the experiment. Her record for the images, the position  $x$  along the principal axis, and the image heights  $h$  reads:

	real/imaginary	$x$ [cm]	$h$ [cm]
object	n/a	0	4.0
intermediate	real	7.0	-2.0
final	real	18.0	5.0

- Draw the ray diagram for the problem.
- Use the ray diagram to find the focal lengths of the two lenses. What is the distance between the two lenses? What are the object and image distances.
- Emmy did not finish the second part of the lab, where she was supposed to move the object one centimeter further to the left, while leaving the two lenses unchanged. Find the location of the intermediate and final image along the principal axis.

**Problem 4.29:** A hemispherical metal is polished on both sides so that it can be used as either a concave or a convex mirror. The radius of the sphere is  $R = 12.0$  cm

- An object of height 3.0 cm is placed at the distance 8.5 cm in front of the mirror when used as a concave mirror. What is the height of the image produced by the mirror?
- The hemisphere is flipped and the object faces a convex mirror. Find the image height.
- A second object of unknown height is placed at a different location such that image heights are  $h_{\text{concave}} = -7.0$  cm and  $h_{\text{convex}} = 1.0$  cm when the hemisphere is used as a concave and convex mirror, respectively. What is the height of the second object?

# INNOVATIVE LIKE YOU.

If you're hoping for a truly modern education, one where you're encouraged to speak your mind and to think long-term, both when it comes to your own future and the future of the planet. Then the University of Gothenburg is the place for you.

Study a Master's programme in Gothenburg, Sweden | [www.gu.se/education](http://www.gu.se/education)



Click on the ad to read more

**Problem 4.30:** Two of the largest telescopes on Earth are Keck I & II on the summit of Mauna Kea on Hawaii (W. M. Keck Observatory). The telescopes are identical with a 10-m diameter.

- Ignore disturbances due to the Earth atmosphere. What is the resolving power of these telescopes? Assume visible light with wavelength  $\lambda = 550$  nm (green).
- You use this telescope to look for the features on the Moon. What is the size of the smallest object that you can see?

Some *useful* and *not-so-useful* information:

Length	Value
Elevation of Mauna Kea [above sea]	4208 m
Radius of Earth	$6.38 \times 10^3$ km
Radius of Moon	$1.74 \times 10^3$ km
Distance Earth - Moon	$3.84 \times 10^5$ km
Distance Earth - Sun	$1.496 \times 10^8$ km

**Problem 4.31:** The Doppler effect applies to all waves, including electromagnetic waves with the speed of light replacing the speed of sound. Astronomers observe the light emitted by a star, and notice that the Balmer line  $\lambda_0 = 656$  nm (corresponding to the  $n = 3 \rightarrow n = 2$  transition) is “red shifted” to  $\lambda = 660$  nm.

- Is the star moving towards or away from the Earth [assume that the Earth is at rest]?
- Calculate the speed of the star.

**Problem 4.32:** The rooms in a hotel are 4.2-m wide, and are staggered on the left (rooms #1, #3, #5,...) and right (rooms #2, #4, #6,...) of a 3.8-m wide hallway. The door openings are 1.2 m, and are in the middle of the rooms.

Use  $v = 343$  m/s for the speed of sound in air. Assume that sound emerging from a room can be treated as plane wave, and ignore (multiple) reflections of sound in the hallway.

- What is the range of wavelength that can leave one room and enter the room “diagonally across” the hallway, for example from room #1 to room #2.
- What musical tones can be heard “diagonally across” the hallway?

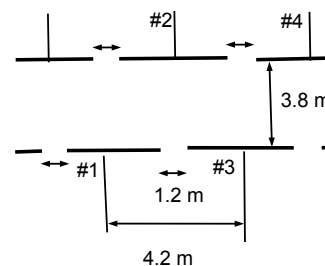

Tone	$A_3$	$C_4$	$D_4$	$G_4$	$A_4$	$C_5$	$D_5$	$G_4$
Frequency [Hz]	220	261.6	293.7	392.0	440.0	523.3	587.3	784.0

- The architect wants to prevent musical tones higher than  $G_4$  from traveling across the hallway. How does she change the floor plan?

**Problem 4.33:** A bucket with diameter  $D = 54$  cm is partially filled with water. The depth of the water is 24 cm. Harry carries the water-filled bucket. He walks and generates standing surface waves in the bucket. Assume that the displacement of water is greatest at the bucket wall. Treat the bucket as a one-dimensional container.

- Sketch the surface water wave across the bucket.
- Find the frequency of the standing surface waves.
- Make reasonable assumptions and estimate how fast Harry is walking.

**Problem 4.34:** Two converging lenses have focal lengths  $f_1 = 4.0$  cm and  $f_2 = 7.0$  cm, respectively. The object with height  $h_o = 4$  cm is placed infinitely far from lens #1.

- Lens #2 is placed the distance  $\Delta = 10.0$  cm behind lens #1. Find the location of the final image; is the final image real or virtual?
- Lens #2 is now moved to the distance  $\Delta = 12.0$  cm behind lens #1. Find the location of the final image; is the final image real or virtual?
- Draw the ray diagram for the case when lens #2 is  $\Delta = 11.1$  cm behind lens #1 (note that  $\Delta \gtrsim f_1 + f_2$ ). Where is the final image? What is the total magnification? Is the image real or virtual?
- The configuration in part **c**) is used in *Opera glasses*. What lenses do you use to build an opera glass where the objective (lens #1) and eye piece (lens #2) are separated by the distance  $\Delta = 12.0$  cm and magnifies 3.5-times.

**Problem 4.35:** Harry's retina is 2.1 cm behind the lens of his eyes. The power of the lens in his eyes is 52.5 diopters and 48.5 diopters when the lens is under tension and fully relaxed, respectively.

- Calculate Harry's far- and nearpoint. Is Harry far- or nearsighted?
- Harry complains about his vision and goes to the optometrist. What prescription does he need if he wears eyeglasses that are 2.0-cm from his eyes?
- Harry wears his eyeglasses and looks at an object that is 50.0 cm away from his eyes. What is the power of the lens in his eyes?

**Problem 4.36:** A rope has length  $l = 2.1$  m and mass  $m = 57$  g. The rope hangs from the ceiling, and a block with mass  $M = 3.7$  kg is attached at the bottom. Assume that the tension in the rope is determined by the weight of the block and the weight of the rope can be ignored. Use  $\rho_{\text{water}} = 1000$  kg/m<sup>3</sup> for the density of water.

- The rope is hit at the bottom, and a pulse travels upwards. What is the time for the pulse to reach the end of the rope at the top.
- The block near the bottom is completely immersed in water. The time for the pulse to travel the length of the rope is  $t' = 6.1 \times 10^{-2}$  s. Find the average density of the hanging block.

**Problem 4.37:** An electronic device produces the frequency  $f_{\text{device}} = 440$  Hz; it is hidden inside a tennis ball. We drop the tennis ball in a well that is 17.3-m deep. You hear the frequency as the ball drops to the bottom of the well and then rebounds completely inelastically and returns to the original height. Use  $v = 343$  m/s for the speed of sound.

- Describe the time dependence of the observed frequency, and draw a sketch of the graph for the observed frequency vs. the time.
- What is the highest and lowest frequency that you hear.
- You drop the tennis ball at time  $t = 0$ . When do you hear the frequency  $f' = 450$  Hz?

**Problem 4.38:** Seven rowboats are secured on two landing stages separated by the distance  $\Delta = 8.0$  m, as shown. The rowboats are separated by the distance 2.2 m. The landing area is protected by a wall at the distance  $L = 20$  m from the land. The wall has an opening of width  $D = 2.5$  m.

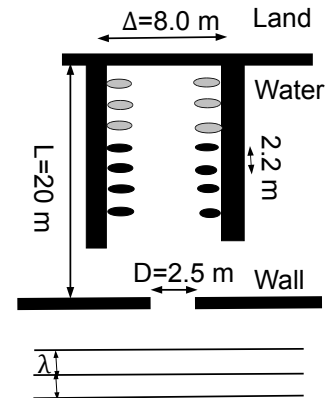

Ignore (multiple) reflection(s) of water waves.

- A surface wave hits the wall and enters the landing area. The three rowboats closest to land (in light gray) move *up-and-down*, while the remaining four rowboats on each side are stationary. Find the wavelength of the surface wave!
- The period of the oscillatory motion of the rowboats is 0.4 s. What is the speed of the surface wave?
- For what period of the oscillatory motion of the surface wave are all rowboats moving *up-and-down*?

**Problem 4.39:** A *convex* mirror has focal length  $f = -4.0$  cm. An object is 5.0 cm tall and is placed in front of the mirror. The image is upright and 2.0 cm tall.

- Draw the appropriate rays to find the location of the image.
- Find the image distance algebraically.
- Draw the appropriate ray diagram to find the location of the object.
- Find the object distance algebraically.

**Problem 4.40:** Harry and Emmy are both nearsighted. Harry's prescription is -2.5 diopters, Emmy's is -1.75 diopters. Both wear eyeglasses that are 2.0-cm from their eyes.

- What are the farpoints of Harry and Emmy?
- Harry and Emmy accidentally switch their eyeglasses. What is the farthest object that they can see clearly when they wear the "wrong" eyeglasses? *Explain your result!*



Linköping University –  
innovative, highly ranked,  
European

Interested in Computer Science? Kick-start your career  
with an English-taught master's degree.

→ Click here!







## 5: MODERN PHYSICS

**Problem 5.1:** If a photon travels in an electric field [usually produced by a nucleus, such as  $^{12}\text{C}$ ], it can spontaneously disintegrate into an electron and a positron which is the “anti-particle” of the electron. Both electron and positron have mass  $m = 9.11 \times 10^{-31}$  kg. This process is called *pair production*.

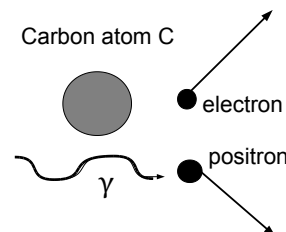

- Calculate the smallest possible photon frequency that produces pair production by assuming that both electron and positron are at rest.
- What is the recoil velocity of  $^{12}\text{C}$  as a result of pair production?

**Problem 5.2:** The length of a  $\text{C} = \text{C}$  bond is  $a = 0.139 \text{ nm} = 1.39 \times 10^{-10} \text{ m}$ . A dye-molecule consists of a backbone of six  $\text{C} = \text{C}$  bonds. We use the “particle-in-a-box” model to explain the light emitted by the dye-molecule.

- The electron is in the “first-harmonic state.” What is momentum and energy of the (valence-) electron?
- Find the wavelength of the photon necessary to excite the electron to first excited state? Is this within the visible range [400-700 nm]?

**Problem 5.3:** Neutrons are contained in a “bottle” kept at the temperature  $T = 1200 \text{ K}$ . Use  $m = 1 \text{ u}$  for the mass of a neutron.

- What is the energy [in eV] and momentum of the neutrons as they escape through small hole?
- The neutrons are traveling towards a copper lattice that acts as a diffraction grating. The lattice constant of the Cu lattice is  $b = 0.361 \text{ nm}$ . Find the angle  $\theta$  [away from the forward direction], where the first order diffraction peak is found!

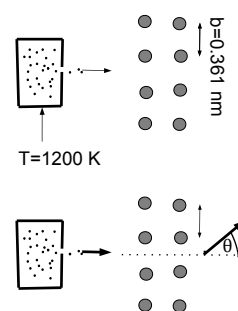

**Problem 5.4:** A metal plate is irradiated with light of variable wavelengths.

- The longest wavelength that can be used to eject electrons from the metal is  $\lambda_{\text{max}} = 540 \text{ nm}$ . Find the workfunction of the metal. Give your result in unit of eV.
- If visible light ( $380 \text{ nm} < \lambda < 750 \text{ nm}$ ) is used in the experiment, what is the speed of the fastest photo electron that can be produced?

**Problem 5.5:** A 1,000 Megawatt nuclear power plant produces nuclear “waste” including about 0.5 kg of plutonium each day. Atomic mass of plutonium  $m_{\text{Pu}} = 244 \text{ u}$ .

- The half life of plutonium is 24,360 years. Calculate the activity of 0.5 kg of plutonium.
- How long does it take for the activity to decrease to  $5.0 \times 10^7 \text{ Bq}$ ?

**Problem 5.6:** The (valence) electron in a dye-molecule is described by the *particle-in-a-box* model. The length of the box is a multiple of a C = C bond with length  $d_0 = 154 \text{ pm} = 0.154 \text{ nm}$ .

a) An electron undergoes a transition from  $n_i = 5$  to  $n_f = 2$  and emits light in the UV-vis range with a wavelength  $\lambda = 95.4 \text{ nm}$ . What is the number of C = C bonds in the backbone of the dye molecule?

b) Vibrations cause the length of the dye molecule to increase and decrease by 5%. What is the change in the wavelength of the emitted light when the electron undergoes the  $n_i = 5$  to  $n_f = 2$  transition?

**Problem 5.7:** In a simplified description, “blackbody” radiation are photons in thermal equilibrium, i.e., photons at thermal energies  $E_\gamma = k_B T$ , where  $T$  is the temperature and  $k_B$  is the Boltzmann constant.

a) What is the frequency and wavelength given off by the human body? In what range is the wavelength of the photon? Use  $37^\circ\text{C}$  [ $98.7^\circ\text{F}$ ] for body temperature.

b) Microwave radiation with wavelength  $\lambda = 5.3 \text{ mm}$  is observed by radiotelescopes when they are aimed in any direction. Assume that the origin of the photon is blackbody radiation. What is the temperature of the source of the radiation?

**Problem 5.8:** Neutrons are useful because they probe vibrations in solids and macromolecules (for example, high density lipoproteins HDL) during scattering processes.

a) Many neutron reactors produce ‘thermal neutrons.’ Find the wavelength of thermal neutrons (at room temperature  $T = 25^\circ\text{C}$ )!

b) The scattered thermal neutron has wavelength  $\lambda' = 0.165 \text{ nm}$ . Find the energy transferred to the solid/macromolecule during the scattering process.

**Problem 5.9:** The *Shroud of Turin* shows a remarkable negative imprint that is believed by some to be the imprint of Jesus including crucifixion wounds. The shroud first surfaced in the 14th century. Use that the half-time for carbon is  $T_{1/2} = 5730 \text{ yrs}$ . The natural activity of 1-g carbon from living samples is  $A_0 = 0.23 \text{ Bq}$ .

a) Small samples of cloth were taken and 1-g carbon samples produced. What activity would you expect based on the fact that Jesus lived 2000 years ago.

b) The observed activity of the sample from the shroud is  $A = 0.21 \text{ Bq}$ . How many years ago was the cloth produced?

c) What can you conclude regarding the historical origin of the shroud? (*Open-ended question*).

**Problem 5.10:** Electrons in a metal can be described by the “free-electron model:” the electrons are waves with wavelength  $2a < \lambda < \infty$  where  $a = 0.361 \text{ nm}$  is the lattice spacing between ions in the metal.

a) Find the maximum momentum  $p_{\text{max}}$ . What is the corresponding velocity of the electron (so-called *Fermi velocity*)?

b) Find the maximum energy  $E_{\text{max}}$ . What is the corresponding temperature?

**Problem 5.11:** “Sun bed” in tanning salons emit UVB radiation with wavelength  $\lambda = 320$  nm.

- Calculate the energy and momentum of one photon of UVB light.
- The intensity of UVB light is  $S = 0.09$  mW/(cm)<sup>2</sup>. Calculate how many photons hit a single skin cell during a 30 minute tanning session. Assume that the cross sectional area of a skin cell is  $5 \mu\text{m} \times 5 \mu\text{m}$ .

**Problem 5.12:** The electron in a hydrogen atom makes a transition from the state  $n = 4$  to the state  $n = 2$ .

- Determine the wavelength of the photon created in the process.
- Assuming that the hydrogen atom was initially at rest, determine the recoil speed of the hydrogen atom when this photon is emitted.

**Problem 5.13:** In the  $\beta^-$ -process, a neutron (n) decays into a proton (p), electron (e), and an (anti-) neutrino ( $\bar{\nu}_e$ ):  $n \rightarrow p + e + \bar{\nu}_e$ . A recent (2014) experiment has established an upper bound for the neutrino rest energy  $E_\nu < 0.3 - 0.9$  eV. On Earth, the biggest source of neutrinos are the thermonuclear reaction inside the Sun. It is estimated that the 3 million-billion solar neutrinos through every square meter. Assume that neutrinos travel at the speed of light. What is the upper limit for the mass density (i.e., mass per unit volume) of the neutrino gas near the Earth surface?

**STUDY FOR YOUR MASTER'S DEGREE  
IN THE CRADLE OF SWEDISH ENGINEERING**

Chalmers University of Technology conducts research and education in engineering and natural sciences, architecture, technology-related mathematical sciences and nautical sciences. Behind all that Chalmers accomplishes, the aim persists for contributing to a sustainable future – both nationally and globally.

Visit us on [Chalmers.se](http://Chalmers.se) or **Next Stop Chalmers** on facebook.

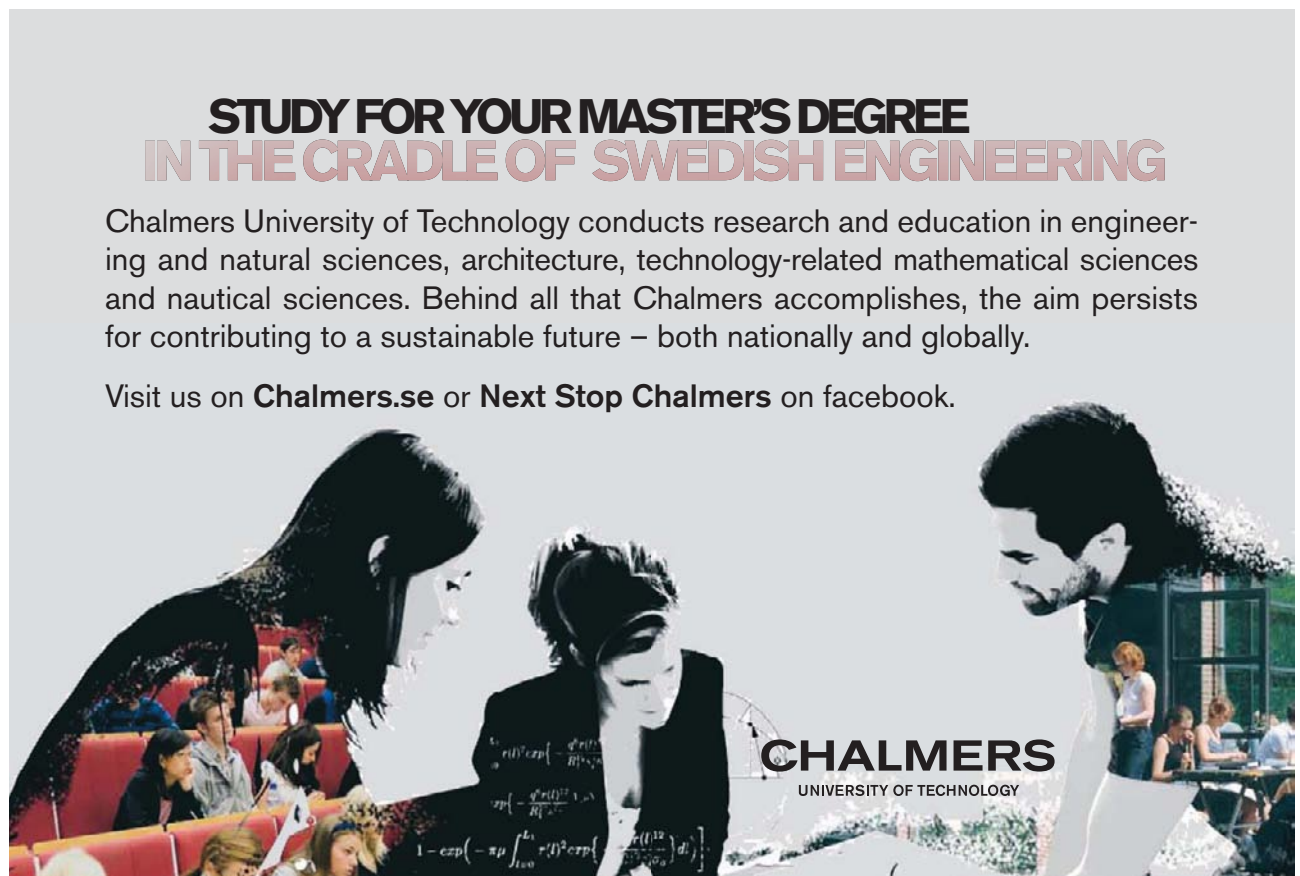

**CHALMERS**  
UNIVERSITY OF TECHNOLOGY



Click on the ad to read more

**Problem 5.14:** The absorbed dose  $D$  is defined as the absorbed energy per unit mass:  $D = E/m$ . The SI unit of dose is gray,  $1\text{Gy} = 1\text{ J/kg}$ . If humans are exposed to a dose  $D = 4\text{Gy}$ , 50% of the exposed population would be expected to die within 60 days [so called *50% lethal dose*]. A tank contains 80 liters of water. What is the increase in the temperature if the tank is exposed to a dose of 80 Gy?

**Problem 5.15:** Calculate the binding energy of the deuteron  ${}^2\text{D}$ .

**Problem 5.16:** In a simple model, the charge of the electron can “feel” its own electric field. It can be shown that that this self-interaction gives rise to an electron “self energy,”

$$\text{EPE}_{\text{self}} = \frac{ke^2}{a},$$

where  $a$  is the radius of the electron.

a) Assume the mass of the electron has purely electrostatic origin; this defines the so-called classical electron radius  $a$ . Calculate  $a$ .

b) What is the photon wavelength that would be necessary to “see” the size of the electron. Compare the photon wavelength to the Compton wavelength of the electron.

**Problem 5.17:** You want to study details of a biological specimen as small as 2.0 nm. The specimen is 5 cm in front of some type of lens with fixed aperture (opening) 4.0 mm.

a) What is the wavelength you need to see the desired details?

b) You use an *light microscope*. What is the frequency of the light? Can you see the electromagnetic wave with your naked eye? What is the energy of photons? *Convert to eV!*

c) You use an *electron microscope*. What is the speed of the electrons that would allow you to see the desired details? What is the kinetic energy of the electrons? *Convert to eV!*

**Problem 5.18:** In spectroscopy, a conventional unit for frequency is the number of wavelengths in one centimeter. The usual symbol is  $\tilde{\nu}$  so that  $[\tilde{\nu}] = \text{cm}^{-1}$ . This unit is called “kayser.”

a) What is the conversion factor from hertz to kayser?

b) One very strong infrared band of  $\text{H}_2\text{O}$  vapor has wavenumber  $\tilde{\nu} = 1595\text{ cm}^{-1}$ . What is the energy of the emitted photon?

**Problem 5.19:** Photons are particles traveling at the speed of light and thus have zero rest mass. However, an effective inertial mass of the photon may be defined via the relativistic energy mass equivalence,  $m_{\gamma,\text{eff}} = E_{\gamma}/c^2$ . A photon corresponding to yellow-line of sodium  $\lambda = 589\text{ nm}$  is emitted from a laser on the ground and shot to the top of the 541-m tall *Freedom Tower*.

a) What is the effective inertial mass of the photon?

b) What is the change in the energy of the photon as it climbs near the top?

c) What is the wavelength of the photon when it is near the top? Is the light red- or blue-shifted?

**Problem 5.20:** *Phonons* are quantized vibrations of the crystal lattice; they have properties similar to *photons*, in particular they both have zero mass. The wavelength of the vibrations is a multiple of the lattice constant  $a$ . Useful constant: lattice constant  $a = 3.61 \text{ \AA}$  and speed of sound  $c = 4800 \text{ m/s}$ .

- a) Find the energy and momentum of a phonon for a copper crystal when  $\lambda = 20 a$ .
- b) Compare the phonon energy to thermal energies. Are phonons important for properties of copper at room temperature? (*Open-ended question*).

 **MÄLARDALEN UNIVERSITY**  
SWEDEN

**WELCOME TO  
OUR WORLD  
OF TEACHING!**  
INNOVATION, FLAT HIERARCHIES  
AND OPEN-MINDED PROFESSORS

**STUDY IN SWEDEN -  
CLOSE COLLABORATION  
WITH FUTURE EMPLOYERS**  
MÄLARDALEN UNIVERSITY COLLABORATES WITH  
MANY EMPLOYERS SUCH AS ABB, VOLVO AND  
ERICSSON

**TAKE THE  
RIGHT TRACK**  
GIVE YOUR CAREER A HEADSTART AT MÄLARDALEN UNIVERSITY  
[www.mdh.se](http://www.mdh.se)

**DEBAJYOTI NAG**  
SWEDEN, AND PARTICULARLY  
MDH, HAS A VERY IMPRES-  
SIVE REPUTATION IN THE FIELD  
OF EMBEDDED SYSTEMS RE-  
SEARCH, AND THE COURSE  
DESIGN IS VERY CLOSE TO THE  
INDUSTRY REQUIREMENTS.  
HE'LL TELL YOU ALL ABOUT IT AND  
ANSWER YOUR QUESTIONS AT  
[MDUSTUDENT.COM](http://MDUSTUDENT.COM)

## HINTS

Reference to sections in U. Zurcher, *Algebra-Based College Physics I & II* (Bookboon, 2014) are given in square brackets, e.g., [1.1].

**Problem 1.1:** Treat the landing of the robber on carts as an *inelastic* collision [7.2]; find the forces from impulse-momentum theorem [7.1].

**Problem 1.2:** Use the conservation of linear momentum [7.1] to find the velocity of the cart and the conservation of mechanical energy [6.2] to find the initial angle  $\theta_0$ . The displacement of the cart follows from the center-of-mass coordinate [7.1].

**Problem 1.3:** Find the vector components of the two routes; the total displacement follows adding components [1.2].

**Problem 1.4:** The tennis ball is described by projectile motion [3]; find the time when the ball is caught from the horizontal displacement.

**Problem 1.5:** Find the speed of the brick right before hitting the ground from free fall [2.4] or conservation of energy [6.2]. find the “ground reaction force” from the impulse-momentum theorem [7.1].

**Problem 1.6:** Use the work-kinetic energy theorem [6.1].

**Problem 1.7:** Find the initial speed of the ball from kinematics equation for free fall [2.4]. Use  $v_{\text{ave}} = (v_0 + v_f)/2$  for the average velocity for motion with constant acceleration.

**Problem 1.8:** Apply Newton’s second law for both blocks [4.2]; the magnitude of the acceleration of the two blocks is the same.

**Problem 1.9:** Apply conditions of mechanical equilibrium to the pole [8.2]; choose the contact of the pole with the incline as the axis of rotation.

**Problem 1.10:** Use the work-kinetic energy theorem for rotation [8.3] to find the angular acceleration, and then use rotational kinematics equations [8.1].

**Problem 1.11:** Treat the block as a mathematical pendulum [9.2]; find the speed of the block along the vertical from conservation of mechanical energy [6.2]; the block undergoes circular motion [5].

**Problem 1.12:** Find the speed at the bottom from conservation of mechanical energy [6.2] and the “sticking” of the two blocks as an *inelastic* collision.

**Problem 1.13:** Find vector components and add the components [1.2].

**Problem 1.14:** The football is described by projectile motion [3]; the minimum speed is equal to the (constant) horizontal component of the velocity vector.

**Problem 1.15:** The runners can be described by motion with constant velocity [2.2].

**Problem 1.16:** Apply the kinematics equation for motion in one dimensions [2.2 & 2.3]; the closest distance between Emmy and Harry determines Emmy’s velocity.

**Problem 1.17:** First treat the two blocks as the ‘system’ and apply the conservation of mechanical energy [6.2]; then treat the block  $m_1$  as the ‘system’ and apply the work-kinetic energy theorem [6.1].

**Problem 1.18:** Apply Newton’s second laws separately for the three blocks [4.1]; the three blocks have the same acceleration.

**Problem 1.19:** The raindrop undergoes uniform circular motion [5]. The centripetal acceleration is directed along the horizontal direction.

**Problem 1.20:** Consider the Earth at rest and assume that the Moon orbits the Earth in uniform circular motion [8.1].

**Problem 1.21:** The board is in mechanical equilibrium [8.2]. Choose the center of the board as axis of rotation.

**Problem 1.22:** The ball is in projectile motion [3]. The ball in the person's hand corresponds to the 'peak' of the trajectory.

**Problem 1.23:** The no-slip condition relates the angular speed to the linear speed  $\omega = v/r$ , and the angular acceleration to the linear acceleration  $\alpha = a/r$  [8.1]. The total (translational and rotational) kinetic energy of the solid sphere is  $\text{KE} = (7/10)mv^2$  [8.3]. Find the linear acceleration from kinematics equations [2.3].

**Problem 1.24:** Use the conservation of energy for the sum of kinetic energy of the bob, gravitational potential energy, and elastic energy of the spring [6.2 & 9.1]. The bob is in circular motion.

**Problem 1.25:** Harry and Emmy travel at constant velocities (in opposite direction) [2.2].

**Problem 1.26:** Apply Newton's second law for both the wedge and the box [4.2]. The net force on the block and the wedge [and thus their accelerations] are directed along the horizontal. Choose the  $x$ - and  $y$ -axis along the horizontal and vertical, respectively.

**Problem 1.27:** The total linear momentum of the two blocks is always constant [7.1]. The sum of kinetic energy of the two blocks is not constant: the difference is not constant during the collision when the spring is compressed [6.1 & 9.3].

**Problem 1.28:** The motion of the ball undergoes simple harmonic motion. Identify the initial position of the ball with the turning point and the position at the bottom of the ball as the equilibrium position. The maximum speed at the equilibrium is determined by the amplitude and angular frequency [9.2].

**Problem 1.29:** The board is in mechanical equilibrium [8.2]. Choose the support as the axis of rotation. The torque produced by the weight of the board is the same in both situations.

**Problem 1.30:** Treat the ejection of water as an *inelastic* collision for the squid *plus* water system [7.2]; then consider the squid as the system and find the force on the squid from the impulse-momentum theorem [7.1].

**Problem 1.31:** Use the conservation of energy for the spring-block system [9.1] and find the friction force from the work-kinetic energy theorem [6.1].

**Problem 1.32:** Choose a fixed coordinate system; the center of mass is constant [7.1]. First find the combined mass of Emmy and the boat.

**Problem 1.33:** The block undergoes simple harmonic motion so that the block comes to a temporary stop at the turning point [9.1]. Energy is conserved for harmonic motion [9.3], and treat the clay hitting the block as an *inelastic* collision [7.2].

**Problem 1.34:** Use the conservation of energy to find the speed near the top [6.2]; include the rotational kinetic energy of the wheel using the no-slip condition  $\omega = v/r$  [8.1].

**Problem 1.35:** Find the linear acceleration and rotational acceleration [8.1]. Find the net force along the incline from the linear acceleration [4.1] and the static friction force from the angular acceleration [8.3].

**Problem 1.36:** The climber is in mechanical equilibrium [8.2]. Choose the contact between feet and the wall as the axis of rotation.

**Problem 1.37:** Angular momentum is conserved during the sommersault [8.3]; the rotational kinetic energy changes due to the work done by the person's muscles [considered as an *external* force].

**Problem 1.38:** The projectile is in free fall [2.4].

**Problem 1.39:** The acceleration of the blocks are determined by Newton's second law [4.2].

The rope connecting the blocks have different tensions to the left and right of pulley. The difference between the tensions produces a net torque on the pulley [8.3].

**Problem 1.40:** The plank is in mechanical equilibrium. Choose the lower end of the plank sitting on the ground as the axis of rotation [8.2].

**Problem 1.41:** The board is in mechanical equilibrium [8.2]. The spring forces are the same (different) when the block sits at (off) the center of the board [9.3].

**Problem 1.42:** Mechanical energy is conserved when the diver is in free fall [6.2]. Use the work-kinetic energy theorem to find the force exerted by the water on the diver [6.1].

**Problem 1.43:** The block undergoes motion in one dimension; find the average velocity (speed) from the total displacement (total distance) [2.1 & 2.2]. Use the definition of the period of a harmonic motion [9].

**Problem 1.44:** The wooden board is in mechanical equilibrium [8.2]. Choose the point of contact between the board and the leg as the axis of rotation.

**Problem 1.45:** Use the work-kinetic energy theorem to find the tension in the rope [8.3].

**Problem 1.46:** Emmy travels at constant velocities from A to B and from B to C [2.2].

**Problem 1.47:** The projectile is in free fall [2.4].

**Problem 1.48:** The #2 pencil undergoes rotational motion around the fixed tip. Note that there is translational motion of the pencil. Use the conservation of energy to find the angular speed [8.3].

**Problem 1.49:** The balls are in free fall [2.4]; when the red ball is in Harry's ball, neither of the other balls are at the highest point.



UPPSALA  
UNIVERSITET

## Develop the tools we need for Life Science Masters Degree in Bioinformatics

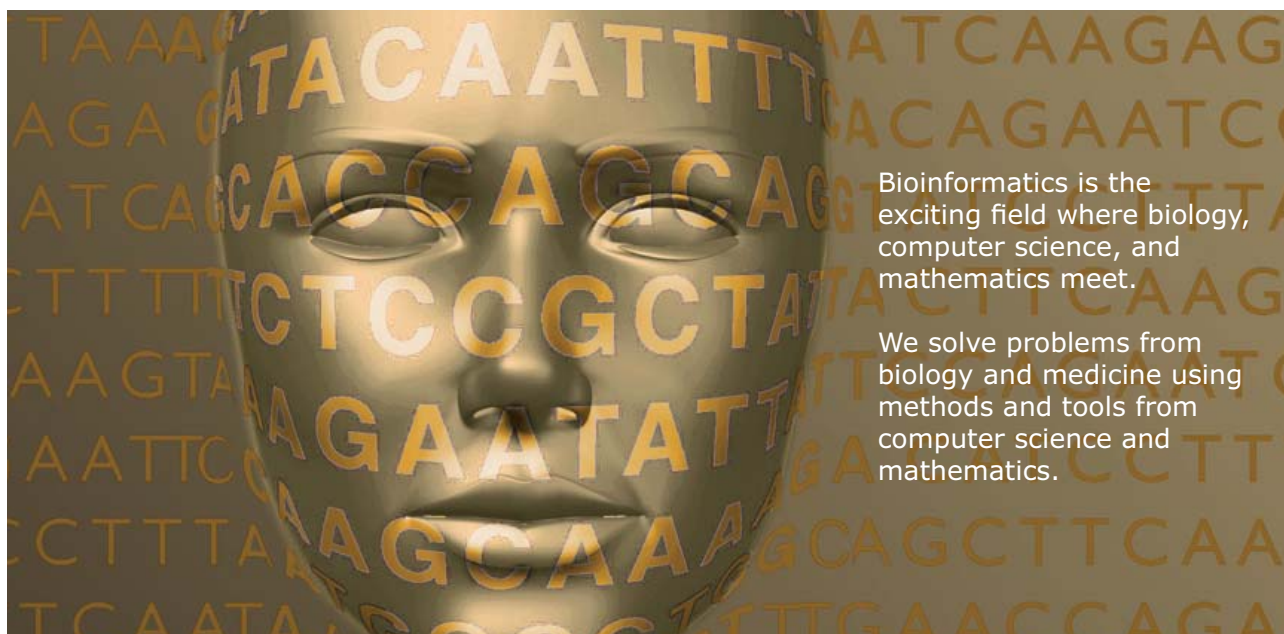

Bioinformatics is the exciting field where biology, computer science, and mathematics meet.

We solve problems from biology and medicine using methods and tools from computer science and mathematics.

Read more about this and our other international masters degree programmes at [www.uu.se/master](http://www.uu.se/master)





**Problem 1.50:** The vector sum of the weight and the two tension is zero. Use components to add vectors.

**Problem 1.51:** The bob is in circular motion so that the speed follows from the centripetal acceleration [5]. The net force follows from the impulse-momentum theorem [7.1].

**Problem 1.52:** Use the impulse-momentum theorem to analyze the ‘collision’ of the egg with the ground. The “ground reaction force” does work on the egg, while the package is compressed [6.1].

**Problem 1.53:** Treat the two blocks as the system and use the conservation of energy [6.2]. Then consider the block  $m_1$  as the system, and use the work-kinetic energy theorem to find the tension in the rope [6.1].

**Problem 1.54:** Apply Newton’s second law for linear motion [4.2] and rotation [8.3].

**Problem 1.55:** The maximum speed is determined by the amplitude and the period [9.2]. The momentum in horizontal direction is conserved when the clay sticks to the block [7.2].

**Problem 1.56:** The box is in mechanical equilibrium [8.2]; choose the front leg as the axis of rotation.

**Problem 1.57:** The linear and angular speed are related since the Yo-Yo does not slip [8.1]. Energy is conserved when the Yo-Yo falls [8.3]; find the tension in the rope from Newton’s second law for rotation [8.3].

**Problem 1.58:** The Earth surface is the turning point and the center of the Earth is the equilibrium position of the harmonic motion [9.1]; the acceleration due to gravity  $g$  is equal to the maximum acceleration [9.2].

**Problem 1.59:** Find the the impulse from the net force acting on the block, and then use the impulse- momentum theorem [7.1]. The bullet burying into the block is described as an inelastic collision [7.2].

**Problem 1.60:** The blocks are in uniform circular motion [5].

**Problem 1.61:** The box is in mechanical equilibrium [8.2]; the linear acceleration of the box along the horizontal direction is due to the static friction force.

**Problem 1.62:** The satellite is in uniform circular motion [5].

**Problem 1.63:** Treat the squirting of water as an inelastic collision [8.3]. Show that the squirting the gun  $n$  times [each time with mass  $m$ ] yields the same speed of Harry as squirting the gun only once but with total mass  $n \cdot m$ .

**Problem 1.64:** The ball is in projectile motion [3]; the top of the tower is the peak of the trajectory.

**Problem 1.65:** Consider the wheel and the block as the system and find the speed from the conservation of energy [8.3]. The torque follows from the work-rotational kinetic energy theorem [8.3].

**Problem 1.66:** Linear momentum is conserved for any collision [elastic or inelastic] [7.2]

**Problem 1.67:** Use Newton’s second law for the blocks separately [4.2].

**Problem 1.68:** The two blocks are in uniform circular motion [5]; both blocks have the same period. The distortion of the ball follows from the work-kinetic energy theorem [6.1].

**Problem 1.69:** Find the speed of the ball from the projectile motion [3]; and the time of impact from the impulse-momentum theorem.

**Problem 1.70:** The ball is in projectile motion [3]; at the peak, the ball “turns around.”

**Problem 2.1:** Find the average specific heat from the energy balance  $Q^\uparrow = Q^\downarrow$ . Write two equations (for the total mass and the average specific heat) to find the two unknowns, namely the mass of water and cellulose in the apple.

**Problem 2.2:** The work done by the weight changes the internal energy of the gas [12.4]; the pressure difference between the compartments holds up the weight [12.3].

**Problem 2.3:** Find the acceleration of the coin from kinematics equation [2.3]. Since the buoyant force is known [10.1], find the mass [and thus density] of the coin from Newton's second law [4.2].

**Problem 2.4:** Use the definition of pressure and the expression of hydrostatic pressure [10.1].

**Problem 2.5:** The flow speed changes due to the changes in the cross-sectional area [10.2]; a change in the flow speed induces a pressure difference.

**Problem 2.6:** The lower air pressure inside the pipette [10.1] is produced by the air flow across the pipette [10.2].

**Problem 2.7:** The floating block is in mechanical equilibrium [4.2]; when the block is submerged below the waterline, the increase in the buoyant force can be described in terms of a linear restoring force [9.3].

**Problem 2.8:** Consider the heat balance: heat is given off by the condensing steam and heat is absorbed by the water [12.2].

**Problem 2.9:** The number of moles follows from the ideal gas law [12.3]; water molecules are expelled due to the hydrostatic pressure [10.1].

**Problem 2.10:** The temperature of the air changes due to the added heat [12.1].

**Problem 2.11:** In a space heater, the dissipated heat is converted into heat; calculate the mass of air per minute that can be heated [12.4]. Assume maximum efficiency [Carnot] for the heat pump, and assume that the extracted heat from the cold ambient is "free" [12.4].

**Problem 2.12:** The buoyant force is determined by the total volume when the buoy is completely submerged; when the buoy swims the buoyant force is equal to the weight [10.1].

**Problem 2.13:** Use the ideal gas law to find the number of air molecules inside the balloon at ambient temperature and the number of expelled air molecules due to the increase in temperature [12.3]. Because the volume of the balloon is fixed, the buoyant force does not change [10.1].

**Problem 2.14:** Use the ideal gas law to calculate the number of air molecules in the two compartments [12.3]; the total internal energy is constant [12.4].

**Problem 2.15:** When ice melts, the center of mass is lowered so that the weight of the block of ice is doing work [6.1]; this work is converted into heat necessary for melting the ice [12.1 & 12.4].

**Problem 2.16:** The heat given off by the water is absorbed by the air [12.1]; use the ideal gas law to find the number of air molecules [12.3].

**Problem 2.17:** When the block is submerged below/above the water line, the net force is linear to the vertical displacement of the block [9.3 & 10.1]. Use the analogy with harmonic motion of the spring-block system [10.3].

**Problem 2.18:** The pressure difference between above and below the wing generates an upward force equal to the weight of the plane [10.2].

**Problem 2.19:** The gauge pressure is equal to the pressure difference between the inside and outside of the tire [10.1].

**Problem 2.20:** Calculate the probabilities for the various velocity intervals. For the root-mean-square average: first calculate the square of the velocities, then the average, and finally the square root. The average kinetic energy of molecules is determined by the absolute temperature [12.3].

**Problem 2.21:** Find the net force on the balloon from the buoyant force, weight of the hot air and the the load [10.1]. Use kinematics equations [2.3] to find the time to reach the top of the tower.

**Problem 2.22:** Use the table that the ratio is constant  $\Delta h/h = -\Delta t/\tau$ , where  $\tau$  is the time constant of exponential decay. The water level inside the bucket decreases because water flows through the horizontal pipe.

**Problem 2.23:** Write Newton's second law in the form  $F_{\text{net}} = m\Delta v/\Delta t$  [4.1] to show that  $\Delta v/\Delta t = (v_{\infty} - v)/\tau$ , where  $v_{\infty}$  is the terminal speed and  $\tau$  is the time constant of exponential time dependence. The buoyant force must be included [10.1].

**Problem 2.24:** Oxygen can be treated as an ideal gas [12.3] if the ambient (total) air pressure is replaced by the partial pressure of oxygen.

**Problem 2.25:** For the heat pump, the dissipated heat is used to heat the room. For the heat pump, the heat removed from the ambient air is "free" [12.4].

**Problem 2.26:** Process is isobaric for  $1 \rightarrow 2$ ; adiabatic for  $2 \rightarrow 3$ , and isochoric for  $3 \rightarrow 1$ . Use the first law to calculate the heat added/removed for each part [12.4].

**Problem 2.27:** Use the definition of entropy in terms of the added/removed heat and the temperature [12.4].

**Problem 2.28:**  $V = \text{const}$  for  $B \rightarrow C$  and  $C \rightarrow A$ ,  $P = \text{const}$  for  $A \rightarrow B$ , and  $T = \text{const}$  for  $C \rightarrow D$ . Use the first law to calculate the heat added/removed for each part [12.4].

**Problem 2.29:** When the rods are connected in parallel: the temperature difference is the same and the heat flux is the sum of the heat flux through each rod. When the rods are connected in series: the heat flux through the rods are the same - this condition determines the temperature of the point, where the rods are connected [12.1].

**Problem 2.30:** Use the equations for projectile motion to find the speed of water leaving the hose [3], which, in turn, determines the volume flow [10.2].



**Nido**

**Luxurious accommodation**

**Central zone 1 & 2 locations**

**Meet hundreds of international students**

**BOOK NOW and get a £100 voucher from voucherexpress**

**Nido Student Living - London**

**Visit [www.NidoStudentLiving.com/Bookboon](http://www.NidoStudentLiving.com/Bookboon) for more info.**

**+44 (0)20 3102 1060**



**Problem 3.1:** The direction of the Coulomb forces between the ions and the electron is determined by the geometry of the NaCl molecule and the location of the electron [13.1].

**Problem 3.2:** The center-of-mass (CoM) motion is conserved in the collision. The Coulomb force between the ions is “internal” and does *not* affect the motion of the CoM [7.1].

**Problem 3.3:** The directions of the Coulomb forces between the ions and the electron are determined by the geometry of the water molecule and the location of the electron [13.1].

**Problem 3.4:** The Coulomb force between the two ions is attractive [13.1]; the bond force balances the Coulomb force [13.1] and the electric force in the external electric field (if present) [13.2]. The increase in the bond force is described as an elastic force [9.3].

**Problem 3.5:** The dust particle is in free fall along the vertical [2.4]; the particle undergoes motion with constant acceleration along the horizontal [2.3]. The motion along the horizontal and vertical are independent of each other [2.4].

**Problem 3.6:** The electrostatic potential is the algebraic sum of the contribution of the two charges [13.3]. The electric field then follows from the vector sum of the electric fields produced by the two charges [13.2].

**Problem 3.7:** The current in a  $LC$ -circuit corresponds to the velocity of the block in the spring-block system. The magnetic and electric energies corresponds to the kinetic and potential energies, respectively [15.2 & 9.3].

**Problem 3.8:** First find the magnitude of the magnetic field; the direction of the magnetic field is then determined by a right-hand-rule [15.1].

**Problem 3.9:** The circuit is described by three currents [14.1]. The resistors cannot be replaced by an equivalent resistor.

**Problem 3.10:** Charged particles travel undeflected when the electric [13.2] and magnetic forces [15.1] cancel out each other. The strengths of the electric and magnetic fields determine the electric and magnetic energy densities, respectively [13.4 & 15.2].

**Problem 3.11:** The magnetic force on the charged particle acts along the radius, i.e., the magnetic force is the centripetal force [15.1].

**Problem 3.12:** The charge producing the electric field lies along the line defined by the electric field vector [13.2].

**Problem 3.13:** Simplify the circuit stepwise [14.1] by combining resistors connected in series and parallel.

**Problem 3.14:** The magnetic field at the point  $P$  is the vector sum of the the magnetic fields produced by the two wires [15.1].

**Problem 3.15:** The charge and current in the  $LC$ -circuit correspond to the coordinate and velocity of the block in the spring-block system [15.2 & 9.3]; the inductance corresponds to the mass  $L \sim m$  and the capacitance corresponds to the reciprocal spring constant  $C \sim 1/k$ . The  $LC$ -circuit is at a turning point when the capacitor is fully charged.

**Problem 3.16:** First calculate the magnitudes of the magnetic fields produced by the two thin wires, and then use a right-hand-rule to determine the direction [15.1]. Find the vector components of the magnetic fields [1.2].

**Problem 3.17:** The electric field is uniform inside the capacitor [13.2].

**Problem 3.18:** The magnetic field at  $P$  is determined by the current through the wire and the shortest distance between the wire and the point  $P$  [15.1]; the shortest distance is determined along a line *perpendicular* to the wire.

**Problem 3.19:** The electrostatic potential is the (algebraic) sum of the potentials produced by the two ions [13.3]. Use the conservation of energy to find the speed of the electron as it travels [6.2].

**Problem 3.20:** The vector sum of the weight and the Coulomb force are balanced by the spring force [4.2]. Find first the location of the charge on the ground and then the electric charge.

**Problem 3.21:** Only the  $4\ \Omega$  and  $6\ \Omega$  resistors form a series pair and no resistors can be treated as in parallel. The circuit is characterized by three currents [14.1].

**Problem 3.22:** Determine the force on the rod from the RHR [15.1]. Since the rod is parallel to the capacitor, the induced *EMF* across the rod determines the charge on the capacitor [15.2 & 14.1]. Energy is ‘lost’ due to the energy dissipated in the circuit.

**Problem 3.23:** The force on the charged particle is due to the magnetic force and a component of the tension in the string [5 & 15.1].

**Problem 3.24:** For motion with constant acceleration, the average velocity can be written in terms of the initial and final velocities  $v_{\text{ave}} = (v_i + v_f)/2$  [2.3]. The charge on the capacitor is determined by the potential difference [13.2].

**Problem 3.25:** The electric field produced by a single charge is in radial direction [13.2]; the total electric field is obtained by vector addition [1.2].

**Problem 3.26:** The forces on the hanging charge  $Q$  are the weight, the tension, and the Coulomb force from the other charge  $q$ . The charge  $q$  is moved very slowly so that the charge  $Q$  is always in (almost) mechanical equilibrium [4.2].

**Problem 3.27:** The direction of the magnetic field produced by the current is in the  $(x, y)$ -plane [15.1].

**Problem 3.28:** The circle is an equipotential line for the charge  $q_1$  at the origin [13.3].

**Problem 3.29:** The charge on the capacitor is fixed when the battery is removed from the capacitor. The electrostatic potential energy stored in the capacitor changes when the dielectric material is removed [13.3]. The average force follows from the work [6.1].

**Problem 3.30:** The proton is in uniform circular motion [5]; the equivalent current is given by the ratio of the elementary charge and the period.

**Problem 3.31:** The electron “feels” the electrostatic potential from the oxygen and the two hydrogen ions [13.3]. The sum of kinetic energy and electrostatic potential energy is conserved [6.2].

**Problem 3.32:** The potassium ion undergoes projectile [3] and uniform circular [4] motion when an electric and a magnetic field is present, respectively. The force on the potassium ion is determined by Newton’s second law [4.1], which then yields the strength of the electric [13.2] and magnetic fields [15.1].

**Problem 3.33:** The oil drop is in mechanical equilibrium [4.2]. Because the oil drop is negatively charged, the electric force on the drop and the electric field are in opposite direction [13.2]. The electric field inside the capacitor is proportional to the electric charges on the capacitor plates.

**Problem 3.34:** The charge on the capacitor decays exponentially; the time constant is determined by the capacitance and the resistance [14.2]. The dissipated energy can be calculated from the loss of the stored electrostatic potential energy [13.3].

**Problem 3.35:** The electric potential ‘felt’ by the electron is produced by the potassium and sodium ions [13.3]. The total energy of the electron is conserved: the change of the kinetic energy of the electron is due to the change in the electrostatic potential energy [13.3].

**Problem 3.36:** The “protein drifts” implies that its velocity is constant and the net force is zero [2.2 & 4.2]. The relevant forces are the electric force and the drag (friction) [13.2].

**Problem 3.37:** Calculate the number of electrons flowing through the cross-section per second, and assume that each copper atom occupies the volume of a sphere; use the lattice constant as the radius of the sphere. Calculate the drift speed from the volume flow rate [10.2]. In thermal equilibrium, the kinetic energy of electrons is determined by the absolute temperature [12.3].

**Problem 3.38:** The rod glides down with constant constant velocity so that the net force is zero [4.1]; the forces along the incline are a component of the weight of the rod and the magnetic force. The direction of the current follows from the right-hand rule [15.1]. The induced *EMF* is equal to the voltage drop across the resistor.

**Problem 3.39:** Use the work-kinetic energy theorem to calculate the potential difference between the capacitor plates [6.1 & 13.3]. The motion of the oxygen ion is analogous to projectile motion: the acceleration is zero along the *y*-axis,  $a_y = 0$ , and is non-zero along the *x*-axis,  $a_x \neq 0$  [3].

**Problem 3.40:** The induced voltage in the circuit is produced by the change in the magnetic flux [15.2].

Brain power

By 2020, wind could provide one-tenth of our planet's electricity needs. Already today, SKF's innovative know-how is crucial to running a large proportion of the world's wind turbines.

Up to 25 % of the generating costs relate to maintenance. These can be reduced dramatically thanks to our systems for on-line condition monitoring and automatic lubrication. We help make it more economical to create cleaner, cheaper energy out of thin air.

By sharing our experience, expertise, and creativity, industries can boost performance beyond expectations.

Therefore we need the best employees who can meet this challenge!

The Power of Knowledge Engineering

Plug into The Power of Knowledge Engineering.  
Visit us at [www.skf.com/knowledge](http://www.skf.com/knowledge)

**SKF**

**Problem 4.1:** The wave speed and the wavelength determines the frequency [11.2]. There is only a single frequency in this system; that is, the period of the wave motion is identical to period of the harmonic motion of each bead [9.2].

**Problem 4.2:** The ultrasound pulses travel with constant velocity [2.2]. The time to travel from the transducer to the “wall” is identical to the travel time from the “wall” to the transducer.

**Problem 4.3:** The length of the organ pipe and the boundary condition (i.e., closed or open) determines the wavelength [11.5].

**Problem 4.4:** The condition that “consecutive wave crests hit their legs at the same time” is a condition for the wavelength. The depth of the water determines the wave speed [11.1].

**Problem 4.5:** The mass of a bead and the separation determines mass per unit length, which then determines the wave speed [11.2]. Each bead undergoes simple harmonic motion so that the acceleration is determined by the frequency and amplitude [9.2].

**Problem 4.6:** The frequency of the insect corresponds to the first harmonic of the standing wave along the silk thread [11.5].

**Problem 4.7:** The inverse of the time interval is equal to the frequency; the source of the surface water waves (namely the wind) is stationary, while the observer (namely the boat) moves [11.3].

**Problem 4.8:** The wave speed  $v = \lambda f$  determines the speed of crests [and troughs] of the wave [11.1].

**Problem 4.9:** The energy density of the electromagnetic radiation is determined by intensity [16]; air can be treated as ideal gas [12.3].

**Problem 4.10:** This is a ‘two-lens’ problem: (1) the prescription eye glasses and (2) the lens in her eyes. A real image is formed at the retina [17.2].

**Problem 4.11:** The frequency of the light is independent of the material. The wavelength changes because the wave speed changes [16].

**Problem 4.12:** The shortest (longest) wavelength corresponds to the highest (lowest) frequency [11].

**Problem 4.13:** The possibility to “see” an object is given by the resolving power [18].

**Problem 4.14:** The blackboard is the object; the image formed by her correction eye glasses is at her farpoint [17.2]. When a farsighted person sees object “fuzzy,” the image by the lens in the eye is not formed on the retina.

**Problem 4.15:** First use geometry to find the angle of the refracted ray in the glass [17].

**Problem 4.16:** The image is formed between the object and the lens [17.2].

**Problem 4.17:** The image is always formed on the retina [17.2].

**Problem 4.18:** Because the virtual image is smaller than the object, a convex mirror is used [17.2].

**Problem 4.19:** The possibility to “see” an object is determined by the resolving power [18].

**Problem 4.20:** Because the enlarged virtual image is to the *left*, a concave mirror is inside the “black box” [17.2].

**Problem 4.21:** The intensity of sunlight is determined by the strength of the electric and magnetic fields [16]. Intensity is defined as power/area.

**Problem 4.22:** Virtual images are upright [17.1].

**Problem 4.23:** “Normal ordering” lines means that the diffraction angle of the red line in order  $n$  is less than the diffraction angle of the violet line in the next order  $n + 1$  [18].

**Problem 4.24:** The object distances are determined by the requirement that the images are formed at the far- and nearpoints [17.2].

**Problem 4.25:** Express the  $\sin \theta_1$  and  $\sin \theta_2$  as a function of the  $x$ -coordinate where the lifeguard enters the water. Use a numerical software package [e.g., *Excel* - Part of the Office Suite (Microsoft Corp, Redmond, WA)] to solve the mathematical condition implied by Snells law [17.2].

**Problem 4.26:** Use the method of ray tracing [17.2].

**Problem 4.27:** The intensity determines the energy density of electromagnetic waves [16], which, in turn, determines the magnitude of the electric field [13.4].

**Problem 4.28:** Use ray tracing [17.3]; the intermediate image is real.

**Problem 4.29:** The second object is at an unknown distance from the mirror. Use the mirror equation twice to find an equation for the image distances [17.1].

**Problem 4.30:** The possibility to “see” an object is determined by the resolving power [18].

**Problem 4.31:** The Doppler shift for frequencies applies to all waves, including electromagnetic waves [11.3]. Keep (at least) four significant figures in intermediate calculations.

**Problem 4.32:** Sound is diffracted at the doors [11.6]; the geometry of the rooms determines the diffraction angle.

**Problem 4.33:** The standing waves inside the bucket corresponds to the first harmonic [11.5]. Walking is the source of the water waves; the frequency of the water wave and the frequency associated with walking are the same [11.1].

**Problem 4.34:** The lens equation simplifies because the object is infinitely far away [17.2].

**Problem 4.35:** Normal vision corresponds to a farpoint at infinity, and a nearpoint at the “standard” reading distance 25 cm. If the object is at an intermediate distance, the power of the lens in the eye is found by solving a two-lens problem [17.2].

**Problem 4.36:** The speed of the pulse is determined by the wave speed, which, in turn, depends on the tension in the rope [11.2].

**Problem 4.37:** The device inside the tennis ball is the source of sound and the observer is stationary [11.3].

**Problem 4.38:** The surface water wave is diffracted at the opening. Row boats within the diffraction cone move up-and-down, while the others are at rest [11.6].

**Problem 4.39:** The image is virtual and behind the mirror [17.1].

**Problem 4.40:** The correction eyeglasses form (virtual) images at the farpoint [17.2].

**Problem 5.1:** The photon energy is converted into the energy associated with the rest masses of the electron and positron [19].

**Problem 5.2:** The electron is described by a standing wave [20.2].

**Problem 5.3:** The neutrons can be treated as an ideal gas [12.3]; the energy of the neutrons determines their wavelength. The diffraction of particle waves follows the same physical laws as those of any other wave [11.6].

**Problem 5.4:** The shortest wavelength of photons is produced when electrons are ejected with zero kinetic energy [20.1].

**Problem 5.5:** Express the half-life of plutonium in seconds [21].

**Problem 5.6:** The energy of the emitted photon determined by the difference of the electron as it makes the transition  $n_i = 5 \rightarrow n_f = 2$  [20.2]

**Problem 5.7:** The energy of particles in thermal equilibrium is proportional to the (absolute) temperature [12.3].

**Problem 5.8:** The neutron scattering can be described by an inelastic collision of the neutron with an (unknown) particle [7.2].

**Problem 5.9:** The activity decreases exponentially with time [21].



**Problem 5.10:** The smallest (largest) wavelength of the electron determines the largest (smallest) momentum [20.2].

**Problem 5.11:** The intensity can be written as the number of photons per area and time multiplied by the energy of one photon [20.1].

**Problem 5.12:** Initially the hydrogen is at rest. The total momentum is conserved during the emission of the photon, which can be modeled as collision [7.2].

**Problem 5.13:** Calculate the number density (number per cubic-meter) of neutrinos from the stated number of neutrinos crossing a square-meter and per second [10.2].

**Problem 5.14:** The absorbed heat and the absorbed dose are proportional to the mass of the sample.

**Problem 5.15:** A deuteron consists of a proton and a neutron [19].

**Problem 5.16:** The electrostatic potential energy of the electron is equal to the rest energy of the electron [19].

**Problem 5.17:** For any type of wave, the size of the sample must be of the order of the wavelength [18].

**Problem 5.18:** The frequency is inversely proportional to the wavelength [11.2].

**Problem 5.19:** For a photon with 'mass'  $m = E/c^2$ , the photon energy decreases as the mass gains gravitational potential energy [6.2].

**Problem 5.20:** Since phonons are massless particles, the momentum is given by  $p = h/\lambda$  and the energy is  $E = hf$  [20.1]



**GET A MASTER'S DEGREE IN UMEÅ!**

- modern campus • world class research • 32 000 students
- top class teachers • ranked nr 1 in Sweden by international students

**Master's programmes:**

- Architecture
- Industrial Design
- Science
- Engineering

Download brochure here!



**UMEÅ UNIVERSITY**  
FACULTY OF SCIENCE & TECHNOLOGY



## SOLUTIONS

**Problem 1.1:** Here we use “velocity,” “momentum” and “forces” to mean the components of the velocity, momentum, and forces parallel to the tracks. We treat the landing of the robber on a runaway cart as inelastic collisions: When he jumps to the slower cart, the conservation of linear momentum yields:

$$253 \text{ kg} \cdot 1.3 \frac{\text{m}}{\text{s}} + 82 \text{ kg} \cdot 3.2 \frac{\text{m}}{\text{s}} = (253 \text{ kg} + 82 \text{ kg}) \cdot v'_2,$$

so that the speed with him securely standing on the cart,

$$v'_2 = \frac{591.3 \text{ kg} \cdot \text{m/s}}{335 \text{ kg}} = 1.8 \frac{\text{m}}{\text{s}}.$$

We repeat for the landing back to the original (fast) cart:

$$253 \text{ kg} \cdot 3.2 \frac{\text{m}}{\text{s}} + 82 \text{ kg} \cdot 1.8 \frac{\text{m}}{\text{s}} = 335 \text{ kg} \cdot v''_1,$$

so that the velocity follows

$$v''_1 = \frac{957.2 \text{ kg m/s}}{335 \text{ kg}} = 2.9 \frac{\text{m}}{\text{s}}.$$

That is, the two jumps have resulted in an overall slow down of the fast cart. We calculate the force exerted on the carts from the change in momentum, or impulse,  $J = m\Delta v = F\Delta t$ . We then find the force exerted on the slow cart,

$$F_{\text{landing}}^{(1)} = \frac{m(v'_2 - v_1)}{\Delta t} = \frac{82 \text{ kg} \cdot (1.8 \text{ m/s} - 3.2 \text{ m/s})}{1.2 \text{ s}} = -96 \text{ N},$$

and the force exerted on the fast cart,

$$F_{\text{landing}}^{(2)} = \frac{m(v''_1 - v'_2)}{\Delta t} = \frac{82 \text{ kg} \cdot (2.9 \text{ m/s} - 1.8 \text{ m/s})}{1.2 \text{ s}} = 75 \text{ N},$$

We note that the forces are in opposite direction:  $F_{\text{landing}}^{(1)} < 0$  - the robber slides *forward* on the slower cart and the friction force on the cart is directed *backward*;  $F_{\text{landing}}^{(2)} > 0$  - the robber slides *backward* on the faster cart and the friction force on the cart is forward.

**Problem 1.2:** The momentum of the system [mass and cart] is zero:  $p_{\text{tot}} = 0$ . The conservation of momentum yields  $p_{\text{tot}} = 0 = mv + MV_{\text{cart}}$ , so that  $V_{\text{cart}} = -(m/M)v$ , or

$$V_{\text{cart}} = -\frac{1.2 \text{ kg}}{5.4 \text{ kg}} \cdot 1.8 \frac{\text{m}}{\text{s}} = -0.4 \frac{\text{m}}{\text{s}}.$$

The cart moves towards the *left*. In the vertical position, the system has only kinetic energy:  $E_{\text{mech}} = mv_{m,1}^2/2 + MV_{\text{cart}}^2/2$ , or

$$E_{\text{mech}} = \frac{1.2 \text{ kg}}{2} \left(1.8 \frac{\text{m}}{\text{s}}\right)^2 + \frac{5.4 \text{ kg}}{2} \left(0.4 \frac{\text{m}}{\text{s}}\right)^2 = 1.94 \text{ J} + 0.43 \text{ J} = 2.37 \text{ J}.$$

This is equal to the initial potential energy  $E_{\text{mech}} = mgh = mgL(1 - \cos \theta_0)$  so that  $\cos \theta_0 = 1 - E/mgL$ ,

$$\cos \theta_0 = 1 - \frac{2.37 \text{ J}}{1.2 \text{ kg} \cdot 9.8 \text{ m/s}^2 \cdot 0.86 \text{ m}} = 0.76,$$

and  $\theta_0 = 40.0^\circ$ . We use a coordinate system with  $x = 0$  at the original center of the cart. We find the horizontal displacement of the bob  $\delta x = -0.86 \text{ m} \cdot \sin 40^\circ = -0.55 \text{ m}$ . Since the CoM is fixed, we obtain  $m\delta x = (M + m)\Delta x$ , so that the displacement of the cart follows  $\Delta x = m/(m + M) \delta x$ ,

$$\Delta x = \frac{1.2 \text{ kg}}{1.2 \text{ kg} + 5.4 \text{ kg}} (-0.55 \text{ m}) = -0.1 \text{ m}.$$

The cart (as well as the bob) undergoes oscillatory motion. The amplitude of the motion is equal to the displacement of the cart  $A = |\Delta x| = 0.1 \text{ m}$ . Since  $V_{\text{cart}} = \omega A$ , the angular frequency follows  $\omega = V_{\text{cart}}/A$ , or

$$\omega = \frac{0.4 \text{ m/s}}{0.1 \text{ m}} = 4.0 \text{ s}^{-1},$$

so that  $T = 1.57 \text{ s}$ . Compare this period with that of the mathematical pendulum, i.e., in the limit  $M \gg m$ :  $T_{\text{math}} = 2\pi\sqrt{L/g} = 2\pi\sqrt{(0.86 \text{ m})/(9.8 \text{ m/s}^2)} = 1.86 \text{ s}$ .

**Problem 1.3:** We find the distance along route #1:  $d_1 = 6.5 \text{ km/h} \cdot 2.0 \text{ h} = 13.0 \text{ km}$ . The east-west and north-south components follow

$$\Delta x_1 = 13 \text{ km} \cdot \cos 38^\circ = 10.2 \text{ km} \quad \Delta y_1 = -13.0 \text{ km} \cdot \sin 38^\circ = -8.0 \text{ km}.$$

Since the skipper returns to the longitude at the start: the east-west component of route #2 is  $\Delta x_2 = -10.2 \text{ km}$ . The skipper stays on route #2 for the time  $t_2$ :  $-10.2 \text{ km} = -6.5 \text{ km/h} \cdot \cos 63^\circ \cdot t_2$ ; we solve for the time  $t_2$ ,

$$t_2 = \frac{10.2 \text{ km}}{6.5 \text{ km/h} \cdot \cos 63^\circ} = 3.5 \text{ h}.$$

The north-south component of route #2 follows  $\Delta y_2 = -6.5 \text{ km/h} \cdot \sin 63^\circ \cdot 3.5 \text{ h} = -20.3 \text{ km}$ . Thus, she crosses the W  $154^\circ$  longitude at the distance  $D$  from island B:

$$D = 45 \text{ km} - 8.0 \text{ km} - 20.3 \text{ km} = 16.7 \text{ km}.$$

In general, the condition  $\Delta x_1 = -\Delta x_2$  gives  $6.5 \text{ km/h} \cdot \cos 38^\circ \cdot t_1 = 6.5 \text{ km/h} \cdot \cos 63^\circ \cdot t_2$ . The speed  $6.5 \text{ km/h}$  drops out and we express  $t_2$  in terms of  $t_1$ :

$$t_2 = \frac{\cos 38^\circ}{\cos 63^\circ} t_1 = 1.74 t_1.$$

The condition that the skipper arrives on island B gives  $\Delta y = -45 \text{ km} = 6.5 \text{ km/h} \cdot \sin 38^\circ \cdot t_1 - 6.5 \text{ km/h} \cdot \sin 63^\circ \cdot t_2$ , or  $45 \text{ km} = 4.0 \text{ km/h} \cdot t_1 + 5.8 \text{ km/h} \cdot t_2$ , or

$$45 \text{ km} = \left( 4.0 \frac{\text{km}}{\text{h}} + 1.74 \cdot 5.8 \frac{\text{km}}{\text{h}} \right) \cdot t_1 = 14.1 \frac{\text{km}}{\text{h}} \cdot t_1.$$

We solve for the time  $t_1$  of the first leg:

$$t_1 = \frac{45 \text{ km}}{14.1 \text{ km/h}} = 3.2 \text{ h.}$$

**Problem 1.4:** We calculate the horizontal component of the velocity of the tennis ball:  $v_{0,x} = 25.0 \text{ m/s} \cdot \cos 35^\circ = 20.5 \text{ m/s}$ . Since  $\Delta x = v_{0,x} t_{\text{air}} = 57.0 \text{ m}$  is the ball's horizontal displacement, we find the time in air:  $t_{\text{air}} = \Delta x / v_{0,x}$

$$t_{\text{air}} = \frac{57.0 \text{ m}}{20.5 \text{ m/s}} = 2.8 \text{ s.}$$

The vertical component of the initial velocity is given by  $v_{0,y} = 25.0 \text{ m/s} \cdot \sin 35^\circ = 14.3 \text{ m/s}$ . This gives the height where the ball is caught  $h = y(t_{\text{air}}) = v_{0,y} t_{\text{air}} - gt_{\text{air}}^2 / 2$ :

$$\begin{aligned} h &= 14.3 \frac{\text{m}}{\text{s}} \cdot 2.8 \text{ s} - \frac{1}{2} \cdot 9.8 \frac{\text{m}}{\text{s}^2} \cdot (2.8 \text{ s})^2, \\ &= 40.2 \text{ m} - 37.9 \text{ m} = 2.3 \text{ m.} \end{aligned}$$

We find the vertical component of velocity of the ball at the time  $t_{\text{air}}$ :  $v_{y,\text{air}} = v_{0,y} - gt_{\text{air}}$ , or

$$v_{y,\text{air}} = 14.3 \frac{\text{m}}{\text{s}} - 9.8 \frac{\text{m}}{\text{s}^2} \cdot 2.8 \text{ s} = -12.9 \frac{\text{m}}{\text{s}}.$$

The speed of the ball is equal to the magnitude of the velocity vector:  $v = \sqrt{v_{0,x}^2 + v_{y,\text{air}}^2}$ ,

$$v = \sqrt{\left(20.5 \frac{\text{m}}{\text{s}}\right)^2 + \left(-12.9 \frac{\text{m}}{\text{s}}\right)^2} = 24.3 \frac{\text{m}}{\text{s}}.$$



*Scholarships*

**Lnu.se**

## Open your mind to new opportunities

With 31,000 students, Linnaeus University is one of the larger universities in Sweden. We are a modern university, known for our strong international profile. Every year more than 1,600 international students from all over the world choose to enjoy the friendly atmosphere and active student life at Linnaeus University. Welcome to join us!

**Linnæus University**  
Sweden

**Bachelor programmes in**  
Business & Economics | Computer Science/IT | Design | Mathematics

**Master programmes in**  
Business & Economics | Behavioural Sciences | Computer Science/IT | Cultural Studies & Social Sciences | Design | Mathematics | Natural Sciences | Technology & Engineering

**Summer Academy courses**



**Problem 1.5:** We use the conservation of energy to calculate the speed of the brick before it hits the ground:  $mgh = mv_g^2/2$ . We solve for the speed:  $v_g = \sqrt{2gh}$ ,

$$v_g = \sqrt{2 \cdot 9.8 \frac{\text{m}}{\text{s}^2} \cdot 8.0 \text{ m}} = 12.5 \frac{\text{m}}{\text{s}}.$$

For the collision with the ground: the initial velocity is  $v_i = v_g = 12.5 \text{ m/s}$  and the final velocity is  $v_f = 0$ . The initial and final momentum of the brick follows  $p_i = 0.3 \text{ kg} \cdot 12.5 \text{ m/s} = 3.75 \text{ kg} \cdot \text{m/s}$  and  $p_f = 0$ . We find the brick's change in momentum, or impulse,  $J = \Delta p = p_f - p_i = -p_i$ ,

$$J = -3.75 \frac{\text{kg m}}{\text{s}}.$$

Since the bricks comes to a full stop in the time  $\Delta t = 0.012 \text{ s}$ , the average total force force is given by:  $F_{\text{ave}} = \Delta p / \Delta t$ ,

$$F_{\text{ave}} = \frac{-3.75 \text{ kg m/s}}{0.012 \text{ s}} = -312.5 \text{ N}.$$

Here, the negative sign means that the average force is directed *upwards*. Since the weight of the brick  $W = mg = 0.3 \text{ kg} \cdot 9.8 \text{ m/s}^2 = 2.9 \text{ N}$  points downwards, the normal force [or "ground reaction force"] follows

$$F_N = -312.5 \text{ N} - 2.9 \text{ N} = -315.4 \text{ N}.$$

**Problem 1.6:** The initial kinetic energy of the golf ball is zero:  $\text{KE}_i = 0$ . We find the final kinetic energy:  $\text{KE}_f = mv^2/2$ ,

$$\text{KE}_f = \frac{1}{2} 0.045 \text{ kg} \cdot \left(19.0 \frac{\text{m}}{\text{s}}\right)^2 = 8.1 \text{ J}.$$

We use the work-kinetic energy theorem to calculate the work done on the golf ball:  $W = \Delta \text{KE} = \text{KE}_f$ ,

$$W = 8.1 \text{ J}.$$

This work is done while the golf ball is compressed by the distance  $s = 1.2 \times 10^{-3} \text{ m}$ . Since  $W = F_{\text{ave}} \cdot s$ , with  $s = 1.2 \times 10^{-3} \text{ m}$ . We solve for the (average) force exerted by the club on the ball:  $F_{\text{ave}} = W/s$ ,

$$F_{\text{ave}} = \frac{8.1 \text{ J}}{1.2 \times 10^{-3} \text{ m}} = 6.8 \text{ kN}.$$

In flight, work is done by the gravitational force [weight of the ball], which we express in terms of the gravitational potential energy of the ball:  $W' = -\Delta \text{PE} = -\text{PE}_f = -mgy_f$  so that

$$W' = -0.045 \text{ kg} \cdot 9.8 \frac{\text{m}}{\text{s}^2} \cdot 9.6 \text{ m} = -4.2 \text{ J}.$$

We use the work-kinetic energy theorem:  $W' = \Delta \text{KE}' = \text{KE}'_f - \text{KE}'_i$  with  $\text{KE}'_i = \text{KE}_f$ . We solve for the ball's kinetic energy at the point  $P$ :  $\text{KE}'_f = \text{KE}'_i + W'$ ,

$$\text{KE}'_f = 8.2 \text{ J} + (-4.2 \text{ J}) = 4.0 \text{ J}.$$

Since  $\text{KE}'_f = mv_P^2/2$ , we find the speed of the ball at the point  $P$ :  $v_P = \sqrt{2\text{KE}'_f/m}$ ,

$$v_P = \sqrt{\frac{2 \cdot 4.0 \text{ J}}{0.045 \text{ kg}}} = 13.2 \frac{\text{m}}{\text{s}}.$$

Since  $\text{KE}'_f = mv_P^2/2$ , we find the speed of the ball at the point  $P$ :  $v_P = \sqrt{2\text{KE}'_f/m}$ ,

$$v_P = \sqrt{\frac{2 \cdot 4.0 \text{ J}}{0.045 \text{ kg}}} = 13.2 \frac{\text{m}}{\text{s}}.$$

**Problem 1.7:** The ball is in (vertical) free fall. When the ball at its highest point:  $v = 0$ . Since  $h = 15 \text{ m} - 1 \text{ m} = 14 \text{ m}$ , we find the displacement:  $\Delta y = h = (v_0^2 - v^2)/2g = v_0^2/2g$ . We thus find the initial speed:  $v_0 = \sqrt{2gh}$ ,

$$v_0 = \sqrt{2 \cdot 9.8 \frac{\text{m}}{\text{s}^2} \cdot 14.0 \text{ m}} = 16.6 \frac{\text{m}}{\text{s}}.$$

The vertical displacement is  $\Delta y = -1.0 \text{ m}$ . Since  $v_f^2 = v_0^2 - 2g\Delta y$ , we obtain

$$v_f^2 = \left(16.6 \frac{\text{m}}{\text{s}}\right)^2 + 2 \cdot 9.8 \frac{\text{m}}{\text{s}^2} \cdot 1.0 \text{ m} = 294.0 \left(\frac{\text{m}}{\text{s}}\right)^2.$$

Since the ball falls,  $v_f < 0$ , and we obtain

$$v_f = -17.2 \frac{\text{m}}{\text{s}}.$$

Since the acceleration is constant, the average velocity can be calculated from the initial and final velocities:  $v_{\text{ave}} = (v_0 + v_f)/2$ ,

$$v_{\text{ave}} = \frac{1}{2} \left[ 16.6 \frac{\text{m}}{\text{s}} + \left(-17.2 \frac{\text{m}}{\text{s}}\right) \right] = -0.3 \frac{\text{m}}{\text{s}}.$$

We write the average velocity in terms of the displacement  $\Delta y$  and the time  $t$ ,  $v_{\text{ave}} = \Delta y/t$ . We solve for the time  $t = \Delta y/v_{\text{ave}}$ ,

$$t = \frac{-1.0 \text{ m}}{-0.3 \text{ m/s}} = 3.3 \text{ s},$$

note that  $t > 0$ , as it should.

**Problem 1.8:** The forces on the hanging mass  $m_1$  are the weight  $W_1 = m_1g = 3.0 \text{ kg} \cdot 9.8 \text{ m/s}^2 = 29.4 \text{ N}$  and the tension in the string  $T$ . The force on the block  $m_2$  on the ground are the weight  $W_2 = m_2g = 5.0 \text{ kg} \cdot 9.8 \text{ m/s}^2 = 49.0 \text{ N}$ , the tension  $T$ , the normal force  $F_N$ , and the (kinetic) friction force  $f_k = \mu_k F_N$ . We draw the *free-body* diagrams for the two blocks. Newton's second law for the hanging block  $m_1$  yields

$$\sum F_y = 29.4 \text{ N} - T = 3.0 \text{ kg} \cdot a,$$

and Newton's second law for block on the ground  $m_2$ :

$$\begin{aligned}\sum F_x &= T - f_k = 5.0 \text{ kg} \cdot a, \\ \sum F_y &= F_N - 49.0 \text{ N} = 0.\end{aligned}$$

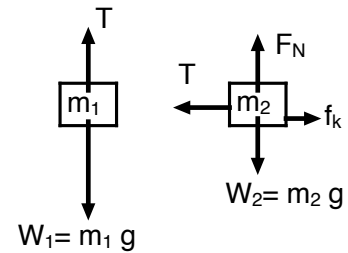

The normal force follows  $F_N = 49.0 \text{ N}$ . Then the friction force is given by  $f_k = 0.24 \cdot 49.0 \text{ N} = 11.8 \text{ N}$ . Inserted into Newton's second law for  $m_2$  along the horizontal  $T - 11.8 \text{ N} = 5.0 \text{ kg} \cdot a$  so that the tension in the string follows

$$T = 5.0 \text{ kg} \cdot a + 11.8 \text{ N}.$$

We now find from Newton's second law for  $m_1$ :  $29.4 \text{ N} - 5.0 \text{ kg} \cdot a + 11.8 \text{ N} = 3.0 \text{ kg} \cdot a$ , so that the (common) acceleration of the two blocks follows

$$a = \frac{29.4 \text{ N} - 11.8 \text{ N}}{5.0 \text{ kg} + 3.0 \text{ kg}} = 2.2 \frac{\text{m}}{\text{s}^2}.$$

Insert the acceleration  $a$  into the equation for the tension in the string:

$$T = 5.0 \text{ kg} \cdot 2.2 \frac{\text{m}}{\text{s}^2} + 11.8 \text{ N} = 22.8 \text{ N}.$$

It is instructive to solve this problem symbolically. The acceleration follows  $a/g = (m_1 - \mu_k m_2)/(m_1 + m_2)$ .

In the past four years we have drilled

# 89,000 km

That's more than **twice** around the world.

**Who are we?**  
We are the world's largest oilfield services company<sup>1</sup>. Working globally—often in remote and challenging locations—we invent, design, engineer, and apply technology to help our customers find and produce oil and gas safely.

**Who are we looking for?**  
Every year, we need thousands of graduates to begin dynamic careers in the following domains:

- Engineering, Research and Operations
- Geoscience and Pettechnical
- Commercial and Business

**What will you be?**

[careers.slb.com](http://careers.slb.com)

**Schlumberger**

<sup>1</sup>Based on Fortune 500 ranking 2011. Copyright © 2015 Schlumberger. All rights reserved.



**Problem 1.9:** We draw the free-body diagram for the pole. The forces are the weight  $W = 240 \text{ N}$  (downward), the tension  $T$  in the rope (horizontal) the normal force  $F_N$  (perpendicular to the incline) the static friction  $f_s$  (along the incline). We choose the  $x$ -axis along the horizontal direction and the  $y$ -axis along the vertical. We start from Newton's second law for the pole:

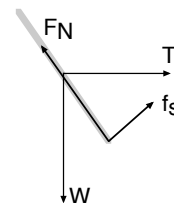

$$\begin{aligned}\sum F_x &= T + f_s \cos 30^\circ - F_N \sin 30^\circ = 0, \\ \sum F_y &= F_N \cos 30^\circ + f_s \sin 30^\circ - 240.0 \text{ N} = 0.\end{aligned}$$

We choose the point of contact between the pole and the incline as the axis of rotation; with this choice the normal force and the static friction do not contribute to the torque. Since  $240.0 \text{ N} \cdot 2.6 \text{ m} \cos 30^\circ = 540.0 \text{ Nm}$ . Since  $2.6 \text{ m} \cdot \sin 30^\circ = 1.3 \text{ m}$ , the torque follows

$$\sum \tau = -540.4 \text{ Nm} + T \cdot 1.3 \text{ m} = 0.$$

We solve for the tension,

$$T = \frac{540.4 \text{ Nm}}{1.3 \text{ m}} = 415.7 \text{ N}.$$

We use  $\sin 30^\circ = 1/2$  and  $\cos 30^\circ = \sqrt{3}/2$ , and find two equations for the normal force and static friction force:

$$\begin{aligned}\frac{\sqrt{3}}{2} f_s - \frac{1}{2} F_N &= -415.7 \text{ N}, \\ \frac{\sqrt{3}}{2} F_N + \frac{1}{2} f_s &= 240 \text{ N},\end{aligned}$$

so that  $f_s = 480 \text{ N} - \sqrt{3}F_N$ , and we get

$$\sqrt{3} [480 \text{ N} - \sqrt{3}F_N] - F_N = -831.4 \text{ N},$$

or  $4F_N = 1662 \text{ N}$ . We find the normal force  $F_N = 415.5 \text{ N}$ ; the static friction follows  $f_s = -239.7 \text{ N}$ . Here, the negative sign means that the direction of the static friction in the free-body diagram is incorrect; it should be in the opposite direction.

**Problem 1.10:** We find the magnitude of the torque on the disk produced by the tension  $\tau = Tr$ ,

$$\tau = 1.4 \text{ N} \cdot 0.4 \text{ m} = 0.56 \text{ Nm}.$$

Since the angular displacement is  $\Delta\theta = 2\pi \text{ rad}/4 = 1.57 \text{ rad}$ , the rotational work done by the torque follows  $W = \tau\Delta\theta$ ,

$$W = 0.56 \text{ Nm} \cdot 1.57 \text{ rad} = 0.88 \text{ J}.$$

We now use the work-kinetic energy for rotation. Since the disk is initially at rest,  $\omega_i = 0$ ,  $W = \Delta\text{KE} = I\omega_f^2/2$ . The angular speed follows  $\omega_f = \sqrt{2W/I}$ ,



$$\omega_f = \sqrt{\frac{2 \cdot 0.88 \text{ J}}{0.74 \text{ kg} \cdot \text{m}^2}} = 1.54 \frac{\text{rad}}{\text{s}}.$$

Newton's second law for rotation reads  $\tau = I\alpha$ . We solve for the angular acceleration  $\alpha = \tau/I$ ,

$$\alpha = \frac{0.56 \text{ Nm}}{0.74 \text{ kg m}^2} = 0.76 \frac{\text{rad}}{\text{s}^2}.$$

We find the elapsed time  $t$  from rotational kinematics  $\Delta\theta = \alpha t^2/2$  since  $\omega_i = 0$ . We find  $t = \sqrt{2\Delta\theta/\alpha}$ ,

$$t = \sqrt{\frac{2 \cdot 1.57 \text{ rad}}{0.76 \text{ rad/s}^2}} = 2.04 \text{ s}.$$

**Problem 1.11:** The initial position is the turning point and the vertical position is the equilibrium position for the mathematical pendulum. The period is given by  $T = 2\pi\sqrt{L/g}$  so that We find the period  $T$ :

$$T = 2\pi\sqrt{\frac{1.7 \text{ m}}{9.8 \text{ m/s}^2}} = 2.62 \text{ s}.$$

Thus, the time from the turning point to the equilibrium point is a quarter period  $t^* = T/4$ ,

$$t^* = \frac{2.62 \text{ s}}{4} = 0.65 \text{ s}.$$

Because the block is initially at rest, the mechanical energy is equal the initial potential energy:  $E_{\text{mech}} = \text{PE}_i = mgh$ ,

$$E_{\text{mech}} = 0.5 \text{ kg} \cdot 9.8 \frac{\text{m}}{\text{s}^2} \cdot 0.125 \text{ m} = 0.61 \text{ J}.$$

This potential energy is transformed into kinetic energy of the block at the vertical position:  $\text{KE} = 0.61 \text{ J} = mv_{\text{max}}^2/2$ . The maximum speed follows  $v_{\text{max}} = \sqrt{2 \cdot \text{KE}/m}$ ,

$$v_{\text{max}} = \sqrt{\frac{2 \cdot 0.61 \text{ J}}{0.5 \text{ kg}}} = 1.56 \frac{\text{m}}{\text{s}}.$$

When the block is at the vertical position, the forces acting on it are the tension  $T$  (up) and weight  $W = mg = 0.5 \text{ kg} \cdot 9.8 \text{ m/s}^2 = 4.9 \text{ N}$  (down). Since the block undergoes circular motion, the acceleration of the block in the vertical position is  $a_c = v_{\text{max}}^2/L$ ,

$$a_c = \frac{(1.56 \text{ m/s})^2}{1.7 \text{ m}} = 1.4 \frac{\text{m}}{\text{s}^2}.$$

We then find from Newton's second law for the block: circular motion  $T - 4.9 \text{ N} = 0.5 \text{ kg} \cdot 1.4 \text{ m/s}^2 = 0.7 \text{ N}$ . Thus, the tension in the string follows

$$T = 4.9 \text{ N} + 0.7 \text{ N} = 5.6 \text{ N}.$$

**Problem 1.12:** The mechanical energy of the block is constant as the object glides down the frictionless ramp. The conservation of energy yields  $PE_0 + KE_0 = PE_b + KE_b$ . Since the block is initially at rest  $KE = 0$  and  $PE_0 = mgh = 0.125 \text{ kg} \cdot 9.8 \text{ m/s}^2 \cdot 0.6 \text{ m} = 0.74 \text{ J}$ . At the bottom of the bowl  $PE_b = 0$  and  $KE_b = mv_b^2/2$ . Since  $KE_b = PE_0$ , the speed at the bottom of the ramp  $v_b$  follows  $v_b = \sqrt{2KE_b/m}$ ,

$$v_b = \sqrt{\frac{2 \cdot 0.74 \text{ J}}{0.125 \text{ kg}}} = 3.4 \frac{\text{m}}{\text{s}}.$$

(This is equal to  $v_b = \sqrt{2gh}$  - i.e., the speed at the bottom of the bowl is independent of the mass of object). The linear momentum is conserved during the (inelastic!) collision when the two objects collide  $mv_b = (2m)v'_b$ , so that  $v'_b = v_b/2$ ,

$$v'_b = \frac{3.4 \text{ m/s}}{2} = 1.7 \frac{\text{m}}{\text{s}}.$$

We use the conservation of mechanical energy to calculate the maximum height of the right side. The kinetic energy of the two block moving together:  $KE'_b = (2m)(v'_b)^2/2 = m(v'_b)^2$ ,

$$KE' = 0.125 \text{ kg} \left(1.7 \frac{\text{m}}{\text{s}}\right)^2 = 0.36 \text{ J}.$$

The kinetic energy is transformed into gravitational potential energy  $KE' = PE' = mgh'$  so that  $h' = KE'/2mg = (0.36 \text{ J})/(2 \cdot 0.125 \text{ kg} \cdot 9.8 \text{ m/s}^2) = 0.15 \text{ m}$ . It is easy to see that  $h' = h/4$ .

## Trust and responsibility

NNE and Pharmaplan have joined forces to create NNE Pharmaplan, the world's leading engineering and consultancy company focused entirely on the pharma and biotech industries.

Inés Aréizaga Esteva (Spain), 25 years old  
Education: Chemical Engineer

– You have to be proactive and open-minded as a newcomer and make it clear to your colleagues what you are able to cope. The pharmaceutical field is new to me. But busy as they are, most of my colleagues find the time to teach me, and they also trust me. Even though it was a bit hard at first, I can feel over time that I am beginning to be taken seriously and that my contribution is appreciated.



NNE Pharmaplan is the world's leading engineering and consultancy company focused entirely on the pharma and biotech industries. We employ more than 1500 people worldwide and offer global reach and local knowledge along with our all-encompassing list of services.  
[nnepharmaplan.com](http://nnepharmaplan.com)

nne pharmaplan®



**Problem 1.13:** We find the components of the vector  $\vec{B}$ :  $B_x = 6.4 \cos 38^\circ = 5.0$  and  $B_y = 6.4 \sin 38^\circ = 3.9$ . Then  $C_x = A_x + B_x$  and  $C_y = A_y + B_y$ ,

$$C_x = -1.2 + 5.0 = 3.8, \quad C_y = 2.7 + 3.9 = 6.6.$$

We find the magnitude  $|\vec{C}| = \sqrt{C_x^2 + C_y^2}$ ,

$$|\vec{C}| = \sqrt{(3.8)^2 + (6.6)^2} = 7.6$$

and its direction follows from  $\tan \theta_C = C_y/C_x = 6.6/3.8 = 1.74$ . We find

$$\theta_C = \tan^{-1} 1.74 = 60^\circ.$$

Since  $\sin 49^\circ = 0.75$  and  $\cos 49^\circ = 0.66$ , we write the  $x$  and  $y$  components of the vector  $\vec{E}$ :  $E_x = -1.2 + 0.57D$  and  $E_y = 2.7 + 0.82D$ . We find  $\tan 22^\circ = 0.4 = E_y/E_x$ , so that

$$0.4 = \frac{2.7 + 0.75D}{-1.2 + 0.66D}$$

A simple re-arrangement yields  $0.4(-1.2 + 0.66D) = 2.7 + 0.82D$ , or  $-0.48 + 0.16D = 2.7 + 0.75D$ . We find

$$D = \frac{2.7 + 0.5}{0.75 - 0.16} = 5.4$$

**Problems 1.14:** The football travels at the minimum speed when it is at the highest point [“peak” of the trajectory]. We identify the minimum speed with the horizontal component of the velocity vector,  $v_{\min} = v_{x,0}$ ,

$$v_{x,0} = 17.4 \frac{\text{m}}{\text{s}}.$$

Since the distance  $d = 52.8 \text{ m}$  is the horizontal displacement, we find  $d = v_{x,0}t_{\text{air}}$  so that time in air follows  $t_{\text{air}} = d/v_{x,0}$ , or

$$t_{\text{air}} = \frac{52.8 \text{ m}}{17.4 \text{ m/s}} = 3.03 \text{ s}.$$

The time to reach peak follows  $t_{\text{peak}} = t_{\text{air}}/2 = 1.52 \text{ s}$ . At the highest point, the vertical component of the instantaneous velocity vanishes,  $v_{y,\text{peak}} = 0 = v_{y,0} - gt_{\text{air}}$  so that  $v_{y,0} = gt_{\text{air}}$ ,

$$v_{y,0} = 9.8 \frac{\text{m}}{\text{s}^2} \cdot 1.52 \text{ s} = 14.9 \frac{\text{m}}{\text{s}}.$$

The launch speed follows  $v_0 = \sqrt{v_{x,0}^2 + v_{y,0}^2}$ ,

$$v_0 = \sqrt{\left(17.4 \frac{\text{m}}{\text{s}}\right)^2 + \left(14.9 \frac{\text{m}}{\text{s}}\right)^2} = 22.9 \frac{\text{m}}{\text{s}}.$$

The launch angle follows from  $\tan \theta_0 = v_{y,0}/v_{x,0} = (14.9 \text{ m/s})/(17.4 \text{ m/s}) = 0.86$  so that  $\theta_0 = 41^\circ$ . Here we calculate the maximum height  $H$  from  $v_{y,0}$ :  $v_{y,\text{peak}}^2 = 0 = v_{y,0}^2 - 2gH$  so that  $H = v_{y,0}^2/2g$ ,

$$H = \frac{(14.9 \text{ m/s})^2}{2 \cdot 9.8 \text{ m/s}^2} = 11.3 \text{ m}.$$

Alternatively, the height of the peak can be calculated from the time to reach the peak  $t_{\text{peak}}$  and the vertical component of the launch velocity  $v_{y,0}$ .

**Problem 1.15:** Since John runs at the speed  $v_J = 6.0 \text{ m/s}$ , we find the speed of Marcia:

$$v_M = 1.15 \cdot 6.0 \frac{\text{m}}{\text{s}} = 6.9 \frac{\text{m}}{\text{s}}.$$

We calculate the time for Marcia to complete the race:

$$t_M = \frac{100 \text{ m}}{6.9 \text{ m/s}} = 14.5 \text{ s}.$$

We find the position of John at that time (assume  $x = 0$  at the start):  $x_J = v_J t_M$

$$x_J = 6.0 \frac{\text{m}}{\text{s}} \cdot 14.5 \text{ s} = 87.0 \text{ m}.$$

Thus, Marcia beats John by the distance  $\Delta x = x_M - x_J = 100 \text{ m} - 87.0 \text{ m} = 13.0 \text{ m}$ .  
The time for John to complete the race:

$$t_J = \frac{100 \text{ m}}{6.0 \text{ m/s}} = 16.6 \text{ s}.$$

So Marcia beats John by the time  $\Delta t = t_J - t_M$ ,

$$\Delta t = 16.6 \text{ s} - 14.5 \text{ s} = 2.1 \text{ s}.$$

We repeat the reasoning for Rob and Susan. We use  $d = 100 \text{ m}$ . When Rob finishes the race, Susan is at the distance  $\Delta x' = 24.5 \text{ m}$  from the finish; he beats her by the time  $\Delta t' = 16.5 \text{ s}$ . It follows that the Susan's speed can be written  $v_S = \Delta x' / \Delta t'$ ,

$$v_S = \frac{24.5 \text{ m}}{16.5 \text{ s}} = 1.48 \frac{\text{m}}{\text{s}}.$$

We write the time difference in terms of their speeds:  $\Delta t' = t_S - t_R = d/v_S - d/v_R$

$$\Delta t' = \frac{d}{v_S} \left( 1 - \frac{v_S}{v_R} \right).$$

and the distance  $\Delta x'$  in terms of the time for Rob to complete the race  $t_R = d/v_R$ :  $\Delta x' = d - v_S t_R$ ,

$$\Delta x' = d \left( 1 - \frac{v_S}{v_R} \right).$$

Since  $\Delta x' / d = 1 - v_S / v_R$ , we find the ratio of velocities  $v_S / v_R = 1 - \Delta x' / d$ . We solve for the speed of Rob:  $v_R = v_S / (1 - \Delta x' / d)$ , or

$$v_R = \frac{1.48 \text{ m/s}}{1 - 24.5 \text{ m} / 100 \text{ m}} = 1.96 \frac{\text{m}}{\text{s}}.$$

**Problem 1.16:** The graph for Harry is a straight line, and that for Emmy is a parabola:

$$x_E(t) = \frac{1}{2} 0.23 \frac{\text{m}}{\text{s}^2} t^2,$$

$$x_H(t) = -63 \text{ m} + 4.7 \frac{\text{m}}{\text{s}} t$$

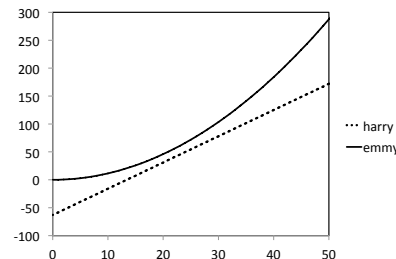

The time for Harry to reach the origin:  $t_1 = (63 \text{ m}) / (4.7 \text{ m/s}) = 13.4 \text{ s}$ . We find the position of Emmy at that time,

$$x_E(13.4 \text{ s}) = \frac{1}{2} 0.23 \frac{\text{m}}{\text{s}^2} \cdot (13.4 \text{ s})^2 = 20.6 \text{ m}.$$

That is, Emmy is 20.6 m ahead of Harry. Emmy runs twice as fast as Harry at some time  $t_2$ :  $v_E = 2 \cdot 4.7 \text{ m/s} = 9.4 \text{ m/s}$ . Since Emmy runs at a constant acceleration starting from rest, we find  $v_E = at_2$ ; we solve for the time  $t_2$ :  $t_2 = v_E/a$ ,

$$t_2 = \frac{9.4 \text{ m/s}}{0.23 \text{ m/s}^2} = 40.9 \text{ s}.$$

We find the positions of Harry and Emmy at the time  $t_E$ :

$$x_E(40.9 \text{ s}) = \frac{1}{2} 0.23 \frac{\text{m}}{\text{s}^2} \cdot (40.9 \text{ s})^2 = 192.3 \text{ m},$$

$$x_H(40.9 \text{ s}) = -63 \text{ m} + 4.7 \frac{\text{m}}{\text{s}} \cdot 40.9 \text{ s} = 129.2 \text{ m}.$$

We find the separation of Harry and Emmy:  $\Delta x = 192.3 \text{ m} - 129.2 \text{ m} = 63.1 \text{ m}$ . Harry gets closer to Emmy as long as  $v_E > v_H$ ; Harry then falls further behind when  $v_H < v_E$ . We conclude that the closest distance between Harry and Emmy occurs when Emmy runs at the speed of Harry,  $v_E = v_H$ . We now obtain  $v_E = 4.7 \text{ m/s} = at^*$  and solve for the time  $t^* = v_E/a$ :

$$t^* = \frac{4.7 \text{ m/s}}{0.23 \text{ m/s}^2} = 20.4 \text{ s}.$$

We find the position of Harry and Emmy:

$$x_E(20.4 \text{ s}) = \frac{1}{2} 0.23 \frac{\text{m}}{\text{s}^2} \cdot (20.4 \text{ s})^2 = 47.9 \text{ m}$$

$$x_H(20.4 \text{ s}) = -63 \text{ m} + 4.7 \frac{\text{m}}{\text{s}} \cdot 20.4 \text{ s} = 32.9 \text{ m}$$

The smallest separation between Harry and Emmy follows  $\Delta x_{\min} = 47.9 \text{ m} - 32.9 \text{ m} = 15.0 \text{ m}$ .

**Problem 1.17:** We consider the two blocks as the system. Because the two blocks are connected by a string, their speeds are the same. We choose a coordinate system with  $y = 0$  at the ground. Since  $y_{1,i} = y_{2,i} = 0.21 \text{ m}$ , we find the initial gravitational potential energy of the two blocks:

$$\text{PE}_i = 0.97 \text{ kg} \cdot 9.8 \frac{\text{m}}{\text{s}^2} \cdot 0.21 \text{ m} + 1.20 \text{ kg} \cdot 9.8 \frac{\text{m}}{\text{s}^2} \cdot 0.21 \text{ m} = 2.0 \text{ J} + 2.5 \text{ J} = 4.5 \text{ J}.$$

The block  $m_2$  hits the ground  $y_{2,f} = 0$  and the block  $m_1$  reaches  $y_{1,f} = 0.21 \text{ m} + 0.21 \text{ m} = 0.42 \text{ m}$ . The final potential energy follows

$$\text{PE}_f = 0.97 \text{ kg} \cdot 9.8 \frac{\text{m}}{\text{s}^2} \cdot 0.42 + 1.20 \text{ kg} \cdot 9.8 \frac{\text{m}}{\text{s}^2} \cdot 0 = 4.0 \text{ J} + 0 = 4.0 \text{ J}.$$

The initial kinetic energy of the the blocks is zero; when the block  $m_2$  hits the ground  $\text{KE}_f = (0.97 \text{ kg} + 1.20 \text{ kg})v_f^2/2$ . The conservation of energy gives  $\text{PE}_i = \text{PE}_f + \text{KE}_f$  so that  $\text{KE}_f = 4.5 \text{ J} - 4.0 \text{ J} = 0.5 \text{ J}$ . We use  $\text{KE}_f = (m_1 + m_2)v_f^2/2$  and solve for the final speed

$$v_f = \sqrt{\frac{2 \cdot 0.5 \text{ J}}{0.97 \text{ kg} + 1.20 \text{ kg}}} = 0.68 \frac{\text{m}}{\text{s}}.$$

We know consider only the block  $m_1$  as our system. We use the work kinetic energy theorem to find the total work done on block  $m_1$ :  $W = \Delta\text{KE}_1$ , or

$$W_{1,\text{total}} = \frac{0.97 \text{ kg}}{2} \left(0.68 \frac{\text{m}}{\text{s}}\right)^2 = 0.22 \text{ J}.$$

The total work is done by gravity [weight] and the tension. We find the work done by gravity is  $W_g = -\Delta\text{PE}_1 = -0.97 \text{ kg} \cdot 9.8 \text{ m/s}^2 \cdot 0.21 \text{ m} = -2.00 \text{ J}$ . Since  $W_{1,\text{total}} = W_T + W_g$ , we find the work done by the tension in the string:  $W_T = W_{\text{total}} - W_g$ ,

$$W_T = 0.22 \text{ J} - (-2.00 \text{ J}) = 2.22 \text{ J}.$$

The work  $W_T$  is done by the tension while the block  $m_1$  is lifted through the height  $h = 0.21 \text{ m}$ . Since  $W_T = Th$ , we find the tension  $T = W_T/h$ ,

$$T = \frac{2.22 \text{ J}}{0.21 \text{ m}} = 10.6 \text{ N}.$$

Of course, we can find the tension in the string by solving Newton's second law of motion.

**Problem 1.18:** The forces are the weights of the blocks, the normal forces exerted by the surface, the forces  $T_1$  and  $T_2$  in the rods, and the pull force  $F$ . We write Newton's second law for  $m_1$ :

$$\begin{aligned} \sum F_x &= T_1 = 3.2 \text{ kg} \cdot a, \\ \sum F_y &= F_{N,1} - 31.4 \text{ N} = 0, \end{aligned}$$

for  $m_2$ :

$$\begin{aligned} \sum F_x &= 39.0 \text{ N} - T_1 - T_2 = 7.4 \text{ kg} a, \\ \sum F_y &= F_{N,2} - 72.5 \text{ N} = 0, \end{aligned}$$

and for  $m_3$ :

$$\begin{aligned} \sum F_x &= T_2 = 4.1 \text{ kg} a, \\ \sum F_y &= F_{N,3} - 40.2 \text{ N} = 0. \end{aligned}$$

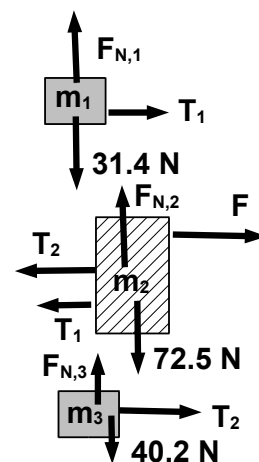

We add the equations along the horizontal:

$$T_1 + (39.0 \text{ N} - T_1 - T_2) + T_2 = 39.0 \text{ N} = (3.2 \text{ kg} + 7.2 \text{ kg} + 4.1 \text{ kg}) \cdot a$$

and solve for the acceleration:

$$a = \frac{39.0 \text{ N}}{14.5 \text{ kg}} = 2.7 \frac{\text{m}}{\text{s}^2}.$$

We find the tensions in the rods:

$$T_1 = 3.2 \text{ kg} \cdot 2.7 \frac{\text{m}}{\text{s}^2} = 8.7 \text{ N},$$

$$T_2 = 4.1 \text{ kg} \cdot 2.7 \frac{\text{m}}{\text{s}^2} = 11.1 \text{ N}.$$

This e-book  
*is made with*  
**SetaPDF**



PDF components for PHP developers

[www.setasign.com](http://www.setasign.com)



**Problem 1.19:** The forces on the rain drop are the weight  $mg = 0.045 \text{ N}$ , the normal force  $F_N$  and the static friction  $f_s$ . Since the acceleration is directed along the horizontal, we choose the  $x$ - and  $y$ -axis along the horizontal and vertical, respectively. Since  $\cos 16^\circ = 0.96$  and  $\sin 16^\circ = 0.28$ , we find

$$\begin{aligned}\sum F_x &= 0.96 \cdot f_s - 0.28 \cdot F_N = 0.0046 \text{ kg} \cdot a_c \\ \sum F_y &= 0.28 \cdot f_s + 0.96 \cdot F_N - 0.045 \text{ N} = 0\end{aligned}$$

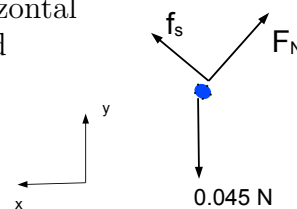

We set  $f_s = f_{s,\max} = 0.78F_N$  so that

$$0.28 \cdot 0.78 F_N + 0.96 F_N = 1.18 F_N = 0.045 \text{ N}.$$

We find the normal force  $F_N = 0.038 \text{ N}$  and the static friction  $f_{s,\max} = 0.78 \cdot 0.038 \text{ N} = 0.030 \text{ N}$ . The net force on the raindrop along the horizontal follows  $F_{\text{net},x} = 0.78 \cdot 0.030 \text{ N} - 0.28 \cdot 0.038 \text{ N} = 0.013 \text{ N}$ . Since  $F_{\text{net},x} = ma_c$ , the centripetal acceleration of the raindrop follows  $a_c = F_{\text{net},x}/m$ ,

$$a_c = \frac{0.013 \text{ N}}{0.0046 \text{ kg}} = 2.8 \frac{\text{m}}{\text{s}^2}.$$

Since  $r = 0.14 \text{ m} \cdot \cos 16^\circ = 0.13 \text{ m}$  and  $a_c = v^2/r$ , we find the speed of the raindrop  $v = \sqrt{a_c r}$ ,

$$v = \sqrt{2.8 \frac{\text{m}}{\text{s}^2} \cdot 0.13 \text{ m}} = 0.60 \frac{\text{m}}{\text{s}}.$$

The period follows from  $T = 2\pi r/v$ ,

$$T = \frac{2\pi \cdot 0.13 \text{ m}}{0.60 \text{ m/s}} = 1.35 \text{ s}.$$

We get about 2 revolutions in 3 seconds, or about 40 rpm.

**Problem 1.20:** We calculate the period of the Moon  $T_M = 2.36 \times 10^6 \text{ s}$  so that the angular frequency is  $\omega_M = 2\pi/T_M = 2.66 \times 10^{-6} \text{ s}^{-1}$ . We write the acceleration of the moon in terms of the gravitational acceleration on the Earth surface:

$$\frac{GM_E}{r_M^2} = g \left( \frac{R_E}{r_M} \right)^2 = \omega_M^2 r_M$$

so that the angular frequency of the rotation of the moon around the Earth follows  $r_M = (gR_E^2/\omega_M^2)^{1/3}$ ,

$$r_M = \left( \frac{9.8 \text{ m/s}^2 (6.38 \times 10^6 \text{ m})^2}{(2.66 \times 10^{-6} \text{ s}^{-1})^2} \right)^{1/3} = 383,000 \text{ km}.$$

The Moon becomes dark during the time  $\Delta t_1 = 8 \text{ min}$ . The time for the duration of a lunar eclipse follows  $\Delta t_2 = 60 \text{ min} - 2 \cdot 8 \text{ min} = 44 \text{ min}$ . If  $v_M$  is the orbital speed of the moon, we find  $2R_E/2R_M = (v_M \Delta t_2)/(v_M \Delta t_1)$ . Since  $\Delta t_2/\Delta t_1 = 44 \text{ min}/8 \text{ min} = 5.5$ , we find the radius of the Moon from the Earth radius:  $R_M = R_E/5.5$ ,

$$R_M = \frac{6300 \text{ km}}{5.5} = 1,200 \text{ km}.$$



*Note:* We find  $\omega_M^2 r_M^3 = \text{const}$ , or  $T_M^2 \sim r_M^3$ ; this is Kepler's third law derived here for the special case when the orbit is a circle [rather than an ellipse]. The correct value for the radius of the Moon is 1740 km. The radius of the Earth was first determined by Eratosthenes (276 BC - 194 BC). Our calculation shows that the distance of the Moon from the Earth and the radius of the Moon can be obtained from relatively simple astronomical observations.

**Problem 1.21:** The forces are the weight of the board 2.94 N, the weight of the block 12.74 N, and the two tensions  $\vec{T}_1$  and  $\vec{T}_2$ . Newton's second law for the board follows:

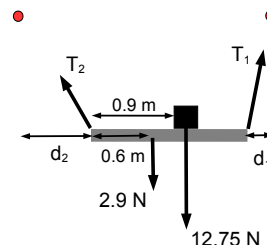

$$\begin{aligned}\sum F_x &= T_{1,x} - T_{2,x} = 0, \\ \sum F_y &= T_{1,y} + T_{2,y} - 12.74 \text{ N} - 2.94 \text{ N} = 0.\end{aligned}$$

We choose the center of the board as the axis of rotation. Since  $12.74 \text{ N} \cdot 0.3 \text{ m} = 3.82 \text{ Nm}$  is the torque produced by the weight of the board, the torque follows:

$$\sum \tau_{\text{CM}} = T_{1,y} \cdot 0.6 \text{ m} - T_{2,y} \cdot 0.6 \text{ m} - 3.82 \text{ Nm} = 0.$$

We find the sum and difference of the vertical components of the tensions:

$$\begin{aligned}T_{1,y} + T_{2,y} &= 15.7 \text{ N}, \\ T_{1,y} - T_{2,y} &= \frac{3.82 \text{ Nm}}{0.6 \text{ m}} = 6.4 \text{ N}.\end{aligned}$$

We find  $T_{1,y} = 11.1 \text{ N}$  and  $T_{2,y} = 4.6 \text{ N}$ . Since  $T_{1,x} = T_{2,x} = T_x$ , the horizontal displacement of the board towards the right determines the directions of the strings. We find for string #1:  $\tan \theta_1 = T_x / 11.1 \text{ N} = (0.3 \text{ m} - d) / 0.8 \text{ m}$ , so that

$$T_x = 11.1 \text{ N} \cdot \frac{0.3 \text{ m} - d}{0.8 \text{ m}},$$

similarly for string #2:  $\tan \theta_2 = T_x / 4.6 \text{ N} = (0.3 \text{ m} + d) / 0.8 \text{ m}$ , so that

$$T_x = 4.6 \text{ N} \cdot \frac{0.3 \text{ m} + d}{0.8 \text{ m}},$$

We obtain

$$11.1 \text{ N} \cdot \frac{0.3 \text{ m} - d}{0.8 \text{ m}} = 4.6 \text{ N} \cdot \frac{0.3 \text{ m} + d}{0.8 \text{ m}}.$$

We solve for the horizontal displacement of the board:

$$d = \frac{11.1 \text{ N} - 4.6 \text{ N}}{11.1 \text{ N} + 4.6 \text{ N}} \cdot 0.3 \text{ m} = 0.12 \text{ m}$$

The horizontal component of the tension follows:

$$T_x = \frac{0.3 \text{ m} - 0.12 \text{ m}}{0.8 \text{ m}} \cdot 11.1 \text{ N} = 2.5 \text{ N}.$$

We then find the magnitudes of tensions in the two ropes  $T_i = \sqrt{T_x^2 + T_{i,y}^2}$ ,

$$T_1 = \sqrt{(2.5 \text{ N})^2 + (11.1 \text{ N})^2} = 11.4 \text{ N},$$

$$T_2 = \sqrt{(2.5 \text{ N})^2 + (4.6 \text{ N})^2} = 5.2 \text{ N}.$$

**Problem 1.22:** The time for the tennis ball to hit the floor is independent of the pacing:  $t_g = 1.1 \text{ s}/2 = 0.55 \text{ s}$ . Since the vertical motion is described by free fall, we find the height  $h = gt_g^2/2$ , or

$$h = \frac{1}{2} 9.8 \frac{\text{m}}{\text{s}^2} \cdot (0.55 \text{ s})^2 = 1.48 \text{ m}$$

The horizontal displacement is characterized by a constant velocity  $v_{x,0}$  so that  $\Delta x = 1.7 \text{ m} = v_{x,0} t_g$  so that  $v_{x,0} = \Delta x/t_g$ ,

$$v_{x,0} = \frac{1.7 \text{ m}}{1.1 \text{ s}} = 1.5 \frac{\text{m}}{\text{s}}.$$

Since the ball is released with zero vertical speed from the person's hand, we find the vertical component of the velocity when the tennis ball hits the ground:  $v_{y,g} = -gt_g = -9.8 \text{ m/s}^2 \cdot 0.55 \text{ s} = -5.4 \text{ m/s}$ . We then find the speed of the tennis ball when it hits the ground:  $v_g = \sqrt{v_{x,0}^2 + v_{y,g}^2}$ ,

$$v_g = \sqrt{\left(1.5 \frac{\text{m}}{\text{s}}\right)^2 + \left(-5.4 \frac{\text{m}}{\text{s}}\right)^2} = 5.6 \frac{\text{m}}{\text{s}}.$$

"I studied English for 16 years but...  
...I finally learned to speak it in just six lessons"  
Jane, Chinese architect

ENGLISH OUT THERE

Click to hear me talking before and after my unique course download

**Problem 1.23:** The height of the ramp is given by  $h = s \sin \theta = 2.4 \text{ m} \sin 22^\circ = 0.9 \text{ m}$ . The kinetic energy has a contribution from rotation and translation,  $\text{KE} = mv^2/2 + I\omega^2/2$ . We find the kinetic energy  $\text{KE} = mv^2/2 + (2/5)I\omega^2/2$ . The moment of inertia of a solid sphere is given by  $I = (2/5)mr^2$ . Because the ball rolls without slipping, the angular speed  $\omega$  follows from the linear speed  $v$ :  $\omega = v/r$ . We obtain

$$\text{KE} = \frac{1}{2}mv^2 + \frac{1}{2} \cdot \frac{2}{5}mr^2 \left(\frac{v}{r}\right)^2 = \frac{7}{10}mv^2.$$

The initial gravitational potential energy  $\text{PE}_i = mgh$  is converted into kinetic energy  $mgh = (7/10)mv^2$ , so that the speed at the end of the ramp follows  $v_f = \sqrt{(10/7)gh}$ ,

$$v_f = \sqrt{\frac{10}{7} \cdot 9.8 \frac{\text{m}}{\text{s}^2} \cdot 0.9 \text{ m}} = 3.55 \frac{\text{m}}{\text{s}}.$$

The rotational speed follows  $\omega_f = v_f/r = (3.55 \text{ m/s})/(0.21 \text{ m}) = 16.9 \text{ rad/s}$  (recall that “rad” is only a placeholder). Since  $v_0 = 0$ , we find  $v_f^2 = 2as$  so that the linear acceleration along the ramp follows  $a = v_f^2/2s$ ,

$$a = \frac{(3.55 \text{ m/s})^2}{2 \cdot 2.4 \text{ m}} = 2.63 \frac{\text{m}}{\text{s}^2}$$

and for the angular acceleration:  $\alpha = a/r = (2.63 \text{ m/s}^2)/(0.21 \text{ m}) = 12.5 \text{ rad/s}^2$ . The moment of inertia of the sphere is

$$I = \frac{2}{5} 0.1 \text{ kg} \cdot (0.21 \text{ m})^2 = 1.76 \times 10^{-3} \text{ kg m}^2.$$

The torque on the sphere follows from the moment of inertia and the angular acceleration:  $\tau = I\alpha$ ,

$$\tau = 1.76 \times 10^{-3} \text{ kg m}^2 \cdot 12.5 \frac{\text{rad}}{\text{s}^2} = 0.022 \text{ Nm}.$$

The torque is produced by the *static* friction force  $\tau = f_s r$ . The static friction follows  $f_s = \tau/r$ ,

$$f_s = \frac{0.022 \text{ Nm}}{0.21 \text{ m}} = 0.105 \text{ N}.$$

The normal force on the ball is given by  $F_N = mg \cos \theta = 0.1 \text{ kg} \cdot 9.8 \text{ m/s}^2 \cdot \cos 22^\circ = 0.91 \text{ N}$ . The static friction force follows  $f_s \leq f_{s,\text{max}} = \mu_s F_N$ , we arrive at the inequality for the coefficient of static friction,  $\mu_s \geq f_s/F_N$ ,

$$\mu_s \geq \frac{0.105 \text{ N}}{0.91 \text{ N}} = 0.12.$$

If  $\mu_s < 0.12$ , the ball would slip rather than rolling,

**Problem 1.24:** We choose  $y = 0$  at the pivot so that the total energy of the bob-spring system is zero. Since energy is conserved, we find

$$\begin{aligned} E_{\text{mech}} = 0 &= \frac{1}{2} 4.1 \frac{\text{N}}{\text{m}} (1.57 \text{ m} - 0.26 \text{ m})^2 - 0.34 \text{ kg} \cdot 9.8 \frac{\text{m}}{\text{s}^2} \cdot 1.55 \text{ m} + \frac{1}{2} 0.34 \text{ kg} \cdot v^2 \\ &= 3.5 \text{ J} - 5.2 \text{ J} + \frac{1}{2} 0.34 \text{ kg} \cdot v^2. \end{aligned}$$

We solve for the speed of the bob:

$$v = \sqrt{\frac{2 \cdot (5.2 \text{ J} - 3.5 \text{ J})}{0.34 \text{ kg}}} = 3.1 \frac{\text{m}}{\text{s}}.$$

We use the length of the stretched string for the radius of the uniform circular motion of the bob. We find the centripetal acceleration of the bob:  $a_c = v^2/R$ ,

$$a_c = \frac{(3.3 \text{ m/s})^2}{1.55 \text{ m}} = 6.2 \frac{\text{m}}{\text{s}^2}.$$

The forces on the bob are the weight  $mg = 0.34 \text{ kg} \cdot 9.8 \text{ m/s}^2 = 3.3 \text{ N}$ , and the spring force so that Newton's second law for the bob gives  $F_{\text{spring}} - mg = ma_c$ . We solve for the spring force:  $F_{\text{spring}} = m(a_c + g)$ ,

$$F_{\text{spring}} = 0.34 \text{ kg} \cdot \left(6.2 \frac{\text{m}}{\text{s}^2} + 9.8 \frac{\text{m}}{\text{s}^2}\right) = 5.4 \text{ N}.$$

Alternatively, the spring force can be calculated from the displacement of the spring  $\delta = 1.55 \text{ m} - 0.26 \text{ m} = 1.29 \text{ m}$  so that

$$F_{\text{spring}} = 4.1 \frac{\text{N}}{\text{m}} \cdot 1.29 \text{ m} = 5.4 \text{ N}.$$

In mechanical equilibrium, the net force on the bob vanishes so that  $F'_{\text{spring}} = mg = 3.3 \text{ N}$ . The height of the bob below the pivot follows,

$$y_{\text{eq}} = \frac{3.3 \text{ N}}{4.1 \text{ N/m}} + 0.26 \text{ m} = 1.06 \text{ m}.$$



# FOSS

## Sharp Minds - Bright Ideas!

Employees at FOSS Analytical A/S are living proof of the company value - First - using new inventions to make dedicated solutions for our customers. With sharp minds and cross functional teamwork, we constantly strive to develop new unique products - Would you like to join our team?

FOSS works diligently with innovation and development as basis for its growth. It is reflected in the fact that more than 200 of the 1200 employees in FOSS work with Research & Development in Scandinavia and USA. Engineers at FOSS work in production, development and marketing, within a wide range of different fields, i.e. Chemistry, Electronics, Mechanics, Software, Optics, Microbiology, Chemometrics.

**We offer**  
A challenging job in an international and innovative company that is leading in its field. You will get the opportunity to work with the most advanced technology together with highly skilled colleagues.

Read more about FOSS at [www.foss.dk](http://www.foss.dk) - or go directly to our student site [www.foss.dk/sharpminds](http://www.foss.dk/sharpminds) where you can learn more about your possibilities of working together with us on projects, your thesis etc.

The Family owned FOSS group is the world leader as supplier of dedicated, high-tech analytical solutions which measure and control the quality and production of agricultural, food, pharmaceutical and chemical products. Main activities are initiated from Denmark, Sweden and USA with headquarters domiciled in Hillerød, DK. The products are marketed globally by 23 sales companies and an extensive net of distributors. In line with the corevalue to be 'First', the company intends to expand its market position.

Dedicated Analytical Solutions

FOSS  
Slangerupgade 69  
3400 Hillerød  
Tel. +45 70103370  
[www.foss.dk](http://www.foss.dk)





We find the total potential energy of the bob [gravitational *plus* elastic]:  $PE_{\text{eq}} = -mgy_{\text{eq}} + (k/2)(y_{\text{eq}} - 0.26 \text{ m})^2$ ,

$$PE_{\text{eq}} = -3.3 \text{ N} \cdot 1.06 \text{ m} + \frac{1}{2} 4.1 \frac{\text{N}}{\text{m}} \cdot (0.81 \text{ m})^2 = -2.2 \text{ J}.$$

Since the initial mechanical energy is zero, the dissipated energy is equal to the loss of potential energy  $E_{\text{diss}} = -PE_{\text{eq}} = 2.2 \text{ J}$ .

**Problem 1.25:** Harry and Emmy pass each other at the time  $t^*$ :  $d_E = v_E t^* = 39.3 \text{ m}$  and  $d_H = v_H t^* = 91.4 \text{ m} - 39.3 \text{ m} = 52.1 \text{ m}$ . Harry finishes in the time  $T$  so that  $v_E T = 91.4 \text{ m}$ . The ratio of the two speeds  $v_E/v_H$  can be written:  $v_E t^*/v_H t^* = v_E T/v_H T$ , so that  $39.3 \text{ m}/52.1 \text{ m} = D_E/91.4 \text{ m}$ . We solve for the distance run by Emmy:

$$D_E = 91.4 \text{ m} \cdot \frac{39.3 \text{ m}}{52.1 \text{ m}} = 68.9 \text{ m},$$

or about 75 yards. Emmy runs to the end of the field:  $\Delta D_E = 91.4 \text{ m} - 68.9 \text{ m} = 22.5 \text{ m}$ . Emmy runs the additional time  $\Delta t = 5.2 \text{ s}$ . We thus find Emmy's speed  $v_E = \Delta D_E/\Delta t$ , or

$$v_E = \frac{22.5 \text{ m}}{5.2 \text{ s}} = 4.3 \frac{\text{m}}{\text{s}}.$$

Harry's speed follows from  $v_H = (d_H/d_E)v_E$ ,

$$v_H = \frac{52.1 \text{ m}}{39.3 \text{ m}} \cdot 4.3 \frac{\text{m}}{\text{s}} = 5.7 \frac{\text{m}}{\text{s}}.$$

**Problem 1.26:** We find the forces acting on the block: the weight  $mg = 12 \text{ N}$  and the normal force  $F_N$ . The forces on the wedge: the weight of the wedge  $Mg = 52 \text{ N}$ , the normal force  $F_N$ , the "ground reaction force" [i.e., the normal force exerted by the ground]  $F_G$ , and the applied force  $F$ . Since the common acceleration of the block and the wedge is along the horizontal, we choose the  $x$ -axis along the horizontal and the  $y$ -axis along the vertical:  $a_x = a$  and  $a_y = 0$ . Newton's second law for the for the block follows

$$\begin{aligned} \sum F_x &= 0.53 F_N = 1.2 \text{ kg} \cdot a, \\ \sum F_y &= 0.85 F_N - 12 \text{ N} = 0, \end{aligned}$$

and Newton's second law for the wedge:

$$\begin{aligned} \sum F_x &= F - 0.53 F_N = 5.3 \text{ kg} \cdot a, \\ \sum F_y &= F_G - 0.85 F_N - 52 \text{ N} = 0. \end{aligned}$$

We find the normal force with the incline:

$$F_N = \frac{12 \text{ N}}{0.85} = 14.1 \text{ N}.$$

The magnitude of the common acceleration of both the block and the wedge follows:

$$a = \frac{0.53 \cdot 14.1 \text{ N}}{1.2 \text{ kg}} = 6.2 \frac{\text{m}}{\text{s}^2}.$$

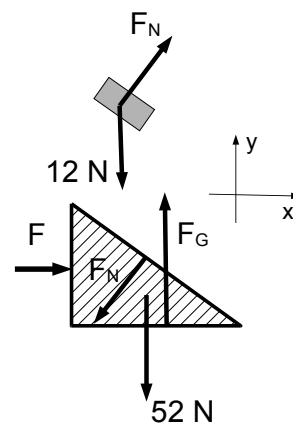

The magnitude of the applied force follows

$$F = 0.53 \cdot 14.1 \text{ N} + 5.3 \text{ kg} \cdot 6.2 \frac{\text{m}}{\text{s}^2} = 40.4 \text{ N}.$$

Note that  $F_G = 52 \text{ N} + 12 \text{ N} = (M + m)g$ . This makes sense: the ground reaction force [along the vertical!] is independent of the motion along the horizontal direction.

**Problem 1.27:** Since linear momentum is conserved for any collision [elastic or inelastic], we find

$$3.5 \text{ kg} \cdot 4.2 \frac{\text{m}}{\text{s}} = 3.5 \text{ kg} \cdot \left(-0.75 \frac{\text{m}}{\text{s}}\right) + 5.0 \text{ kg} \cdot v_{2,f},$$

and solve for the speed of the block  $m_2$  after the collision:

$$v_{2,f} = \frac{3.5 \text{ kg}}{5.0 \text{ kg}} \cdot \left[4.2 \frac{\text{m}}{\text{s}} + 0.75 \frac{\text{m}}{\text{s}}\right] = 3.5 \frac{\text{m}}{\text{s}}.$$

The problem states that the collision is *elastic*; that is, mechanical energy is also conserved during the collision. Because the track is level, gravitational potential energy can be ignored. When the blocks are separated, the metal strip is in its equilibrium position and the elastic potential energy can also be ignored. We thus consider only the kinetic energies of the two blocks:

$$\frac{3.5 \text{ kg}}{2} \left(4.2 \frac{\text{m}}{\text{s}}\right)^2 = \frac{3.5 \text{ kg}}{2} \left(-0.75 \frac{\text{m}}{\text{s}}\right)^2 + \frac{5.0 \text{ kg}}{2} v_{2,f}^2,$$

and solve for the speed of the block  $m_2$  after the collision.

$$v_{2f} = \sqrt{\frac{2 \cdot (30.9 \text{ J} - 1.0 \text{ J})}{5.0 \text{ kg}}} = 3.5 \frac{\text{m}}{\text{s}}.$$

*The two methods of course yield the same result!* Linear momentum is conserved at all times, independent of the compression of the spring; the conservation of momentum now reads,

$$3.5 \text{ kg} \cdot 4.2 \frac{\text{m}}{\text{s}} = 5.0 \text{ kg} \cdot v_2^*.$$

The speed of the block  $v_2^*$  when the spring is compressed follows

$$v_2^* = \frac{3.5 \text{ kg}}{5.0 \text{ kg}} \cdot 4.2 \frac{\text{m}}{\text{s}} = 3.0 \frac{\text{m}}{\text{s}}.$$

We use the conservation of energy to find the elastic potential energy stored in the spring at that instant:

$$\frac{3.5 \text{ kg}}{2} \left(4.2 \frac{\text{m}}{\text{s}}\right)^2 = \text{PE}^* + \frac{5.0 \text{ kg}}{2} \left(3.0 \frac{\text{m}}{\text{s}}\right)^2.$$

The elastic potential energy follows  $\text{PE}^* = 30.9 \text{ J} - 22.5 \text{ J} = 8.4 \text{ J}$ . The elastic potential energy is determined by the spring constant and  $k$  and the compression of the spring  $d^*$ :  $\text{PE}^* = 5.0 \times 10^3 \text{ N/m} \cdot (d^*)^2/2$ , we find,

$$d^* = \sqrt{\frac{2 \cdot 8.4 \text{ J}}{5.0 \times 10^3 \text{ N/m}}} = 5.8 \text{ cm}.$$

**Problem 1.28:** We use geometry to calculate the height where the pearl is released:

$$h = 0.12 \text{ m} \cdot (1 - \cos 27.0^\circ) = 0.013 \text{ m}.$$

We use the moment of inertia of a solid sphere  $I = 2mr^2/5$  and the angular speed  $\omega = v/r$  [for rolling without slipping]. We then find the sum of the translational and rotational kinetic energy of the pearl at the bottom of bowl,  $\text{KE} = mv^2/2 + (2mr^2/5)(v/r)^2/2 = 7mv^2/10$ . The conservation of energy then yields  $mgh = (7/10)mv^2$ . We solve for the speed  $v = \sqrt{(10/7)gh}$ , or

$$v = \sqrt{\frac{10}{7} \cdot 9.8 \frac{\text{m}}{\text{s}^2} \cdot 0.013 \text{ m}} = 0.42 \frac{\text{m}}{\text{s}}.$$

The amplitude of the harmonic motion follows from the radius  $R = 0.12 \text{ m}$  and the angle  $\theta_0 = 27^\circ$ ,  $A = R \sin \theta_0$ ,

$$A = 0.12 \text{ m} \cdot \sin 27.0^\circ = 0.054 \text{ m}.$$

The bottom of the bowl is the equilibrium position of the harmonic motion so that the maximum speed is equal to the speed of the pearl at the bottom:  $v_{\text{max}} = 0.42 \text{ m/s} = A\omega = (2\pi/T)0.054 \text{ m}$ . The period of the harmonic motion follows,

$$T = \frac{2\pi \cdot 0.054 \text{ m}}{0.42 \text{ m/s}} = 0.79 \text{ s}.$$

We find the time to reach the bottom of the bowl:  $t = T/4 = 0.20 \text{ s}$ .

**gaiTeye**  
Challenge the way we run

**EXPERIENCE THE POWER OF  
FULL ENGAGEMENT...**

**RUN FASTER.  
RUN LONGER..  
RUN EASIER...**

**READ MORE & PRE-ORDER TODAY  
WWW.GAITEYE.COM**

**Problem 1.29:** The forces are the weight of the board  $Mg$ , the weight of the block  $mg$ , the tension in the rope  $T$ , and the support from the cone  $T_s$ . Newton's second law for the board yields:

$$\sum F_y = T + T_s - mg - Mg = 0.$$

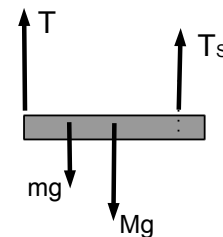

We choose the support as the axis of rotation. We use  $d$  for the distance between the position of the block and the cone. Then torque follows

$$\sum \tau = mg \cdot d + Mg \cdot 1.5 \text{ m} - T \cdot 3.5 \text{ m} = 0.$$

We find  $d_1 = 2.5 \text{ m}$  ( $d_2 = 2.0 \text{ m}$ ) for  $T_1 = 27.4 \text{ N}$  ( $T_2 = 15.7 \text{ N}$ ). The torque equation yields

$$mg \cdot 2.5 \text{ m} + Mg \cdot 1.5 \text{ m} - 27.4 \text{ N} \cdot 3.5 \text{ m} = 0,$$

$$mg \cdot 2.0 \text{ m} + Mg \cdot 1.5 \text{ m} - 15.7 \text{ N} \cdot 3.5 \text{ m} = 0.$$

We subtract the two equations from each other:

$$mg \cdot (2.5 \text{ m} - 2.0 \text{ m}) - (27.4 \text{ N} - 15.7 \text{ N}) \cdot 3.5 \text{ m} = 0,$$

and solve for the weight of the block on the board:

$$mg = \frac{(27.4 \text{ N} - 15.7 \text{ N}) \cdot 3.5 \text{ m}}{2.5 \text{ m} - 2.0 \text{ m}} = 81.9 \text{ N},$$

so that the mass of the block follows  $m = 8.4 \text{ kg}$ .

**Problem 1.30:** Before the squirt, the total momentum of the squid and the water is zero  $P_{\text{tot}} = 0$ . After the squirt, the velocity of the water follows  $v_w = -3.0 \text{ m/s}$ , i.e., the water moves towards the “left.” We use the conservation of linear momentum:  $P_{\text{tot}} = 0 = m_w v_w + M_s v_s$ , or  $v_{\text{squid}} = -m_w v_w / M_s$ ,

$$v_{\text{squid}} = -\frac{0.1 \text{ kg} \cdot (-3.0 \text{ m/s})}{0.4 \text{ kg}} = 0.75 \frac{\text{m}}{\text{s}}.$$

We now consider only the squid as the system. The change in the linear momentum of the squid follows  $\Delta P_{\text{squid}} = M_s v_s$ ,

$$\Delta P_{\text{squid}} = 0.4 \text{ kg} \cdot 0.75 \frac{\text{m}}{\text{s}} = 0.3 \frac{\text{kg m}}{\text{s}}.$$

The change of momentum is equal to the impulse  $J_{\text{squid}} = \Delta P_{\text{squid}} = 0.3 \text{ kg m/s}$ . The (average) force exerted by the water on the squid then follows from the impulse  $J = F \Delta t$  so that  $F_{\text{ave}} = J_{\text{squid}} / \Delta t$

$$F_{\text{ave}} = \frac{0.3 \text{ kg m/s}}{0.5 \text{ s}} = 0.6 \text{ N}.$$

Here,  $F_{\text{ave}} > 0$  implies that the force on the squid acts towards the “right.”

**Problem 1.31:** The elastic potential energy of the spring is given by  $\text{PE}_{\text{el}} = kx^2/2$ ,

$$\text{PE}_{\text{el}} = \frac{1}{2} 750 \frac{\text{N}}{\text{m}} \cdot (6.0 \times 10^{-2} \text{ m})^2 = 1.35 \text{ J}.$$



This energy is transformed into kinetic energy of the block:  $1.35 \text{ J} = mv^2/2$  or

$$v = \sqrt{\frac{2 \cdot 1.35 \text{ J}}{0.5 \text{ kg}}} = 2.3 \frac{\text{m}}{\text{s}}.$$

The work done by the friction force is  $W_{\text{nc}} = -f_k d = -1.35 \text{ J}$ . The friction force follows  $f_k = -W_{\text{nc}}/d$ ,

$$f_k = -\frac{-1.35 \text{ J}}{0.7 \text{ m}} = 1.93 \text{ N}.$$

The normal force is equal to the weight of the block  $F_N = mg = 0.5 \text{ kg} \cdot 9.8 \text{ m/s}^2 = 4.9 \text{ N}$ . Since  $f_k = \mu_k F_N$ , we find the coefficient of kinetic friction  $\mu_k = f_k/F_N$ ,

$$\mu_k = \frac{1.93 \text{ N}}{4.9 \text{ N}} = 0.39.$$

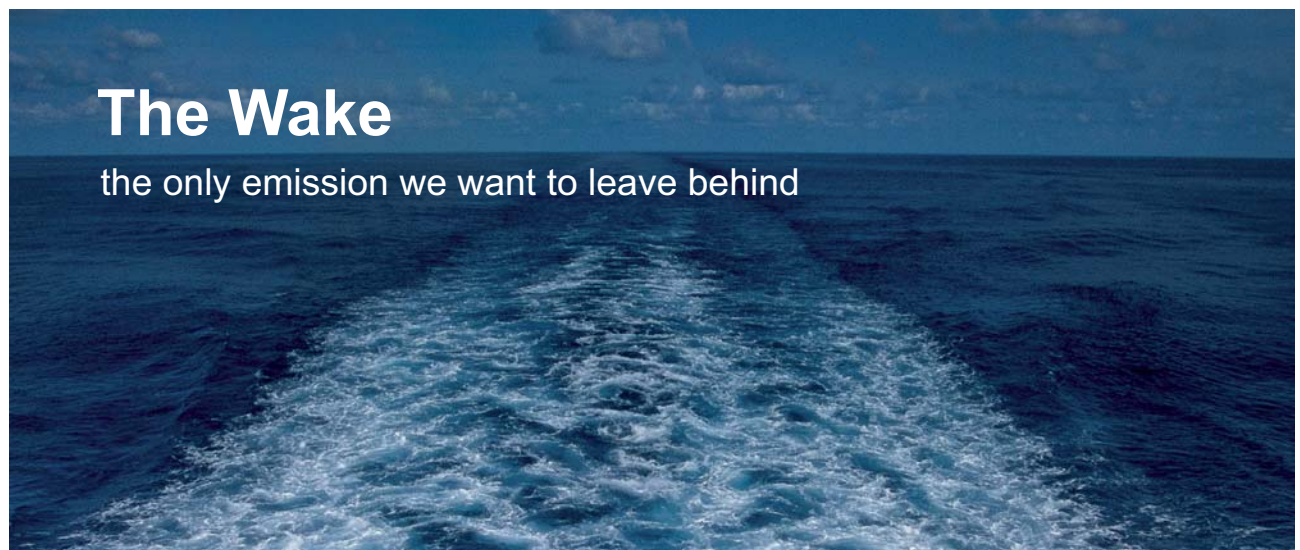

## The Wake

the only emission we want to leave behind

Low-speed Engines Medium-speed Engines Turbochargers Propellers Propulsion Packages PrimeServ

The design of eco-friendly marine power and propulsion solutions is crucial for MAN Diesel & Turbo. Power competencies are offered with the world's largest engine programme – having outputs spanning from 450 to 87,220 kW per engine. Get up front! Find out more at [www.mandieselturbo.com](http://www.mandieselturbo.com)

Engineering the Future – since 1758.

### MAN Diesel & Turbo



**Problem 1.32:** Since Emmy and the dumbbell are initially at the center of the (uniform) boat, the center of mass is at the center of the boat,

$$x_{\text{CoM}} = \frac{3.2 \text{ m}}{2} = 1.6 \text{ m}.$$

The total mass  $M_{\text{total}} = 310 \text{ kg} + 10 \text{ kg} = 320 \text{ kg}$ , so that

$$M_{\text{total}} x_{\text{CoM}} = 320 \text{ kg} \cdot 1.6 \text{ m} = 496 \text{ kg m}.$$

We use  $d_1 = 5.0 \text{ cm} = 0.05 \text{ m}$ . Since the center of mass is fixed, we find

$$[(m_E + m_B) + 10 \text{ kg}] \cdot \frac{3.2 \text{ m}}{2} = (m_E + m_B) \cdot \left( \frac{3.2 \text{ m}}{2} + 0.05 \text{ m} \right) + 10.0 \text{ kg} \cdot 0.05 \text{ m}.$$

We obtain  $(m_E + m_B) \cdot 1.6 \text{ m} + 16.0 \text{ kg m} = (m_E + m_B) \cdot 1.65 \text{ m} + 0.5 \text{ kg m}$  so that  $(m_E + m_B) \cdot 0.05 \text{ m} = 15.5 \text{ kg m}$ . We thus find the sum of the mass of Emmy and the board:

$$m_E + m_B = \frac{15.5 \text{ kg m}}{0.05 \text{ m}} = 310 \text{ kg}.$$

When both Emmy and the dumbbell are at the stern, the boat has moved  $d_1 + d_2 = 0.26 \text{ m}$ , we find

$$\begin{aligned} 496 \text{ kg m} &= (10 \text{ kg} + m_E) \cdot 0.26 \text{ m} + (310 \text{ kg} - m_E) \cdot (1.6 \text{ m} + 0.26 \text{ m}) \\ &= 2.6 \text{ kg m} + 576.6 \text{ kg m} - m_E \cdot 1.6 \text{ m}. \end{aligned}$$

We solve for the mass of Emmy:

$$m_E = \frac{576.6 \text{ kg m} + 2.6 \text{ kg m} - 496 \text{ kg m}}{1.6 \text{ m}} = 52.0 \text{ kg}.$$

The mass of the boat then follows  $m_B = (m_E + m_B) - m_E$ ,

$$m_B = 310 \text{ kg} - 52 \text{ kg} = 258 \text{ kg}.$$

**Problem 1.33:** The block undergoes simple harmonic motion. The block is in the equilibrium position at the time  $t = 0$ , and is at the turning point at  $t = 0.52 \text{ s}$ . We conclude that  $0.52 \text{ s}$  is a quarter of the period so that  $T = 4 \cdot 0.52 \text{ s} = 2.08 \text{ s}$ . Since the period is determined by the spring constant and the (total) mass  $M + m$ . We find the period  $T = 2\pi\sqrt{(M + m)/k}$ , we find  $M + m = k(T/2\pi)^2$ ,

$$M + m = 13.0 \frac{\text{N}}{\text{m}} \cdot \left( \frac{2.08 \text{ s}}{2\pi} \right)^2 = 1.42 \text{ kg}.$$

The mass of the clay follows  $m = 1.42 \text{ kg} - 1.1 \text{ kg} = 0.32 \text{ kg}$ . The elastic potential energy of the compressed spring is given by  $\text{PE}_{\text{spring}} = kd^2/2$ ,

$$\text{PE}_{\text{spring}} = \frac{1}{2} 13.0 \frac{\text{N}}{\text{m}} (0.067 \text{ m})^2 = 2.9 \times 10^{-2} \text{ J}.$$

Because the spring is completely relaxed at the initial time  $t = 0$ , the elastic energy of the spring is equal to the kinetic energy of the (block and clay) when the block *plus* clay start to move:  $PE_{\text{spring}} = KE_i = (M + m)v_0^2/2$ , or  $v_0 = \sqrt{2PE_{\text{spring}}/(M + m)}$ ,

$$v_0 = \sqrt{\frac{2 \cdot 2.9 \times 10^{-2} \text{ J}}{1.42 \text{ kg}}} = 0.2 \frac{\text{m}}{\text{s}}.$$

We describe the impact of the clay with the block as an inelastic collision. We use the conservation of linear momentum  $1.42 \text{ kg} \cdot 0.2 \text{ m/s} = 0.32 \text{ kg} \cdot v$ , or

$$v = \frac{1.42 \text{ kg}}{0.32 \text{ kg}} \cdot 0.2 \frac{\text{m}}{\text{s}} = 0.89 \frac{\text{m}}{\text{s}}.$$

**Problem 1.34:** The total mechanical energy of the ring is equal to potential energy  $E_{\text{mech}} = PE_i = mgH$ ,

$$E_{\text{mech}} = 0.12 \text{ kg} \cdot 9.8 \frac{\text{m}}{\text{s}^2} \cdot 1.54 \text{ m} = 1.81 \text{ J}.$$

The potential energy of the ring near the top of the ring is  $PE_f = mg2R$ ,

$$PE_f = 0.12 \text{ kg} \cdot 9.8 \frac{\text{m}}{\text{s}^2} \cdot 0.84 \text{ m} = 0.99 \text{ J}.$$

We use the conservation of mechanical energy  $E_{\text{mech}} = KE_f + PE_f$ , and find the kinetic energy of the ring at the top of the loop:  $KE_f = E_{\text{mech}} - PE_f$ ,

$$KE_f = 1.81 \text{ J} - 0.99 \text{ J} = 0.82 \text{ J}.$$

The kinetic energy of the ring is [translation and rotation]  $KE = mv^2/2 + I\omega^2/2$ . We insert the moment of inertia of the ring  $I = mr^2$  and use the condition of rolling without slipping  $\omega = v/r$ , and obtain  $KE = mv^2/2 + (mr^2) \cdot (v/r)^2/2$ , or  $KE = mv^2$ . We solve for the linear speed of the ring near the top:  $v_{\text{top}} = \sqrt{KE_f/m}$ ,

$$v_{\text{top}} = \sqrt{\frac{0.82 \text{ J}}{0.12 \text{ kg}}} = 2.61 \frac{\text{m}}{\text{s}}.$$

The forces acting on the ring are the normal force  $F_N$  from the track [downward] and the weight of the ring  $mg$ . Since the ring undergoes circular motion the acceleration is  $a_c = v_f^2/R$ , so that Newton's second law for the ring yields,  $F_N + mg = ma = mv_f^2/R$ . We thus get for the normal force exerted by the track:  $F_N = m [v_f^2/R - g]$ ,

$$F_N = 0.12 \text{ kg} \cdot \left( \frac{(2.61 \text{ m/s})^2}{0.42 \text{ m}} - 9.8 \frac{\text{m}}{\text{s}^2} \right) = 0.76 \text{ N}.$$

Because  $F_N > 0$ , the ring stays on the track.

**Problem 1.35:** The final angular velocity is given by  $\omega_f = 41.3 \text{ rad/s}$  so that the angular acceleration:  $\alpha = \Delta\omega/\Delta t$ ,

$$\alpha = \frac{41.3 \text{ rad/s}}{6.3 \text{ s}} = 6.5 \frac{\text{rad}}{\text{s}^2}.$$

he angular displacement is given by  $\Delta\theta = \alpha t^2/2$ ,

$$\Delta\theta = \frac{1}{2} 6.5 \frac{\text{rad}}{\text{s}^2} (6.3 \text{ s})^2 = 129.0 \text{ rad}.$$

This is about 20.7 revolutions. Since the wheel rolls without slipping, we find the distance along the incline from the arc length:  $s = R\Delta\theta$ ,

$$s = 0.23 \text{ m} \cdot 129.2 \text{ rad} = 29.7 \text{ m}.$$

Since  $s = at^2/2$ , we find the linear acceleration:

$$a = \frac{2s}{t^2} = \frac{2 \cdot 29.7 \text{ m}}{(6.3 \text{ s})^2} = 1.5 \frac{\text{m}}{\text{s}^2}.$$

The moment of inertia of the wheel is  $I = mR^2$ ,

$$I = 1.2 \text{ kg} \cdot (0.23 \text{ m})^2 = 0.063 \text{ kg m}^2.$$

The torque about the axis on the wheel follows  $\tau = I\alpha$ ,

$$\tau = 0.063 \text{ kg m}^2 \cdot 6.5 \frac{\text{rad}}{\text{s}^2} = 0.41 \text{ Nm}.$$

The torque is produced by the static friction between the wheel and the incline:  $\tau = f_s R$ , so that the static friction follows  $f_s = \tau/R$ , or

$$f_s = \frac{0.41 \text{ Nm}}{0.23 \text{ m}} = 1.78 \text{ N}.$$

The net force on the wheel along the incline is  $F_{\text{net}} = ma$ ,

$$F_{\text{net}} = 1.2 \text{ kg} \cdot 1.5 \frac{\text{m}}{\text{s}^2} = 1.78 \text{ N}.$$

We note that  $f_s = F_{\text{net}}$ . The weight of the wheel is  $mg = 1.2 \text{ kg} \cdot 9.8 \text{ m/s}^2 = 11.8 \text{ N}$ . The net force along the incline is equal to the component of the weight along the incline and the static friction:  $F_{\text{net}} = mg \sin \phi - f_s$  so that

$$mg \sin \phi = F_{\text{net}} + f_s = 2F_{\text{net}}.$$

We find  $mg \sin \phi = 2 \cdot 1.78 \text{ N} = 3.76 \text{ N}$  We find

$$\sin \phi = \frac{3.76 \text{ N}}{11.8 \text{ N}} = 0.32,$$

so that the angle follows

$$\phi = 18.6^\circ.$$

*Note:* A common mistake is to use the expression  $a = g \sin \phi^*$ . Note that this expression is only correct if the wheel *slides*, rather than rolls down the incline. We would find  $\phi^* = 8.8^\circ$ . Thus,  $\phi > \phi^*$  which reflects the fact that the linear acceleration of rolling objects is *less* than the acceleration of sliding objects in the absence of friction.

**Problem 1.36:** The forces are weight of the person  $mg = 735 \text{ N}$ , the tension in the rope  $T$ , the normal force  $F_{\text{wall}}$ , and the static friction force  $f_s$ . The rope makes the angle  $\theta$  with the vertical:  $\sin \theta = (0.9 \text{ m} + 0.15 \text{ m})/3.0 \text{ m}$  so that  $\theta = 20.5^\circ$ . Newton's second law for the climber yields,

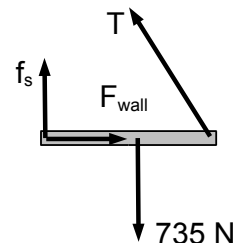

$$\begin{aligned}\sum F_x &= F_{\text{wall}} - T \sin 20.5^\circ = 0, \\ \sum F_y &= T \cos 20.5^\circ + f_s - 735 \text{ N} = 0.\end{aligned}$$

We choose the point of contact between feet and wall as the axis of rotation:

$$\sum \tau = -735 \text{ N} \cdot 0.9 \text{ m} + T \cdot 1.05 \text{ m} \cdot \sin 69.5^\circ = 0.$$

We find the tension in the rope:

$$T = \frac{735 \text{ N} \cdot 0.9 \text{ m}}{1.05 \text{ m} \cdot \sin 69.5^\circ} = 673 \text{ N}.$$

Inserted into Newton's second laws along the horizontal gives the normal force exerted by the wall:

$$F_{\text{wall}} = 673 \text{ N} \cdot \sin 20.5^\circ = 236 \text{ N},$$

and Newton's second law along the vertical gives the static friction:

$$f_s = 735 \text{ N} - 673 \text{ N} \cdot \cos 20.5^\circ = 105 \text{ N}.$$

The torque equation follows:  $T' \cos \theta' = 661.5 \text{ Nm}/1.05 \text{ m} = 630 \text{ N}$ . We set  $f_s = f_{s,\text{max}} = 0.63 \cdot F_{\text{wall}}$ . Thus  $630 \text{ N} + 0.63 F_{\text{wall}} - 735 \text{ N} = 0$ , or  $F_{\text{wall}} = (735 \text{ N} - 630 \text{ N})/0.63 = 166.7 \text{ N}$ . Since  $F_{\text{wall}} - T' \sin \theta' = 0$ , we get  $F_{\text{wall}} = T' \sin \theta' = (630 \text{ N}/\cos \theta') \sin \theta' = 630 \text{ N} \tan \theta'$ . We obtain

$$\tan \theta' = \frac{166.7 \text{ N}}{630 \text{ N}} = 0.265,$$

so that the angle follows  $\theta' = 14.8^\circ$ . We find the minimum length of the rope,

$$L > L_{\text{min}} = \frac{1.05 \text{ m}}{\sin 14.8^\circ} = 4.1 \text{ m}.$$

**Problem 1.37:** We find the angular speed of the person in phase 1:  $\omega_1 = 2\pi/T = 2\pi \text{ rad}/(2.2 \text{ s}) = 2.86 \text{ rad/s}$ . We then find the angular momentum of the person:  $L = I_1 \omega_1$ :

$$L = 2.86 \frac{\text{rad}}{\text{s}} \cdot 14.6 \text{ kg m}^2 = 41.8 \frac{\text{kg m}^2}{\text{s}},$$

and the rotational kinetic energy:  $KE_{\text{rot},1} = I_1\omega_1^2/2$ ,

$$KE_{1,\text{rot}} = \frac{1}{2} 14.6 \text{ kg m}^2 \cdot \left(2.86 \frac{\text{rad}}{\text{s}}\right)^2 = 59.7 \text{ J}.$$

Since there is no torque acting on the center of mass of the person, the angular momentum is conserved so that  $L = I_2\omega_2$ , or  $\omega_2 = L/I_2$

$$\omega_2 = \frac{41.8 \text{ kg m}^2/\text{s}}{6.9 \text{ kg m}^2} = 6.1 \frac{\text{rad}}{\text{s}}.$$

The period follows  $T_2 = 2\pi/\omega_2 = (2\pi \text{ rad})/(6.1 \text{ rad/s}) = 1.03 \text{ s}$ . The rotational kinetic energy of the person at the highest point:  $KE_{2,\text{rot}} = I_2\omega_2^2/2$ , or

$$KE_{2,\text{rot}} = \frac{1}{2} 6.9 \text{ kg m}^2 \cdot \left(6.1 \frac{\text{rad}}{\text{s}}\right)^2 = 128.4 \text{ J}.$$

We use work-kinetic energy theorem to find the work done as the person goes from phase 1 to phase 2:  $W = KE_{2,\text{rot}} - KE_{1,\text{rot}}$

$$W = 128.4 \text{ J} - 59.7 \text{ J} = 68.7 \text{ J}.$$

This work is done by the muscles [mostly in arms and legs] of the person. Note that the muscles force is considered *external*.

I joined MITAS because  
I wanted **real responsibility**

The Graduate Programme  
for Engineers and Geoscientists  
[www.discovermitas.com](http://www.discovermitas.com)



**Month 16**

I was a construction supervisor in the North Sea advising and helping foremen solve problems

Real work  
International opportunities  
Three work placements





**Problem 1.38:** We find the displacement of the projectile  $\Delta y = v_{\text{ave}}t$ ,

$$\Delta y = -6.8 \frac{\text{m}}{\text{s}} \cdot 14.4 \text{ s} = -97.9 \text{ m},$$

Since the projectile travels from the top of the tower to the ground, we find the height of the tower  $H = 97.9 \text{ m}$ . The distance traveled by the rocket:

$$D = 31.2 \frac{\text{m}}{\text{s}} \cdot 14.4 \text{ s} = 449.3 \text{ m}.$$

Since  $D = H + 2h$ , we find for the maximum height of the projectile above the top of the tower  $h = (D - H)/2$ ,

$$h = \frac{449.3 \text{ m} - 97.9 \text{ m}}{2} = 175.7 \text{ m}.$$

Since the vertical speed at the highest point is zero  $v = 0$ , we find the launch speed from the maximum height above launch  $v_0^2 = 2gh$ , or  $v_0 = \sqrt{2gh}$ ,

$$v_0 = \sqrt{2 \cdot 9.8 \frac{\text{m}}{\text{s}^2} \cdot 175.7 \text{ m}} = 58.7 \frac{\text{m}}{\text{s}}.$$

**Problem 1.39:** The forces on the two masses are the weights  $m_1g = 6.9 \text{ N}$  and  $m_2g = 8.8 \text{ N}$ , the tensions in the rope  $T_1$  and  $T_2$ , and the normal forces,  $F_{N1}$  and  $F_{N2}$ . Since  $m_1g \sin \theta_1 = 4.8 \text{ N}$  and  $m_1g \cos \theta_1 = 5.5 \text{ N}$ , Newton's second law for the block  $m_1$ :

$$\begin{aligned} \sum F_x &= 4.8 \text{ N} - T_1 = 0.7 \text{ kg} \cdot a, \\ \sum F_y &= F_{N1} - 5.5 \text{ N} = 0. \end{aligned}$$

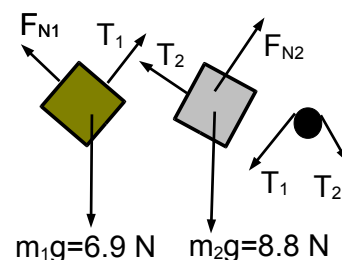

Since  $m_2g \sin \theta_2 = 1.5 \text{ N}$  and  $m_2g \cos \theta_2 = 8.7 \text{ N}$ , Newton's second law for block  $m_2$  follows,

$$\begin{aligned} \sum F_x &= T_2 - 1.5 \text{ N} = 0.9 \text{ kg} \cdot a \\ \sum F_y &= F_{N2} - 8.7 \text{ N} = 0. \end{aligned}$$

The equation of the torque of the pulley yields:

$$\sum \tau = (T_1 - T_2)r = I\alpha.$$

Since the pulley rotates without slipping, the angular acceleration is given by  $\alpha = a/r$ . We then find,  $T_1 - T_2 = (I/r^2)a$ ,

$$T_1 - T_2 = \frac{3.2 \times 10^{-4} \text{ kg m}^2}{(2.3 \times 10^{-2} \text{ m})^2} \cdot a = 0.60 \text{ kg} \cdot a.$$

We write the tension  $T_2$  in terms of  $T_1$ :  $T_2 = T_1 - 0.6 \text{ kg} \cdot a$ , Inserted in the equations for the two blocks:

$$\begin{aligned} 4.8 \text{ N} - T_1 &= 0.7 \text{ kg} \cdot a, \\ T_1 - 0.6 \text{ kg} \cdot a - 1.5 \text{ N} &= 0.9 \text{ kg} \cdot a. \end{aligned}$$

We eliminate  $T_1$  by adding the two equations:  $4.8 \text{ N} - 1.53 \text{ N} = (0.7 \text{ kg} + 0.9 \text{ kg} + 0.6 \text{ kg}) \cdot a$ ,  
or  $3.3 \text{ N} = 2.2 \text{ kg} \cdot a$ , so that the acceleration follows

$$a = \frac{3.3 \text{ N}}{2.2 \text{ kg}} = 1.5 \frac{\text{m}}{\text{s}^2}.$$

We find the tensions in the two ropes:

$$T_1 = 4.8 \text{ N} - 0.7 \text{ kg} \cdot 1.5 \frac{\text{m}}{\text{s}^2} = 3.7 \text{ N},$$

$$T_2 = 1.5 \text{ N} + 0.9 \text{ kg} \cdot 1.5 \frac{\text{m}}{\text{s}^2} = 2.9 \text{ N}.$$



www.job.oticon.dk

oticon  
PEOPLE FIRST





**Problem 1.40:** The forces are the weight  $mg = 7.2 \text{ kg} \cdot 9.8 \text{ m/s}^2 = 70.6 \text{ N}$ , the horizontal and vertical components of the tension in the rope,  $T_x$  and  $T_y$ , the normal force  $F_N$ , and the kinetic friction,  $f_k = \mu_k F_N$ . Newton's second law for plank along the horizontal and vertical is given by,

$$\begin{aligned}\sum F_x &= T_x - f_k = 0, \\ \sum F_y &= T_y + F_N - 70.6 \text{ N} = 0.\end{aligned}$$

We choose the the top end of the plank as the axis of rotation. Since  $70.6 \text{ N} \cdot (5.2 \text{ m}/2) \cdot \cos 41^\circ = 138.5 \text{ Nm}$  is the torque produced by the weight of the table, we find

$$\sum \tau = 138.5 \text{ Nm} - F_N \cdot 5.2 \text{ m} \cdot \cos 41^\circ - f_k \cdot 5.2 \text{ m} \cdot \sin 41^\circ = 0$$

Since the plank is dragged along the ground, the kinetic friction is given by  $f_k = 0.63 F_N$ , we find for the torque:  $\sum \tau = 138.5 \text{ Nm} - F_N \cdot 3.9 \text{ m} - F_N \cdot 2.2 \text{ m} = 0$  so that the normal force follows

$$F_N = \frac{138.5 \text{ Nm}}{3.9 \text{ m} + 2.2 \text{ m}} = 22.7 \text{ N}.$$

Inserted into the sum of the forces along the horizontal,

$$T_x = 0.63 \cdot 22.7 \text{ N} = 14.3 \text{ N}$$

and along the vertical,

$$T_y = 70.6 \text{ N} - 22.7 \text{ N} = 47.9 \text{ N}.$$

We find the magnitude of the tension in the rope:  $T = \sqrt{T_x^2 + T_y^2}$ , or

$$T = \sqrt{(14.3 \text{ N})^2 + (47.9 \text{ N})^2} = 50.0 \text{ N},$$

and the angle of the rope with respect to the horizontal:  $\tan \phi = T_y/T_x = 47.9 \text{ N}/14.3 \text{ N} = 3.34$

$$\phi = \tan^{-1} 3.34 = 73.4^\circ.$$

**Problem 1.41:** The block has the weight  $mg = 4.2 \text{ kg} \cdot 9.8 \text{ m/s}^2 = 41.2 \text{ N}$ . Because the block is at the center, the forces exerted by the two springs must be equal:

$$F_l = F_r = \frac{41.2 \text{ N}}{2} = 20.6 \text{ N}.$$

Thus the spring constants are

$$k_l = \frac{20.6 \text{ N}}{0.042 \text{ m}} = 490.5 \frac{\text{N}}{\text{m}}, \quad k_r = \frac{20.6 \text{ N}}{0.025 \text{ m}} = 820.0 \frac{\text{N}}{\text{m}}.$$

When the springs are compressed equally  $y_l = y_r = y_0$  then  $F'_l/F'_r = (k_l y_0)/(k_r y_0) = k_l/k_r$ ,

$$\frac{F'_l}{F'_r} = \frac{490.5 \text{ N/m}}{820.0 \text{ N/m}} = 0.6.$$

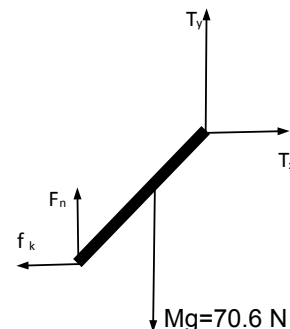

We find  $F_l' = 0.6 \cdot F_r'$  so that  $41.2 \text{ N} = F_l' + F_r' = 0.6 F_r' + F_r' = 1.6 F_r'$ , so that

$$F_r' = \frac{41.2 \text{ N}}{1.6} = 25.8 \text{ N},$$

and

$$F_l' = 0.6 \cdot 25.8 \text{ N} = 15.4 \text{ N}.$$

We move the block to the right by the distance  $d$  from the center. We chose the axis of rotation through the block so that the lever arms are  $0.7 \text{ m} \pm d$ :

$$\begin{aligned} \sum \tau = 0 &= 15.4 \text{ N} \cdot (0.7 \text{ m} + d) - 25.8 \text{ N} \cdot (0.7 \text{ m} - d) \\ &= 10.8 \text{ Nm} - 18.1 \text{ Nm} + 41.2 \text{ N} \cdot d \\ &= -7.3 \text{ Nm} + 41.2 \text{ N} \cdot d \end{aligned}$$

Thus we find the distance,

$$d = \frac{7.3 \text{ Nm}}{41.2 \text{ N}} = 0.18 \text{ m}.$$

**Problem 1.42:** We find the the mechanical energy of the diver running on the spring board:  
 $E_{\text{mech}} = \text{KE} + \text{PE} = mv^2/2 + mgh$ , or

$$E_{\text{mech}} = \frac{1}{2} 56 \text{ kg} \cdot \left(4.5 \frac{\text{m}}{\text{s}}\right)^2 + 56 \text{ kg} \cdot 9.8 \frac{\text{m}}{\text{s}^2} \cdot 10.0 \text{ m} = 6.1 \text{ kJ}.$$

At the highest point, the diver has only gravitational potential energy,  $E_{\text{mech}} = mgh_{\text{max}}$  so that the maximum height above the water follows  $h_{\text{max}} = E_{\text{mech}}/mg$ ,

$$h_{\text{max}} = \frac{6.1 \text{ kJ}}{56 \text{ kg} \cdot 9.8 \text{ m/s}^2} = 11.0 \text{ m}.$$

We consider “initial” when she is at the highest point and “final” when she is temporarily at rest in the water. The total vertical displacement of the diver is  $\Delta y = -12.75 \text{ m}$ . The work by the gravitational force from the highest to the lowest point follows from the change in the gravitational potential energy:  $W_g = -mg\Delta y$

$$W_g = -56 \text{ kg} \cdot 9.8 \frac{\text{m}}{\text{s}^2} \cdot (-12.75 \text{ m}) = 7.0 \text{ kJ}.$$

Since  $v_i = v_f = 0$ , the total work done is zero  $\Delta \text{KE} = W_g + W_{\text{water}} = 0$ , or  $W_{\text{water}} = -W_g$ ,

$$W_{\text{water}} = -7.0 \text{ kJ}.$$

We calculate the work done by the water  $W_{\text{water}} = -f_{\text{water}} \cdot d$  so that the force exerted by the water on the diver is given by  $f_{\text{water}} = W_{\text{water}}/d$

$$f_{\text{water}} = -\frac{(-7.0 \text{ kJ})}{1.75 \text{ m}} = 4.0 \text{ kN}.$$

That’s a force of about 800 lbs. Since  $f_{\text{water}} > 0$ , the force is directed *upwards*.

*Note:* the force exerted by the water on the diver  $f_{\text{water}}$  is analogous to the normal force [“ground reaction force”] exerted by the surface on an object during impact.

**Problem 1.43:** We find the position of the block at  $t = 0$ :  $x(0) = -0.5 \text{ m}$  and the position at time  $t = 2.4 \text{ s}$ :  $x(2.4 \text{ s}) = -0.1 \text{ m}$  so that the velocity follows:

$$v_{\text{ave}} = \frac{-0.1 \text{ m} - (-0.5 \text{ m})}{2.4 \text{ s}} = 0.25 \frac{\text{m}}{\text{s}}.$$

The total distance traveled during the time interval:  $d = 0.5 \text{ m} + 0.5 \text{ m} + 0.6 \text{ m} = 1.6 \text{ m}$  so that

$$\text{average speed} = \frac{1.6 \text{ m}}{2.4 \text{ s}} = 0.67 \frac{\text{m}}{\text{s}}.$$

The block is at turning points at times  $t = 0$  and  $t = 1.6 \text{ s}$ . Since the time between turning points is half of the period, we conclude  $T = 3.2 \text{ s}$ . The angular speed follows:  $\omega = 2\pi/T$ ,

$$\omega \simeq \frac{2\pi}{3.2 \text{ s}} = 2.1 \frac{\text{rad}}{\text{s}}.$$

The amplitude of the oscillatory motion is  $A = 0.5 \text{ m}$ . The maximum speed is given by  $v_{\text{max}} = \omega A$ ,

$$v_{\text{max}} = 2.1 \frac{\text{rad}}{\text{s}} \cdot 0.5 \text{ m} = 1.1 \frac{\text{m}}{\text{s}}.$$

The block travels at the maximum instantaneous velocity at the equilibrium position  $x(t^*) = 0$ . The time follows  $t_* \simeq 0.8 \text{ s}$ . We find the spring constant  $k = m\omega^2$ ,

$$k = 0.75 \text{ kg} \left( 2.1 \frac{\text{rad}}{\text{s}} \right)^2 = 3.3 \frac{\text{N}}{\text{m}}.$$

**Problem 1.44:** The angle of the cable with respect to the horizontal is  $\tan \theta = (1.4 \text{ m})/(0.7 \text{ m}) = 2$  so that  $\theta = 63.4^\circ$ . We find the weight of the table  $W = Mg = 33.3 \text{ N}$ ; the forces from the leg  $F_h$  and  $F_v$  and the tension on the cable  $T$ . Newton's second law yields,

$$\begin{aligned} \sum F_x &= F_h - T \cos 63.4^\circ = 0, \\ \sum F_y &= -T \sin 63.4^\circ + F_v - 33.3 \text{ N} = 0. \end{aligned}$$

We choose the point of contact of the leg with the board as the axis of rotation. Then  $33.3 \text{ N} \cdot 0.25 \text{ m} = 8.3 \text{ Nm}$  is the torque produced by the weight of board. We find

$$\sum \tau = 8.3 \text{ Nm} - T \cdot 0.35 \text{ m} \sin 63.4^\circ = 0.$$

Since  $0.35 \text{ m} \cdot \sin 63.4^\circ = 0.31 \text{ m}$ , we obtain from the torque equation:

$$T = \frac{8.3 \text{ Nm}}{0.31 \text{ m}} = 26.9 \text{ N}.$$

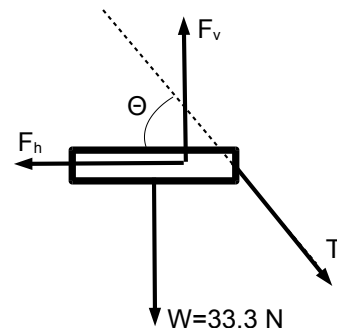

**Problem 1.45:** We calculate the moment of inertia:  $I = 2mR^2$ ,

$$I = 2 \cdot 0.45 \text{ kg} \cdot (0.3 \text{ m})^2 = 0.081 \text{ kg m}^2.$$

The angular displacement is  $\Delta\theta = s/r = 8.6 \text{ cm}/5.0 \text{ cm} = 1.72 \text{ rad}$ . We use equations for (rotational) kinematics:  $\Delta\theta = \alpha t^2/2$  so that the angular acceleration follows  $\alpha = 2\Delta\theta/t^2$ ,

$$\alpha = \frac{2 \cdot 1.72 \text{ rad}}{(0.64 \text{ s})^2} = 8.4 \frac{\text{rad}}{\text{s}^2}.$$

We find the torque from the rotational equation of motion:  $\tau = I\alpha$  so that

$$\tau = 0.081 \text{ kg m}^2 \cdot 8.4 \frac{\text{rad}}{\text{s}^2} = 0.68 \text{ N m}.$$

We thus find the tension  $T = \tau/r$ ,

$$T = \frac{0.68 \text{ N m}}{0.05 \text{ m}} = 13.6 \text{ N}.$$

# INNOVATIVE LIKE YOU.

If you're hoping for a truly modern education, one where you're encouraged to speak your mind and to think long-term, both when it comes to your own future and the future of the planet. Then the University of Gothenburg is the place for you.

Study a Master's programme in Gothenburg, Sweden | [www.gu.se/education](http://www.gu.se/education)



Click on the ad to read more

**Problem 1.46:** We use  $L$  ( $d$ ) for the distance between A and B (B and C). We then find

$$\begin{aligned}L + d &= 17.0 \frac{\text{m}}{\text{s}} \cdot 14.7 \text{ s} = 250.0 \text{ m}, \\L - d &= 9.3 \frac{\text{m}}{\text{s}} \cdot 14.7 \text{ s} = 136.7 \text{ m}.\end{aligned}$$

We add and subtract the two equations and find

$$\begin{aligned}L &= \frac{250.0 \text{ m} + 136.7 \text{ m}}{2} = 193.4 \text{ m}, \\d &= \frac{250.0 \text{ m} - 136.7 \text{ m}}{2} = 56.7 \text{ m}.\end{aligned}$$

We obtain for times  $t_{AB} = L/v_{AB}$  and  $t_{BC} = d/v_{BC}$ , where  $v_{BC} = v_{AB}/2$ . Since  $t_{AB} + t_{BC} = 14.7 \text{ s}$ , we find

$$\frac{193.4 \text{ m}}{v_{AB}} + \frac{56.7 \text{ m}}{v_{BC}} = \frac{193.4 \text{ m}}{v_{AB}} + \frac{2 \cdot 56.7 \text{ m}}{v_{AB}} = 14.7 \text{ s}$$

We obtain the speed from A to B,

$$v_{AB} = \frac{193.4 \text{ m} + 2 \cdot 56.7 \text{ m}}{14.7 \text{ s}} = 20.9 \frac{\text{m}}{\text{s}},$$

and the speed from B to C,  $v_{BC} = v_{AB}/2 = 10.4 \text{ m/s}$ .

**Problem 1.47:** We use  $v_W$  for the velocity of the projectile as it passes by your window and  $t_1$  for the time of the projectile to travel from the window to the highest point. Because the vertical velocity of the projectile at the highest peak is zero  $v = v_W - gt_1 = 0$  so that the speed when the projectile passes by the window:  $v_W = gt_1$ ,

$$v_W = 9.8 \frac{\text{m}}{\text{s}^2} \cdot 2.1 \text{ s} = 20.6 \frac{\text{m}}{\text{s}}.$$

The height of the peak above the window:  $h_p = gt_1^2/2$ ,

$$h_p = \frac{1}{2} 9.8 \frac{\text{m}}{\text{s}^2} \cdot (2.1 \text{ s})^2 = 21.6 \text{ m}.$$

The time from reaching the peak to falling into the river:  $\Delta t = t_2 - t_1 = 11.8 \text{ s} - 2.1 \text{ s} = 9.7 \text{ s}$ . We thus find the height of the peak above the river:  $H_p = g(\Delta t)^2/2$ ,

$$H_p = \frac{1}{2} 9.8 \frac{\text{m}}{\text{s}^2} \cdot \left(9.7 \frac{\text{m}}{\text{s}}\right)^2 = 461.0 \text{ m}.$$

We find the height of the window above the river:  $H_W = H_p - h_p$ ,

$$H_W = 461.0 \text{ m} - 21.6 \text{ m} = 439.4 \text{ m}.$$

**Problem 1.48:** We use  $y = 0$  at the table. Since the center-of-mass of the pencil is at the center of the pencil, we find the initial potential energy:  $E_{\text{mech}} = mgL/2$ ,

$$E_{\text{mech}} = 0.008 \text{ kg} \cdot 9.8 \frac{\text{m}}{\text{s}^2} \cdot \frac{0.16 \text{ m}}{2} = 6.3 \times 10^{-3} \text{ J}.$$

We calculate the final gravitational potential energy:  $PE' = mg(L/2) \cos 30^\circ$ ,

$$PE' = 0.008 \text{ kg} \cdot 9.8 \frac{\text{m}}{\text{s}^2} \cdot \frac{0.16 \text{ m}}{2} \cos 30^\circ = 5.5 \times 10^{-3} \text{ J}$$

We use conservation of mechanical energy:  $E_{\text{mech}} = PE' + KE$  so that the rotational kinetic energy of the pencil is  $KE = PE - PE' = 6.3 \times 10^{-3} \text{ J} - 5.5 \times 10^{-3} \text{ J} = 8.0 \times 10^{-4} \text{ J}$ . Since the kinetic energy is given by  $KE = I\omega_f^2/2$ , we find the angular speed  $\omega_f = \sqrt{2 \cdot KE/I}$ ,

$$\omega_f = \sqrt{\frac{2 \cdot (6.3 \times 10^{-3} \text{ J} - 5.5 \times 10^{-3} \text{ J})}{6.8 \times 10^{-5} \text{ kg m}^2}} = 4.9 \frac{\text{rad}}{\text{s}}.$$

*Note:* The pencil slips at a certain angle away from the vertical, when the coefficient of friction is less than a critical angle.

Sweden  
Sverige

Linköping University –  
innovative, highly ranked,  
European

Interested in Computer Science? Kick-start your career  
with an English-taught master's degree.

→ Click here!

**li.u** LINKÖPING  
UNIVERSITY



**Problem 1.49:** Because  $v = 0$  at the highest point, we find the maximum height when Harry juggles two balls:  $H_2 = g(\Delta t)^2/2$

$$H_2 = \frac{1}{2} 9.8 \frac{\text{m}}{\text{s}^2} (0.35 \text{ s})^2 = 0.60 \text{ m}.$$

We find the launch speed when two balls are juggled:  $v_2 = g\Delta t$

$$v_2 = 9.8 \frac{\text{m}}{\text{s}^2} \cdot 0.35 \text{ s} = 3.4 \frac{\text{m}}{\text{s}}.$$

When one ball is in his hands at  $y = 0$ , then the other two must be at the same height  $y = h$  [which is not the maximum height]. Because free fall is “symmetric” around the peak, the time to reach the highest point is  $\Delta t' = (3/2)\Delta t$ ,

$$\Delta t' = \frac{3}{2} 0.35 \text{ s} = 0.525 \text{ s}$$

We obtain the maximum height of the balls when three balls are juggled:  $H_3 = g(\Delta t')^2/2$ ,

$$H_3 = \frac{1}{2} 9.8 \frac{\text{m}}{\text{s}^2} (0.525 \text{ s})^2 = 1.35 \text{ m}.$$

*That is, the maximum height more than doubles!* Since  $H_3 = (v_3)^2/2g$ , we find the speed of the ball when juggling three balls:  $v_3 = \sqrt{2gH_3}$ :

$$v_3 = \sqrt{2 \cdot 9.8 \frac{\text{m}}{\text{s}^2} \cdot 1.35 \text{ m}} = 5.1 \frac{\text{m}}{\text{s}}.$$

The height of the two balls in air follows:  $y = v_3 \cdot \Delta t - g(\Delta t)^2/2$  or

$$y = 5.1 \frac{\text{m}}{\text{s}} \cdot 0.35 \text{ s} - \frac{1}{2} 9.8 \frac{\text{m}}{\text{s}^2} \cdot (0.35 \text{ s})^2 = 1.20 \text{ m}.$$

*Note:* Our calculation shows why juggling two balls is easy but quite difficult for three balls!

**Problem 1.50:** We introduce the horizontal and vertical components of the tensions in the strings  $T_h$  and  $T_v$ . The net force on the object is zero:

$$\begin{aligned} T_{1,h} &= 28 \text{ N} \cdot \cos 52^\circ = 17.2 \text{ N}, \\ T_{1,v} &= 28 \text{ N} \cdot \sin 52^\circ = 22.1 \text{ N}. \end{aligned}$$

We find  $T_{2,h} = -17.2 \text{ N} = -T_2 \cdot \cos 22^\circ$  so that

$$T_2 = \frac{17.2 \text{ N}}{\cos 22^\circ} = 18.6 \text{ N}.$$

The vertical component follows  $T_{2,v} = 18.6 \text{ N} \cdot \sin 22^\circ = 7.0 \text{ N}$ . Thus, we find the weight  $W = T_{1,v} + T_{2,v}$

$$W = 22.1 \text{ N} + 7.0 \text{ N} = 29.1 \text{ N}.$$

We find  $W' = 29.1 \text{ N} + 12.0 \text{ N} = 41.1 \text{ N}$ . The two equations for unknown tensions  $T'_1$  and  $T'_2$  follow:

$$\begin{aligned} 0.61 T'_1 - 0.93 T'_2 &= 0 \\ 0.79 T'_1 + 0.37 T'_2 &= 41.1 \text{ N}. \end{aligned}$$

From the first equation:  $T'_2 = (0.61/0.93)T'_1 = 0.66T'_1$ . Thus

$$0.79T'_1 + 0.37 \cdot 0.66 T'_1 = 1.03 T'_1 = 41.1 \text{ N},$$

so that for the tension  $T'_1$ ,

$$T'_1 = \frac{41.1 \text{ N}}{1.03} = 39.7 \text{ N},$$

and for the tension  $T'_2$ ,

$$T'_2 = 0.66 \cdot 39.7 \text{ N} = 26.2 \text{ N}.$$

**Problem 1.51:** When the block passes through vertical, the forces on the bob are the tension  $T = 23.1 \text{ N}$  and the weight  $mg = 0.7 \text{ kg} \cdot 9.8 \text{ m/s}^2 = 6.9 \text{ N}$ . Thus, the net force on the bob follows:

$$F_{\text{net}} = 11.3 \text{ N} - 6.9 \text{ N} = 4.4 \text{ N}.$$

Since the bob undergoes circular motion, the acceleration of the bob follows  $a_c = v_{\text{max}}^2/l$ . Thus, Newton's second law for the bob yields:  $F_{\text{net}} = ma_c = mv_{\text{max}}^2/l$ . We find the speed  $v_{\text{max}}$  when the bob passes through the vertical  $v = \sqrt{F_{\text{net}}l/m}$ ,

$$v_{\text{max}} = \sqrt{\frac{0.91 \text{ m} \cdot 4.4 \text{ N}}{0.7 \text{ kg}}} = 2.4 \frac{\text{m}}{\text{s}}.$$

We use the coordinate  $x$  ( $y$ ) along the horizontal (vertical). The components of the velocity when the bob is released,  $v_{x,i} = 0$  and  $v_{y,i} = 0$ , and when it swings through the vertical,  $v_{x,f} = -v_{\text{max}} = -2.4 \text{ m/s}$  and  $v_{y,f} = 0$ . We find the impulse along the vertical  $J_y = m\Delta v_y = 0$  and along the horizontal  $J_x = m\Delta v_x$ ,

$$J_x = 0.7 \text{ kg} \cdot \left(-2.4 \frac{\text{m}}{\text{s}}\right) = -1.7 \frac{\text{kg m}}{\text{s}}.$$

The time to reach the vertical is a quarter of the period  $t = T/4 = (2\pi/4)\sqrt{l/g}$ ,

$$\Delta t = \frac{\pi}{2} \sqrt{\frac{0.91 \text{ m}}{9.8 \text{ m/s}^2}} = 0.48 \text{ s}.$$

The average force acting on the bob follows  $F_{x,\text{ave}} = J_x/\Delta t$ ,

$$F_{x,\text{ave}} = \frac{-1.7 \text{ kg m/s}}{0.48 \text{ s}} = -3.5 \text{ N},$$

and  $F_{y,\text{ave}} = 0$ .

**Problem 1.52:** Potential energy is converted into kinetic energy when the egg falls to the ground:  $mgh = mv^2/2$  so that  $v = \sqrt{2gh} = \sqrt{2 \cdot 9.8 \text{ m/s}^2 \cdot 4.7 \text{ m}} = 9.6 \text{ m/s}$ . Thus for the momentum when right before the egg hits the ground  $p = mv$ ,

$$p = 0.057 \text{ kg} \cdot 9.6 \frac{\text{m}}{\text{s}} = 0.55 \frac{\text{kg m}}{\text{s}}.$$



We now consider the ‘collision’ of the egg with the ground. The initial momentum is given by  $p_i = 0.55 \text{ kg} \cdot \text{m/s}$ . Since the egg comes to a full stop,  $p_f = 0$ . We find the net force from the change in momentum:  $F_{\text{net}} = \Delta p / \Delta t$ ,

$$F_{\text{net}} = \frac{0 - 0.55 \text{ kg m/s}}{0.020 \text{ s}} = -27.5 \text{ N}.$$

We find the “ground reaction force,”  $F_{\text{net}} = F_{\text{ground}} + mg$  so that

$$F_{\text{ground}} = -27.5 \text{ N} - 0.057 \text{ kg} \cdot 9.8 \frac{\text{m}}{\text{s}^2} = -28.0 \text{ N}.$$

Here, the negative sign means that the force is directed *upwards*. We calculate the indentation from the work done by the ground reaction force. We find the initial kinetic energy  $\text{KE}_i = (0.057 \text{ kg} \cdot (9.6 \text{ m/s})^2)^{1/2} = 2.6 \text{ J}$ . Since the  $\text{KE}_f = 0$ , we find the work done by the net force from the work - kinetic energy theorem:  $W = \Delta \text{KE} = \text{KE}_f - \text{KE}_i = 0 - 2.6 \text{ J} = -2.6 \text{ J}$ . Work is done while the package is compressed:  $W = F_{\text{net}} \Delta y$ . We solve for the compression  $\Delta y = W / F_{\text{net}}$ ,

$$\Delta y = \frac{-2.6 \text{ J}}{-28.0 \text{ N}} = 0.09 \text{ m},$$

or about  $\Delta y = 9 \text{ cm}$ .

**STUDY FOR YOUR MASTER'S DEGREE  
IN THE CRADLE OF SWEDISH ENGINEERING**

Chalmers University of Technology conducts research and education in engineering and natural sciences, architecture, technology-related mathematical sciences and nautical sciences. Behind all that Chalmers accomplishes, the aim persists for contributing to a sustainable future – both nationally and globally.

Visit us on **Chalmers.se** or **Next Stop Chalmers** on facebook.

**CHALMERS**  
UNIVERSITY OF TECHNOLOGY



**Problem 1.53:** We use  $y = 0$  at the height of the table, so that the total mechanical energy of the system is  $E_{\text{mech},0} = \text{KE}_0 + \text{PE}_0 = 0$ . Then the vertical displacement is  $y = -0.36$  m, and the change in potential energy follows:

$$\Delta\text{PE} = -1.7 \text{ kg} \cdot 9.8 \frac{\text{m}}{\text{s}^2} \cdot 0.31 \text{ m} = -5.2 \text{ J}.$$

Since  $m_1 + m_2 = 2.3 \text{ kg} + 1.7 \text{ kg} = 4.0 \text{ kg}$ , the conservation of mechanical energy then yields for the speed  $v$ :  $E_{\text{mech}} = 0 = -5.2 \text{ J} + 4.0 \text{ kg } v^2/2$ , so that the speed follows

$$v = \sqrt{\frac{2 \cdot 5.2 \text{ J}}{4.0 \text{ kg}}} = 1.61 \frac{\text{m}}{\text{s}}.$$

Forces on block  $m_1$  are weight (vertical), normal force (vertical), and tension (horizontal). Since the displacement of the block is along the horizontal, the weight and normal forces do zero work. The work by the tension follows from the work-kinetic energy theorem:  $W_{T,1} = \Delta\text{KE}_1$ ,

$$W_{T,1} = \frac{2.3 \text{ kg}}{2} \left(1.61 \frac{\text{m}}{\text{s}}\right)^2 = 3.0 \text{ J}.$$

Forces are the weight and the tension. We now consider the hanging block only. The work done by the weight is given by  $W_{g,2} = -\Delta\text{PE}$ ,

$$W_{g,2} = -(-5.2 \text{ J}) = 5.2 \text{ J}.$$

Since  $\Delta\text{KE}_2 = W_g + W_{T,2}$ , we find the work done by the tension,  $W_{T,2} = \Delta\text{KE}_2 - W_{g,2}$ ,

$$W_{T,2} = \frac{1.7 \text{ kg}}{2} \left(1.61 \frac{\text{m}}{\text{s}}\right)^2 - 5.2 \text{ J} = -3.0 \text{ J}.$$

Note that  $W_{T,1} = -W_{T,2}$ . Since  $|W_T| = Td$ , we find the tension in the string:  $T = |W_T|/d$ ,

$$T = \frac{3.0 \text{ J}}{0.31 \text{ m}} = 9.7 \text{ N}.$$

**Problem 1.54:** We write the sum of the forces:  $\sum F_y = F_N - 22.5 \text{ N} = 0$  so that  $F_N = 22.5 \text{ N}$ . The maximum friction follows  $f_{s,\text{max}} = \mu_s F_N = 0.13 \cdot 22.5 \text{ N} = 2.9 \text{ N}$ . Newton's second law for the spool along the horizontal:

$$\sum F_x = F - f_s = 2.3 \text{ kg} \cdot a$$

and Newton's second for the rotation about the center:

$$\sum \tau = f_s \cdot 0.06 \text{ m} = 0.0054 \text{ kg m}^2 \cdot \alpha$$

The angular acceleration follows  $\alpha = \sum \tau/I$ . Because the spool rolls without slipping, the linear acceleration follows  $a = \alpha r$  so that

$$a = \frac{2.9 \text{ N} \cdot (0.06 \text{ m})^2}{0.0054 \text{ kg m}^2} = 1.9 \frac{\text{m}}{\text{s}^2},$$

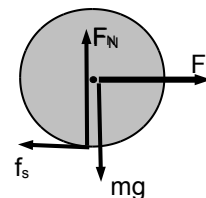

and the pull force follows

$$F = 2.9 \text{ N} + 2.3 \text{ kg} \cdot 1.9 \frac{\text{m}}{\text{s}^2} = 7.3 \text{ N}.$$

We now pull on the inner cylinder. We find the sum of the forces along the horizontal  $\sum F_x = F' + f_s = 2.3 \text{ kg} \cdot a$ . Since the maximum friction force is the same as above, Newton's second law yields

$$\sum F_x = F' + 2.9 \text{ N} = 2.3 \text{ kg} \cdot a$$

and Newton's second law for the rotation about the center:

$$\sum \tau = F' \cdot 0.048 \text{ m} - f_s \cdot 0.06 \text{ m} = 0.0054 \text{ kg m}^2 \cdot \alpha$$

Since  $0.0054 \text{ kg m}^2 / (0.06 \text{ m})^2 = 1.5 \text{ kg}$ . We obtain  $F' (0.048 \text{ m} / 0.06 \text{ m}) - 2.9 \text{ N} = 1.5 \text{ kg} \cdot a$  so that

$$0.8 F' - 2.9 \text{ N} = 1.5 \text{ kg } a$$

We add the two equations:  $1.8 F' = 3.8 \text{ kg} \cdot a$  so that the linear acceleration follows  $a = 1.8 F' / 3.8 \text{ kg}$  and  $F' + 2.9 \text{ N} = 2.3 \text{ kg} \cdot (1.8 F' / 3.8 \text{ kg}) = 1.09 F'$ . We find the maximum pull

$$F' = \frac{2.9 \text{ N}}{0.09} = 32.2 \text{ N}.$$

The corresponding acceleration follows

$$a = \frac{1.8 \cdot 32.2 \text{ N}}{3.8 \text{ kg}} = 15.3 \frac{\text{m}}{\text{s}^2}.$$

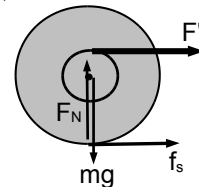

**Problem 1.55:** Since  $\omega = 2\pi/T$ , we find the angular frequency from the period,  $\omega = 2\pi \text{ rad} / 1.2 \text{ s} = 5.2 \text{ rad/s}$ . The initial speed of the block is equal to the maximum speed when it passes through the equilibrium position. Because the maximum speed is determined by the amplitude and angular frequency, we find  $v_0 = v_{\text{max}} = \omega A$ ,

$$v_{\text{max}} = 5.2 \frac{\text{rad}}{\text{s}} \cdot 0.15 \text{ m} = 0.78 \frac{\text{m}}{\text{s}}.$$

When the clay is on the block, the period is longer,  $\omega' = 2\pi/T' = 2\pi \text{ rad} / 1.4 \text{ s} = 4.5 \text{ rad/s}$ . Then for the ratio:  $(\omega/\omega')^2 = (5.2 \text{ Hz} / 4.5 \text{ Hz})^2 = 1.33$ . Since  $(\omega/\omega')^2 = (k/m) / (k/[m + M]) = (m + M)/m$ , we find

$$1.33 = 1 + \frac{M}{m}.$$

We find the mass of clay

$$M = 0.33 \cdot 1.5 \text{ kg} = 0.5 \text{ kg}.$$

Linear momentum is conserved when the piece of clay with mass  $M$  falls on top of block  $m$  so that  $mv_{\text{max}} = (M + m)v'_{\text{max}}$ . We solve for the maximum speed of the block with the clay on top:  $v'_{\text{max}} = (m/[m + M])v_{\text{max}}$ ,

$$v'_{\text{max}} = \frac{1.5 \text{ kg}}{2.0 \text{ kg}} \cdot 0.78 \frac{\text{m}}{\text{s}} = 0.58 \frac{\text{m}}{\text{s}}$$

We now use  $v'_{\text{max}} = \omega' A'$  so that  $A' = v'_{\text{max}} / \omega'$

$$A' = \frac{0.58 \text{ m/s}}{4.5 \text{ rad/s}} = 0.13 \text{ m}.$$

**Problem 1.56:** We draw the free body-diagram for the box. We choose a coordinate along and perpendicular to the incline. The components of the weight  $mg = 14 \text{ kg} \cdot 9.8 \text{ m/s}^2 = 137.2 \text{ N}$  are given by

$$W_x = 137.2 \text{ N} \cdot \cos 17^\circ = 131.2 \text{ N},$$

$$W_y = 137.2 \text{ N} \cdot \sin 17^\circ = 40.1 \text{ N}.$$

Newton's second law for the box follows:

$$\sum F_x = -f_s + 40.1 \text{ N} = 0,$$

$$\sum F_y = F_{N,1} + F_{N,2} - 131.2 \text{ N} = 0.$$

Thus, the static friction follows

$$f_s = 40.1 \text{ N}.$$

We choose the front leg as the axis of rotation. The torque produced by the weight of the box follows

$$\tau_{\text{box}} = 137.2 \text{ N} \cdot \frac{\sqrt{(0.26 \text{ m})^2 + (0.12 \text{ m})^2}}{2} \cdot \cos(24.8^\circ + 17^\circ) = 14.7 \text{ Nm}.$$

The total torque about the axis of rotation follows:

$$\sum \tau = -F_{N,2} \cdot 0.26 \text{ m} + 14.7 \text{ Nm} = 0.$$

The normal force on the back leg follows

$$F_{N,2} = \frac{14.7 \text{ Nm}}{0.26 \text{ m}} = 56.4 \text{ N}.$$

We then find the normal force on the front leg:

$$F_{N,1} = 131.2 \text{ N} - 56.4 \text{ N} = 74.8 \text{ N}.$$

When the block begins the slide, the static friction is equal to the maximum value  $f_{s,\text{max}} = \mu_s F_{N,1}$ . We write Newton's second law:

$$\sum F_x = -0.7 \cdot F_{N,1} + 137.2 \text{ N} \cdot \sin \phi_{\text{max}} = 0,$$

$$\sum F_y = F_{N,1} + F_{N,2} - 137.2 \text{ N} \cdot \cos \phi_{\text{max}} = 0.$$

The normal force on the front leg follows:

$$F_{N,1} = 196 \text{ N} \cdot \sin \phi_{\text{max}}.$$

We find the torque about the front leg:

$$\sum \tau = -F_{N,2} \cdot 0.26 \text{ m} + 19.64 \text{ Nm} \cdot \cos(24.8^\circ + \phi_{\text{max}}) = 0.$$

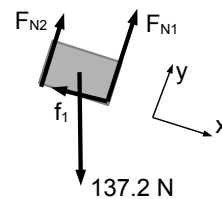

Thus, the normal force on the back leg can be written in terms of the maximum angle  $\phi_{\max}$ :

$$F_{N,2} = 75.5 \text{ N} \cdot \cos(24.8^\circ + \phi_{\max})$$

Inserted into equation for  $\sum F_y = 0$ :

$$196 \text{ N} \sin \phi_{\max} + 75.5 \text{ N} \cos(24.8^\circ + \phi_{\max}) - 137.2 \text{ N} \cos \phi_{\max} = 0$$

We use  $\cos(24.8^\circ + \phi_{\max}) = \cos 24.8^\circ \cos \phi_{\max} - \sin 24.8^\circ \sin \phi_{\max}$  and find after some algebra

$$\tan \phi_{\max} = \frac{68.5 \text{ N}}{164.3 \text{ N}} = 0.42,$$

so that the maximum angle of the incline follows  $\phi_{\max} = 23^\circ$ .

**MÄLARDALEN UNIVERSITY**  
SWEDEN

**WELCOME TO  
OUR WORLD  
OF TEACHING!**  
INNOVATION, FLAT HIERARCHIES  
AND OPEN-MINDED PROFESSORS

**STUDY IN SWEDEN -  
CLOSE COLLABORATION  
WITH FUTURE EMPLOYERS**  
MÄLARDALEN UNIVERSITY COLLABORATES WITH  
MANY EMPLOYERS SUCH AS ABB, VOLVO AND  
ERICSSON

**TAKE THE  
RIGHT TRACK**  
GIVE YOUR CAREER A HEADSTART AT MÄLARDALEN UNIVERSITY  
[www.mdh.se](http://www.mdh.se)

**DEBAJYOTI NAG**  
SWEDEN, AND PARTICULARLY  
MDH, HAS A VERY IMPRES-  
SIVE REPUTATION IN THE FIELD  
OF EMBEDDED SYSTEMS RE-  
SEARCH, AND THE COURSE  
DESIGN IS VERY CLOSE TO THE  
INDUSTRY REQUIREMENTS.  
HE'LL TELL YOU ALL ABOUT IT AND  
ANSWER YOUR QUESTIONS AT  
[MDUSTUDENT.COM](http://MDUSTUDENT.COM)

**Problem 1.57:** The initial angular speed of the Yo-Yo is zero  $\omega_0 = 0$ . Since the Yo-Yo rolls without slipping, we find the final angular speed from the final linear speed:  $\omega_f = v/r$ ,

$$\omega_f = \frac{0.6 \text{ m/s}}{0.08 \text{ m}} = 7.5 \frac{\text{rad}}{\text{s}}.$$

We obtain the angular displacement  $\Delta\theta = h/r = 0.20 \text{ m}/0.08 \text{ m} = 2.5 \text{ rad}$ . Since  $\omega^2 = 2\alpha\Delta\theta$ , we find the angular acceleration:  $\alpha = \omega^2/2\Delta\theta$ ,

$$\alpha = \frac{(7.5 \text{ rad/s})^2}{2 \cdot 2.5 \text{ rad}} = 11.25 \frac{\text{rad}}{\text{s}^2}.$$

At the start, the Yo-Yo has gravitational potential energy:  $\text{PE}_i = mgh$ ,

$$\text{PE}_i = 0.24 \text{ kg} \cdot 9.8 \frac{\text{m}}{\text{s}^2} \cdot 0.20 \text{ m} = 0.47 \text{ J}.$$

The gravitational energy is transformed into kinetic energy for both translation and rotation. Since the translational kinetic energy is

$$\text{KE}_{\text{trans}} = \frac{1}{2} 0.24 \text{ kg} \cdot \left(0.6 \frac{\text{m}}{\text{s}}\right)^2 = 0.04 \text{ J},$$

the rotational kinetic energy follows:  $\text{KE}_{\text{rot}} = \text{PE} - \text{KE}_{\text{trans}}$ ,

$$\text{KE}_{\text{rot}} = 0.47 \text{ J} - 0.04 \text{ J} = 0.43 \text{ J}.$$

Since  $\text{KE}_{\text{rot}} = I\omega_f^2/2$ , we find the moment of inertia  $I = 2\text{KE}_{\text{rot}}/\omega_f^2$ ,

$$I = \frac{2 \cdot 0.43 \text{ J}}{(7.5 \text{ rad/s})^2} = 1.53 \times 10^{-2} \text{ kg m}^2$$

The torque about the center of the Yo-Yo then follows  $\tau = I\alpha$ ,

$$\tau = 1.53 \times 10^{-2} \text{ kg m}^2 \cdot 11.25 \frac{\text{rad}}{\text{s}^2} = 0.17 \text{ N m}.$$

The torque is produced by the tension in the string  $\tau = Tr$  so that  $T = \tau/r$ ,

$$T = \frac{0.17 \text{ N m}}{0.08 \text{ m}} = 2.2 \text{ N}.$$

**Problem 1.58:** For uniform harmonic motion, the maximum acceleration is determined by the angular frequency  $\omega$  and the amplitude,  $a_{\text{max}} = \omega^2 A$ . Since the object is dropped at the surface of the Earth, the Earth radius is equal to the amplitude of the harmonic motion:  $A = R_E$ . The maximum acceleration of the object is equal to the acceleration due to gravity:  $a_{\text{max}} = g$ . We find  $\omega = \sqrt{g/R_E}$ ,

$$\omega = \sqrt{\frac{9.8 \text{ m/s}^2}{6.38 \times 10^6 \text{ m}}} = 1.24 \times 10^{-3} \frac{\text{rad}}{\text{s}}$$

The period follows  $T = 2\pi/\omega$ ,

$$T = \frac{2\pi \text{ rad}}{1.24 \times 10^{-3} \text{ rad/s}} = 84.5 \text{ min.}$$

The time to re-appear on the other side of the Earth is half a period:  $t^* = T/2$ ,

$$t^* = 42.25 \text{ min.}$$

For harmonic motion, the object has maximum speed when it goes through the equilibrium position, that is, when it is at the center of the Earth for this case. The maximum speed is determined by the amplitude and angular frequency,  $v_{\max} = \omega A = \omega R_E$ ,

$$v_{\max} = 1.24 \times 10^{-3} \frac{\text{rad}}{\text{s}} \cdot 6.38 \times 10^6 \text{ m} = 7.9 \times 10^3 \frac{\text{m}}{\text{s}}.$$

We compare with uniform circular motion very close to the Earth surface. Since the gravitational acceleration is equal to the centripetal acceleration, we find  $g = v_{\text{orbit}}^2/R_E$ , so that the orbital speed follows  $v_{\text{orbit}} = \sqrt{gR_E}$ ,

$$v_{\text{orbit}} = \sqrt{9.8 \frac{\text{m}}{\text{s}^2} \cdot 6.38 \times 10^6 \text{ m}} = 7.9 \times 10^3 \frac{\text{m}}{\text{s}}.$$

This is the same as the answer in part **b**). We find the period of orbit:

$$T = \frac{2\pi R_E}{v_{\text{orbit}}} = \frac{2\pi \cdot 6.38 \times 10^6 \text{ m}}{7.9 \times 10^3 \text{ m/s}} = 84.5 \text{ min,}$$

so that  $t = T/2 = 42.25 \text{ min}$ . This is the same result as in part **a**).

*Note:* We find the same results for the harmonic motion inside the tunnel through the center of the Earth and the motion of a satellite close to the Earth surface. It reflects the connection between simple harmonic motion and motion on the reference circle.

**Problem 1.59:** We follow the block backwards in time: we first examine the sliding up the incline (phase II) and then we consider the collision of bullet with the stationary block (phase I). Phase II: We choose a coordinate system  $x$  down the incline. The net force is the component of the weight parallel to the incline  $F_{\text{net}} = (M + m)g \sin \theta = 0.823 \text{ kg} \cdot 9.8 \text{ m/s}^2 \cdot \sin 28^\circ = 3.8 \text{ N}$ . The impulse follows  $J = F_{\text{net}} \Delta t$ ,

$$J = 3.66 \text{ N} \cdot 4.2 \text{ s} = 16.1 \frac{\text{kg m}}{\text{s}}.$$

Since the block comes to a full stop  $v_{\text{II},f} = 0$  so that  $J = \Delta p = mv_{\text{II},f} - (M + m)v_{\text{II},i} = -(M + m)v_{\text{II},i}$  so that the initial speed of the block follows  $v_{\text{II},i} = -J/(M + m)$ ,

$$v_{\text{II},i} = -\frac{15.4 \text{ kg m/s}}{0.823 \text{ kg}} = -19.3 \frac{\text{m}}{\text{s}}.$$

Here, the negative sign means that the block travels up the incline. The initial velocity for phase II is equal to the final velocity in phase I:  $v_{\text{II},i} = v_{\text{I},f} = -19.3 \text{ m/s}$ . The process of the bullet entering the block can be treated as an inelastic collision. Thus, the conservation of linear momentum yields  $mV = (M + m)v_{\text{I},f}$ , or  $V = ([M + m]/m)v_{\text{I},f}$ ,

$$V = \frac{0.823 \text{ kg}}{0.023 \text{ kg}} \cdot \left(-19.3 \frac{\text{m}}{\text{s}}\right) = -691 \frac{\text{m}}{\text{s}}.$$

We obtain the initial kinetic energy:  $\text{KE}_{I,i} = mV^2/2$

$$\text{KE}_{I,i} = \frac{1}{2} 0.023 \text{ kg} \cdot \left(644 \frac{\text{m}}{\text{s}}\right)^2 = 5.49 \text{ kJ},$$

and the final kinetic energy:  $\text{KE}_{I,f} = (M + m)v_f^2/2$ ,

$$\text{KE}_{I,f} = \frac{1}{2} 0.823 \text{ kg} \cdot \left(19.3 \frac{\text{m}}{\text{s}}\right)^2 = 0.15 \text{ kJ}.$$

The dissipated energy:  $E_{\text{nc}} = -W_{\text{nc}} = \text{KE}_{I,i} - \text{KE}_{I,f}$ ,

$$E_{\text{nc}} = 5.49 \text{ kJ} - 0.15 \text{ kJ} = 5.34 \text{ kJ},$$

and the fraction of energy lost:

$$\chi = \frac{E_{\text{nc}}}{\text{KE}_{I,i}} = \frac{5.34 \text{ kJ}}{5.49 \text{ kJ}} = 0.97,$$

or about 97%.



UPPSALA  
UNIVERSITET

## Develop the tools we need for Life Science Masters Degree in Bioinformatics

Bioinformatics is the exciting field where biology, computer science, and mathematics meet.

We solve problems from biology and medicine using methods and tools from computer science and mathematics.

Read more about this and our other international masters degree programmes at [www.uu.se/master](http://www.uu.se/master)





**Problem 1.60:** Newton's second law for the two blocks yields:

$$\begin{aligned} \sum F_y &= F_{N,1} - m_1g = 0, & \sum F_x &= T = m_1a_1, \\ \sum F_y &= F_{N,2} - m_2g = 0, & \sum F_x &= T' - T = m_2a_2. \end{aligned}$$

We find the centripetal acceleration of the outer block:  $a_2 = T_{\max}/m_2$ ,

$$a_2 = \frac{74.0 \text{ N}}{1.75 \text{ kg}} = 42.3 \frac{\text{m}}{\text{s}^2}.$$

Since the block undergo uniform circular motion, the acceleration  $a_2$  depends on the speed of the block  $m_2$  and the radius  $L_1 + L_2$ :  $a_2 = v_2^2/(L_1 + L_2)$ , so that  $v_2 = \sqrt{a_2(L_1 + L_2)}$ ,

$$v_2 = \sqrt{42.3 \frac{\text{m}}{\text{s}^2} \cdot (1.6 \text{ m} + 0.4 \text{ m})} = 9.2 \frac{\text{m}}{\text{s}}.$$

The period is the same for the two blocks. Since the period is given by  $T = 2\pi L_1/v_1 = 2\pi(L_1 + L_2)/v_2$ , we find  $v_1 = (L_1/[L_1 + L_2])v_2$ ,

$$v_1 = \frac{1.6 \text{ m}}{1.6 \text{ m} + 0.4 \text{ m}} 9.2 \frac{\text{m}}{\text{s}} = 7.4 \frac{\text{m}}{\text{s}}.$$

The acceleration of the block  $m_1$  follows  $a_1 = v_1^2/L_1$ ,

$$a_1 = \frac{(7.4 \text{ m/s})^2}{1.6 \text{ m}} = 33.8 \frac{\text{m}}{\text{s}^2}.$$

Newton's second law for  $m_1$  shows  $T' - T_{\max} = m_1a_1$ , or  $T' = T_{\max} + m_1a_1$ ,

$$T' = 74.0 \text{ N} + 1.75 \text{ kg} \cdot 33.8 \frac{\text{m}}{\text{s}^2} = 133.3 \text{ N}.$$

**Problem 1.61:** The forces acting on the box are the weight  $mg = 15.3 \text{ kg} \cdot 9.8 \text{ m/s}^2 = 150.0 \text{ N}$ , the normal force  $F_N$ , and the static friction  $f_s$ . We write Newton's second law for the box:

$$\begin{aligned} \sum F_x &= f_s = 15.3 \text{ kg} \cdot a, \\ \sum F_y &= F_N - 150.0 \text{ N} = 0. \end{aligned}$$

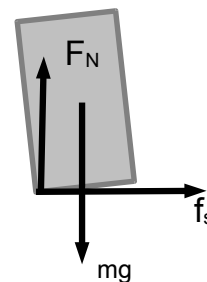

We thus find the normal force  $F_N = 150 \text{ N}$ . We choose the center of the box as the axis of rotation. The torque produced by the normal force follows  $\tau_N = 150 \text{ N} \cdot 0.73 \text{ m}/2 = 54.8 \text{ Nm}$ . We write the torque about the center of mass of the box:

$$\sum \tau = f_s \cdot \frac{3.2 \text{ m}}{2} - 54.8 \text{ Nm} = 0.$$

We find the static friction force:  $f_s = 54.8 \text{ Nm}/1.6 \text{ m} = 34.2 \text{ N}$ , and then obtain the maximum acceleration:  $a = f_s/m$ ,

$$a_{\max} = \frac{34.2 \text{ N}}{15.3 \text{ kg}} = 2.24 \frac{\text{m}}{\text{s}}.$$

Since  $f_s < f_{\max} = \mu_s F_N$ , we find the condition for the coefficient of static friction:

$$\mu_s > \frac{34.2 \text{ N}}{150.0 \text{ N}} = 0.228.$$

**Problem 1.62:** We find the period of the satellite  $T = 24 \text{ h} = 86,400 \text{ s}$ . Then the angular frequency follows  $\omega = 2\pi/T = 3.03 \times 10^{-6} \text{ s}^{-1}$ . We express the universal gravitational constant in terms of more familiar quantities. The gravitational acceleration on the Earth's surface is determined by the Earth's mass and radius  $g = GM_E/R_E^2$  so that  $G = gR_E^2/M_E$ . We then write for the gravitational acceleration at the radius  $R$ :

$$\frac{GM_E}{R^2} = g \left( \frac{R_E}{R} \right)^2 = \omega^2 R$$

so that  $R = (gR_E^2/\omega^2)^{1/3}$ ,

$$R = \left( \frac{9.8 \text{ m/s}^2 \cdot 6.38 \times 10^6 \text{ m}}{(3.03 \times 10^{-6} \text{ s}^{-1})^2} \right)^{1/3} = 351,000 \text{ km}.$$

That's about 345,000 km from the Earth surface; or about 10% of the distance to the Moon. When  $R = R_E$ , we write the acceleration due to gravity  $g = \Omega^2 R_E$ , or  $\Omega = \sqrt{g/R_E}$ ,

$$\Omega = \sqrt{\frac{9.8 \text{ m/s}^2}{6.38 \times 10^6 \text{ m}}} = 1.24 \times 10^{-3} \text{ s}^{-1}.$$

We find the period of the satellite:  $T_{\text{satellite}} = 2\pi/\Omega \simeq 5070 \text{ s} \simeq 85 \text{ min}$ . If we ignore the rotation of the Earth, the satellite would orbit the Earth about 18 times every day.

**Problem 1.63:** The speed of the water as it leaves the gun is given by  $v_{\text{gun}} = \sqrt{2gH_{\max}}$ ,

$$v_{\text{gun}} = \sqrt{2 \cdot 9.8 \frac{\text{m}}{\text{s}^2} \cdot 30.5 \text{ m}} = 24.5 \text{ m/s}.$$

The total mass of the system (Harry, all the water and the cart) is  $M = 68.45 \text{ kg}$ . Initially everything is at rest so that from the conservation of momentum:

$$0 = -0.35 \text{ kg} \cdot 24.5 \frac{\text{m}}{\text{s}} + (68.45 \text{ kg} - 0.35 \text{ kg}) \cdot v_1.$$

Since  $0.35 \text{ kg} \cdot 24.5 \text{ m/s} = 8.58 \text{ kg m/s}$ , we find the velocity after the first squirt:

$$v_1 = \frac{8.58 \text{ kg m/s}}{68.1 \text{ kg}} = 0.13 \frac{\text{m}}{\text{s}}.$$

We repeat for the second squirt of the gun:

$$68.1 \text{ kg} \cdot 0.13 \frac{\text{m}}{\text{s}} = -0.35 \text{ kg} \cdot 24.5 \frac{\text{m}}{\text{s}} + (68.1 \text{ kg} - 0.35 \text{ kg}) v_2.$$

Thus the velocity after the second squirt:

$$v_2 = \frac{2 \cdot 8.58 \text{ kg m/s}}{67.75 \text{ kg}} = 0.25 \frac{\text{m}}{\text{s}}.$$

We obtain the same result whether we squirt 0.35 kg twice or  $2 \cdot 0.35 \text{ kg} = 0.70 \text{ kg}$  at once. The number of squirts is  $N = 15.05 \text{ kg}/0.35 \text{ kg} = 43$ . We empty the water tank all at once:

$$0 = -15.05 \text{ kg} \cdot 20.5 \frac{\text{m}}{\text{s}} + (45.0 \text{ kg} + 8.4 \text{ kg}) v_{43}.$$

Thus the velocity after 43 squirts:

$$v_{43} = \frac{15.05 \text{ kg}}{53.4 \text{ kg}} \cdot 24.5 \frac{\text{m}}{\text{s}} = 6.91 \frac{\text{m}}{\text{s}}.$$

Note that  $v_{43} > 43 v_1$ . The necessary time follows

$$\Delta t = \frac{43}{12} 60 \text{ s} = 215 \text{ s}.$$

We calculate the total work done on the ‘Harry+cart’ from the change in kinetic energy,  $W_{\text{total}} = \Delta \text{KE}$ ,

$$W_{\text{total}} = \frac{1}{2} (45 \text{ kg} + 8.4 \text{ kg}) \cdot \left(6.9 \frac{\text{m}}{\text{s}}\right)^2 = 1271 \text{ J}$$

The average power follows  $P = W_{\text{total}}/\Delta t$ ,

$$P = \frac{1271 \text{ J}}{215 \text{ s}} = 5.9 \text{ W}.$$

*Note:* There are other possible values of power since it is not constant.

**Problem 1.64:** The tower is the peak of the trajectory. The vertical displacement when the ball just clears the wall:  $\Delta y = 5.9 \text{ m} - 7.3 \text{ m} = -1.4 \text{ m}$ . Since the ball is in free-fall along the vertical, we find  $\Delta y = -gt_w^2/2$ . The time to reach the wall follows:  $t_w = \sqrt{-2\Delta y/g}$ ,

$$t_w = \sqrt{-\frac{2 \cdot (-1.4 \text{ m})}{9.8 \text{ m/s}^2}} = 0.53 \text{ s}.$$

The horizontal displacement between tower and the wall is  $\Delta x = 2.4 \text{ m} = v_0 t_w$  so that for the minimum launch speed:  $v_{\text{min}} = \Delta x/t_w$ ,

$$v_{\text{min}} = \frac{2.5 \text{ m}}{0.53 \text{ s}} = 4.7 \frac{\text{m}}{\text{s}}.$$

The total time to hit the ground from the launch follows from the height of the tower  $\Delta y_{\text{tot}} = -7.3 \text{ m}$ . The total vertical displacement follows  $\Delta y_{\text{tot}} = -7.3 \text{ m} = -gt_g^2/2$  so that the time to hit the ground follows:  $t_g = \sqrt{-2\Delta y_{\text{tot}}/g}$ ,

$$t_g = \sqrt{-\frac{2 \cdot (-7.3 \text{ m})}{9.8 \text{ m/s}^2}} = 1.22 \text{ s}.$$

Thus the time from the wall to the ground:  $\Delta t = t_g - t_w = 1.22 \text{ s} - 0.53 \text{ s} = 0.69 \text{ s}$ . The balls falls at the shortest distance  $D$  behind the wall:  $D_{\text{min}} = v_{\text{min}} \Delta t$ ,

$$D_{\text{min}} = 4.7 \frac{\text{m}}{\text{s}} \cdot 0.69 \text{ s} = 3.24 \text{ m}.$$



**Nido**

**Luxurious accommodation**

**Central zone 1 & 2 locations**

**Meet hundreds of international students**

**BOOK NOW and get a £100 voucher from voucherexpress**

**Nido Student Living - London**

**Visit [www.NidoStudentLiving.com/Bookboon](http://www.NidoStudentLiving.com/Bookboon) for more info.**

**+44 (0)20 3102 1060**



**Problem 1.65:** We use the principle of conservation of energy. Initially, the block is at rest  $KE_i = 0$ , and we have only gravitational potential energy  $PE = mgh$ ,

$$PE_i = 4.3 \text{ kg} \cdot 9.8 \frac{\text{m}}{\text{s}^2} \cdot 0.24 \text{ m} = 10.1 \text{ J}.$$

At the ground, the gravitational potential energy of the hanging block is zero:  $PE_f = 0$ . The kinetic energy of the entire system has three contributions:  $KE = KE_{\text{trans,block}} + KE_{\text{trans,wheel}} + KE_{\text{rot,wheel}}$ . Since the wheel rolls without slipping, we find the angular speed  $\omega = v/r$ ,

$$KE = \frac{1}{2} 4.3 \text{ kg} \cdot v^2 + \frac{1}{2} 5.4 \text{ kg} \cdot v^2 + \frac{1}{2} 0.014 \text{ kg m}^2 \cdot \left(\frac{v}{0.06 \text{ m}}\right)^2 = \frac{1}{2} 13.6 \text{ kg} \cdot v^2$$

We set  $PE_i = KE_f$  and find  $10.1 \text{ J} = 13.6 \text{ kg} \cdot v^2/2$  so that the linear speed follows

$$v = \sqrt{\frac{2 \cdot 10.1 \text{ J}}{13.6 \text{ kg}}} = 1.2 \frac{\text{m}}{\text{s}}.$$

The final angular speed of the wheel follows  $\omega = v/r$ ,

$$\omega = \frac{1.2 \text{ m/s}}{0.06 \text{ m}} = 20.0 \frac{\text{rad}}{\text{s}}.$$

The change in the *rotational* kinetic energy of the wheel:

$$\Delta KE_{\text{rot,wheel}} = \frac{1}{2} 0.014 \text{ kg m}^2 \left(20.0 \frac{\text{rad}}{\text{s}}\right)^2 = 2.8 \text{ J}.$$

The work - kinetic energy theorem shows that the change in the kinetic energy  $\Delta KE_{\text{rot}}$  is equal to the work done by the torque. The angular displacement of the wheel is given by  $\Delta\theta = h/r = 0.24 \text{ m}/0.06 \text{ m} = 4.0 \text{ rad}$ . Thus the rotational work can be written:  $W_\tau = 2.8 \text{ J} = \tau \cdot 4.0 \text{ rad}$  so that the torque follows  $\tau = W_\tau/\Delta\theta$ ,

$$\tau = \frac{2.8 \text{ J}}{4.0 \text{ rad}} = 0.7 \text{ Nm}.$$

**Problem 1.66:** We calculate the total kinetic energy and the linear momentum *after* the collision:

$$KE_{\text{tot},f} = \frac{0.434 \text{ kg}}{2} \left(-0.4 \frac{\text{m}}{\text{s}}\right)^2 + \frac{0.366 \text{ kg}}{2} \left(1.26 \frac{\text{m}}{\text{s}}\right)^2 = 0.326 \text{ J}$$

$$p_{\text{tot},f} = 0.434 \text{ kg} \cdot \left(-0.40 \frac{\text{m}}{\text{s}}\right) + 0.366 \text{ kg} \cdot 1.26 \frac{\text{m}}{\text{s}} = 0.287 \frac{\text{kg m}}{\text{s}}.$$

The change in the linear momentum of the glider  $m_1$ :

$$\Delta p_1 = 0.434 \text{ kg} \cdot \left(-0.4 \frac{\text{m}}{\text{s}} - 1.2 \frac{\text{m}}{\text{s}}\right) = -0.694 \frac{\text{kg m}}{\text{s}}.$$

Newton's third law implies that the change in the momentum of the two gliders are equal in magnitude and opposite in direction:  $\Delta p_2 = -\Delta p_1 = -0.694 \text{ kg m/s}$ . Since  $\Delta p_2 = m_2(v_{2f} - v_{2i})$ , we find the initial velocity of the second glider  $v_{2i} = v_{2i} = v_{2f} - \Delta p_2/m_2$ ,

$$v_{2i} = 1.26 \frac{\text{m}}{\text{s}} - \frac{0.694 \text{ kg m/s}}{0.366 \text{ kg}} = -0.64 \frac{\text{m}}{\text{s}}.$$

We find the kinetic energy before the collision:

$$\text{KE}_i = \frac{0.434 \text{ kg}}{2} \left(1.20 \frac{\text{m}}{\text{s}}\right)^2 + \frac{0.366 \text{ kg}}{2} \left(-0.64 \frac{\text{m}}{\text{s}}\right)^2 = 0.387 \text{ J}$$

We find the change in the total energy  $\Delta \text{KE} = \text{KE}_f - \text{KE}_i$ ,

$$\Delta \text{KE} = 0.326 \text{ J} - 0.387 \text{ J} = -0.061 \text{ J},$$

Since kinetic energy is "lost,"  $\Delta \text{KE} < 0$ , energy is dissipated during the collision, although it is not *completely* inelastic, since the velocities of the two gliders are not the same either before ( $v_{1i} = v_{2i}$ ) or after the collision ( $v_{1f} = v_{2f}$ ).

**Problem 1.67:** We use a coordinate system for block  $m_1$  such that the  $x$ -axis is along the incline and the  $y$ -axis is perpendicular to the incline. We calculate the  $x$ - and  $y$ -components of the weight  $W_1 = m_1 g = 2.1 \text{ kg} \cdot 9.8 \text{ m/s}^2 = 20.6 \text{ N}$ . We find  $W_{1x} = 20.6 \text{ N} \cdot \sin 35^\circ = 11.8 \text{ N}$  and  $W_{1,y} = 20.6 \text{ N} \cdot \cos 35^\circ = 16.9 \text{ N}$ . We write Newton's second law for the block  $m_1$ :

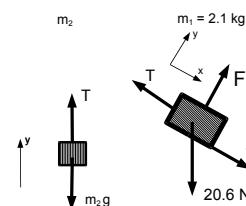

$$\begin{aligned} \sum F_x &= 11.8 \text{ N} + f_s - T = 0, \\ \sum F_y &= F_N - 16.9 \text{ N} = 0. \end{aligned}$$

For the hanging block, we choose the  $y$  along the vertical. Since  $W_2 = m_2 g = 1.6 \text{ kg} \cdot 9.8 \text{ m/s}^2 = 15.7 \text{ N}$  is the weight of the hanging block, we write Newton's second law for the block  $m_2$ :

$$\sum F_y = T - 15.7 \text{ N} = 0.$$

We find  $T = 15.7 \text{ N}$  and  $F_N = 16.9 \text{ N}$ . Since  $11.8 \text{ N} + f_{s,\text{max}} - 15.7 \text{ N} = 0$ , the maximum static friction follows:

$$f_{s,\text{max}} = 15.7 \text{ N} - 11.8 \text{ N} = 3.9 \text{ N}.$$

We obtain the coefficient of static friction:  $\mu_s = f_{s,\text{max}}/F_N$ ,

$$\mu_s = \frac{3.9 \text{ N}}{16.9 \text{ N}} = 0.23.$$

Since  $W'_{1x} = 41.2 \text{ N} \cdot \sin 35^\circ = 23.6 \text{ N}$  and  $W'_{1y} = 41.2 \text{ N} \cdot \cos 35^\circ = 33.8 \text{ N}$ , Newton's second law for  $m_1$  follows:

$$\begin{aligned}\sum F_x &= 23.6 \text{ N} - f_k - T' = 4.2 \text{ kg} \cdot a, \\ \sum F_y &= F'_N - 33.8 \text{ N} = 0.\end{aligned}$$

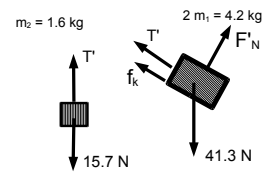

Newton's second law for the block  $m_2$  now reads:

$$\sum F_y = T' - 15.7 \text{ N} = 1.6 \text{ kg} \cdot a.$$

We find  $F'_N = 33.8 \text{ N}$ . We insert the acceleration  $a = 0.31 \text{ m/s}^2$  and find the tension in the string:

$$T' = 15.7 \text{ N} + 1.6 \text{ kg} \cdot 0.31 \frac{\text{m}}{\text{s}^2} = 16.2 \text{ N}.$$

The kinetic friction force follows:

$$f_k = 23.7 \text{ N} - 16.2 \text{ N} - 4.2 \text{ kg} \cdot 0.31 \frac{\text{m}}{\text{s}^2} = 6.2 \text{ N}.$$

We then find the coefficient of kinetic friction:  $\mu_k = f_k/F'_N$ ,

$$\mu_k = \frac{6.2 \text{ N}}{33.8 \text{ N}} = 0.18.$$

**Brain power**

By 2020, wind could provide one-tenth of our planet's electricity needs. Already today, SKF's innovative know-how is crucial to running a large proportion of the world's wind turbines.

Up to 25 % of the generating costs relate to maintenance. These can be reduced dramatically thanks to our systems for on-line condition monitoring and automatic lubrication. We help make it more economical to create cleaner, cheaper energy out of thin air.

By sharing our experience, expertise, and creativity, industries can boost performance beyond expectations. Therefore we need the best employees who can meet this challenge!

The Power of Knowledge Engineering

Plug into The Power of Knowledge Engineering. Visit us at [www.skf.com/knowledge](http://www.skf.com/knowledge)

**SKF**

**Problem 1.68:** The forces are the weights  $m_1g$  and  $m_2g = 2.45\text{ N}$  downward and the tensions  $T_1$  and  $T_2$  of the ropes. Note that  $T_1 \neq T_2$ , in general. We find Newton's second law for the higher block:

$$\begin{aligned}\sum F_x &= T_1 \sin 24^\circ - T_2 \sin 35^\circ = m_1 a_{c,1}, \\ \sum F_y &= T_1 \cos 24^\circ - T_2 \cos 35^\circ - m_1g = 0,\end{aligned}$$

and Newton's second law for the lower block:

$$\begin{aligned}\sum F_x &= T_2 \sin 35^\circ = 0.25\text{ kg} \cdot a_{c,2}, \\ \sum F_y &= T_2 \cos 35^\circ - 2.45\text{ N} = 0.\end{aligned}$$

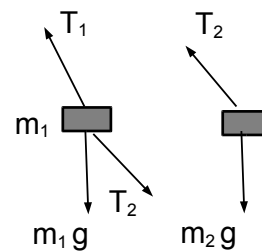

For the block  $m_2$ :  $T_2 \cos 35^\circ = 2.45\text{ N}$  so that

$$T_2 = \frac{2.45\text{ N}}{\cos 35^\circ} = 3.0\text{ N}.$$

Since  $3.0\text{ N} \cdot \sin 35^\circ = 1.72\text{ N}$ , we find the centripetal acceleration of the lower block:

$$a_{c,2} = \frac{1.72\text{ N}}{0.25\text{ kg}} = 6.9 \frac{\text{m}}{\text{s}^2}.$$

We find the radii  $r_1 = 0.68\text{ m} \cdot \sin 24^\circ = 0.35\text{ m}$  and  $r_2 = 0.68\text{ m} \cdot (\sin 24^\circ + \sin 35^\circ) = 0.84\text{ m}$ . Since the centripetal acceleration of the lower block is given by  $a_{c,2} = v_2^2/r_2$ , we find the speed of the lower block:  $v_2 = \sqrt{a_{c,2}r_2}$ ,

$$v_2 = \sqrt{6.9 \frac{\text{m}}{\text{s}^2} \cdot 0.84\text{ m}} = 2.4 \frac{\text{m}}{\text{s}}.$$

Since  $v_2 = 2\pi r_2/T$ , we obtain the period:  $T = 2\pi r_2/v_2$ ,

$$T = \frac{2\pi \cdot 0.84\text{ m}}{2.4\text{ m/s}} = 2.2\text{ s}.$$

Since the period is the same for both blocks, we find the centripetal acceleration of the higher block  $m_1$ :  $a_{c1} = (2\pi \cdot 0.35\text{ m}/2.2\text{ s})^2/0.35\text{ m} = 2.9\text{ m/s}^2$ . We use  $3.0\text{ N} \cdot \cos 35^\circ = 2.45\text{ N}$  and  $3.0\text{ N} \cdot \sin 35^\circ = 1.72\text{ N}$ , and  $\sin 24^\circ = 0.41$  and  $\cos 24^\circ = 0.91$ :

$$\begin{aligned}0.41 \cdot T_1 - 1.72\text{ N} &= m_1 \cdot 2.9 \frac{\text{m}}{\text{s}^2} \\ 0.91 \cdot T_1 - 2.45\text{ N} &= m_1 \cdot 9.8 \frac{\text{m}}{\text{s}^2}.\end{aligned}$$

We divided the equations by 0.41 and 0.91, respectively, and obtain:

$$\begin{aligned}T_1 - 4.2\text{ N} &= m_1 \cdot 7.1 \frac{\text{m}}{\text{s}^2} \\ T_1 - 2.7\text{ N} &= m_1 \cdot 10.8 \frac{\text{m}}{\text{s}^2}\end{aligned}$$

We subtract the two equations from each other:  $1.5\text{ N} = m_1 \cdot 3.7\text{ m/s}^2$ , and find the mass of the higher block:

$$m_1 = \frac{1.5\text{ N}}{3.7\text{ m/s}^2} = 0.40\text{ kg},$$



the tension in the string connecting  $m_1$  to the ceiling then follows

$$T_1 = 4.2 \text{ N} + 0.40 \text{ kg} \cdot 7.1 \frac{\text{m}}{\text{s}^2} = 7.0 \text{ N}.$$

**Problem 1.69:** The initial angle  $\theta_0 = 45^\circ$  gives the maximum range so that  $R = v_0^2/g$  and the initial speed follows  $v_0 = \sqrt{Rg}$ ,

$$v_0 = \sqrt{70 \text{ m} \cdot 9.8 \frac{\text{m}}{\text{s}^2}} \simeq 25 \frac{\text{m}}{\text{s}}.$$

The change in the ball's momentum is  $\Delta p = mv_0 \simeq 1 \text{ N}\cdot\text{s}$ . Since the change in momentum is equal to the impulse  $J = \Delta p = 1 \text{ N}\cdot\text{s}$ . We insert the force acting on the golf ball,  $F = 9 \times 10^3 \text{ N}$ , and find the time of contact,  $\Delta t = J/F$ ,

$$\Delta t = \frac{1 \text{ N}\cdot\text{s}}{9 \times 10^3 \text{ N}} \simeq 0.1 \text{ ms}.$$

This makes sense: the collision is nearly elastic so that the impact only lasts for a very short time. The change in the ball's kinetic energy is:  $\Delta \text{KE} = mv_0^2/2 \simeq 15 \text{ J}$ . Since the change in kinetic energy is equal to the work done by the force  $F$ , we find  $W = \Delta \text{KE} = 25 \text{ J}$ . Since  $W = F \delta$ , we find the distortion of the golf ball follows  $\delta = \Delta \text{KE}/F$ ,

$$\delta = \frac{15 \text{ J}}{9 \times 10^3 \text{ N}} \simeq 0.2 \text{ cm}.$$

We calculate the ratio of the compression of the golf ball to the diameter  $\delta/D = 0.2 \text{ cm}/4.2 \text{ cm} = 0.05$  or about 5%.

**Problem 1.70:** We write  $x$ -coordinate at time  $t_1 = 0.34 \text{ s}$ :  $x_1 = 1.2 \text{ m} = v_{x,0} \cdot 0.34 \text{ s}$  so that  $v_{x,0} = x_1/t_1$ ,

$$v_{x,0} = \frac{1.2 \text{ m}}{0.34 \text{ s}} = 3.53 \frac{\text{m}}{\text{s}}.$$

We write the  $y$ -coordinate at time  $t_1 = 0.34 \text{ s}$ :  $y_1 = 0.45 \text{ m} = v_{y,0} \cdot 0.34 \text{ s} - 9.8 \text{ m/s}^2 \cdot (0.34 \text{ s})^2/2$  so that

$$v_{y,0} = \frac{0.45 \text{ m}}{0.34 \text{ s}} + \frac{1}{2} 9.8 \frac{\text{m}}{\text{s}^2} \cdot 0.34 \text{ s} = 3.0 \frac{\text{m}}{\text{s}}.$$

We find the launch speed  $v_0 = \sqrt{v_{x,0}^2 + v_{y,0}^2}$ ,

$$v_0 = \sqrt{\left(3.53 \frac{\text{m}}{\text{s}}\right)^2 + \left(3.0 \frac{\text{m}}{\text{s}}\right)^2} = 4.63 \frac{\text{m}}{\text{s}}$$

and launch angle  $\tan \theta_0 = v_{y,0}/v_{x,0} = (3.0 \text{ m/s})/(3.53 \text{ m/s}) = 0.84$  so that

$$\theta_0 = \tan^{-1} 0.84 = 40.4^\circ.$$

The  $x$ - and  $y$ -coordinates at the time  $t_2 = 0.53$  s follow,

$$x_2 = 3.53 \frac{\text{m}}{\text{s}} \cdot 0.53 \text{ s} = 1.87 \text{ m},$$
$$y_2 = 3.0 \frac{\text{m}}{\text{s}} \cdot 0.53 \text{ s} - \frac{1}{2} 9.8 \frac{\text{m}}{\text{s}^2} \cdot (0.53 \text{ s})^2 = 0.21 \text{ m}.$$

The time to reach the peak follows from  $v_y = 0 = 3.53 \text{ m/s} - 9.8 \text{ m/s}^2 t_p$  so that the time to reach the peak of the trajectory follows:

$$t_p = \frac{3.53 \text{ m/s}}{9.8 \text{ m/s}^2} = 0.36 \text{ s}.$$

We then find the coordinates of the peak:

$$x_p = 3.53 \frac{\text{m}}{\text{s}} \cdot 0.36 \text{ s} = 1.27 \text{ m},$$
$$y_p = 3.0 \frac{\text{m}}{\text{s}} \cdot 0.36 \text{ s} - \frac{1}{2} 9.8 \frac{\text{m}}{\text{s}^2} \cdot (0.36 \text{ s})^2 = 0.44 \text{ m}.$$



**GET A MASTER'S DEGREE IN UMEÅ!**

- modern campus • world class research • 32 000 students
- top class teachers • ranked nr 1 in Sweden by international students

**Master's programmes:**

- Architecture
- Industrial Design
- Science
- Engineering

Download brochure here!



**UMEÅ UNIVERSITY**  
FACULTY OF SCIENCE & TECHNOLOGY



**Problem 2.1:** We find the heat given off by the (luke-warm) water:

$$Q^\uparrow = 0.117 \text{ kg} \cdot 4186 \frac{\text{J}}{\text{kg} \cdot ^\circ\text{C}} \cdot (51^\circ\text{C} - 35^\circ\text{C}) = 7.8 \times 10^3 \text{ J}.$$

and the absorbed heat:

$$Q^\downarrow = 0.062 \text{ kg} \cdot c_{\text{apple}} \cdot (35^\circ - 0^\circ\text{C}) = 2.2 \text{ kg} \cdot ^\circ\text{C} \cdot c_{\text{apple}}.$$

We assume that no heat is lost and set  $Q^\uparrow = Q^\downarrow$  so that the average specific heat of the apple follows

$$c_{\text{apple}} = \frac{7.8 \times 10^3 \text{ J}}{2.2 \text{ kg} \cdot ^\circ\text{C}} = 3.6 \times 10^3 \frac{\text{J}}{\text{kg} \cdot ^\circ\text{C}}.$$

We use  $m_w$  and  $m_c$  for the mass of water and cellulose in apple, respectively. Then for the for the mass of apple:

$$m_{\text{apple}} = m_w + m_c$$

and the specific heat:

$$m_{\text{apple}}c_{\text{apple}} = m_w c_w + m_c c_c$$

We use the mass ratio of water  $\zeta = m_w/m_{\text{apple}}$  so that  $1 - \zeta = m_c/m_{\text{apple}}$ . We obtain

$$c_{\text{apple}} = c_w \zeta + c_c (1 - \zeta)$$

so that the water content of apple follows  $\zeta = (c_{\text{apple}} - c_c)/(c_w - c_c)$ ,

$$\zeta = \frac{3.6 \times 10^3 \text{ J}/(\text{kg} \cdot ^\circ\text{C}) - 1.4 \times 10^3 \text{ J}/(\text{kg} \cdot ^\circ\text{C})}{4.2 \times 10^3 \text{ J}/(\text{kg} \cdot ^\circ\text{C}) - 1.4 \times 10^3 \text{ J}/(\text{kg} \cdot ^\circ\text{C})} = 0.78,$$

or  $\zeta = m_{\text{water}}/m_{\text{total}} = 78\%$ . That is, 22% of apples is “dietary fiber.” This value agrees with literature values [<http://www2.ca.uky.edu/enri/pubs/enri129.pdf>]. Such a calorimetry experiment would be quite “tricky,” since small inaccuracies can yield different values for the fiber content. For this reason, the water content in fruits and vegetables is determined using buoyancy.

**Problem 2.2:** We calculate the volume  $V = Ah = 1.0 \times 10^{-2} \text{ m}^2 \cdot 7.0 \times 10^{-2} \text{ m} = 7.0 \times 10^{-4} \text{ m}^3$ , and use the ideal gas law:  $nRT_0 = P_0 V_0 = 1.0 \times 10^5 \text{ Pa} \cdot 7.0 \times 10^{-4} \text{ m}^3 = 70 \text{ J}$ . We find the internal energies of the gas inside the two compartments:  $U_i = 2 \cdot (5/2)nRT_0 = 5nRT_0$ ,

$$U_i = 5 \cdot 70 \text{ J} = 350 \text{ J}.$$

Work is done on the gas by the piston. Since the weight is  $mg = 5.0 \times 10^3 \text{ N}$  and the displacement is  $s = 5.0 \times 10^{-2} \text{ m}$ , we find the work done on the gas,  $W = mg \cdot s$ ,

$$W = 5.0 \times 10^3 \text{ N} \cdot 5.0 \times 10^{-2} \text{ m} = 250 \text{ N}.$$

The internal energy of the gas increases due to work done by the piston:  $U_f = U_i + W$ ,

$$U_f = 350 \text{ J} + 250 \text{ J} = 600 \text{ J}.$$

The number of molecules is fixed so that  $U/T = (5/2)nR = \text{const.}$  We thus find  $350 \text{ J}/300 \text{ K} = 600 \text{ J}/T$  and find the temperature:

$$T = \frac{600 \text{ J}}{350 \text{ J}} \cdot 300 \text{ K} = 514 \text{ K}.$$

We use the ideal gas law  $PV/T = \text{const.}$  Since the volume of the compartments are proportional to the height of the piston  $V \sim \cdot h$ , we find for the ratio  $V/V' = h/h'$ . We obtain for the pressure in the upper and lower compartments:

$$P_u = 1.0 \times 10^5 \text{ Pa} \cdot \frac{7 \text{ cm}}{12 \text{ cm}} \cdot \frac{514 \text{ K}}{300 \text{ K}} = 1.0 \times 10^5 \text{ Pa},$$

$$P_l = 1.0 \times 10^5 \text{ Pa} \cdot \frac{7 \text{ cm}}{2 \text{ cm}} \cdot \frac{514 \text{ K}}{300 \text{ K}} = 6.0 \times 10^5 \text{ Pa}.$$

The pressure difference  $\Delta P = P_l - P_u$  follows,

$$\Delta P = 6.0 \times 10^5 \text{ Pa} - 1.0 \times 10^5 \text{ Pa} = 5.0 \times 10^5 \text{ Pa}.$$

We find the (upwards) force on the piston:  $F_{\text{up}} = \Delta P \cdot A$ ,

$$F_{\text{up}} = 5.0 \times 10^5 \text{ Pa} \cdot 1.0 \times 10^{-2} \text{ m}^2 = 5.0 \times 10^3 \text{ N}.$$

Since the piston is in *mechanical* equilibrium, the net force follows  $F_{\text{net}} = F_{\text{up}} - mg = 0$

$$F_{\text{up}} = 500 \text{ kg} \cdot 9.8 \frac{\text{m}}{\text{s}^2} = 5.0 \times 10^3 \text{ N},$$

as it should!

*Note:* With some (*a bit tricky!*) algebra, one finds that the lower compartment is *not* completely compressed even when an arbitrarily heavy block is placed on the hanger. We use  $h$  for the initial height of the lower compartment [e.g.,  $h = 7 \text{ cm}$ ], then  $h_{\text{min}}/h = (1 - \sqrt{5/7}) \simeq 0.15$ .

**Problem 2.3:** We find the volume  $V = \pi (d/2)^2 h$ ,

$$V = \pi (1.22 \times 10^{-2} \text{ m})^2 \cdot 1.75 \times 10^{-3} \text{ m} = 8.2 \times 10^{-7} \text{ m}^3.$$

Thus, the buoyant force is given by  $F_b = \rho_w V g$ ,

$$F_b = 1,000 \frac{\text{kg}}{\text{m}^3} \cdot 8.2 \times 10^{-7} \text{ m}^3 \cdot 9.8 \frac{\text{m}}{\text{s}^2} = 8.0 \times 10^{-3} \text{ N}.$$

We use  $h = at^2/2$  so that  $a = 2h/t^2$ ,

$$a = \frac{2 \cdot 1.5 \text{ m}}{(0.60 \text{ s})^2} = 8.3 \frac{\text{m}}{\text{s}^2}.$$

The mass of the quarter follows:  $m = \rho_q V$  so that  $F_{\text{net}} = \rho_q V a = \rho_q V g - \rho_w V g$ , or  $\rho_q a = \rho_q g - \rho_w g$ . We obtain  $\rho_q (g - a) = \rho_w g$ . The average density of the quarter follows:  $\rho_q = \rho_w \cdot g / (g - a)$ ,

$$\rho_q = 1,000 \frac{\text{kg}}{\text{m}^3} \cdot \frac{9.8 \text{ m/s}^2}{9.8 \text{ m/s}^2 - 8.3 \text{ m/s}^2} = 6,530 \frac{\text{kg}}{\text{m}^3}.$$

**Problem 2.4:** We find the pressure: on the chest  $P = F/A$ ,

$$P = \frac{400 \text{ N}}{0.09 \text{ m}^2} = 4.4 \text{ kPa}.$$

The above pressure is equal to the hydrostatic pressure:  $P = \rho gh$ . We solve for the height:  $h = P/\rho g$ ,

$$h = \frac{4.4 \text{ kPa}}{1,000 \text{ kg/m}^3 \cdot 9.8 \text{ m/s}^2} = 0.45 \text{ m};$$

that is, *snorkeling is limited to just below the surface!*

**Problem 2.5:** The mass flow is given by

$$\frac{\Delta V}{\Delta t} = \frac{16 \times 10^{-3} \text{ m}^3}{4.2 \text{ s}} = 3.8 \times 10^{-3} \frac{\text{m}^3}{\text{s}}.$$

The volume flow is determined by the cross section and the flow speed:  $\Delta V/\Delta t = Av$ . The cross section is given by  $A = \pi(d/2)^2 = 3.1 \times 10^{-4} \text{ m}^2$ . Thus,  $v = (\Delta V/\Delta t)/A$ ,

$$v = \frac{3.8 \times 10^{-3} \text{ m}^3/\text{s}}{3.1 \times 10^{-4} \text{ m}^2} = 12.3 \frac{\text{m}}{\text{s}}.$$

We find the ratio of the two cross sections:  $A/A' = (d/d')^2 = (2.0 \text{ cm}/1.6 \text{ cm})^2 = 1.56$ . Now use the equation of continuity:  $Av = A'v'$  and solve for the speed in the constricted part  $v' = (A/A')v$ :

$$v' = 1.56 \cdot 12.3 \frac{\text{m}}{\text{s}} = 19.2 \frac{\text{m}}{\text{s}}.$$

We use Bernoulli's equation for the horizontal pipe:  $P + \rho v^2/2 = P' + \rho(v')^2/2$ , so that the pressure in the constricted part follows  $P' = P + (\rho/2)[v^2 - (v')^2]$

$$P' = 142 \text{ kPa} + \frac{1,000 \text{ kg/m}^3}{2} \left[ \left(12.3 \frac{\text{m}}{\text{s}}\right)^2 - \left(19.2 \frac{\text{m}}{\text{s}}\right)^2 \right] = 33 \text{ kPa}.$$

**Problem 2.6:** We find the hydrostatic pressure of the water column inside the pipette:  $P_{\text{hydro}} = \rho gh$ ,

$$P_{\text{hydro}} = 1000 \frac{\text{kg}}{\text{m}^3} \cdot 9.8 \frac{\text{m}}{\text{s}^2} \cdot 0.037 \text{ m} = 362 \text{ Pa}.$$

We obtain  $P + P_{\text{hydro}} = P_0$  so that  $\Delta P = P - P_0$ ,

$$\Delta P = -362 \text{ Pa}.$$

That is, there is less pressure inside the pipette. Bernoulli equation yields:  $P + \rho_{\text{air}}v^2/2 = P_0$  so that  $-\Delta P = P_0 - P = \rho_{\text{air}}2v^2/2$ . We find the air speed above the pipette:  $v = \sqrt{-2\Delta P/\rho}$ ,

$$v = \sqrt{\frac{2 \cdot (-362 \text{ Pa})}{1.29 \text{ kg/m}^3}} = 23.7 \frac{\text{m}}{\text{s}}.$$

**Problem 2.7:** The cross-sectional area of the block is  $A = 0.33 \text{ m}^2$ . When the block swims on water, the submerged volume is  $V_s = 0.33 \text{ m}^2 \cdot 0.13 \text{ m} = 4.26 \times 10^{-2} \text{ m}^3$ . The buoyant force follows

$$F_B = 4.26 \times 10^{-2} \text{ m}^3 \cdot 1.0 \times 10^3 \frac{\text{kg}}{\text{m}^3} \cdot 9.8 \frac{\text{m}}{\text{s}^2} = 417 \text{ N}.$$

The total volume  $V_{\text{tot}} = 0.33 \text{ m}^2 \cdot 0.17 \text{ m} = 5.57 \times 10^{-2} \text{ m}^3$ . Since the buoyant force is equal to the weight of the block, we find  $F_B = m_w g = \rho_{\text{wood}} V_{\text{tot}} g$ . The density of wood follows,  $\rho_{\text{wood}} = F_B / V_{\text{tot}} g$ ,

$$\rho_{\text{wood}} = \frac{417 \text{ N}}{5.57 \times 10^{-2} \text{ m}^3 \cdot 9.8 \text{ m/s}^2} = 764 \frac{\text{kg}}{\text{m}^3}.$$

We now dunk the block. The submerged volume is  $V'_s = 0.33 \text{ m}^2 \cdot 0.14 \text{ m} = 4.59 \times 10^{-2} \text{ m}^3$  so that the buoyant force now is  $F'_B = m_{\text{block}} g$ ,

$$F'_B = 1000 \frac{\text{kg}}{\text{m}^3} \cdot 4.59 \times 10^{-2} \text{ m}^3 \cdot 9.8 \frac{\text{m}}{\text{s}^2} = 450 \text{ N}.$$

Thus, the necessary external force is  $F_{\text{ext}} = F'_B - W_{\text{block}}$ ,

$$F_{\text{ext}} = 450 \text{ N} - 417 \text{ N} = 33 \text{ N}.$$

The external force is proportional to the “dunk” distance, i.e.,  $x = 1.0 \text{ cm}$ . We thus find the “spring constant:”  $F_{\text{ext}} = kx$  so that  $k = F_{\text{ext}}/x$ ,

$$k = \frac{33 \text{ N}}{0.01 \text{ m}} = 3.3 \times 10^3 \frac{\text{N}}{\text{m}}.$$

This ‘spring’ force corresponds to an elastic energy  $\text{PE} = kx^2/2$  so that the work necessary to dunk the wooden block can be written  $W = \Delta \text{PE}$ ,

$$W = \frac{1}{2} 3.3 \times 10^3 \frac{\text{N}}{\text{m}} \cdot (0.01 \text{ m})^2 = 0.17 \text{ J}.$$



*Scholarships*

**Ln.se**

## Open your mind to new opportunities

With 31,000 students, Linnaeus University is one of the larger universities in Sweden. We are a modern university, known for our strong international profile. Every year more than 1,600 international students from all over the world choose to enjoy the friendly atmosphere and active student life at Linnaeus University. Welcome to join us!

**Linnaeus University**  
Sweden

**Bachelor programmes in**  
Business & Economics | Computer Science/IT | Design | Mathematics

**Master programmes in**  
Business & Economics | Behavioural Sciences | Computer Science/IT | Cultural Studies & Social Sciences | Design | Mathematics | Natural Sciences | Technology & Engineering

**Summer Academy courses**



**Problem 2.8:** The absolute temperature is  $T = (312 + 273) \text{ K} = 585 \text{ K}$ . We find the number of moles from the ideal gas law  $n = PV/RT$ ,

$$n = \frac{15.8 \times 10^5 \text{ Pa} \cdot 2.0 \times 10^{-3} \text{ m}^3}{8.3 \text{ J}/(\text{mol} \cdot \text{K}) \cdot 585 \text{ K}} = 0.65 \text{ mol}.$$

We obtain the mass of steam from the molar mass  $m = nM$ ,

$$m_{\text{steam}} = 0.65 \text{ mol} \cdot 18 \frac{\text{g}}{\text{mol}} = 11.7 \text{ g}$$

We find the heat given off by the steam as it condenses:  $Q^\uparrow = m_{\text{steam}}c_{\text{steam}}(312^\circ\text{C} - 100^\circ\text{C}) + m_{\text{steam}}L_{\text{steam}} + m_{\text{steam}}c_{\text{water}}(100^\circ\text{C} - T_f)$  so that

$$Q^\uparrow = 35.8 \text{ kJ} - 49.0 \frac{\text{J}}{^\circ\text{C}} \cdot T_f,$$

and the heat absorbed by the water:  $Q^\downarrow = m_{\text{water}}c_{\text{water}}(T_f - 8^\circ\text{C})$ ,

$$Q^\downarrow = 627.9 \frac{\text{J}}{^\circ\text{C}} \cdot T_f - 5.0 \text{ kJ}.$$

We set  $Q^\uparrow = Q^\downarrow$  and obtain

$$35.8 \text{ kJ} - 49.0 \frac{\text{J}}{^\circ\text{C}} \cdot T_f = 627.9 \frac{\text{J}}{^\circ\text{C}} \cdot T_f - 5.0 \text{ kJ}$$

We find the final temperature of the water

$$T_f = \frac{35.8 \text{ kJ} + 5.0 \text{ kJ}}{627.9 \text{ J}/^\circ\text{C} + 49.0 \text{ J}/^\circ\text{C}} = 60.3^\circ.$$

**Problem 2.9:** Atmospheric pressure is given by  $P_{\text{atm}} = 1.01 \times 10^5 \text{ Pa}$ . We use the ideal gas law to find the number of moles from the volume  $V$  and temperature  $T$ :  $n = P_{\text{atm}}V/RT$ ,

$$n = \frac{1.01 \times 10^5 \text{ Pa} \cdot 6.7 \times 10^{-3} \text{ m}^3}{8.3 \text{ J}/(\text{mol} \cdot \text{K}) \cdot 298 \text{ K}} = 0.27 \text{ mol}.$$

We find the mass of the enclosed oxygen

$$m = 0.27 \text{ mol} \cdot 32 \frac{\text{g}}{\text{mol}} = 8.8 \text{ g}.$$

The pressure at the depth  $h = 5.8 \text{ m}$  is given by:  $P_{\text{water}} = P_{\text{atm}} + \rho_{\text{water}}gh$ ,

$$P_{\text{water}} = 1.01 \times 10^5 \text{ Pa} + 1000 \frac{\text{kg}}{\text{m}^3} \cdot 9.8 \frac{\text{m}}{\text{s}^2} \cdot 5.8 \text{ m} = 1.58 \times 10^5 \text{ Pa}.$$

Because the temperature  $T$  and volume  $V$  are constant, we find the ratio  $V/RT = n/P_{\text{air}} = n_{\text{water}}/P_{\text{water}}$ . The number of moles when the balloon is submerged follows  $n_{\text{water}} = (P_{\text{water}}/P_{\text{atm}})n$ :

$$n_{\text{water}} = \frac{1.58 \times 10^5 \text{ Pa}}{1.01 \times 10^5 \text{ Pa}} \cdot 0.27 \text{ mol} = 0.42 \text{ mol}.$$

We obtain for the oxygen mass necessary to inflate the balloon when it is submerged  $m' = n_{\text{water}}M$ ,

$$m' = 0.42 \text{ mol} \cdot 32 \frac{\text{g}}{\text{mol}} = 13.5 \text{ g}.$$

Thus, we find the mass of the added oxygen  $\Delta m = m' - m$ ,

$$\Delta m = 13.5 \text{ g} - 8.8 \text{ g} = 4.7 \text{ g}.$$

Note that  $\Delta m/m = (P_{\text{water}} - P_{\text{atm}})/P_{\text{atm}}$ .

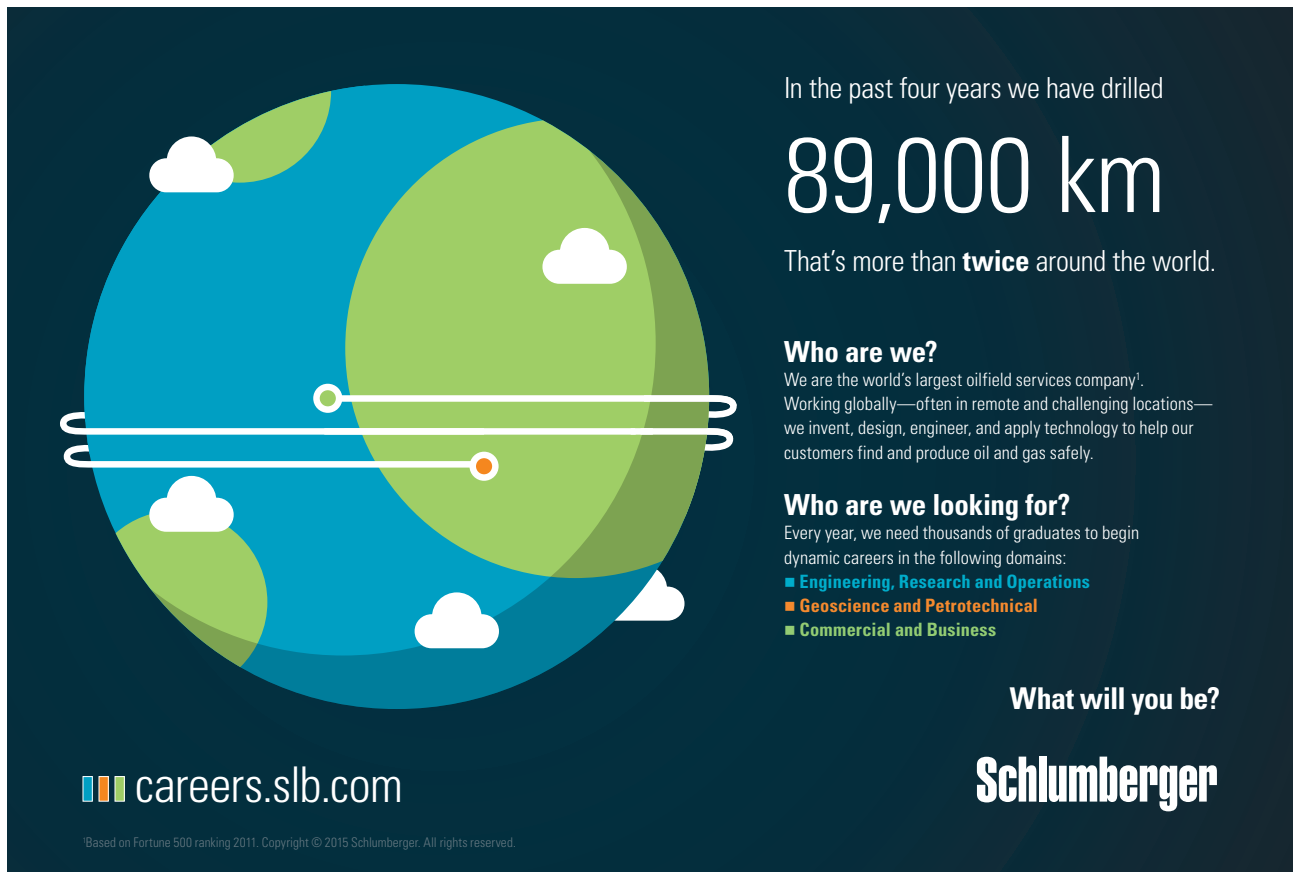

In the past four years we have drilled

# 89,000 km

That's more than **twice** around the world.

**Who are we?**  
We are the world's largest oilfield services company<sup>1</sup>.  
Working globally—often in remote and challenging locations—we invent, design, engineer, and apply technology to help our customers find and produce oil and gas safely.

**Who are we looking for?**  
Every year, we need thousands of graduates to begin dynamic careers in the following domains:

- Engineering, Research and Operations
- Geoscience and Petrotechnical
- Commercial and Business

**What will you be?**

**Schlumberger**

[careers.slb.com](http://careers.slb.com)

<sup>1</sup>Based on Fortune 500 ranking 2011. Copyright © 2015 Schlumberger. All rights reserved.





**Problem 2.10:** We find the temperature change  $\Delta T = 1^\circ\text{F} = \frac{5}{9}^\circ\text{C}$ . Since  $W = mg = 1 \text{ lb} = 4.4 \text{ N}$  so that  $m = 0.453 \text{ kg}$ . The heat follows  $\Delta Q = mc\Delta T$ ,

$$\Delta Q = 0.453 \text{ kg} \cdot 4186 \frac{\text{J}}{\text{kg}^\circ\text{C}} \cdot \left(\frac{5}{9}\right)^\circ\text{C} = 1054 \text{ J}.$$

Thus  $1 \text{ Btu} = 1054 \text{ J}$ . The volume of the living room is  $V = 150 \text{ m}^3$ . We use the ideal gas law to calculate the number of moles of air in the living room,  $n = PV/RT$ ,

$$n = \frac{1.01 \times 10^5 \text{ Pa} \cdot 150 \text{ m}^3}{8.3 \text{ J}/(\text{kg K}) \cdot 285 \text{ K}} = 6,405 \text{ mol}.$$

The mass follows from the molar mass  $m_{\text{LR}} = nM$ ,

$$m_{\text{LR}} = 29 \times 10^{-3} \frac{\text{kg}}{\text{mol}} \cdot 6,405 \text{ mol} = 185.7 \text{ kg}$$

The temperature difference in the living room:  $\Delta T = 7^\circ\text{C}$ . Thus, the heat to raise the temperature inside the living room,  $\Delta Q_{\text{LR}} = m_{\text{LR}}c\Delta T$ ,

$$\Delta Q_{\text{LR}} = 180 \text{ kg} \cdot 780 \frac{\text{J}}{\text{kg}^\circ\text{C}} \cdot 7^\circ\text{C} = 9.8 \times 10^5 \text{ J} = 0.98 \text{ MJ},$$

or about 932 Btu.

**Problem 2.11:** Since heat is a form of energy (or work), the heat follows from the power and the time:  $Q = Pt$ ,

$$Q = 1500 \text{ W} \cdot 60 \text{ s} = 9.0 \times 10^4 \text{ J}.$$

Since  $\Delta T = 25^\circ\text{C}$ , we find the mass of air that is replaced during one minute:  $\Delta m = Q/c\Delta t$ ,

$$\Delta m = \frac{9.0 \times 10^4 \text{ J}}{780 \text{ J}/(\text{kg}^\circ\text{C}) \cdot 25^\circ\text{C}} = 4.6 \text{ kg}.$$

We obtain the fraction of air:  $\chi = \Delta m/m_{\text{total}}$ ,

$$\chi = \frac{4.6 \text{ kg}}{400 \text{ kg}} \simeq 1\%.$$

This seems quite reasonable. We use a heat pump between the inside of the living room,  $T_{\text{hot}} = 298 \text{ K}$  and the cold ambient air  $T_{\text{cold}} = 273 \text{ K}$ . The heat delivered to hot reservoir thus follows  $\Delta Q_{\text{hot}} = 90 \text{ kJ}$ . We assume an ideal Carnot heat pump so that  $\Delta Q_{\text{hot}}/T_{\text{hot}} = \Delta Q_{\text{cold}}/T_{\text{cold}}$ . We find the heat removed from the ambient air:  $Q_{\text{cold}} = (T_{\text{cold}}/T_{\text{hot}})Q_{\text{hot}}$ ,

$$\Delta Q_{\text{cold}} = \frac{273 \text{ K}}{298 \text{ K}} \cdot 90 \text{ kJ} = 82.5 \text{ kJ}.$$

Because the heat removed from the ambient air  $\Delta Q_{\text{cold}}$  is *free*, the necessary input of work follows  $W = \Delta Q_{\text{hot}} - \Delta Q_{\text{cold}}$ ,

$$W = 90 \text{ kJ} - 82.5 \text{ kJ} = 7.5 \text{ kJ}.$$

The power necessary to run the heat pump follows:  $P' = W/t$ ,

$$P' = \frac{7500 \text{ J}}{60 \text{ s}} = 125 \text{ W}.$$

Since  $P/P' = 1500 \text{ W}/125 \text{ W} = 12$ , the heat pump is 12 times more efficient than the space heater!

**Problem 2.12:** Since the buoy is completely under water, we find the buoyant force  $F_b = \rho g V$ ,

$$F_b = 1.0 \times 10^3 \frac{\text{kg}}{\text{m}^3} \cdot 9.8 \frac{\text{m}}{\text{s}^2} \cdot 5.4 \times 10^{-3} \text{ m}^3 = 52.9 \text{ N},$$

the weight of the buoy is  $W = mg$ ,

$$W = 1.75 \text{ kg} \cdot 9.8 \frac{\text{m}}{\text{s}^2} = 17.2 \text{ N}.$$

The force on the submerged buoy are the buoyant force  $F_b$ , the weight of the buoy  $W$ , and the tension in the string:  $F_b - W - T = 0$ . The tension in the string follows  $T = F_b - W$ ,

$$T = 52.9 \text{ N} - 17.2 \text{ N} = 35.7 \text{ N}.$$

When the buoy swims, its weight must be equal to the buoyant force, i.e.,  $F'_b = W$ . We thus find the submerged volume  $V' = W/\rho g$ ,

$$V' = \frac{17.2 \text{ N}}{1.0 \times 10^3 \text{ kg/m}^3 \cdot 9.8 \text{ m/s}^2} = 1.8 \times 10^{-3} \text{ m}^3 = 1.8 \text{ liters}$$

The volume fraction of the buoy under water is  $\chi = V'/V$ ,

$$\chi = \frac{1.81}{5.41} = \frac{1}{3} \quad [\text{or } 33\%].$$

**Problem 2.13:** We use the ideal gas law  $PV = nRT$  to calculate the number of air molecules inside the balloon at the temperature  $T_0 = 20^\circ\text{C} = 293 \text{ K}$ :  $n_0 = PV/RT_0$ ,

$$n_0 = \frac{1.01 \times 10^5 \text{ Pa} \cdot 623 \text{ m}^3}{8.3 \text{ J/(K mol)} \cdot 293 \text{ K}} = 2.59 \times 10^4 \text{ mol}.$$

The number of air molecules at the temperature  $T_1 = 62^\circ\text{C} = 335 \text{ K}$ ,  $n_1 = PV/RT_1$

$$n_1 = \frac{1.01 \times 10^5 \text{ Pa} \cdot 623 \text{ m}^3}{8.3 \text{ J/(K mol)} \cdot 335 \text{ K}} = 2.26 \times 10^4 \text{ mol},$$

Thus the number of moles of expelled air:  $\Delta n = n_0 - n_1$ ,

$$\Delta n = 2.59 \times 10^4 \text{ mol} - 2.26 \times 10^4 \text{ mol} = 3.3 \times 10^3 \text{ mol}.$$

The buoyant force on the balloon is given by  $F_B = n_0 Mg$

$$F_B = 2.59 \times 10^4 \text{ mol} \cdot 28.9 \times 10^{-3} \frac{\text{kg}}{\text{mol}} \cdot 9.8 \frac{\text{m}}{\text{s}^2} = 7335 \text{ N}.$$

The total mass of the balloon [i.e., hot air and load]:  $m_{\text{balloon}} = n_1 M + m,$

$$m_{\text{balloon}} = 2.26 \times 10^4 \text{ mol} \cdot 28.9 \times 10^{-3} \frac{\text{kg}}{\text{mol}} + 74 \text{ kg} = 727 \text{ kg}.$$

We find Newton's second law for the balloon:  $F_B - m_{\text{balloon}}g = m_{\text{balloon}}a,$  We thus find the acceleration:  $a = F_b/m_{\text{balloon}} - g,$

$$a = \frac{7335 \text{ N}}{727 \text{ kg}} - 9.8 \frac{\text{m}}{\text{s}^2} = 0.29 \frac{\text{m}}{\text{s}^2}.$$

Since  $H = at^2/2,$  the time to reach tower follows  $t = \sqrt{2H/a},$

$$t = \sqrt{\frac{2 \cdot 216 \text{ m}}{0.29 \text{ m/s}^2}} = 39 \text{ s}.$$

## Trust and responsibility

NNE and Pharmaplan have joined forces to create NNE Pharmaplan, the world's leading engineering and consultancy company focused entirely on the pharma and biotech industries.

Inés Aréizaga Esteva (Spain), 25 years old  
Education: Chemical Engineer

– You have to be proactive and open-minded as a newcomer and make it clear to your colleagues what you are able to cope. The pharmaceutical field is new to me. But busy as they are, most of my colleagues find the time to teach me, and they also trust me. Even though it was a bit hard at first, I can feel over time that I am beginning to be taken seriously and that my contribution is appreciated.



NNE Pharmaplan is the world's leading engineering and consultancy company focused entirely on the pharma and biotech industries. We employ more than 1500 people worldwide and offer global reach and local knowledge along with our all-encompassing list of services.  
[nnepharmaplan.com](http://nnepharmaplan.com)

nne pharmaplan®



**Problem 2.14:** We use the ideal gas law  $PV = nRT$ , and find the number of moles on the left and right side:  $n_i = P_i V_i / RT_i$ ,

$$n_1 = \frac{1.01 \times 10^5 \text{ Pa} \cdot 4.3 \times 10^{-3} \text{ m}^3}{8.3 \text{ J}/(\text{K mol}) \cdot 313 \text{ K}} = 0.167 \text{ mol},$$

$$n_2 = \frac{1.01 \times 10^5 \text{ Pa} \cdot 5.7 \times 10^{-3} \text{ m}^3}{8.3 \text{ J}/(\text{K mol}) \cdot 365 \text{ K}} = 0.187 \text{ mol}.$$

The final temperature is determined by the conservation of energy:  $U_1 + U_2 = U_{\text{final}}$  so that  $(5/2)Rn_1T_1 + (5/2)n_2RT_2 = (5/2)R(n_1 + n_2)T_{\text{final}}$ . We solve for the final temperature:  $T_{\text{final}} = (n_1T_1 + n_2T_2)/(n_1 + n_2)$ ,

$$T_{\text{final}} = \frac{0.167 \text{ mol} \cdot 313 \text{ K} + 0.187 \text{ mol} \cdot 365 \text{ K}}{0.167 \text{ mol} + 0.187 \text{ mol}} = 340 \text{ K} = 67^\circ \text{ C}.$$

We find the volume on the left and right side when the wall has moved:  $V'_i = n_i RT_{\text{final}}/P$ ,

$$V'_1 = \frac{0.167 \text{ mol} \cdot 8.3 \text{ J}/(\text{mol K}) \cdot 340 \text{ K}}{1.01 \times 10^5 \text{ Pa}} = 4.7 \text{ liter},$$

$$V'_2 = \frac{0.187 \text{ mol} \cdot 8.3 \text{ J}/(\text{mol K}) \cdot 340 \text{ K}}{1.01 \times 10^5 \text{ Pa}} = 5.3 \text{ liter}.$$

Note that  $V'_1 + V'_2 = 10.0$  liter, as it should. We obtain the change in the volume  $\Delta V_1 = -\Delta V_2 = 0.4$  liter  $= 4.0 \times 10^{-4} \text{ m}^3$ . We find the distance moved by the wall:  $d = |\Delta V|/A$ :

$$d = \frac{3.0 \times 10^{-4} \text{ m}^3}{1.2 \times 10^{-2} \text{ m}^2} = 3.3 \text{ cm}.$$

**Problem 2.15:** The mass of the melting ice is given by:  $\Delta m = \rho_{\text{ice}} \Delta V = \rho_{\text{ice}} A \Delta x$ ,

$$\Delta m = 917 \frac{\text{kg}}{\text{m}^3} \cdot 0.03 \text{ m}^2 \cdot 0.01 \text{ m} = 0.275 \text{ kg}.$$

We find the heat necessary to melt this ice:  $Q_{\text{melt}} = \Delta m \cdot L_{\text{fusion}}$ ,

$$Q_{\text{melt}} = 0.275 \text{ kg} \cdot 33.5 \times 10^4 \frac{\text{kg}}{\text{m}^3} = 9.2 \times 10^4 \text{ J}.$$

“Melting under its own weight” means that the heat for melting comes from the work done by the weight of the ice block  $Q_{\text{melt}} = F_{\text{gravity}} \Delta x$  so that  $F_{\text{gravity}} = Q_{\text{melt}}/\Delta x$ ,

$$F_{\text{gravity}} = \frac{9.2 \times 10^4 \text{ J}}{1.0 \times 10^{-2} \text{ m}} = 9.2 \times 10^6 \text{ N}.$$

Since  $F_{\text{gravity}} = mg = \rho_{\text{ice}} Ah_{\text{max}}g$ , we find the minimum height:  $h_{\text{max}} = F_{\text{gravity}}/\rho_{\text{ice}}Ag$ ,

$$h_{\text{max}} = \frac{9.2 \times 10^6 \text{ N}}{917 \text{ kg}/\text{m}^3 \cdot 0.03 \text{ m}^2 \cdot 9.8 \text{ m}/\text{s}^2} = 34.1 \times 10^3 \text{ m} = 21.2 \text{ mi}.$$

*Note:* Our estimate is off by a factor of about ten; the thickest glacier in Antarctica is 4,500 m [S. Simon, *Icebergs and glaciers* (Mulberry, New York, 1987)]. “Melting under its own weight” can be used to explain the height of mountains; we find  $h_{\max} = L/g$ . The gravitational acceleration on the Moon is smaller than on the Earth  $g_{\text{Moon}} \simeq g_{\text{Earth}}/6$ . This explains why the highest mountain on the Moon [Mt. Huygens] is higher than the highest mountain on Earth [Mt Everest].

**Problem 2.16:** We find the heat given off by the water:

$$Q^\uparrow = 1.7 \text{ kg} \cdot 4186 \frac{\text{J}}{\text{kg } ^\circ\text{C}} \cdot (80^\circ\text{C} - 35^\circ\text{C}) = 3.20 \times 10^5 \text{ J},$$

and the absorbed heat:

$$Q^\downarrow = m_{\text{air}} \cdot 1000 \frac{\text{J}}{\text{kg } ^\circ\text{C}} \cdot (35^\circ\text{C} - 20^\circ\text{C}) = m_{\text{air}} \cdot 15.0 \times 10^3 \frac{\text{J}}{\text{kg}}.$$

Since  $Q^\uparrow = Q^\downarrow$ , we find the mass of ambient air:

$$m_{\text{air}} = \frac{3.20 \times 10^5 \text{ J}}{1.5 \times 10^4 \text{ J/kg}} = 21.3 \text{ kg}.$$

We find the number of moles:  $n = m_{\text{air}}/M_{\text{air}}$ ,

$$n = \frac{21.3 \times 10^3 \text{ g}}{29.0 \text{ g}} = 734 \text{ mol}.$$

This e-book  
is made with  
**SetaPDF**



**SETASIGN**



PDF components for PHP developers

[www.setasign.com](http://www.setasign.com)



We then use the ideal gas law to find the volume of air:  $V = n_{\text{air}}RT/P$ ,

$$V = \frac{734 \text{ mol} \cdot 8.3 \text{ J}/(\text{K mol}) \cdot 293 \text{ K}}{3.8 \cdot 1.013 \times 10^5 \text{ Pa}} = 4.6 \text{ m}^3$$

**Problem 2.17:** When the block floats, the waterline is at the position  $y_0$  from the bottom of the boat. The weight of the boat is balanced by the buoyant force:  $\rho_{\text{ave}}Ahg = \rho_w Ay_0g$ , where  $\rho_{\text{ave}}$  is the unknown density of the block and  $\rho_w = 1000 \text{ kg/m}^3$  is the density of water. We find  $\rho_{\text{ave}}h = \rho_w x_0$ . When the block is lowered so that water line is  $y = y_0 - \delta y$ : the net upward force is  $F_{\text{net}} = \rho_w A(y_0 - \delta y)g - \rho_{\text{ave}}Ahg$ ,

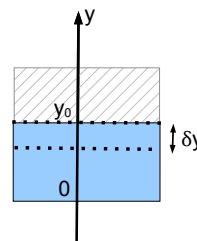

$$F_{\text{net}} = -\rho_w Ag \delta y.$$

We find the “spring constant”  $k = \rho_w Ag = 1000 \text{ kg/m}^3 \cdot 0.32 \text{ m}^2 \cdot 9.8 \text{ m/s}^2 = 3136 \text{ N/m}$ . The net force is thus a linear restoring force, which yields harmonic motion. The angular velocity follows  $\omega = 2\pi/T$ , or

$$\omega = \frac{2\pi \text{ rad}}{5.8 \text{ s}} = 1.08 \frac{\text{rad}}{\text{s}}.$$

The amplitude of the motion is  $\delta y_{\text{max}} = 1.3 \text{ cm}$  so that the maximum speed follows

$$v_{\text{max}} = \omega \delta y_{\text{max}} = 1.08 \frac{\text{rad}}{\text{s}} \cdot 0.013 \text{ m} = 1.4 \times 10^{-2} \frac{\text{m}}{\text{s}}.$$

Since the mass of the boat is  $m = \rho_{\text{ave}}Ah = \rho_{\text{ave}} \cdot 0.39 \text{ m}^3$ , we find the acceleration of the boat  $a = -\rho_w Ag \delta y / \rho_{\text{ave}} Ah$  or,

$$a = -\frac{\rho_{\text{ave}}g}{\rho_w h} \delta y.$$

In general, the relationship between acceleration and displacement determines the angular frequency  $a = -\omega^2 \delta y$ . We thus find  $\omega = \sqrt{\rho_{\text{ave}}g / \rho_w h}$ , so that  $\rho_{\text{ave}} = \omega^2(\rho_w h / g)$ ,

$$\rho_{\text{ave}} = \frac{1000 \text{ kg/m}^3 \cdot 1.22 \text{ m}}{9.8 \text{ m/s}^2} \left(1.08 \frac{\text{rad}}{\text{s}}\right)^2 = 146 \frac{\text{kg}}{\text{m}^3}.$$

**Problem 2.18:** The weight of the plane is  $W = mg = 14.7 \text{ N}$  so that the pressure difference between the top and bottom of the wing follows  $\Delta P = W/A$ ,

$$\Delta P = \frac{14.7 \text{ N}}{0.2 \text{ m}^2} = 73.5 \text{ Pa}.$$

We write  $v_u = v_0$  for the speed of air flow over the upper surface and  $v_l = v_0/2$  for the speed of air flow over the lower surface. We use the Bernoulli equation to express the pressure difference:  $\Delta P = \rho(v_u^2 - v_l^2)/2$ ,

$$\Delta P = \frac{1}{2}\rho \left(v_0^2 - \frac{1}{4}v_0^2\right) = \frac{3}{8}\rho v_0^2.$$

We solve for the speed  $v_0^2 = 8\Delta P/3\rho$ , so that

$$v_0 = \sqrt{\frac{8 \cdot 73.5 \text{ Pa}}{3 \cdot 1.29 \text{ kg/m}^3}} = 12.3 \frac{\text{m}}{\text{s}}.$$

*Note:* This view of air lift is too simplistic, and airflow across wings is much more complex; vortices, in particular, play an important role.

**Problem 2.19:** Since the weight of the car is supported by the gauge pressure:  $W = \Delta P \cdot A$ . The cross-sectional area of the tire treads in contact with the ground  $A = W/\Delta P$ , or

$$A = \frac{8889 \text{ N}}{2.21 \times 10^5 \text{ Pa}} = 4.0 \times 10^{-2} \text{ m}^2 = 400 \text{ cm}^2.$$

Since the car has four tires, the contact area of a single tire tread is  $A' = 100 \text{ cm}$ . A typical tire has a width  $w = 10 \text{ cm}$ . We obtain the arc length of a tire tread in contact with the surface  $s = A'/w$ , or

$$s = \frac{100 \text{ cm}}{10 \text{ cm}} = 10 \text{ cm}.$$

The radius of a typical tire is  $R = 25 \text{ cm}$ . The fraction of the tire tread that is flattened follows  $s/2\pi R$ , or

$$\text{flattened fraction} = \frac{10 \text{ cm}}{2\pi \cdot 25 \text{ cm}} \simeq 0.07 \quad (= 7\%).$$

**Problem 2.20:** The total number of gas molecules is  $N = 123$ . We find the probabilities  $p_i = N_i/N$  and the corresponding speeds  $v_i$

$v$ [m/s]	0 - 50	50 - 100	100 - 150	150 - 200	200 - 250	250 - 300
$N$	4	8	18	32	28	13
$p_i$	0.039	0.078	0.175	0.311	0.272	0.126
$v_i$ [m/s]	25	75	125	175	225	275

We note that  $\sum_i p_i = 1$ . We obtain

$$\langle v \rangle = \sum_i p_i v_i = 179.0 \frac{\text{m}}{\text{s}},$$

$$v_{\text{rms}} = \sqrt{\langle v^2 \rangle} = \sqrt{\sum_i p_i v_i^2} = \sqrt{36,020 \left(\frac{\text{m}}{\text{s}}\right)^2} = 190 \frac{\text{m}}{\text{s}}.$$

We find the mass of a Ne-atom:  $m = M/N = 20.2 \text{ u}$ ,

$$m = 20.2 \cdot 1.6605 \times 10^{-27} \text{ kg} = 3.35 \times 10^{-26} \text{ kg}.$$

The temperature determines the average kinetic energy of a gas molecule. Since a Ne atom has three degree of freedom, the average kinetic energy is given by  $3k_B T/2 = mv_{\text{rms}}^2/2$ . We solve for the temperature  $T = mv_{\text{rms}}^2/3k_B T$ ,

$$T = \frac{3.35 \times 10^{-26} \text{ kg} \cdot (190 \text{ m/s})^2}{3 \cdot 1.38 \times 10^{-23} \text{ J/K}} = 29.2 \text{ K}.$$

**Problem 2.21:** The volume of the balloon is given by:  $V = 1767.2 \text{ m}^3$ . The weight of the hot air inside the balloon follows  $W_{\text{hot}} = \rho_{\text{hot}} V g$ ,

$$W_{\text{hot}} = 1.12 \frac{\text{kg}}{\text{m}^3} \cdot 1767.2 \text{ m}^3 \cdot 9.8 \frac{\text{m}}{\text{s}^2} = 19,397 \text{ N}.$$

The buoyant force follows  $F_B = \rho_{\text{cold}} V g$ ,

$$F_B = 1.29 \frac{\text{kg}}{\text{m}^3} \cdot 1767.2 \text{ m}^3 \cdot 9.8 \frac{\text{m}}{\text{s}^2} = 22,341 \text{ N},$$

The weight of the load:  $W_{\text{load}} = m_{\text{load}} g$ ,

$$W_{\text{load}} = 212.1 \text{ kg} \cdot 9.8 \frac{\text{m}}{\text{s}^2} = 2079 \text{ N}.$$

The net force follows  $F_{\text{net}} = F_B - W_{\text{hot}} - W_{\text{load}}$ ,

$$F_{\text{net}} = 22,341 \text{ N} - 19,397 \text{ N} - 2,079 \text{ N} = 865 \text{ N}.$$

The total mass [cabin plus hot air] is given by:  $M = m_{\text{load}} + m_{\text{hot}}$ ,

$$M = 212 \text{ kg} + 1979 = 2191 \text{ kg}.$$

We thus get for the acceleration:  $a = F_{\text{net}}/M$ ,

$$a = \frac{865 \text{ N}}{2191 \text{ kg}} = 0.40 \frac{\text{m}}{\text{s}^2}.$$

Since  $h = at^2/2$ , we find the time to reach the top of the tower:  $t = \sqrt{2h/a}$ ,

$$t = \sqrt{\frac{2 \cdot 212 \text{ m}}{0.4 \text{ m/s}^2}} = 32.9 \text{ s},$$

that's about half a minute.

**Problem 2.22:** We find the table for the drop of the water level every 30-s time interval:

Time [s]	$\Delta h$ [cm]	$\Delta h/h$
0	-7.7	-0.285
30	-5.4	-0.290
60	-3.7	-0.280
90	-2.7	-0.284
120	-2.0	-0.294
150	-1.4	-0.291
180	-0.9	

Since  $\Delta h/h \simeq -0.3$ , the height of water column drops 30% during every 30-s time interval. We write  $\Delta t = 30 \text{ s}$ . Since  $\Delta h/h = -\Delta t/\tau$ , we find the time constant  $\tau = \Delta t(-\Delta h/h)$ ,

$$\tau = \frac{30 \text{ s}}{0.3} = 100 \text{ s}.$$



The height decays exponentially,  $h(t) = h_0 \exp(-t/\tau)$  so that

$$\ln\left(\frac{5 \text{ mm}}{260 \text{ mm}}\right) = -3.95 = -\frac{t}{100 \text{ s}}.$$

The time follows  $t = 395 \text{ s}$ , or about 6.5 minutes. The pressure difference across the horizontal pipe is the hydrostatic pressure in the bucket:  $\Delta P = \rho gh$ . The volume flow through the pipe decreases the height of the water inside the bucket:  $\Delta V = -A\Delta h$ . Inserted into “Ohm’s law” for the water flow through pipes:  $\Delta P = R\Delta V/\Delta t$ , we find  $\rho gh = R(-A\Delta h)/\Delta t$ , or

$$\frac{\Delta h}{h} = -\frac{\Delta t}{RA/\rho g},$$

i.e.,  $\Delta h/h$  is proportional to the elapsed time  $\Delta t$ . We find  $\tau = RA/\rho g$  so that the resistance of the pipe follows  $R = \tau \rho g/A$

$$R = \frac{100 \text{ s} \cdot 1000 \text{ kg/m}^3 \cdot 9.8 \text{ m/s}^2}{0.03 \text{ m}^2} = 3.3 \times 10^7 \frac{\text{Pa s}}{\text{m}^3}.$$

*Note:* The dynamic viscosity has unit  $[\eta] = \text{Pa s}$ . The unit for the resistance of the pipe  $[R] = \text{Pa s/m}^3 = [\eta]/[\text{Vol}]$ .

“I studied English for 16 years but...  
...I finally learned to speak it in just six lessons”  
Jane, Chinese architect

ENGLISH OUT THERE

Click to hear me talking before and after my unique course download

**Problem 2.23:** The forces on the ball are the weight  $W = (4\pi/3)a^3\rho_{\text{ball}}g$ , the buoyant force  $F_B = (4\pi/3)a^3\rho_{\text{glycerol}}g$ , and the drag  $F_{\text{drag}} = 6\pi a\eta v$ . When the ball descends at the terminal speed  $v_\infty$ , the net force on the ball is zero:  $F_{\text{net}} = (4\pi/3)a^3[\rho_{\text{ball}} - \rho_{\text{glycerol}}]g - 6\pi a\eta v_\infty = 0$ . We solve for the terminal speed  $v_\infty = 2a^2[\rho_{\text{ball}} - \rho_{\text{glycerol}}]/9\eta$ ,

$$v_\infty = \frac{2 \cdot (1.1 \times 10^{-2} \text{ m})^2 \cdot [2560 \text{ kg/m}^3 - 1261 \text{ kg/m}^3]}{9 \cdot 1.412 \text{ Pa s}} = 2.5 \times 10^{-2} \frac{\text{m}}{\text{s}},$$

or  $v_\infty = 2.5 \text{ cm/s}$ . The mass of the ball is given by  $m_{\text{ball}} = (4\pi/3)a^3\rho_{\text{ball}}$ . We write the acceleration  $a = \Delta v/\Delta t$ , and find from Newton's second law for the ball:  $\Delta v/\Delta t = (\rho_{\text{ball}} - \rho_{\text{glycerol}})g/\rho_{\text{ball}} - (9\eta/2a^2\rho_{\text{ball}})v$ . We insert  $\rho_{\text{ball}} - \rho_{\text{glycerol}} = 9\eta v_\infty/2a^2$ , and find

$$\frac{\Delta v}{\Delta t} = \frac{v_\infty - v}{\tau},$$

where the time constant is given by  $\tau = 2a^2\rho_{\text{ball}}/9\eta$ ,

$$\tau = \frac{2 \cdot (1.1 \times 10^{-2} \text{ m})^2 \cdot 2569 \text{ kg/m}^3}{9 \cdot 1.412 \text{ Pa s}} = 4.9 \times 10^{-2} \text{ s}.$$

We introduce the deviation from the terminal speed:  $\tilde{v} = v_\infty - v$ . We find  $\Delta\tilde{v} = -\Delta v$  so that  $\Delta\tilde{v}/\tilde{v} = -\Delta t/\tau$ . Thus, the time-dependence of  $\tilde{v}$  is exponential,  $\tilde{v} = \tilde{v}_0 \exp(-t/\tau)$ . We assume that the ball is released from rest  $v(0) = 0$  so that  $\tilde{v}_0 = v_\infty$ . We thus find  $v_\infty - v(t) = v_\infty \exp(-t/\tau)$ , or

$$v(t) = v_\infty (1 - e^{-t/\tau}).$$

The value of time constant  $\tau$  implies that the ball with 1.1 cm radius is descending at the terminal speed 49 ms after it was released. This time is essentially instantaneous on human time scales of seconds.

**Problem 2.24:** Total volume is  $V = 15 \cdot 0.5 \text{ L} = 7.5 \text{ L}$ . The partial pressure of oxygen is  $\Delta P_{\text{Oxygen}} = 0.2 \cdot 1.01 \times 10^5 \text{ Pa} = 2.0 \times 10^4 \text{ Pa}$ . The number of moles follows  $n = PV/RT$ ,

$$n = \frac{21 \text{ kPa} \cdot 7.5 \times 10^{-3} \text{ m}^3}{8.31 \text{ J/(mol K)} \cdot 293 \text{ K}} = 0.065 \text{ mol}.$$

Molecular mass of oxygen is  $M = 2 \times 16 \text{ g/mol} = 32 \text{ g/mol}$ . Thus the mass of oxygen follows:  $m = nM$ ,

$$m = 0.065 \text{ mol} \cdot 32 \frac{\text{g}}{\text{mol}} = 2.1 \text{ g}.$$

**Problem 2.25:** Heat pump: run engine [work  $W$ ] to remove heat from cold reservoir [outside] and dump heat into hot reservoir [inside!]:  $Q_c + W = Q_h$ . The coefficient of performance follows  $\text{COP} = Q_h/W$ . Since  $W = Q_h - Q_c$ .  $\text{COP} = 1/(1 - Q_c/Q_h) > 1$ . The lower temperature is  $T_c = 256 \text{ K}$  [zero degree Fahrenheit!] and the higher temperature is  $T_h = 293 \text{ K}$  [60 degrees Fahrenheit]. We assume a Carnot process so that  $Q_h/T_h = Q_c/T_c$  so that  $Q_c/Q_h = T_c/T_h$ ,

$$\text{COP} = \frac{1}{1 - 256 \text{ K}/293 \text{ K}} \simeq 8.$$

Compare with “space heater:”  $\text{COP} = 1$ . *Some technical background:* Heat is measured in “BTU” (British Thermal Unit) with  $1 \text{ BTU} = 1,055 \text{ J}$ . The supplied electrical energy is measured in Watt-hour with  $1 \text{ Wh} = 3,600 \text{ J}$ . The ratings of heat pumps is measured in HSPF’s [Heating Seasonal Performance Factor - HSPF]:

$$\text{COP} = \frac{1,055}{3,600} \cdot \text{HSPF} = \frac{1}{3.4} \cdot \text{HSPF}$$

*Note:* Commercial heat pumps have a HSPF of about 9.5. It needs to be greater than 8 for a tax credit! This corresponds to a COP of about 2.8.

**Problem 2.26:** The temperature at state 1 is given by

$$T_1 = \frac{2 \times 10^5 \text{ Pa} \cdot 50 \times 10^{-3} \text{ m}^3}{4 \text{ mol} \cdot 8.3 \text{ J}/(\text{mol K})} = 301 \text{ K}.$$

Since  $1 \rightarrow 2$  is isobaric  $P_1 = P_2$ , we find  $T_1/V_1 = T_2/V_2$  so that  $T_2 = (V_2/V_1)T_1$ ,

$$T_2 = 3 \cdot 301.2 \text{ K} = 904 \text{ K}.$$

Since  $2 \rightarrow 3$  is an adiabatic process and  $V_3 = V_1 = 50 \text{ L}$ , we find  $P_3 = (V_2/V_3)^{1.4} P_2$ ,

$$P_3 = 3^{1.4} \cdot 2 \text{ atm} = 9.3 \text{ atm}.$$

Since  $3 \rightarrow 1$  is isochoric  $V_3 = V_1$ , we find  $T_3 = (P_3/P_1)T_1$ ,

$$T_3 = \frac{9.3 \text{ atm}}{2.0 \text{ atm}} \cdot 301.2 \text{ K} = 1401 \text{ K}.$$

We obtain the graphs:

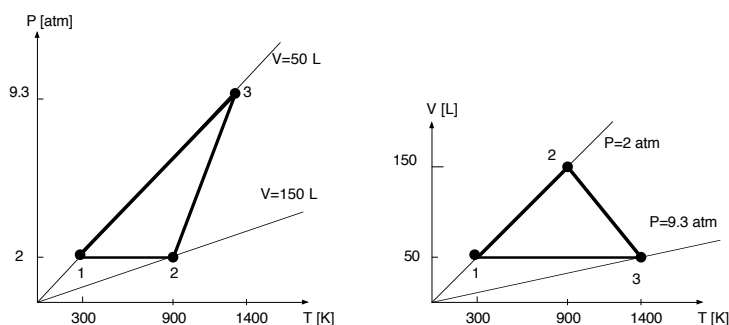

We calculate the work along the segments. For  $1 \rightarrow 2$ ,  $W_{12} = -P_1(V_2 - V_1)$ ,

$$W_{12} = -2.0 \times 10^5 \text{ Pa} \cdot 1.0 \times 10^{-1} \text{ m}^3 = -20.0 \text{ kJ} < 0,$$

and for  $2 \rightarrow 3$ ,  $W_{23} = (P_3V_3 - P_2V_2)/(\gamma - 1)$ ,

$$W_{23} = \frac{9.3 \times 10^5 \cdot 50 \times 10^{-3} \text{ m}^3 - 2.0 \times 10^5 \text{ Pa} \cdot 150 \times 10^{-3} \text{ m}^3}{1.4 - 1} = 41.25 \text{ kJ} > 0,$$

and for  $3 \rightarrow 1$ ,  $W_{31} = 0$ . The net work done *on* the gas is:  $W_{\text{net}} = W_{12} + W_{23} + W_{31}$ ,

$$W_{\text{net}} = -20.0 \text{ kJ} + 41.25 \text{ kJ} + 0 = 21.25 \text{ kJ} > 0.$$

We find the change in the internal energy:  $\Delta U_{ij} = (5/2)nR(T_j - T_i)$ ,

$$\begin{aligned}\Delta U_{12} &= \frac{5}{2} \cdot 4.0 \text{ mol} \cdot 8.3 \frac{\text{J}}{\text{mol} \cdot \text{K}} \cdot (904 \text{ K} - 301 \text{ K}) = 50 \text{ kJ}, \\ \Delta U_{23} &= \frac{5}{2} \cdot 4.0 \text{ mol} \cdot 8.3 \frac{\text{J}}{\text{mol} \cdot \text{K}} \cdot (1401 \text{ K} - 904 \text{ K}) = 41.25 \text{ kJ}, \\ \Delta U_{31} &= \frac{5}{2} \cdot 4.0 \text{ mol} \cdot 8.3 \frac{\text{J}}{\text{mol} \cdot \text{K}} \cdot (301 \text{ K} - 1401 \text{ K}) = -91.25 \text{ kJ}.\end{aligned}$$

The heat follows  $Q = \Delta U - W$ ,

$$\begin{aligned}Q_{12} &= 50 \text{ kJ} - (-20 \text{ kJ}) = 70 \text{ kJ} > 0, \\ Q_{23} &= 41.25 \text{ kJ} - 41.25 \text{ kJ} = 0, \\ Q_{31} &= 91.25 \text{ kJ} - 0 = -91.25 \text{ kJ} < 0.\end{aligned}$$

That is, heat is added as  $1 \rightarrow 2$ , while heat is removed as  $3 \rightarrow 1$ .  
We find the total heat added  $Q_{\text{net}} = Q_{12} + Q_{23} + Q_{31}$

$$Q_{\text{net}} = 70 \text{ kJ} + 0 + (-91.25 \text{ kJ}) = -21.25 \text{ kJ} < 0$$

Overall work is done on the gas and heat is removed from the gas: i.e., work is transformed into heat. The system operates as a *heat pump, refrigerator*, or.... In these examples, the net work  $W_{\text{net}}$  is ultimately “delivered” by the energy, as the appliance is plugged into the electric *outlet*.

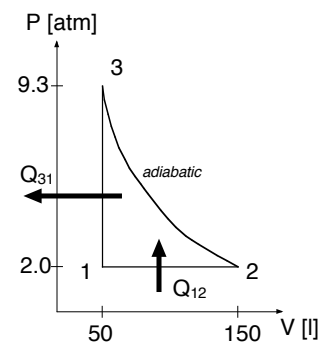



## Sharp Minds - Bright Ideas!

Employees at FOSS Analytical A/S are living proof of the company value - First - using new inventions to make dedicated solutions for our customers. With sharp minds and cross functional teamwork, we constantly strive to develop new unique products - Would you like to join our team?

FOSS works diligently with innovation and development as basis for its growth. It is reflected in the fact that more than 200 of the 1200 employees in FOSS work with Research & Development in Scandinavia and USA. Engineers at FOSS work in production, development and marketing, within a wide range of different fields, i.e. Chemistry, Electronics, Mechanics, Software, Optics, Microbiology, Chemometrics.

**We offer**  
A challenging job in an international and innovative company that is leading in its field. You will get the opportunity to work with the most advanced technology together with highly skilled colleagues.

Read more about FOSS at [www.foss.dk](http://www.foss.dk) - or go directly to our student site [www.foss.dk/sharpminds](http://www.foss.dk/sharpminds) where you can learn more about your possibilities of working together with us on projects, your thesis etc.

**Dedicated Analytical Solutions**

FOSS  
Slangerupgade 69  
3400 Hillerød  
Tel. +45 70103370  
[www.foss.dk](http://www.foss.dk)









**Problem 2.27:** We find the heat  $Q$  necessary to melt the ice:  $Q = mL$ ,

$$Q = 3.34 \times 10^5 \frac{\text{J}}{\text{kg}} \cdot 18 \times 10^{-3} \text{ kg} = 6,012 \text{ J}.$$

We find the entropy change  $\Delta S = Q/T$

$$\Delta S = \frac{6.012 \text{ J}}{273 \text{ K}} = 22.02 \frac{\text{J}}{\text{K}}.$$

We find the heat associated with the change in temperature of the melted water  $Q' = mc\Delta T$ ,

$$Q' = 18 \times 10^{-3} \text{ kg} \cdot 4,186 \frac{\text{J}}{\text{kg K}} \cdot 1 \text{ K} = 75.35 \text{ J}.$$

The corresponding entropy change follows:  $\Delta S' = Q'/T$ ,

$$\Delta S' = \frac{75.35 \text{ J}}{273 \text{ K}} = 0.28 \frac{\text{J}}{\text{K}}.$$

We find the ratio:

$$\frac{\Delta S}{\Delta S'} = \frac{22.0 \text{ J/K}}{0.28 \text{ J/K}} \simeq 78,$$

i.e., the entropy change during the melting of ice [i.e., during the phase transformation] is much larger than the entropy change during the gradual increase in the temperature. In ice, the individual atoms are “locked” into specific locations and then move freely after the melting has occurred.

**Problem 2.28:** For point A: We find  $P_A = 1.4 \text{ atm}$  and  $T_A = 300 \text{ K}$ . Use the ideal gas law to find  $V_A$  (recall that  $n = 1 \text{ mol}$ ):  $V_A = RT_A/P_A$ ,

$$V_A = \frac{8.3 \text{ J/K} \cdot 300 \text{ K}}{1.4 \times 10^5 \text{ Pa}} = 17.8 \text{ L}.$$

For point B: We find  $P_B = 1.4 \text{ atm}$  and  $T_B = 400 \text{ K}$ . Use the ideal gas law to find  $V_B$  (recall that  $n = 1 \text{ mol}$ ):  $V_B = RT_B/P_B$ ,

$$V_B = \frac{8.3 \text{ J/K} \cdot 400 \text{ K}}{1.4 \times 10^5 \text{ Pa}} = 23.7 \text{ L}.$$

For point C: We obtain  $V_C = V_B = 23.7 \text{ L}$  and  $T_C = 650 \text{ K}$ . Then  $P_C = RT_C/V_C$ ,

$$P_C = \frac{8.3 \text{ J/K} \cdot 650 \text{ K}}{23.7 \times 10^{-3} \text{ m}^3} = 2.3 \text{ atm}.$$

For point D: We obtain  $V_D = V_A = 17.8 \text{ L}$  and  $T_D = 650 \text{ K}$ . Then  $P_D = RT_D/V_D$ ,

$$P_D = \frac{8.3 \text{ J/K} \cdot 650 \text{ K}}{17.8 \times 10^{-3} \text{ m}^3} = 3.0 \text{ atm}.$$

We read-off that the net work is positive,  $W_{\text{net}} > 0$ ; the cycle is a refrigerator/heat pump. For  $A \rightarrow B$ , the work is  $W_{AB} = -P_A(V_B - V_A)$ ,

$$W_{AB} = -1.4 \text{ atm} \cdot (23.7 \text{ L} - 17.8 \text{ L}) = -826 \text{ J}.$$

We find the change in the internal energy:  $\Delta U_{AB} = (5/2)R(T_B - T_A)$ ,

$$\Delta U_{AB} = \frac{5}{2} 8.3 \frac{\text{J}}{\text{K}} \cdot (400 \text{ K} - 300 \text{ K}) = 2,075 \text{ J} > 0.$$

Since  $Q_{AB} = \Delta U_{AB} - W_{AB}$ , we find the heat added,

$$Q_{AB} = 2,075 \text{ J} - (-826 \text{ J}) = 2,901 \text{ J} > 0.$$

For  $B \rightarrow C$ : Since  $V_B = V_C$ , the volume change is zero  $\Delta V = 0$  so that the work is zero as well,  $W_{BC} = 0$ . We find the change in the internal energy:  $\Delta U_{BC} = (5/2)R(T_C - T_B)$ ,

$$\Delta U_{BC} = \frac{5}{2} 8.3 \frac{\text{J}}{\text{K}} \cdot (650 \text{ K} - 400 \text{ K}) = 5,118 \text{ J}.$$

We obtain the heat added  $Q_{BC} = \Delta U_{BC} - W_{BC}$ ,

$$Q_{BC} = 5,118 \text{ J} > 0.$$

For  $C \rightarrow D$ : we find  $P = RT_C/V$  so that  $W_{CD} = -RT_C \ln(V_D/V_C)$ ,

$$W_{CD} = -8.3 \frac{\text{J}}{\text{K}} \cdot 650 \text{ K} \cdot \ln\left(\frac{17.8 \text{ L}}{23.8 \text{ L}}\right) = 1,567 \text{ J} > 0.$$

Since  $T_C = T_D$ , the change in the internal energy follows  $\Delta U_{CD} = 0$  so that  $Q_{CD} = \Delta U_{CD} - W_{CD}$

$$Q_{CD} = -1,567 \text{ J} < 0.$$

For  $D \rightarrow A$ : the volume is constant  $V_A = V_D$  so that the volume change is zero  $\Delta V = 0$  and the work is zero  $W_{DA} = 0$ . We find the change in the internal energy:  $\Delta U_{DA} = (5/2)R(T_A - T_D)$ ,

$$\Delta U_{DA} = \frac{5}{2} 8.3 \frac{\text{J}}{\text{K}} \cdot (300 \text{ K} - 650 \text{ K}) = -7,263 \text{ J}.$$

We use the first law of thermodynamics:  $Q_{DA} = \Delta U_{DA} - W_{DA}$ ,

$$Q_{DA} = -7,263 \text{ J} < 0.$$

We find the *net* work,  $W_{\text{net}} = W_{AB} + W_{BC} + W_{CD} + W_{DA}$ :

$$W_{\text{net}} = (-826 \text{ J}) + 0 + (1,567 \text{ J}) + 0 = 741 \text{ J} > 0,$$

i.e., work is done *on* the gas. Let's check:  $\sum Q = Q_{AB} + Q_{BC} + Q_{CD} + Q_{DA}$ , or

$$\sum Q = 2,901 \text{ J} + 5,188 \text{ J} + (-1,567 \text{ J}) + (-7,263 \text{ J}) = -741 \text{ J} < 0.$$

The heat *added* to the gas follows:  $Q_{\text{in}} = Q_{AB} + Q_{BC}$ ,

$$Q_{\text{in}} = 2,901 \text{ J} + 5,118 \text{ J} = 8,089 \text{ J},$$

and for the heat *removed* from the gas:  $Q_{\text{out}} = |Q_{CD} + Q_{DA}|$ ,

$$Q_{\text{out}} = |(-1,567 \text{ J}) + (-7,263 \text{ J})| = 8,830 \text{ J}.$$

(i) We interpret the cycle as a *refrigerator*; then the COP follows  $\text{COP} = Q_{\text{in}}/W_{\text{net}}$ ,

$$\text{COP} = \frac{8,089 \text{ J}}{741 \text{ J}} \simeq 11 \quad (\text{refrigerator}).$$

(ii) We interpret the cycle as a *heat pump*; then the COP follows  $\text{COP} = Q_{\text{out}}/W_{\text{net}}$ ,

$$\text{COP} = \frac{8,830 \text{ J}}{741 \text{ J}} \simeq 12 \quad (\text{heat pump}).$$

**Problem 2.29:** If the heat conducting rods are parallel, the same temperature difference applies to both rods. We find the heat flux across the two rods:  $Q/t = kA(\Delta T/L)$ ,

$$\begin{aligned} \left(\frac{Q}{t}\right)_1 &= 250 \frac{\text{J}}{\text{s m}^\circ\text{C}} \cdot 5.4 \times 10^{-4} \text{ m}^2 \cdot \frac{72^\circ\text{C} - 28^\circ\text{C}}{0.56 \text{ m}} = 10.6 \frac{\text{J}}{\text{s}}, \\ \left(\frac{Q}{t}\right)_2 &= 380 \frac{\text{J}}{\text{s m}^\circ\text{C}} \cdot 5.4 \times 10^{-4} \text{ m}^2 \cdot \frac{72^\circ\text{C} - 28^\circ\text{C}}{0.56 \text{ m}} = 16.1 \frac{\text{J}}{\text{s}}, \end{aligned}$$

The total heat flux follows  $(Q/t)_{\text{parallel}} = (Q/t)_1 + (Q/t)_2$ ,

$$\left(\frac{Q}{t}\right)_{\text{parallel}} = 10.6 \frac{\text{J}}{\text{s}} + 16.1 \frac{\text{J}}{\text{s}} = 26.7 \frac{\text{J}}{\text{s}}.$$

If the heat conducting rods are *in series*, the same heat flux is transported in both rods. We introduce the temperature  $T^*$  at the connection between the two rods. Then  $k_1(T_h - T^*)/L = k_2(T^* - T_c)/L$  so that  $k_1(T_h - T^*) = k_2(T^* - T_c)$ . We solve for the temperature  $T^* = (k_1T_h + k_2T_c)/(k_1 + k_2)$ ,

$$T^* = \frac{250 \text{ J}/(\text{s m}^\circ\text{C}) \cdot 72^\circ + 380 \text{ J}/(\text{s m}^\circ\text{C}) \cdot 28^\circ}{250 \text{ J}/(\text{s m}^\circ\text{C}) + 380 \text{ J}/(\text{s m}^\circ\text{C})} = 45.5^\circ\text{C}.$$

We calculate the heat flux through the rod 1:

$$\left(\frac{Q}{t}\right)_1 = 250 \frac{\text{J}}{\text{s m}^\circ\text{C}} \cdot 5.4 \times 10^{-4} \text{ m}^2 \cdot \frac{72^\circ\text{C} - 45.5^\circ\text{C}}{0.56 \text{ m}} = 6.4 \frac{\text{J}}{\text{s}},$$

and the heat flux through rod 2:

$$\left(\frac{Q}{t}\right)_2 = 380 \frac{\text{J}}{\text{s m}^\circ\text{C}} \cdot 5.4 \times 10^{-4} \text{ m}^2 \cdot \frac{45.4^\circ\text{C} - 28^\circ\text{C}}{0.56 \text{ m}} = 6.4 \frac{\text{J}}{\text{s}},$$

Thus, we recover  $(Q/t)_1 = (Q/t)_2$ , as it should. Thus, the total heat flux is

$$\left(\frac{Q}{t}\right)_{\text{series}} = 6.4 \frac{\text{J}}{\text{s}}.$$

It is instructive to repeat the calculation but now with rod 2 connecting to the hot reservoir and rod 1 connected to cold reservoir. We then find the temperature at the connection between the two rods  $\tilde{T}^* = 54.5$ , so that  $\tilde{T}^* \neq T^*$ . We find  $(\tilde{Q}/t)_{\text{series}} = (Q/t)_{\text{series}}$ . That is, the arrangement of the conducting rods is irrelevant.

**Problem 2.30:** The volume flow is given by  $Q = V/t$

$$Q = \frac{15.14 \times 10^{-3} \text{ m}^3}{25 \text{ s}} = 6.1 \times 10^{-4} \frac{\text{m}^3}{\text{s}}.$$

The cross section of the hose is  $A = \pi r^2 = \pi(6.35 \times 10^{-3} \text{ m})^2 = 1.27 \times 10^{-4} \text{ m}^2$ . Since  $Q = Av$ , we obtain the speed of water in the hose,  $v = Q/A$ ,

$$v = \frac{6.1 \times 10^{-4} \text{ m}^3/\text{s}}{1.27 \times 10^{-4} \text{ m}^2} = 4.8 \frac{\text{m}}{\text{s}}.$$

The water in the stream undergoes projectile motion (neglecting the spreading of the stream). We find the biggest range when we aim the stream at the angle  $\theta_0 = 45^\circ$ . We find  $R = v^2/g$ ,

$$R = \frac{(4.8 \text{ m/s})^2}{9.8 \text{ m/s}^2} = 2.4 \text{ m}.$$

The range is given by  $R' = 8.0 \text{ m}$ . Thus the speed leaving the hose follows  $v' = \sqrt{R'g}$ ,

$$v' = \sqrt{8.0 \text{ m} \cdot 9.8 \frac{\text{m}}{\text{s}^2}} = 8.9 \frac{\text{m}}{\text{s}}.$$

We use the equation of continuity  $Q = Av = A'v'$  so that  $A' = (v/v')A$ ,

$$A' = \frac{2.4 \text{ m/s}}{8.9 \text{ m/s}} \cdot 1.27 \times 10^{-4} \text{ m}^2 = 0.34 \times 10^{-4} \text{ m}^2.$$

Since  $\chi = A'/A = 0.34 \text{ cm}^2/1.27 \text{ cm}^2 = 0.26$ , we need to cover about 75% of the hose diameter. We use Bernoulli's equation  $P + \rho v^2/2 = P' + \rho(v')^2/2$ , so that the pressure difference follows  $P' - P = (\rho/2)[v^2 - (v')^2]$ ,

$$P' - P = \frac{1,000 \text{ kg/m}^3}{2} \left[ \left(4.8 \frac{\text{m}}{\text{s}}\right)^2 - \left(8.9 \frac{\text{m}}{\text{s}}\right)^2 \right] = -36.7 \text{ kPa},$$

that is, the water pressure drops.



**Problem 3.1:** The coordinate of the electron is:  $x_e = 0.31 \text{ nm} \cdot \cos 63^\circ = 0.14 \text{ nm}$  and  $y_e = 0.31 \text{ nm} \cdot \sin 63^\circ = 0.27 \text{ nm}$ . We find the radius between sodium and electron follows  $r_{\text{Na}} = \sqrt{(0.115 \text{ nm} + 0.14 \text{ nm})^2 + (0.27 \text{ nm})^2} = 0.37 \text{ nm}$ . The magnitude of the force follows:

$$F_{\text{Na}} = 8.99 \times 10^9 \frac{\text{N m}^2}{\text{C}^2} \frac{(1.602 \times 10^{-19} \text{ C})^2}{(3.7 \times 10^{-10} \text{ m})^2} = 1.70 \text{ nN}.$$

The direction follows

$$\tan \theta_1 = \frac{0.27 \text{ nm}}{0.255 \text{ nm}} = 1.06,$$

so that  $\theta_1 = 46.6^\circ$ . Similar for the chlorine: we find the radius between chlorine and electron:  $r_{\text{Cl}} = \sqrt{(-0.115 \text{ nm} + 0.14 \text{ nm})^2 + (0.27 \text{ nm})^2} = 0.27 \text{ nm}$ . The magnitude of the force follows:

$$F_{\text{Cl}} = 8.99 \times 10^9 \frac{\text{N m}^2}{\text{C}^2} \frac{(1.609 \times 10^{-19} \text{ C})^2}{(2.7 \times 10^{-10} \text{ m})^2} = 3.2 \text{ nN}.$$

The direction follows

$$\tan \theta_2 = \frac{0.27 \text{ nm}}{0.025 \text{ nm}} = 10.8,$$

so that  $\theta_2 = 84.7^\circ$ . We find the  $x$  and  $y$  components

$$\begin{aligned} F_x &= 1.07 \text{ nN} \cdot (-\cos 46.6^\circ) + 3.2 \text{ nN} \cdot \cos 84.7^\circ = -0.44 \text{ nN}, \\ F_y &= 1.07 \text{ nN} \cdot (-\sin 46.6^\circ) + 3.2 \text{ nN} \cdot \sin 84.7^\circ = 2.42 \text{ nN}. \end{aligned}$$

Thus for the magnitude of the force

$$F = \sqrt{(-0.44 \text{ nN})^2 + (2.42 \text{ nN})^2} = 2.46 \text{ nN}.$$

We find

$$\tan \theta = \frac{2.42 \text{ nN}}{(-0.44 \text{ nN})} = -5.54,$$

so that  $\theta = 100.2^\circ$ .

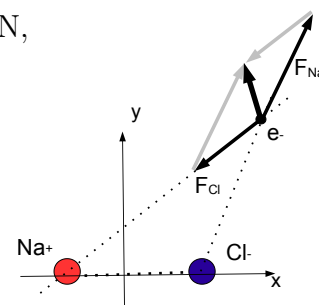

**Problem 3.2:** We find the kinetic energy of the hydrogen ion  $\text{KE} = m_{\text{H}}v_{\text{H}}^2/2$ ,

$$\text{KE}_i = \frac{1}{2} 1.67 \times 10^{-27} \text{ kg} \left( 20,500 \frac{\text{m}}{\text{s}} \right)^2 = 35.1 \times 10^{-20} \text{ J},$$

The separation of the two ions is  $d = 5.1 \times 10^{-9} \text{ m}$ . The electrostatic potential energy between them follows:  $\text{EPE} = kq_{\text{H}}q_{\text{He}}/d^2$ ,

$$\text{EPE}_i = 8.99 \times 10^9 \frac{\text{N m}^2}{\text{C}^2} \cdot \frac{1.602 \times 10^{-19} \text{ C} \cdot (2 \cdot 1.602 \times 10^{-19} \text{ C})}{5.1 \times 10^{-9} \text{ m}} = 9.2 \times 10^{-20} \text{ J}.$$

The total energy follows:  $E_{\text{tot}} = \text{KE}_i + \text{EPE}_i$ ,

$$E_{\text{tot}} = 35.1 \times 10^{-20} \text{ J} + 9.2 \times 10^{-20} \text{ J} = 44.3 \times 10^{-20} \text{ J}.$$

The total momentum is given by:  $P_{\text{tot}} = Mv_{\text{CoM}} = m_{\text{He}}v_{\text{He}} + m_{\text{H}}v_{\text{H}}$  so that the velocity follows

$$v_{\text{CoM}} = \frac{1 \text{ u}}{4 \text{ u} + 1 \text{ u}} \cdot 20,500 \frac{\text{m}}{\text{s}} = 4,100 \frac{\text{m}}{\text{s}}.$$

The kinetic energy of the center-of-mass:

$$KE_{\text{CoM}} = \frac{1}{2} 5 \cdot 1.67 \times 10^{-27} \text{ kg} \left( 4,100 \frac{\text{m}}{\text{s}} \right)^2 = 7.0 \times 10^{-20} \text{ J}.$$

Because the  $\text{He}^{2+}$ - and  $\text{H}^+$  interact via action-reaction-pair forces, the CoM velocity is constant and  $KE_{\text{CoM}} = \text{const}$ . Initially, the two ions travel towards each other, reach the closest separation, and then the reverse direction and move away from each other. The velocity of the *relative* motion is zero at the moment of closest approach. The maximum electrostatic potential energy then follows  $EPE_{\text{max}} = E_{\text{tot}} - KE_{\text{CoM}}$ ,

$$EPE_{\text{max}} = 44.3 \times 10^{-20} \text{ J} - 7.0 \times 10^{-20} \text{ J} = 37.3 \times 10^{-20} \text{ J}$$

The minimum distance follows  $EPE_{\text{max}} = kq_{\text{He}}q_{\text{H}}/r_{\text{min}}$  so that  $r_{\text{min}} = kq_{\text{H}}q_{\text{He}}/EPE_{\text{max}}$ .

$$r_{\text{min}} = 8.99 \times 10^9 \frac{\text{Nm}^2}{\text{C}^2} \cdot \frac{(2 \cdot 1.602 \times 10^{-19} \text{ C}) \cdot 1.602 \times 10^{-19} \text{ C}}{37.3 \times 10^{-20} \text{ J}} = 1.25 \times 10^{-9} \text{ m},$$

or  $r_{\text{min}} = 1.25 \text{ nm}$ .

**gaiTeye**  
Challenge the way we run

**EXPERIENCE THE POWER OF  
FULL ENGAGEMENT...**

**RUN FASTER.  
RUN LONGER..  
RUN EASIER...**

**READ MORE & PRE-ORDER TODAY  
WWW.GAITEYE.COM**

**Problem 3.3:** The coordinate of the oxygen atom:  $y_O = 9.42 \times 10^{-11} \text{ m} \cdot \cos 53^\circ = 5.7 \times 10^{-11} \text{ m}$ . We find the distance between the oxygen and  $P$ :  $r_O = 1.1 \times 10^{-10} \text{ m} + 0.57 \times 10^{-10} \text{ m}$ . We find  $q_O = 0.67 \cdot 1.602 \times 10^{-19} \text{ C} = 1.078 \times 10^{-19} \text{ C}$ . The force on the electron exerted by the oxygen ion follows

$$|\vec{F}_O| = \frac{8.99 \times 10^9 \text{ Nm}^2/\text{C}^2 \cdot 1.078 \times 10^{-19} \text{ C} \cdot 1.602 \times 10^{-19} \text{ C}}{(1.67 \times 10^{-10} \text{ m})^2} = 5.6 \times 10^{-9} \text{ N}.$$

We find the force:  $\vec{F}_O = -5.6 \times 10^{-9} \text{ N} \hat{j}$  (i.e., directed *downwards*). We obtain the distance between a hydrogen atom and the point  $P$ :

$$r_H = \sqrt{(9.42 \times 10^{-11} \text{ m} \cdot \sin 53^\circ)^2 + (1.1 \times 10^{-10} \text{ m})^2} = 1.33 \times 10^{-10} \text{ m}.$$

The charge on a hydrogen atom:  $q_H = 0.335 \cdot 1.602 \times 10^{-19} \text{ C} = 0.539 \times 10^{-19} \text{ C}$ . We find the magnitude of the force on the electron exerted by a hydrogen ion:

$$|\vec{F}_H| = \frac{8.99 \times 10^9 \text{ Nm}^2/\text{C}^2 \cdot 0.539 \times 10^{-19} \text{ C} \cdot 1.602 \times 10^{-19} \text{ C}}{(1.33 \times 10^{-10} \text{ m})^2} = 4.4 \times 10^{-9} \text{ N}.$$

The angle  $\alpha$  is given by:

$$\tan \alpha = \frac{9.42 \times 10^{-11} \text{ m} \cdot \sin 53^\circ}{1.1 \times 10^{-10} \text{ m}} = 0.68$$

so that  $\alpha = 34.4^\circ$ . We find the force due to the two hydrogen ions:

$$\vec{F}_H = 2 \cdot \cos 34.4^\circ \cdot 4.4 \times 10^{-9} \text{ N} = 7.3 \times 10^{-9} \text{ N}$$

so that  $\vec{F}_H = 7.3 \times 10^{-9} \text{ N} \hat{j}$  (i.e., directed *upwards*).

We find the net force  $\vec{F}_{\text{net}} = \vec{F}_O + \vec{F}_H$ ,

$$\vec{F}_{\text{net}} = -4.4 \times 10^{-9} \text{ N} \hat{j} + 7.3 \times 10^{-9} \text{ N} \hat{j} = 2.9 \times 10^{-9} \text{ N} \hat{j}.$$

That is, the net force is directed *upwards*: the electron is *attracted* to the water molecule, even though the net charge of the water molecule is zero.

**Problem 3.4:** The electrostatic force is attractive so that an additional, *repulsive* force maintains the separation between the ions. We find the bond force when the charges are in equilibrium from the Coulomb force between charges  $\pm\delta$  separated by the distance  $l_0$ :  $F_{\text{bond}}^0 = k\delta^2/l_0^2$ ,

$$F_{\text{bond}}^0 = 8.99 \times 10^9 \frac{\text{Nm}^2}{\text{C}^2} \cdot \frac{(0.18 \cdot 1.602 \times 10^{-19} \text{ C})^2}{(1.27 \times 10^{-10} \text{ m})^2} = 0.46 \text{ nN}.$$

We find the Coulomb force between ions when the molecule is stretched:  $l_0 \rightarrow l$ :  $F'_{\text{ion}} = k\delta^2/l^2$ ,

$$F'_{\text{ion}} = 8.99 \times 10^9 \frac{\text{Nm}^2}{\text{C}^2} \cdot \frac{(0.18 \cdot 1.602 \times 10^{-19} \text{ C})^2}{(1.34 \times 10^{-10} \text{ m})^2} = 0.42 \text{ nN}.$$

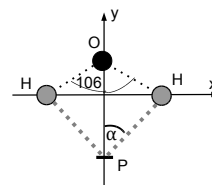

The electric force on the molecule in the external electric field  $E$  is given by  $F_{\text{ext}} = 2 \delta E$ ,

$$F_{\text{ext}} = 2 \cdot 0.18 \cdot 1.602 \times 10^{-19} \text{ C} \cdot 65.0 \times 10^9 \frac{\text{V}}{\text{m}} = 3.74 \text{ nN}.$$

The sum of the Coulomb force and the external force acting on the molecule is balanced by the a modified bond force  $F'_{\text{bond}} = F'_{\text{ion}} + F_{\text{ext}}$  so that

$$F'_{\text{bond}} = 3.74 \text{ nN} + 0.42 \text{ nN} = 4.16 \text{ nN}.$$

The increase in the bond force is modeled by an “effective” spring acting along the bond:  
 $F_{\text{spring}} = F'_{\text{bond}} - F_{\text{bond}}$ ,

$$F_{\text{spring}} = 4.16 \text{ nN} - 0.46 \text{ nN} = 3.7 \text{ nN}.$$

Since the elastic force is proportional to the stretch:  $F_{\text{spring}} = \mathcal{K}(l - l_0)$ , the spring constant follows  $\mathcal{K} = F_{\text{spring}}/(l - l_0)$ ,

$$\mathcal{K} = \frac{3.7 \times 10^{-9} \text{ N}}{7.0 \times 10^{-12} \text{ m}} = 525 \frac{\text{N}}{\text{m}}.$$

This is a reasonable value for the elastic properties of chemical bonds.

**The Wake**  
the only emission we want to leave behind

Low-speed Engines Medium-speed Engines Turbochargers Propellers **Propulsion Packages** PrimeServ

The design of eco-friendly marine power and propulsion solutions is crucial for MAN Diesel & Turbo. Power competencies are offered with the world's largest engine programme – having outputs spanning from 450 to 87,220 kW per engine. Get up front! Find out more at [www.mandieselturbo.com](http://www.mandieselturbo.com)

Engineering the Future – since 1758.  
**MAN Diesel & Turbo**



Click on the ad to read more

**Problem 3.5:** We find the time for the free fall of the dust particle inside the capacitor:  $0.13 \text{ m} = gt_{\text{air}}^2/2$ , so that for the time:

$$t_{\text{air}} = \sqrt{\frac{2 \cdot 0.13 \text{ m}}{9.8 \text{ m/s}^2}} = 0.163 \text{ s}.$$

From the motion along the horizontal  $\Delta x = 7.0 \cdot 10^{-3} \text{ m} = at_{\text{air}}^2/2$ . The acceleration along the horizontal follows  $t_{\text{air}} = 2\Delta x/at_{\text{air}}^2$ :

$$a = \frac{2 \cdot 7.0 \times 10^{-3} \text{ m}}{(0.163 \text{ s})^2} = 0.53 \frac{\text{m}}{\text{s}^2}.$$

We find the force along the vertical  $F_v = ma = 16e \cdot E$  so that the electric field follows:  $E = ma/16e$ ,

$$E = \frac{7.3 \times 10^{-14} \text{ kg} \cdot 0.53 \text{ m/s}^2}{16 \cdot 1.602 \times 10^{-19} \text{ C}} = 14,963 \frac{\text{N}}{\text{C}}.$$

The electric field is directed towards the *right*. Since  $E = \sigma/\epsilon_0$ , the surface charge density follows:  $\sigma = \epsilon_0 E$ ,

$$\sigma = 8.85 \times 10^{-12} \frac{\text{C}^2}{\text{N m}^2} \cdot 14,963 \frac{\text{N}}{\text{C}} = 1.32 \times 10^{-7} \frac{\text{C}}{\text{m}^2}.$$

We find the charge on the capacitor  $Q = \sigma A$ ,

$$Q = 1.32 \times 10^{-7} \frac{\text{C}}{\text{m}^2} \cdot (0.13 \text{ m})^2 = 2.23 \text{ nC}.$$

The left (right) plate is positively (negatively) charged.

**Problem 3.6:** The distances of the two charges to the point  $P$  are given by:

$$r_1 = \sqrt{(5.3 \text{ cm})^2 + (5.1 \text{ cm})^2} = 7.4 \text{ cm},$$

$$r_2 = \sqrt{(6.9 \text{ cm})^2 + (5.1 \text{ cm})^2} = 8.6 \text{ cm}.$$

The electrostatic potential at the point  $P$  follows:  $V = k(Q_1/r_1 + Q_2/r_2)$ . Since  $V = 0$ , we find the charge  $Q_2 = -Q_1(r_2/r_1)$

$$Q_2 = -(-3.8 \text{ nC}) \frac{8.5 \text{ cm}}{7.4 \text{ cm}} = +4.4 \text{ nC}.$$

We find the electric fields at the point  $P$  produced by the two charges  $|\vec{E}_i| = k|Q_i|/r_i^2$ :

$$|\vec{E}_1| = 8.99 \times 10^9 \frac{\text{Nm}^2}{\text{C}^2} \cdot \frac{3.8 \times 10^{-9} \text{ C}}{(0.074 \text{ m})^2} = 6245 \frac{\text{N}}{\text{C}}$$

$$|\vec{E}_2| = 8.99 \times 10^9 \frac{\text{Nm}^2}{\text{C}^2} \cdot \frac{4.4 \times 10^{-9} \text{ C}}{(0.086 \text{ m})^2} = 5354 \frac{\text{N}}{\text{C}}$$

The  $x$ - and  $y$ - components of the electric field  $\vec{E}_1$  are given by:

$$E_{1,x} = 6245 \frac{\text{N}}{\text{C}} \cdot \frac{5.3 \text{ cm}}{7.4 \text{ cm}} = 4473 \frac{\text{N}}{\text{C}}, \quad E_{1,y} = -6245 \frac{\text{N}}{\text{C}} \cdot \frac{5.1 \text{ cm}}{7.4 \text{ cm}} = -4304 \frac{\text{N}}{\text{C}},$$

and the  $x$ - and  $y$ - components of the electric field  $\vec{E}_2$ :

$$E_{2,x} = 5354 \frac{\text{N}}{\text{C}} \cdot \frac{6.8 \text{ cm}}{8.6 \text{ cm}} = 4233 \frac{\text{N}}{\text{C}}, \quad E_{2,y} = 5354 \frac{\text{N}}{\text{C}} \cdot \frac{5.1 \text{ cm}}{8.6 \text{ cm}} = 3175 \frac{\text{N}}{\text{C}}.$$

We then find for the total electric field:  $\vec{E} = \vec{E}_1 + \vec{E}_2$ :

$$E_x = 4473 \frac{\text{N}}{\text{C}} + 4233 \frac{\text{N}}{\text{C}} = 8706 \frac{\text{N}}{\text{C}},$$

$$E_y = -4304 \frac{\text{N}}{\text{C}} + 3175 \frac{\text{N}}{\text{C}} = -1129 \frac{\text{N}}{\text{C}}.$$

The magnitude of the total electric field:  $E = \sqrt{E_x^2 + E_y^2}$  follows:

$$E = \sqrt{\left(8706 \frac{\text{N}}{\text{C}}\right)^2 + \left(-1129 \frac{\text{N}}{\text{C}}\right)^2} = 8779 \frac{\text{N}}{\text{C}}$$

and for the direction:  $\tan \theta = E_y/E_x$ ,

$$\tan \theta = \frac{-1129 \text{ N/C}}{8706 \text{ N/C}} = -0.13,$$

so that  $\theta = -7.4^\circ$ .

**Problem 3.7:** Since  $C = Q/V$ , the charge on the capacitor follows  $Q = CV$ ,

$$Q_0 = 8.0 \times 10^{-6} \text{ F} \cdot 6.0 \text{ V} = 4.8 \times 10^{-5} \text{ C}.$$

The electrostatic potential energy stored in the capacitor follows  $U_E = CV^2/2$

$$U_{E,0} = \frac{1}{2} 8.0 \times 10^{-6} \text{ F} \cdot (6.0 \text{ V})^2 = 1.44 \times 10^{-4} \text{ J}.$$

The magnetic energy inside the inductor is given by  $U_M = (1/2)LI^2$ . Total energy in the  $LC$ -circuit is the sum of electric and magnetic energy  $U_{\text{tot}} = U_{E,0} = U_E + U_M$ ; since  $U_E = U_M = U_{E,0}/2$ . The electrostatic energy is given by  $U_E = Q_{1/2}^2/2C = 1.44 \times 10^{-4} \text{ J}/2$ , so that the charge follows  $Q_{1/2} = \sqrt{2CU_E}$ ,

$$Q_{1/2} = \sqrt{8.0 \times 10^{-6} \text{ F} \cdot 1.44 \times 10^{-4} \text{ J}} = 3.4 \times 10^{-5} \text{ C}$$

Similarly, the magnetic energy determines the current  $U_M = LI_{1/2}^2/2 = 1.44 \times 10^{-4} \text{ J}/2$ , we find  $I_{1/2} = \sqrt{2U_M/L}$ ,

$$I_{1/2} = \sqrt{\frac{1.44 \times 10^{-4} \text{ J}}{2.3 \times 10^{-3} \text{ H}}} = 0.25 \text{ A}.$$

We find the (angular) frequency of the  $LC$ -circuit:  $\omega_0 = 1/\sqrt{LC}$ , or

$$\omega_0 = \frac{1}{\sqrt{8.0 \times 10^{-6} \text{ F} \cdot 2.3 \times 10^{-3} \text{ H}}} = 7.4 \text{ kHz}.$$

The period follows  $T = 2\pi/\omega_0$ ,

$$T = \frac{2\pi}{7.4 \times 10^3 \text{ Hz}} = 0.852 \text{ ms.}$$

We find the ratio:  $Q_{1/2}/Q_0 = (3.4 \times 10^{-5} \text{ C})/(4.8 \times 10^{-5} \text{ C}) = 1/\sqrt{2}$ . Since  $Q(t_{1/2}) = Q_0 \cos(\omega_0 t_{1/2})$ , we find  $\omega_0 t_{1/2} = (2\pi/T)t_{1/2} = \pi/4$  so that the time follows  $t_{1/2} = T/8$

$$t_{1/2} = \frac{0.852 \text{ ms}}{8} = 0.106 \text{ ms.}$$

**Problem 3.8:** We use  $d_1 = 0.04 \text{ m}$  is the distance between the point  $P$  and the infinitely long wire  $I_1$ . The magnitude of the magnetic field follows

$$B_1 = 2 \times 10^{-7} \frac{\text{T m}}{\text{A}} \cdot \frac{3.1 \text{ A}}{0.04 \text{ m}} = 15.5 \mu\text{T}.$$

The magnetic field is directed along the  $+y$ -direction:

$$\vec{B}_1 = 15.5 \mu\text{T } \hat{y}.$$

The magnetic field  $\vec{B}_2$  is given by  $\vec{B}_2 = \vec{B} - \vec{B}_1$ , or

$$\vec{B}_2 = 18.2 \mu\text{T } \hat{x} + 5.1 \mu\text{T } \hat{y} - 15.5 \mu\text{T } \hat{y} = 18.2 \mu\text{T } \hat{x} - 10.4 \mu\text{T } \hat{y}.$$

We find the magnitude  $|\vec{B}_2| = \sqrt{B_{2,x}^2 + B_{2,y}^2}$ ,

$$|\vec{B}_2| = \sqrt{(18.2 \mu\text{T})^2 + (-10.4 \mu\text{T})^2} = 21.0 \mu\text{T},$$

and for the direction:  $\tan \theta_2 = B_{y,2}/B_{x,2}$ ,

$$\tan \theta_2 = \frac{-10.4 \mu\text{T}}{18.2 \mu\text{T}} = -0.571,$$

so that  $\theta = -29.7^\circ$ . We find  $x_2 = 4 \text{ cm} \cdot \tan 29.7^\circ = 2.3 \text{ cm}$ .

The distance between the current  $I_2$  and the point  $P$  follows:

$$d_2 = \frac{4.0 \text{ cm}}{\cos 29.7^\circ} = 4.6 \text{ cm}.$$

The current  $I_2$  follows from  $|\vec{B}_2| = \mu_0 I_2 / 2\pi d_2$  so that  $I_2 = 2\pi |\vec{B}_2| d_2 / \mu_0$ ,

$$I_2 = \frac{21.0 \times 10^{-6} \text{ T} \cdot 0.046 \text{ m}}{2.0 \times 10^{-7} \text{ Tm/A}} = 4.84 \text{ A}.$$

We use the second RHR to find that the current  $I_2$  is directed *out-of-the-page*.

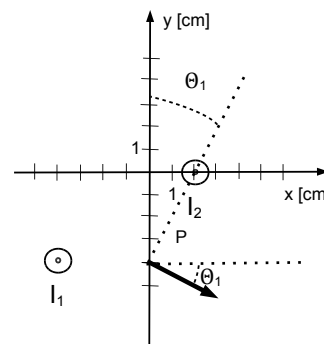

**Problem 3.9:** We label the circuit and write down the junction rule:

$$I_1 + I_2 = I_3.$$

and the loop rule for #1 and #2:

$$\begin{aligned} 8 - 5 &= 4 I_1 - 1 I_2, \\ 5 &= 1 I_2 + 3 I_3. \end{aligned}$$

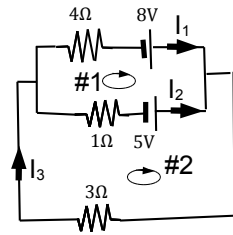

We insert  $I_3 = I_1 + I_2$  into the loop equations and find after some re-arrangements:

$$\begin{aligned} 12 &= 16 I_1 - 4 I_2, \\ 5 &= 3 I_1 + 4 I_2. \end{aligned}$$

We find  $17 = 19 \cdot I_1$  or  $I_1 = 0.89 \text{ A}$ . Then  $3 = 4 \cdot 0.89 - I_2$  so that  $I_2 = 0.58 \text{ A}$ . The current  $I_3$  follows  $I_3 = 0.89 \text{ A} + 0.58 \text{ A} = 1.47 \text{ A}$ . The power delivered by the two batteries follows:

$$P_{\text{batt}} = 8 \text{ V} \cdot 0.89 \text{ A} + 5.0 \text{ V} \cdot 0.58 \text{ A} = 10.0 \text{ W}.$$

and the power dissipated in the circuit:

$$P_{\text{dissip}} = 4 \Omega \cdot (0.89 \text{ A})^2 + 1 \Omega \cdot (0.58 \text{ A})^2 + 3 \Omega \cdot (1.47 \text{ A})^2 = 10.0 \text{ W}.$$

Then the power delivered by the batteries is equal to the dissipated power  $P_{\text{batt}} = P_{\text{dissip}}$ .

I joined MITAS because  
I wanted **real responsibility**

The Graduate Programme  
for Engineers and Geoscientists  
[www.discovermitas.com](http://www.discovermitas.com)



Real work  
International opportunities  
Three work placements



**Month 16**  
I was a construction  
supervisor in  
the North Sea  
advising and  
helping foremen  
solve problems







**Problem 3.10:** We set the electric and magnetic forces equal to each other  $ev_p B = eE$  and solve for the electric field:  $E = v_p B$ ,

$$E = 1.42 \times 10^5 \frac{\text{m}}{\text{s}} \cdot 0.52 \text{ T} = 7.4 \times 10^4 \frac{\text{N}}{\text{C}}.$$

The magnetic force is directed upwards [ $+y$ -axis] so that the electric force is directed downwards - thus the electric field is also directed *downwards* [i.e., directed along  $-y$ -direction]. We conclude that the top plate is at the higher potential. The potential difference follows  $V_{\text{top}} - V_{\text{bottom}} = E d$ ,

$$V_{\text{top}} - V_{\text{bottom}} = 7.4 \times 10^4 \frac{\text{N}}{\text{C}} \cdot 0.025 \text{ m} = 1.85 \text{ kV}.$$

We find the capacitance  $C = \epsilon_0 A/d$ :

$$C = 8.85 \times 10^{-12} \frac{\text{C}^2}{\text{Nm}^2} \cdot \frac{(0.092 \text{ m})^2}{0.025 \text{ m}} = 3.0 \times 10^{-12} \text{ F},$$

so that the charge on the capacitor follows  $Q = CV$ , or

$$Q = 3.0 \times 10^{-12} \text{ F} \cdot 1.85 \times 10^3 \text{ V} = 5.6 \times 10^{-9} \text{ C}.$$

The electric field density follows:  $u_E = \epsilon_0 E^2/2$ ,

$$u_E = \frac{8.85 \times 10^{-12} \text{ C}^2/(\text{N m}^2)}{2} \left( 7.4 \times 10^4 \frac{\text{N}}{\text{C}} \right)^2 = 2.43 \times 10^{-2} \frac{\text{J}}{\text{m}^3},$$

and the magnetic field density  $u_B = B^2/2\mu_0$ ,

$$u_B = \frac{(0.52 \text{ T})^2}{2 \cdot 4\pi \cdot 10^{-7} \text{ T}/(\text{A m})} = 1.1 \times 10^5 \frac{\text{J}}{\text{m}^3}.$$

We calculate the ratio of the energy densities:  $\chi = u_E/u_B$ ,

$$\chi = \frac{2.43 \times 10^{-2} \text{ J/m}^3}{1.1 \times 10^5 \text{ J/m}^3} = 2.2 \times 10^{-7}.$$

Since  $E = v_p B$ , we find the ratio  $\chi = (\epsilon_0 v_p^2 B^2/2)/(B^2/2\mu_0)$ . Since  $\epsilon_0 \mu_0 = 1/c^2$ , where  $c$  is the speed of light, we find  $\chi = (v_p/c)^2$ ,

$$\chi = \left( \frac{1.45 \times 10^5 \text{ m/s}}{3.0 \times 10^8 \text{ m/s}} \right)^2 = 2.2 \times 10^{-7}.$$

**Problem 3.11:** We use the right-hand-rule to see that the particle is negatively charged. The speed for the first half-revolution follows  $v_1 = \pi r_1 / t_1 = \pi \cdot 4.2 \times 10^{-2} \text{ m} / (32 \times 10^{-6} \text{ s}) = 4.12 \times 10^3 \text{ m/s}$ . Since the magnetic force is equal to the centripetal force,  $mv_1^2 / r_1 = |q|v_1 B$ , we find  $|q| = mv_1 / r_1 B$ ,

$$|q| = \frac{83 \times 10^{-12} \text{ kg} \cdot 4.12 \times 10^3 \text{ m/s}}{0.042 \text{ m} \cdot 0.342 \text{ T}} = 23.8 \mu\text{C}.$$

We find the speed for the second half-revolution:  $v_2 = 0.8 v_1 = 0.8 \cdot 4.12 \times 10^3 \text{ m/s} = 3.30 \times 10^3 \text{ m/s}$ . We obtain the corresponding radius:  $r_2 = mv_2 / |q| B$ ,

$$r_2 = \frac{83 \times 10^{-12} \text{ kg} \cdot 3.30 \times 10^3 \text{ m/s}}{23.8 \times 10^{-6} \text{ C} \cdot 0.342 \text{ T}} = 0.033 \text{ m} = 3.3 \text{ cm}.$$

We find the time for the second half-revolution:  $t_2 = \pi r_2 / v_2$ ,

$$t_2 = \frac{\pi \cdot 0.033 \text{ m}}{3.3 \times 10^3 \text{ m/s}} = 32 \mu\text{s}.$$

Note that  $t_1 = t_2 = T/2$ : the period only depends on the charge and the magnetic field. It follows that the ratios of the radii and velocities are identical to each other:  $r_f / r_1 = v_f / v_1$ ,

$$\frac{r_f}{r_1} = \frac{0.2 \text{ cm}}{4.2 \text{ cm}} = 0.0476.$$

Since the speed decreases by a factor for each crossing of the lead piece, we the speed after  $n + 1$  crossings follows  $0.046 = (0.8)^n$ . We take the (natural) logarithm  $\ln 0.046 = n \cdot \ln 0.8$  and obtain the number of turns:

$$n = \frac{\ln 0.0476}{\ln 0.8} = 13.6,$$

we round up to find  $n = 14$ . We find the the wait time  $t_{\text{wait}} = 14 \cdot T/2$ ,

$$t_{\text{wait}} = 14 \cdot 32 \mu\text{s} = 448 \mu\text{s}.$$

**Problem 3.12:** The direction of the electric field is given by  $\tan \theta = E_y / E_x$

$$\tan \theta = \frac{-137 \text{ N/C}}{231 \text{ N/C}} = -0.59.$$

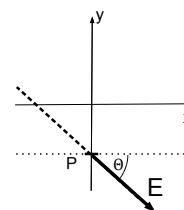

We find the location of the charge on the  $x$ -axis,  $x_q = 0.40 \text{ mm} / \tan \theta$

$$x_q = \frac{0.40 \text{ mm}}{(-0.59)} = -0.67 \text{ mm}.$$

The distance between the charge  $q$  and the point  $P$  follows:  $r = \sqrt{x_q^2 + y^2}$ ,

$$r = \sqrt{(-0.67 \text{ mm})^2 + (0.40 \text{ mm})^2} = 0.78 \text{ mm}.$$

The magnitude of the electric field is  $|\vec{E}| = \sqrt{E_x^2 + E_y^2}$

$$|\vec{E}| = \sqrt{\left(231 \frac{\text{N}}{\text{C}}\right)^2 + \left(-137 \frac{\text{N}}{\text{C}}\right)^2} = 268.6 \frac{\text{N}}{\text{C}}.$$

Since  $E = kq/r^2$ , we find the charge  $q = Er^2/k$ ,

$$q = \frac{268.8 \text{ N/C} \cdot (7.8 \times 10^{-4} \text{ m})^2}{8.99 \times 10^9 \text{ Nm}^2/\text{C}^2} = 1.8 \times 10^{-14} \text{ C}.$$

**Problem 3.13:** We simplify the circuit in four steps: (i)  $4 \Omega$  and  $8 \Omega$  in series:  $12 \Omega$ ; (ii)  $1 \Omega$  and  $5 \Omega$  in series:  $6 \Omega$ ; (iii)  $12 \Omega$  and  $6 \Omega$  in parallel:  $4 \Omega$ ; (iv)  $4 \Omega$  and  $3 \Omega$  in series:  $R_{\text{eq}} = 7 \Omega$ . We find the power  $P_{\text{batt}} = V^2/R_{\text{eq}}$ ,

$$P_{\text{batt}} = \frac{(12 \text{ V})^2}{7 \Omega} = 20.6 \text{ W}.$$

We obtain for the current through the battery:

$$I_{\text{batt}} = \frac{12 \text{ V}}{7 \Omega} = 1.7 \text{ A}.$$

We then find

$$12 \Omega \cdot I_1 = 6 \Omega \cdot I_2 \quad I_1 + I_2 = 1.7 \text{ A}.$$

Since  $I_2 = 2I_1$ , we find  $I_1 = 0.57 \text{ A}$  and  $I_2 = 1.14 \text{ A}$ . The dissipated power follows

$$P_{5\Omega} = 5 \Omega \cdot (1.14 \text{ A})^2 = 6.53 \text{ W}.$$

www.job.oticon.dk

oticon  
PEOPLE FIRST



**Problem 3.14:** The distance between the two wires is given by  $r = 0.068\text{ m}$ . The force per unit length between the wires is given by  $F/l = \mu_0 I^2 / (2\pi r)$ . We solve for the current  $I = \sqrt{(F/l) \cdot 2\pi r / \mu_0}$

$$I = \sqrt{\frac{1.2 \times 10^{-4} \text{ N/m} \cdot 2\pi \cdot 0.068 \text{ m}}{4\pi \times 10^{-7} \text{ Tm/A}}} = 6.4 \text{ A}.$$

The distance between the proton and the long thin wires:

$$R = \sqrt{(2.0 \text{ cm})^2 + (3.4 \text{ cm})^2} = 4.0 \text{ cm}.$$

The magnitude of the magnetic field at  $P$  produced by each wire is given by:  $B_1 = B_2 = \mu_0 I / (2\pi R)$ ,

$$B_1 = B_2 = 2.0 \times 10^{-7} \frac{\text{Tm}}{\text{A}} \frac{6.4 \text{ A}}{0.04 \text{ m}} = 3.2 \times 10^{-5} \text{ T}.$$

We introduce the direction  $\theta$  of the magnetic fields with the  $x$ -axis. We find  $\tan \theta = 3.4 \text{ cm} / 2.0 \text{ cm} = 1.7$  so that  $\theta = 59.5^\circ$ . The magnitude of the magnetic field follows  $B = |\vec{B}_1 + \vec{B}_2| = 2B \cos \theta$ ,

$$B = 2 \cdot 3.2 \times 10^{-5} \text{ T} \cdot \cos 59.5^\circ = 3.28 \times 10^{-5} \text{ T}.$$

The force on the proton is  $|\vec{F}| = evB$ :

$$|\vec{F}| = 1.6 \times 10^{-19} \text{ C} \cdot 341 \frac{\text{m}}{\text{s}} \cdot 3.28 \times 10^{-5} \text{ T} = 1.79 \times 10^{-21} \text{ N}.$$

We use the first RHR to find that the force is *out-of-the-page*.

**Problem 3.15:** We find the charge on the capacitor:  $Q_0 = CV$ ,

$$Q_0 = 3.2 \times 10^{-9} \text{ F} \cdot 24.0 \text{ V} = 7.7 \times 10^{-8} \text{ C}.$$

The angular frequency is given by  $\omega = 1/\sqrt{LC}$ ,

$$\omega = \frac{1}{\sqrt{3.2 \times 10^{-9} \text{ F} \cdot 1.3 \times 10^{-3} \text{ H}}} = 490 \text{ kHz}.$$

Since the period is  $T = 2\pi/\omega$ , we find the time  $t = T/4 = \pi/(2\omega)$ :

$$t = \frac{\pi}{2 \cdot 4.9 \times 10^5 \text{ s}^{-1}} = 3.2 \times 10^{-6} \text{ s} = 3.2 \mu\text{s}.$$

The charge on the capacitor corresponds to the coordinate so that the time dependence of the charge follows  $Q(t) = Q_{\max} \cos \omega t$  so that  $Q(t)/Q_{\max} = 1/3 = \cos \omega t$ . The time follows  $t = \omega^{-1} \cos^{-1}(1/3)$

$$t = \frac{1}{4.9 \times 10^5 \text{ s}^{-1}} \cdot \cos^{-1} \left( \frac{1}{3} \right) = 2.51 \times 10^{-6} \text{ s} = 2.51 \mu\text{s}.$$

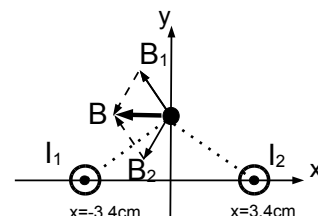

**Problem 3.16:** We find the radii  $r_1 = \sqrt{(2.5 \text{ cm})^2 + (3.5 \text{ cm})^2} = 4.3 \text{ cm}$  and  $r_2 = 3.5 \text{ cm}$ . Then the magnitudes of the magnetic fields at the point  $P$  produced by the currents  $I_i$  follows  $B_i = \mu_0 I_i / (2\pi r_i)$  follows:

$$B_1 = \frac{4\pi \cdot 10^{-7} \text{ Tm/A} \cdot 4.4 \text{ A}}{2\pi \cdot 4.3 \times 10^{-2} \text{ m}} = 20.5 \mu\text{T},$$

$$B_2 = \frac{4\pi \cdot 10^{-7} \text{ Tm/A} \cdot 3.3 \text{ A}}{2\pi \cdot 3.5 \times 10^{-2} \text{ m}} = 18.9 \mu\text{T}.$$

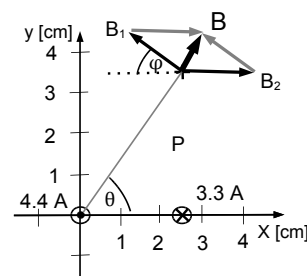

The angle  $\theta$  follows  $\tan \theta = (3.5 \text{ cm}) / (2.5 \text{ cm}) = 1.4$  so that  $\theta = 54.5^\circ$  and  $\phi = 90^\circ - 54.5^\circ = 35.5^\circ$ . We find the  $x$ -component of the magnetic field  $\vec{B}_1$ ,

$$B_{1,x} = -20.5 \mu\text{T} \cos 35.5^\circ = -16.7 \mu\text{T},$$

and the  $y$ -component

$$B_{1,y} = 20.5 \mu\text{T} \sin 35.5^\circ = 11.9 \mu\text{T}.$$

The  $y$ -component of the magnetic field  $\vec{B}_2$  is zero,  $B_{2y} = 0$ , and the  $x$ -component:

$$B_{2,x} = 18.9 \mu\text{T}.$$

We then find the net magnetic field  $\vec{B} = \vec{B}_1 + \vec{B}_2$ :

$$B_x = -16.7 \mu\text{T} + 18.9 \mu\text{T} = 2.2 \mu\text{T},$$

$$B_y = 11.9 \mu\text{T} + 0 = 11.9 \mu\text{T}.$$

We obtain magnitude of the magnetic field  $|\vec{B}| = \sqrt{B_x^2 + B_y^2}$ ,

$$|\vec{B}| = \sqrt{(2.2 \mu\text{T})^2 + (11.9 \mu\text{T})^2} = 12.1 \mu\text{T},$$

and the direction:  $\tan \theta_B = B_y / B_x$ ,

$$\tan \theta_B = \frac{11.9 \mu\text{T}}{2.2 \mu\text{T}} = 5.4,$$

so that the angle follows  $\theta_B = 79.5^\circ$ .

**Problem 3.17:** We find the capacitance  $C = \kappa \epsilon_0 A / d$ ,

$$C = 5.1 \frac{8.85 \times 10^{-12} \text{ C}^2/\text{N m}^2 \cdot 8.0 \times 10^{-4} \text{ m}^2}{4.0 \times 10^{-3} \text{ m}} = 9.0 \times 10^{-12} \text{ F}.$$

The voltage between the plates is  $V = Ed = 4.5 \times 10^3 \text{ V/m} \cdot 4.0 \times 10^{-3} \text{ m} = 18 \text{ V}$ . The charge on the capacitor plates follows  $Q = CV$ ,

$$Q = 9.0 \times 10^{-12} \text{ F} \cdot 18 \text{ V} = 1.62 \times 10^{-10} \text{ C}.$$

The electrostatic potential energy follows  $\text{EPE} = CV^2/2$ ,

$$\text{EPE} = \frac{1}{2} 9.0 \times 10^{-12} \text{ F} \cdot (18 \text{ V})^2 = 1.5 \times 10^{-9} \text{ J}.$$

**Problem 3.18:** We read-off the shortest distance between the point  $P$  and the wire:  $d = 2.0 \text{ cm} \cdot \sin 61^\circ = 1.75 \text{ cm}$ . We then find the magnitude of the magnetic field:  $B = \mu_0 I / (2\pi d)$ :

$$B = \frac{4\pi \times 10^{-7} \text{ Tm/A} \cdot 1.4 \text{ A}}{2\pi \cdot 0.0175 \text{ m}} = 16 \mu\text{T}.$$

The magnetic field is directed *into the page*!

We find magnitude of the force:  $F = qvB$

$$F = 8.3 \times 10^{-9} \text{ C} \cdot 352 \frac{\text{m}}{\text{s}} \cdot 16 \times 10^{-6} \text{ T} = 4.67 \times 10^{-11} \text{ N}.$$

We then obtain the acceleration:  $a = F/m$ ,

$$a = \frac{4.67 \times 10^{-11} \text{ N}}{3.8 \times 10^{-6} \text{ kg}} = 1.23 \times 10^{-5} \frac{\text{m}}{\text{s}^2}.$$

The force is directed along the  $-x$ -axis.

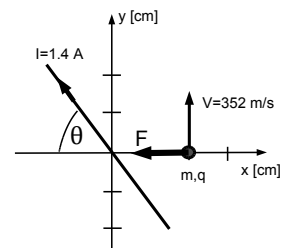
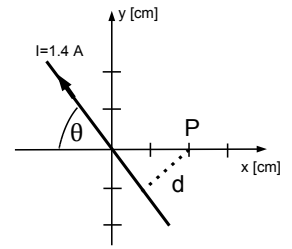

# INNOVATIVE LIKE YOU.

If you're hoping for a truly modern education, one where you're encouraged to speak your mind and to think long-term, both when it comes to your own future and the future of the planet. Then the University of Gothenburg is the place for you.

Study a Master's programme in Gothenburg, Sweden | [www.gu.se/education](http://www.gu.se/education)



Click on the ad to read more

**Problem 3.19:** The electron has potential energy due to the electrostatic potential produced by the He and Cl-ions:

$$\text{EPE} = k(-e) \left[ \frac{2e}{r_{\text{He}}} + \frac{-e}{r_{\text{Cl}}} \right] = 0,$$

so that  $2e/r_{\text{He}} = e/r_{\text{Cl}}$  or  $r_{\text{Cl}} = r_{\text{He}}/2$ . We write the distance between the two ions:  $5.0 \text{ cm} = r_{\text{He}} + r_{\text{Cl}}$  so that  $5.0 \text{ cm} = (3/2)r_{\text{He}}$ . We find  $r_{\text{He}} = 3.33 \text{ cm}$  and  $r_{\text{Cl}} = 1.67 \text{ cm}$ . We find the force on the electron:  $F = ke^2 \cdot [2/r_{\text{He}}^2 + 1/r_{\text{Cl}}^2]$ ,

$$F = 8.99 \times 10^9 \frac{\text{Nm}^2}{\text{C}^2} (1.602 \times 10^{-19} \text{ C})^2 \left[ \frac{2}{(0.033 \text{ m})^2} + \frac{1}{(0.017 \text{ m})^2} \right] = 1.22 \times 10^{-24} \text{ N}.$$

The force on the electron is towards the *left*. The electron moves towards the *left*:  $r'_{\text{He}} = 2.8 \text{ cm}$  and  $r_{\text{Cl}} = 2.2 \text{ cm}$  so that  $\text{EPE}' = k(-e) [2e/r'_{\text{He}} + (-e)/r_{\text{Cl}}]$ ,

$$\text{EPE}' = -8.99 \times 10^9 \frac{\text{Nm}^2}{\text{C}^2} (1.602 \times 10^{-19} \text{ C})^2 \left[ \frac{2}{0.028 \text{ m}} - \frac{1}{0.022 \text{ m}} \right] = -6.0 \times 10^{-27} \text{ J}.$$

We now use conservation of energy  $mv^2/2 = -\Delta\text{EPE}$  so that  $v = \sqrt{-2\Delta\text{EPE}/m}$ ,

$$v = \sqrt{-\frac{2 \cdot (-6.0 \times 10^{-27} \text{ J})}{9.11 \times 10^{-31} \text{ kg}}} = 115 \frac{\text{m}}{\text{s}}.$$

**Problem 3.20:** The spring force balances the weight of the particle:

$$\sum F_y = -mg + k\Delta l = 0.$$

We find the displacement of the spring:  $\Delta l = mg/k$ ,

$$\Delta l = \frac{4.8 \times 10^{-3} \text{ kg} \cdot 9.8 \text{ m/s}^2}{4.2 \text{ N/m}} = 1.1 \times 10^{-2} \text{ m} = 1.1 \text{ cm}.$$

Thus the unstretched length of the spring is  $l_0 = 7.3 \text{ cm} - 1.1 \text{ cm} = 6.2 \text{ cm}$ .

The forces are the spring force  $F_{\text{spring}}$ , the weight  $mg$ , and the Coulomb force  $F_C$ . The new stretch of the spring is  $l = \sqrt{(7.3 \text{ cm})^2 + (4.1 \text{ cm})^2} - 6.2 \text{ cm} = 2.2 \text{ cm}$ , and the spring force is  $F_{\text{spring}} = 4.2 \text{ N/m} \cdot 0.022 \text{ m} = 0.092 \text{ N}$ . The direction of the spring is  $\tan \theta = (7.3 \text{ cm})/(4.1 \text{ cm}) = 1.78$  so that  $\theta = 60.6^\circ$ . Newton's second law then follows:

$$\begin{aligned} \sum F_x &= 0.092 \text{ N} \cos 60.6^\circ + F_{C,x} = 0, \\ \sum F_y &= 0.092 \text{ N} \sin 60.6^\circ - 0.048 \text{ N} + F_{C,y} = 0. \end{aligned}$$

We thus find the  $x$ - and  $y$ -components of the Coulomb force:

$$F_{C,x} = -0.045 \text{ N}, \quad F_{C,y} = -0.032 \text{ N}.$$

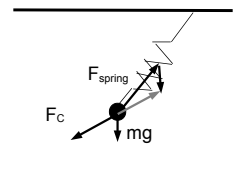

The magnitude of the Coulomb force follows:  $F_C = \sqrt{F_{C,x}^2 + F_{C,y}^2}$ ,

$$F_C = \sqrt{(-0.045 \text{ N})^2 + (-0.032 \text{ N})^2} = 0.055 \text{ N},$$

and direction  $\tan \phi = F_{C,y}/F_{C,x}$ ,

$$\tan \phi = \frac{-0.034 \text{ N}}{-0.045 \text{ N}} = 0.71,$$

so that the angle follows  $\phi = 35.4^\circ$ . Since  $\Delta Y = 12.5 \text{ cm} - 7.3 \text{ cm} = 5.2 \text{ cm}$ . We use  $\tan 35.4^\circ = \Delta Y/\Delta X$  to find

$$\Delta X = \frac{5.2 \text{ cm}}{\tan 35.4^\circ} = 7.32 \text{ cm}.$$

We find the distance between the charges  $d = 5.2 \times 10^{-2} \text{ m} / \sin 35.4^\circ = 9.0 \times 10^{-2} \text{ m}$ . Since the Coulomb force is given by  $F_C = kqQ/d^2$ , we solve for the unknown charge on the ground:  $Q = F_C d^2 / kq$ ,

$$Q = \frac{0.055 \text{ N} \cdot (0.09 \text{ m})^2}{8.99 \times 10^9 \text{ Nm}^2/\text{C}^2 \cdot 1.2 \times 10^{-6} \text{ C}} = 41 \text{ nC}.$$

**Problem 3.21:** We write down the junction rule:

$$I_1 + I_2 = I_3,$$

and the loop rules for #1 and #2:

$$\#1 \quad 8 - 2 = -3I_1 + 2I_2,$$

$$\#2 \quad -8 = -2I_2 - 4I_3 - 6I_3.$$

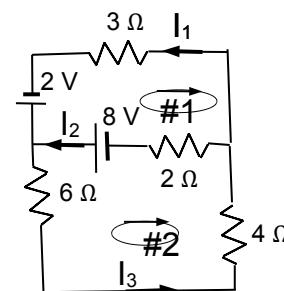

We insert  $I_3 = I_1 + I_2$  into the loop equations and find after some re-arrangements:

$$30 = -15I_1 + 10I_2,$$

$$12 = 15I_1 + 18I_2.$$

We get  $42 = 28I_2$  so that

$$I_2 = 1.5 \text{ A}.$$

We then obtain  $30 = -15I_1 + 10 \cdot 1.5$ , so that

$$I_1 = -1.0 \text{ A}.$$

The current  $I_3$  follows

$$I_3 = -1.0 \text{ A} + 1.5 \text{ A} = 0.5 \text{ A}.$$

We find the power delivered by the two batteries,  $P_{\text{batt}} = 2 \text{ V} \cdot I_1 + 8 \text{ V} \cdot I_2$ :

$$P = 2 \text{ V} \cdot (-1.0 \text{ A}) + 8 \text{ V} \cdot 1.5 \text{ A} = 10 \text{ W}.$$

Note that the power “delivered” by the 2-V battery is *negative*; this battery is “charged.”



**Problem 3.22:** We find the current through the rod:  $I_C = V_0/R = 12\text{ V}/63\ \Omega = 0.19\text{ A}$ . The current is in *clockwise* direction. Thus the acceleration of the rod is  $a = F_{\text{mag}}/m = I_C l B/m$ ,

$$a = \frac{0.19\text{ A} \cdot 0.13\text{ m} \cdot 3.4\text{ T}}{2.6 \times 10^{-3}\text{ kg}} = 32.3 \frac{\text{m}}{\text{s}^2}.$$

Use the RHR-1: the acceleration is towards the *right*. The induced EMF across the rod follows  $\mathcal{E}_{\text{ind}} = v_{\text{max}} l B$ ,

$$\mathcal{E}_{\text{ind}} = 17.8 \frac{\text{m}}{\text{s}} \cdot 0.13\text{ m} \cdot 3.4\text{ T} = 7.9\text{ V}.$$

Since  $\mathcal{E}_{\text{ind}} = V_{\text{min}}$ , the remaining charge is  $Q_{\text{min}} = CV_{\text{min}}$ ,

$$Q_{\text{min}} = 25.5 \times 10^{-3}\text{ F} \cdot 7.9\text{ V} = 0.20\text{ C}.$$

The initial charge on the capacitor is  $Q_{\text{max}} = CV_0$ ,

$$Q_{\text{max}} = 25.5 \times 10^{-3}\text{ F} \cdot 12\text{ V} = 0.31\text{ C}.$$

The electrostatic potential energy stored in the capacitor is given by  $\text{EPE} = CV^2/2$ . The change in the electrostatic potential energy:  $\Delta\text{EPE} = C[\mathcal{E}_{\text{in}}^2 - V_0^2]/2$ ,

$$\Delta\text{EPE} = \frac{25.5 \times 10^{-3}\text{ F}}{2} [(7.9\text{ V})^2 - (12\text{ V})^2] = -1.05\text{ J}.$$

We calculate the maximum kinetic energy of the rod,  $\text{KE} = mv_{\text{max}}^2/2$ ,

$$\text{KE} = \frac{2.6 \times 10^{-3}\text{ kg}}{2} \left(17.8 \frac{\text{m}}{\text{s}}\right)^2 = 0.41\text{ J}.$$

Without resistance of the track, the loss of electrostatic potential energy would be converted in the kinetic energy of the rod,  $\Delta\text{KE}_{\text{max}} = -\Delta\text{EPE} = 1.05\text{ J}$ . Thus, 40% of the electrostatic energy is converted into kinetic energy, and 60% is dissipated as heat in the resistor.

*Note:* The terminal speed of the rod can be calculated using calculus. One finds

$$v_{\text{max}} = \frac{V_0 l B}{m} \left(\frac{1}{C} + \frac{(lB)^2}{m}\right)^{-1}.$$

**Problem 3.23:** The forces are the weight  $mg = 2.0 \times 10^{-4}\text{ kg} \cdot 9.8\text{ m/s}^2 = 1.96 \times 10^{-3}\text{ N}$ , the tension in the silk  $T$  and the magnetic force  $F_B$ . Newton's second law yields:

$$\begin{aligned} \sum F_x &= -T \sin \theta - F_B = -m \frac{v^2}{r}, \\ \sum F_y &= T \cos \theta - mg = 0. \end{aligned}$$

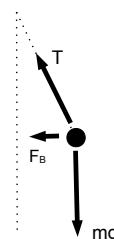

The tension in the string follows:  $T = mg/\cos \theta$ ,

$$T = \frac{1.96 \times 10^{-3}\text{ N}}{\cos 27^\circ} = 2.21 \times 10^{-3}\text{ N}.$$

The radius is given by  $r = 0.22 \text{ m} \sin 27^\circ = 0.10 \text{ m}$ . Then the speed is given by  $v = 2\pi r/\tau$ ,

$$v = \frac{2\pi \cdot 0.10 \text{ m}}{1.86 \text{ s}} = 0.337 \frac{\text{m}}{\text{s}}.$$

We find the magnetic force  $F_B = mv^2/r - T \sin \theta$ :

$$F_B = 2.0 \times 10^{-4} \text{ kg} \frac{(0.34 \text{ m/s})^2}{0.1 \text{ m}} - 2.2 \times 10^{-3} \text{ N} \sin 27^\circ = -7.73 \times 10^{-4} \text{ N}.$$

Since the magnetic force is given by  $F_B = QvB$ , the charge of the dust particle follows,  $|Q| = |F_B|/vB$

$$|Q| = \frac{7.73 \times 10^{-4} \text{ N}}{0.337 \text{ m/s} \cdot 25 \text{ T}} = 92 \mu\text{C}.$$

The dust particle is *negatively* charged.



 Sweden  
Sverige

Linköping University –  
innovative, highly ranked,  
European

Interested in Computer Science? Kick-start your career  
with an English-taught master's degree.

→ Click here!

**li.u** LINKÖPING  
UNIVERSITY



**Problem 3.24:** The average velocity of the phosphorous ion is  $v_{\text{ave}} = d/\Delta t$ ,

$$v_{\text{ave}} = \frac{3.7 \times 10^{-3} \text{ m}}{3.1 \times 10^{-7} \text{ s}} = 1.19 \times 10^4 \frac{\text{m}}{\text{s}}.$$

We express the average velocity in terms of the initial and final velocities,  $v_{\text{ave}} = (v_f + v_i)/2$  so that the final velocity is given by  $v_f = 2v_{\text{ave}} - v_i$ ,

$$v_f = 2 \cdot 1.19 \times 10^4 \frac{\text{m}}{\text{s}} - 1.82 \times 10^4 \frac{\text{m}}{\text{s}} = 5.7 \times 10^3 \frac{\text{m}}{\text{s}}.$$

The acceleration of the phosphorus ion follows  $a = (v_f - v_i)/\Delta t$ ,

$$a = \frac{5.7 \times 10^3 \text{ m/s} - 1.82 \times 10^4 \text{ m/s}}{3.1 \times 10^{-7} \text{ s}} = -4.0 \times 10^{10} \frac{\text{m}}{\text{s}^2}.$$

The magnitude of the force on the phosphorus ion follows  $F = ma$ ,

$$F = 31 \cdot 1.67 \times 10^{-27} \text{ kg} \cdot 4.0 \times 10^{10} \frac{\text{m}}{\text{s}^2} = 2.0 \times 10^{-15} \text{ N}.$$

The force points towards the *left*. We find the change in the kinetic energy of the phosphorus ion:  $\Delta \text{KE} = m(v_f^2 - v_i^2)/2$ ,

$$\Delta \text{KE} = \frac{31 \cdot 1.67 \times 10^{-27} \text{ kg}}{2} \left[ \left( 5.7 \times 10^3 \frac{\text{m}}{\text{s}} \right)^2 - \left( 1.28 \times 10^4 \frac{\text{m}}{\text{s}} \right)^2 \right] = -7.7 \times 10^{-18} \text{ J}.$$

Conservation of energy yields  $\Delta \text{KE} = -\Delta \text{EPE} = e\Delta V$ . We find the potential difference between the capacitor plates:  $\Delta V = \Delta \text{KE}/e$ ,

$$\Delta V = \frac{-7.7 \times 10^{-18} \text{ J}}{1.602 \times 10^{-19} \text{ C}} = -48.1 \text{ V}.$$

Thus, the potential difference  $V = 48.1 \text{ V}$  is applied to the capacitor. The charge on capacitor follows  $Q = CV$ ,

$$Q = 12.3 \times 10^{-12} \text{ F} \cdot 46.3 \text{ V} = 5.9 \times 10^{-10} \text{ C}.$$

The plate on the right is positively charged.

*Note:* Alternatively, the electric field inside the capacitor can be calculated from the force,  $E = F/e = 2.0 \times 10^{-15} \text{ N}/1.609 \times 10^{-19} \text{ C} = 12.4 \text{ kV/m}$  so that the potential difference follows  $|\Delta V| = Ed = (12.4 \text{ kV/m}) \cdot 3.7 \times 10^{-3} \text{ m} = 48.1 \text{ V}$ .

**Problem 3.25:** The electric fields  $\vec{E}_1$  and  $\vec{E}_2$  produced by  $Q_1$  and  $Q_2$ , respectively, and the total electric field  $\vec{E}_{\text{total}} = \vec{E}_1 + \vec{E}_2$ . We find the distance  $r_1 = 0.05 \text{ m}$  so that for the magnitude  $E_1 = kQ_1/r_1^2$ :

$$E_1 = \frac{8.99 \times 10^9 \text{ N m}^2/\text{C}^2 \cdot 4.0 \times 10^{-9} \text{ C}}{(0.05 \text{ m})^2} = 1.44 \times 10^4 \frac{\text{N}}{\text{C}},$$

and for the components

$$E_{1,x} = 0, \quad E_{1,y} = -1.44 \times 10^4 \frac{\text{N}}{\text{C}}.$$

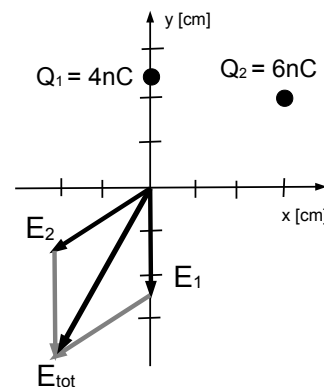

For  $r_2 = \sqrt{(0.06 \text{ m})^2 + (0.04 \text{ m})^2} = 0.072 \text{ m}$ . The electric field follows  $E_2 = kQ_2/r_2^2$ ,

$$E_2 = \frac{8.99 \times 10^9 \text{ N m}^2/\text{C}^2 \cdot 6.0 \times 10^{-9} \text{ C}}{(0.072 \text{ m})^2} = 1.04 \times 10^4 \frac{\text{N}}{\text{C}}.$$

We find the  $x$ - and  $y$ - components of  $\vec{E}_2$ :

$$E_{2,x} = -1.04 \times 10^4 \frac{\text{N}}{\text{C}} \cdot \frac{6.0 \text{ cm}}{7.2 \text{ cm}} = -8.7 \times 10^3 \frac{\text{N}}{\text{C}}$$

$$E_{2,y} = -1.04 \times 10^4 \frac{\text{N}}{\text{C}} \cdot \frac{4.0 \text{ cm}}{7.2 \text{ cm}} = -5.8 \times 10^3 \frac{\text{N}}{\text{C}}.$$

The  $x$ - and  $y$ -components of the total electric field follow:  $E_{\text{total},x} = E_{1,x} + E_{2,x}$  and  $E_{\text{total},y} = E_{1,y} + E_{2,y}$ , respectively,

$$E_{\text{total},x} = 0 - 8.7 \times 10^3 \frac{\text{N}}{\text{C}} = -8.7 \times 10^3 \frac{\text{N}}{\text{C}}$$

$$E_{\text{total},y} = -1.44 \times 10^4 \frac{\text{N}}{\text{C}} - 5.8 \times 10^3 \frac{\text{N}}{\text{C}} = -2.02 \times 10^4 \frac{\text{N}}{\text{C}}.$$

Thus, the magnitude of the total electric field follows:  $|\vec{E}_{\text{total}}| = \sqrt{E_{\text{total},x}^2 + E_{\text{total},y}^2}$ ,

$$|\vec{E}_{\text{total}}| = \sqrt{\left(-8.7 \times 10^3 \frac{\text{N}}{\text{C}}\right)^2 + \left(-2.02 \times 10^4 \frac{\text{N}}{\text{C}}\right)^2} = 2.2 \times 10^4 \frac{\text{N}}{\text{C}},$$

and for direction:  $\tan \theta = E_{\text{total},y}/E_{\text{total},x}$ ,

$$\tan \theta = \frac{-2.02 \times 10^4 \text{ N/C}}{-8.7 \times 10^3 \text{ N/C}} = 2.3,$$

so that  $\theta = 246^\circ$  with respect to the positive  $x$ -axis. We find  $\vec{E}_0 = -(\vec{E}_1 + \vec{E}_2) = -\vec{E}_{\text{total}}$  so that  $|\vec{E}_0| = |\vec{E}_{\text{total}}| = kQ_0/r_0^2$ , or  $r_0 = \sqrt{k|Q_0|/|\vec{E}_{\text{total}}|}$

$$r_0 = \sqrt{\frac{8.99 \times 10^9 \text{ N m}^2/\text{C}^2 \cdot 2.1 \times 10^{-9} \text{ C}}{2.2 \times 10^4 \text{ N/C}}} = 2.8 \text{ cm}.$$

We find the coordinates of the charge  $Q_0$ .

$$x_0 = 2.8 \text{ cm} \cos 66.5^\circ = 1.1 \text{ cm}, \quad y_0 = 2.8 \text{ cm} \sin 66.5^\circ = 2.56 \text{ cm}.$$

**Problem 3.26:** The forces are the weight  $mg = 0.054 \text{ N}$ , the tension in the string  $T$ , and the Coulomb force  $F_c$ . We find

$$\begin{aligned}\sum F_x &= F_c \cos \theta_1 - T \sin \theta_2 = 0 \\ \sum F_y &= F_c \sin \theta_1 + T \cos \theta_2 - 0.054 \text{ N} = 0\end{aligned}$$

We find the angles  $\cos \theta_2 = 10 \text{ cm}/13 \text{ cm}$  so that  $\theta_2 = 39.7^\circ$ . For the horizontal displacement of the first ball, we get  $\Delta x = 13 \text{ cm} \cdot \sin 39.7^\circ = 8.3 \text{ cm}$ . We then obtain  $\tan \theta_1 = 3.0 \text{ cm}/8.3 \text{ cm}$  so that  $\theta_1 = 19.85^\circ$ . We observe that  $\theta_2 = 2\theta_1$  (this is an exact result!). We get  $F_c = T \sin 39.7^\circ / \cos 19.85^\circ = 0.68 T$ . Thus

$$T [0.68 \sin 19.85^\circ + \cos 39.7^\circ] = T = 0.054 \text{ N}.$$

We get  $F_c = 0.68 \cdot 0.054 \text{ N} = 0.0367 \text{ N}$ . The distance  $d$  between the two balls follows from  $d \sin 19.85^\circ = 3.0 \text{ cm}$  so that

$$d = \frac{3.0 \text{ cm}}{\sin 19.85^\circ} = 8.83 \text{ cm}.$$

We get  $F_c = kQq/d^2$ , so that for the charge  $q = F_c d^2 / kQ$ ,

$$q = \frac{0.0367 \text{ N} \cdot (0.0883 \text{ m})^2}{8.99 \times 10^9 \text{ N m}^2/\text{C}^2 \cdot 85 \times 10^{-9} \text{ C}} = 374 \text{ nC}.$$

The change of the potential energy has two contributions: (1) lifting the first ball:  $\Delta \text{PE}_{\text{gravity}} = mgh$ , or

$$\Delta \text{PE}_{\text{gravity}} = 0.054 \text{ N} \cdot 0.03 \text{ m} = 1.62 \text{ mJ},$$

and the electrostatic potential energy:  $\Delta \text{PE}_{\text{electric}} = kQq/d$ , or

$$\Delta \text{PE}_{\text{electric}} = \frac{8.99 \times 10^9 \text{ N m}^2/\text{C}^2 \cdot 85 \times 10^{-9} \text{ C} \cdot 374 \times 10^{-9} \text{ C}}{0.0883 \text{ m}} = 3.24 \text{ mJ}.$$

We calculate the work from the changes in the gravitational and electrostatic potential energies,  $W = \Delta \text{PE}_{\text{gravity}} + \Delta \text{PE}_{\text{electric}}$ , or

$$W = 1.62 \text{ mJ} + 3.07 \text{ mJ} = 4.7 \text{ mJ}.$$

*Note:* The change in the electrostatic potential energy is twice the change in the gravitational potential energy  $\Delta \text{PE}_{\text{electric}} = 2\Delta \text{PE}_{\text{gravity}}$ . This is an exact result, and is left for the reader to derive.

**Problem 3.27:** The distance between the current wire and the point  $P$  is  $r = \sqrt{(1.0 \text{ cm})^2 + (2.0 \text{ cm})^2} = 2.24 \text{ cm}$ .

We find the magnitude of the magnetic field:  $B = \mu_0 I / 2\pi r$ ,

$$B = \frac{4\pi \times 10^{-7} \text{ Tm/A} \cdot 2.3 \text{ A}}{2\pi \cdot 2.24 \times 10^{-2} \text{ m}} = 2.06 \times 10^{-5} \text{ T}.$$

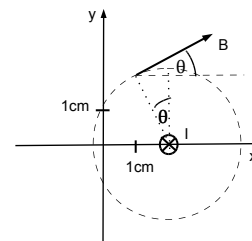
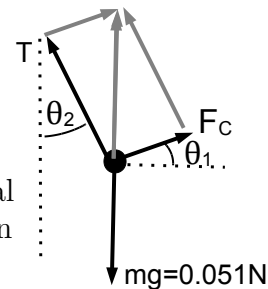

The angle follows  $\tan \theta = (1.0 \text{ cm}) / (2.0 \text{ cm}) = 26.5^\circ$ . The  $x$ - and  $y$ -components of the magnetic field follow

$$B_x = 2.06 \times 10^{-5} \text{ T} \cos 26.5^\circ = 1.84 \times 10^{-7} \text{ T}$$

$$B_y = 2.06 \times 10^{-5} \text{ T} \sin 26.5^\circ = 0.92 \times 10^{-7} \text{ T}.$$

The angle is given by  $\theta' = 90^\circ - 26.5^\circ = 63.5^\circ$  between the magnetic field  $\vec{B}$  and the velocity  $\vec{v}$ . Thus for the magnetic force:  $F = |q|vB \sin \theta'$ , or

$$F = 3.7 \times 10^{-12} \text{ C} \cdot 1291 \frac{\text{m}}{\text{s}} \cdot 2.06 \times 10^{-5} \text{ T} \sin 63.5^\circ = 8.81 \times 10^{-14} \text{ N}.$$

Alternatively,  $|F| = |q|v|B_x| = 3.7 \times 10^{-12} \text{ C} \cdot 1291 \text{ m/s} \cdot 1.84 \times 10^{-7} \text{ T} = 8.81 \times 10^{-14} \text{ N}$ . Because  $q < 0$ , the force is directed along the  $+z$ -axis [*out-of-the-page*]. The magnitude of the acceleration of the dust particle follows  $|a| = |\vec{F}|/m$ :

$$|a| = \frac{8.81 \times 10^{-14} \text{ N}}{4.7 \times 10^{-8} \text{ kg}} = 1.87 \times 10^{-6} \frac{\text{m}}{\text{s}^2}.$$

In the same direction as the force; i.e., *out-of-the-page*.

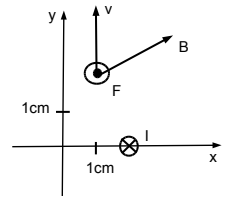

**STUDY FOR YOUR MASTER'S DEGREE  
IN THE CRADLE OF SWEDISH ENGINEERING**

Chalmers University of Technology conducts research and education in engineering and natural sciences, architecture, technology-related mathematical sciences and nautical sciences. Behind all that Chalmers accomplishes, the aim persists for contributing to a sustainable future – both nationally and globally.

Visit us on **Chalmers.se** or **Next Stop Chalmers** on facebook.

**CHALMERS**  
UNIVERSITY OF TECHNOLOGY



Click on the ad to read more

**Problem 3.28:** We find the radii  $r_{1A} = 0.06$  m,  $r_{2A} = 0.03$  cm;  $r_{1B} = 0.04$  m,  $r_{2B} = 0.01$  m; and  $r_{1C} = 0.04$  m,  $r_{2C} = \sqrt{(0.03 \text{ m})^2 + (0.04 \text{ m})^2} = 0.05$  m. Since  $r_{1B} = r_{1C}$ , the work  $W_{BC}$  is stored as electrostatic potential energy:  $W_{BC} = e\Delta V_{CB}$ ,

$$W_{BC} = keq_1 \left[ \frac{1}{r_{1C}} - \frac{1}{r_{1B}} \right] + keq_2 \left[ \frac{1}{r_{2C}} - \frac{1}{r_{2B}} \right] = ekq_2 \left[ \frac{1}{r_{2C}} - \frac{1}{r_{2B}} \right].$$

We insert  $W_{BC}$  and solve for the unknown charge  $q_2 = (W_{BC}/ek) \cdot [1/r_{2C} - 1/r_{2B}]^{-1}$ ,

$$q_2 = \frac{367 \text{ V}}{8.99 \times 10^9 \text{ N m}^2/\text{C}^2} \left[ \frac{1}{0.05 \text{ m}} - \frac{1}{0.01 \text{ m}} \right]^{-1} = -0.51 \text{ nC}.$$

We find the work  $W_{AB} = ekq_1 [1/r_{1B} - 1/r_{1A}] + ekq_2 [1/r_{2B} - 1/r_{2A}]$ . We find  $ekq_2 [1/r_{2B} - 1/r_{2A}] = 8.99 \times 10^9 \text{ N m}^2/\text{C}^2 \cdot (-0.51 \times 10^{-9} \text{ C}) \cdot [1/0.01 \text{ m} - 1/0.03 \text{ m}] = -305.7 \text{ V}$ . Since  $W_{AB} = 343 \text{ eV}$ , we find

$$8.99 \times 10^9 \frac{\text{N m}^2}{\text{C}^2} q_1 \left[ \frac{1}{0.04 \text{ m}} - \frac{1}{0.06 \text{ m}} \right] = 343 \text{ V} - (-305.7 \text{ V}) = 648.7 \text{ V}.$$

We thus obtain the charge  $q_1$ :

$$q_1 = \frac{648.7 \text{ V}}{8.99 \times 10^9 \text{ N m}^2/\text{C}^2 \cdot 20.0 \text{ m}^{-1}} = 3.6 \text{ nC}.$$

We find the electrostatic potential energy of the potassium ion at the point  $C$ :

$$\begin{aligned} \text{EPE} &= 8.99 \times 10^9 \frac{\text{N m}^2}{\text{C}^2} \cdot 1.602 \times 10^{-19} \text{ C} \left[ \frac{4.3 \times 10^{-9} \text{ C}}{0.04 \text{ m}} + \frac{(-0.51 \times 10^{-9} \text{ C})}{0.05 \text{ m}} \right] \\ &= 1.4 \times 10^{-16} \text{ J}. \end{aligned}$$

The initial electrostatic potential energy is transformed into kinetic energy of the potassium ion. Since  $m = 39 \cdot 1.67 \times 10^{-27} \text{ kg} = 6.5 \times 10^{-26} \text{ kg}$ , we find  $\text{EPE} = mv^2/2$ , or  $v = \sqrt{2 \text{EPE}/m}$

$$v = \sqrt{\frac{2 \cdot 1.4 \times 10^{-16} \text{ J}}{6.5 \times 10^{-26} \text{ kg}}} = 6.5 \times 10^4 \frac{\text{m}}{\text{s}}.$$

**Problem 3.29:** We find the capacitance of the empty parallel capacitor:  $C_0 = \epsilon_0 A/d$ ,

$$C_0 = 8.85 \times 10^{-12} \frac{\text{C}^2}{\text{N m}^2} \frac{3.3 \times 10^{-4} \text{ m}^2}{2.7 \times 10^{-3} \text{ m}} = 1.1 \times 10^{-12} \text{ F} = 1.1 \text{ pF}.$$

and filled with dielectric material:  $C = \kappa C_0 = 7.3 \cdot 1.1 \text{ nF} = 7.9 \text{ pF}$ . We find the charge:  $Q = CV$

$$Q = 8.0 \times 10^{-12} \text{ F} \cdot 12 \text{ V} = 9.6 \times 10^{-11} \text{ C}.$$

The charge on the battery remains fixed when the battery is removed:  $Q_0 = Q$ . We find the potential difference  $V_0 = Q/C_0 = Q/(C/\kappa)$  so that  $V_0 = \kappa(Q/C) = \kappa V$ ,

$$V_0 = 7.3 \cdot 12.0 \text{ V} = 87.6 \text{ V}.$$

Alternatively,  $V_0 = 9.6 \times 10^{-11} \text{C} / 1.1 \times 10^{-12} \text{F} = 87.6 \text{V}$ . Since the slab is removed very slowly, the total work done on the slab is zero:  $W_{\text{total}} = W_{\text{ext}} + W_E = 0$ . We thus find  $W_{\text{ext}} = \Delta \text{EPE} = Q^2 / 2C_0 - Q^2 / 2C$ , or

$$W_{\text{ext}} = \frac{(9.6 \times 10^{-11} \text{C})^2}{2} \left[ \frac{1}{1.1 \times 10^{-12} \text{F}} - \frac{1}{8.0 \times 10^{-12} \text{F}} \right] = 3.6 \times 10^{-9} \text{J}.$$

That is, *you* need to do work!

The electrostatic potential energy is *lower* when the slab is fully inserted compared to when the slab is removed. This shows that the electric force on the slab is pointing towards the inside of the capacitor. We find force,  $|F_E| = \Delta \text{EPE} / d$ ,

$$|F_E| = \frac{3.6 \times 10^{-9} \text{J}}{1.8 \times 10^{-2} \text{m}} = 2.0 \times 10^{-7} \text{N} = 200 \text{nN}.$$

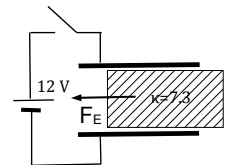



**MÄLARDALEN UNIVERSITY**  
SWEDEN

**WELCOME TO  
OUR WORLD  
OF TEACHING!**

INNOVATION, FLAT HIERARCHIES  
AND OPEN-MINDED PROFESSORS

**STUDY IN SWEDEN -  
CLOSE COLLABORATION  
WITH FUTURE EMPLOYERS**

MÄLARDALEN UNIVERSITY COLLABORATES WITH  
MANY EMPLOYERS SUCH AS ABB, VOLVO AND  
ERICSSON

TAKE THE  
RIGHT TRACK

GIVE YOUR CAREER A HEADSTART AT MÄLARDALEN UNIVERSITY

[www.mdh.se](http://www.mdh.se)

**DEBAJYOTI NAG**  
SWEDEN, AND PARTICULARLY  
MDH, HAS A VERY IMPRES-  
SIVE REPUTATION IN THE FIELD  
OF EMBEDDED SYSTEMS RE-  
SEARCH, AND THE COURSE  
DESIGN IS VERY CLOSE TO THE  
INDUSTRY REQUIREMENTS.

HE'LL TELL YOU ALL ABOUT IT AND  
ANSWER YOUR QUESTIONS AT  
[MDUSTUDENT.COM](http://MDUSTUDENT.COM)

192



Click on the ad to read more



**Problem 3.30:** For uniform circular motion, the speed is given by  $v = 2\pi r/T$  so that the period follows  $T = 2\pi r/v$ ,

$$T = \frac{2\pi \cdot 5.3 \times 10^{-11} \text{ m}}{2.2 \times 10^6 \text{ m/s}} = 1.51 \times 10^{-16} \text{ s.}$$

We find the current corresponding to the orbiting proton:  $I = e/T$ ,

$$I_{\text{eff}} = \frac{1.6 \times 10^{-19} \text{ C}}{1.51 \times 10^{-16} \text{ s}} = 1.1 \times 10^{-3} \text{ A.}$$

The magnetic field of a current loop is given by  $B = \mu_0 I/2r$ ,

$$B = \frac{4\pi \cdot 10^{-7} \text{ Tm/A} \cdot 1.1 \times 10^{-3} \text{ A}}{2 \cdot 5.3 \times 10^{-11} \text{ m}} = 13.1 \text{ T.}$$

The magnetic field is directed *into* the page. The angular momentum is given by  $L = (mv)r$ ,

$$L = 1.67 \times 10^{-27} \text{ kg} \cdot 2.2 \times 10^6 \frac{\text{m}}{\text{s}} \cdot 5.3 \times 10^{-11} \text{ m} = 1.95 \times 10^{-31} \text{ J s.}$$

This gives the ratio  $\chi = B/L$

$$\chi = \frac{13.1 \text{ T}}{1.94 \times 10^{-31} \text{ J s}} = 6.7 \times 10^{31} \frac{1}{\text{Cm}^2}.$$

*Note:* We find the current  $I = e \cdot v/2\pi r$  so that for the magnetic field at the center can be written:  $B = \mu_0 e \cdot (v/2\pi r)/2r = (\mu_0 ev)/(4\pi r^2)$ . The ratio  $\chi$  can be written  $\chi = (\mu_0 ev/4\pi r^2) \cdot (1/mvr)$ ,  $\chi = (\mu_0 e)/(4\pi mr^3)$ . That is, the spin of the electron “sees” a magnetic field produced by the proton that is proportional to the proton’s angular momentum: we say that the electron spin is coupled to the angular momentum. This *spin-orbit* coupling gives rise to the *fine structure* of spectral lines.

**Problem 3.31:** At the origin:  $d_O = 9.42 \times 10^{-11} \text{ m} \cdot \cos 53^\circ = 5.57 \times 10^{-11} \text{ m}$  and  $d_H = 9.42 \times 10^{-11} \text{ m} \cdot \sin 53^\circ = 7.52 \times 10^{-11} \text{ m}$ . Then

$$\begin{aligned} \text{EPE}_O &= 8.99 \times 10^9 \frac{\text{N m}^2}{\text{C}^2} \cdot (-1.602 \times 10^{-19} \text{ C}) \left[ \frac{(-0.67 \cdot 1.602 \times 10^{-19} \text{ C})}{5.57 \times 10^{-11} \text{ m}} \right. \\ &\quad \left. + 2 \frac{0.335 \cdot 1.602 \times 10^{-19} \text{ C}}{7.52 \times 10^{-11} \text{ m}} \right] = 7.27 \times 10^{-19} \text{ J} = 4.52 \text{ eV.} \end{aligned}$$

Thus we obtain the distance between the oxygen and  $P$ :  $r_O = 1.1 \times 10^{-10} \text{ m} + 0.57 \times 10^{-10} \text{ m} = 1.67 \times 10^{-10} \text{ m}$ . We calculate the distance between a hydrogen atom and the point  $P$ :

$$r_H = \sqrt{(9.42 \times 10^{-11} \text{ m} \cdot \sin 53^\circ)^2 + (1.1 \times 10^{-10} \text{ m})^2} = 1.33 \times 10^{-10} \text{ m.}$$

The electrostatic potential energy follows

$$\begin{aligned} \text{EPE}_P &= 8.99 \times 10^9 \frac{\text{N m}^2}{\text{C}^2} \cdot (-1.602 \times 10^{-19} \text{ C}) \left[ \frac{(-0.67 \cdot 1.602 \times 10^{-19} \text{ C})}{1.67 \times 10^{-10} \text{ m}} \right. \\ &\quad \left. + 2 \frac{0.335 \cdot 1.602 \times 10^{-19} \text{ C}}{1.33 \times 10^{-10} \text{ m}} \right] = -2.38 \times 10^{-19} \text{ J} = -1.48 \text{ eV.} \end{aligned}$$

1. We find the change in electrostatic potential energy  $EPE_P = -1.48 \text{ eV}$ , the potential energy *decreases* as the electron gets closer to the origin.
2. The EPE reaches a minimum  $EPE_{\min} < 0$ .
3. The potential energy then increases as the electron approaches the origin, and finally  $EPE_0 = 4.5 \text{ eV}$ .

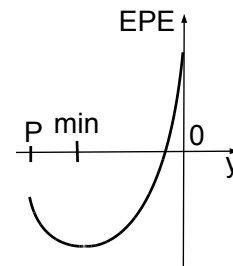

We find  $\Delta EPE = 4.52 \text{ eV} - (-1.48 \text{ eV}) = 6.0 \text{ eV}$  so that  $KE_P = 9.65 \times 10^{-19} \text{ J} \doteq mv_P^2/2$ . Thus the speed of the electron at the point  $P$  follows

$$v_P = \sqrt{\frac{2 \cdot 9.65 \times 10^{-19} \text{ J}}{9.11 \times 10^{-31} \text{ kg}}} = 1.46 \times 10^6 \frac{\text{m}}{\text{s}}.$$

**Problem 3.32:** In the presence of an electric field along the  $+y$ -direction, the potassium ion undergoes projectile motion. We find the time to reach  $P$  from the horizontal displacement: Since  $v_x = v_{x,0} = \text{const}$  so that  $x_p = v_{x,0}t^*$  and  $t^* = x_p/v_{x,0}$

$$t^* = \frac{0.015 \text{ m}}{5413 \text{ m/s}} = 2.77 \mu\text{s}.$$

We find the vertical component of the velocity at  $P$ :  $v_y = v_x \tan 22^\circ$  so that

$$v_y = 5413 \frac{\text{m}}{\text{s}} \cdot \tan 22^\circ = 2,187 \frac{\text{m}}{\text{s}}.$$

Since  $v_{y,0} = 0$ , we obtain  $v_y = at^*$  and find the acceleration  $a_y = v_y/t^*$ ,

$$a_y = \frac{2817 \text{ m/s}}{2.77 \mu\text{s}} = 7.90 \times 10^8 \frac{\text{m}}{\text{s}^2}.$$

We then find coordinate  $y_p = a_y(t^*)^2/2$ ,

$$y_p = \frac{1}{2} 7.90 \times 10^8 \frac{\text{m}}{\text{s}^2} \cdot (2.77 \times 10^{-6} \text{ s})^2 = 3.0 \text{ mm}.$$

The force on the potassium ion follows  $F = ma = 39 \cdot 1.67 \times 10^{-27} \text{ kg} \cdot 7.9 \times 10^8 \text{ m/s}^2 = 5.14 \times 10^{-17} \text{ N}$ . We find the magnitude of the electric field  $E = F/e$ ,

$$E = \frac{5.14 \times 10^{-17} \text{ N}}{1.6 \times 10^{-19} \text{ C}} = 321 \frac{\text{N}}{\text{C}}.$$

The trajectory of the potassium ion follows a circle when a magnetic field is present. Since  $x_p = R \sin \theta$ , we obtain

$$R = \frac{0.015 \text{ m}}{\sin 22^\circ} = 0.040 \text{ m}.$$

Thus the center of the circle is  $Y_c = 4.0 \text{ cm}$ . We then obtain the vertical deflection  $y_p = Y_c - R \cos \theta$

$$y_p = 4.0 \cdot (1 - \cos 22^\circ) = 2.9 \text{ mm}$$

The  $\text{K}^+$  ion travels at constant speed. Since  $\theta = 0.384 \text{ rad}$  and  $s = R\theta = 0.04 \text{ m} \cdot 0.384 = 1.54 \text{ cm}$ , we find for the time  $t^*$ :

$$t^* = \frac{0.0154 \text{ m}}{5413 \text{ m/s}} = 2.84 \mu\text{s}.$$

We find the period of the uniform circular motion,  $T = 2\pi R/v$

$$T = \frac{2\pi \cdot 0.04 \text{ m}}{5413 \text{ m/s}} = 46.4 \mu\text{s}.$$

We obtain  $mv^2/R = evB$  so that  $v/R = 2\pi/T = eB/m$ . We solve for the magnetic field,  $B = 2\pi m/eT$

$$B = \frac{2\pi \cdot 39 \cdot 1.67 \times 10^{-27} \text{ kg}}{1.602 \times 10^{-19} \text{ C} \cdot 46.4 \times 10^{-6} \text{ s}} = 55.1 \text{ mT}.$$

*Note:* We calculate the ratio  $E/B = (321 \text{ N/C})/(55.1 \text{ mT}) = 5836 \text{ m/s} \simeq v_0$ .

**Problem 3.33:** The weight of the oil drop is equal to the electric force:  $mg = |qE|$  or

$$|\vec{E}| = \frac{1.2 \times 10^{-15} \text{ kg} \cdot 9.8 \text{ m/s}^2}{1.6 \times 10^{-19} \text{ C}} = 7.4 \times 10^4 \frac{\text{N}}{\text{C}}.$$

The electric force is pointed *upwards* - the electric field points *downwards*. We find the electrostatic potential  $W = Ed$ , or

$$V = 7.4 \times 10^4 \frac{\text{N}}{\text{C}} \cdot 2.5 \times 10^{-2} \text{ m} = 1.8 \text{ kV}.$$

The electric field points from the higher to the lower potential. The *upper* plate is at the higher potential. The capacitance  $C = \epsilon_0 A/d$  follows

$$C = \frac{8.85 \times 10^{-12} \text{ C}^2/(\text{N} \cdot \text{m}^2) \cdot 5.5 \times 10^{-4} \text{ m}^2}{2.5 \times 10^{-2} \text{ m}} = 1.95 \times 10^{-13} \text{ F} = 0.195 \text{ pF}.$$

The charge on the capacitor is then given by  $Q = CV$ ,

$$Q = 1.95 \times 10^{-13} \text{ F} \cdot 1.8 \text{ kV} = 3.5 \times 10^{-10} \text{ C} = 0.35 \text{ nC}.$$

**Problem 3.34:** We find the charge on the capacitor:  $Q_0 = CV_0 = 8.0 \mu\text{F} \cdot 12.0 \text{ V} = 96.0 \mu\text{C}$ , and the electrostatic energy stored in the capacitor:  $\text{EPE} = V_0 Q/2$  so that

$$\text{EPE} = \frac{1}{2} 12.0 \text{ V} \cdot 96.0 \mu\text{C} = 576 \mu\text{J}.$$

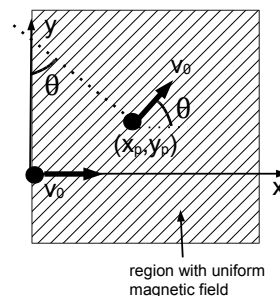

We find the time constant  $\tau = RC$ , or

$$\tau = 6.0 \times 10^6 \Omega \cdot 8.0 \times 10^{-6} \text{ F} = 48.0 \text{ s}.$$

The charge stored in the capacitor decays exponentially with time,  $Q = Q_0 \exp(-t/\tau)$ . We obtain the charge on the capacitor at the time  $t = 2.0 \text{ s}$ :

$$Q = 96.0 \mu\text{C} \cdot \exp\left(-\frac{2.0 \text{ s}}{48.0 \text{ s}}\right) = 92.1 \mu\text{C}.$$

The average current can be calculated from the flow of charge:  $I_{\text{ave}} = |\Delta Q/\Delta t|$ ,

$$I_{\text{ave}} = \left| \frac{92.1 \mu\text{C} - 96.0 \mu\text{C}}{2.0 \text{ s}} \right| = 2.0 \mu\text{A}.$$

The voltage across the capacitor is given by  $V = Q/C$ , or

$$V = \frac{92.1 \mu\text{C}}{8.0 \mu\text{F}} = 11.5 \text{ V}.$$

Thus, the electrostatic energy stored in the capacitor at time  $t = 2.0 \text{ s}$ :  $E_{\text{tot}} = QV'/2$

$$E'_{\text{tot}} = \frac{1}{2} 92.1 \mu\text{C} \cdot (11.5 \text{ V})^2 = 529.6 \mu\text{J}.$$

The change in the electrostatic potential energy is dissipated as heat in the resistor:  $E_{\text{diss}} = E_{\text{tot}} - E'_{\text{tot}}$ ,

$$E_{\text{diss}} = 576 \mu\text{J} - 529.6 \mu\text{J} = 46.4 \mu\text{J}.$$

*Alternatively*, the energy dissipated in the resistor follows  $E_{\text{diss}} \simeq I_{\text{ave}} V \Delta t$ ,

$$E_{\text{diss}} \simeq 2.0 \mu\text{A} \cdot 12.0 \text{ V} \cdot 2.0 \text{ s} = 48 \mu\text{J},$$

as it should! Note that the numbers are not exactly the same because of some approximations made in the second method.

**Problem 3.35:** The electrostatic potential at the origin due to the sodium ion is given by  $V_{\text{Na}} = ke/|x_{\text{Na}}|$ ,

$$V_{\text{Na}} = \frac{8.99 \times 10^9 \text{ N m}^2/\text{C}^2 \cdot 1.602 \times 10^{-19} \text{ C}}{1.0 \times 10^{-8} \text{ m}} = 145.0 \text{ mV},$$

and the electrostatic potential at the origin due to the potassium ion:  $V_{\text{K}} = -ke/|x_{\text{K}}|$ ,

$$V_{\text{K}} = \frac{8.99 \times 10^9 \text{ N m}^2/\text{C}^2 \cdot 1.602 \times 10^{-19} \text{ C}}{2.5 \times 10^{-8} \text{ m}} = -58.0 \text{ mV}$$

Thus the total potential at the origin is given by the sum:  $V = V_{\text{Na}} + V_{\text{K}}$

$$V = 145.0 \text{ mV} + (-58.0 \text{ mV}) = 87.0 \text{ mV}$$

The potential energy of the electron follows  $\text{EPE} = (-e)V$ ,

$$\text{EPE} = -87.0 \text{ meV} = -1.40 \times 10^{-20} \text{ J},$$

and the kinetic energy  $KE = mv^2/2$ ,

$$KE = \frac{9.11 \times 10^{-31} \text{ kg}}{2} \left( 2.1 \times 10^5 \frac{\text{m}}{\text{s}} \right)^2 = 2.0 \times 10^{-20} \text{ J} = 124.8 \text{ meV}.$$

Thus the total energy of electron is  $E = KE + EPE$ , or

$$E = 124.8 \text{ meV} + (-87.0 \text{ meV}) = 37.8 \text{ meV} = 6.1 \times 10^{-21} \text{ J}.$$

The electrostatic potential at  $x = -2.5 \text{ nm}$  is given by  $V_P = ke(1/|x_{Na} - x| - 1/|x_K - x|)$ , or

$$V_P = 8.99 \times 10^9 \frac{\text{N m}^2}{\text{C}^2} \cdot 1.602 \times 10^{-19} \text{ C} \left( \frac{1}{12.5 \text{ nm}} - \frac{1}{22.5 \text{ nm}} \right) = 51.2 \text{ mV}.$$

The electrostatic potential energy of the electron at  $x$  is  $EPE' = -51.5 \text{ meV} = -8.3 \times 10^{-21} \text{ J}$ .  
The kinetic energy of the electron is  $KE' = E - EPE'$  so that

$$KE' = 38.1 \text{ meV} - (-51.5 \text{ meV}) = 89.6 \text{ meV} = 1.44 \times 10^{-20} \text{ J}.$$

The speed of the electron follows  $v' = \sqrt{2KE'/m}$

$$v' = \sqrt{\frac{2 \cdot 1.44 \times 10^{-20} \text{ J}}{9.11 \times 10^{-31} \text{ kg}}} = 1.8 \times 10^5 \frac{\text{m}}{\text{s}}.$$



## Develop the tools we need for Life Science Masters Degree in Bioinformatics

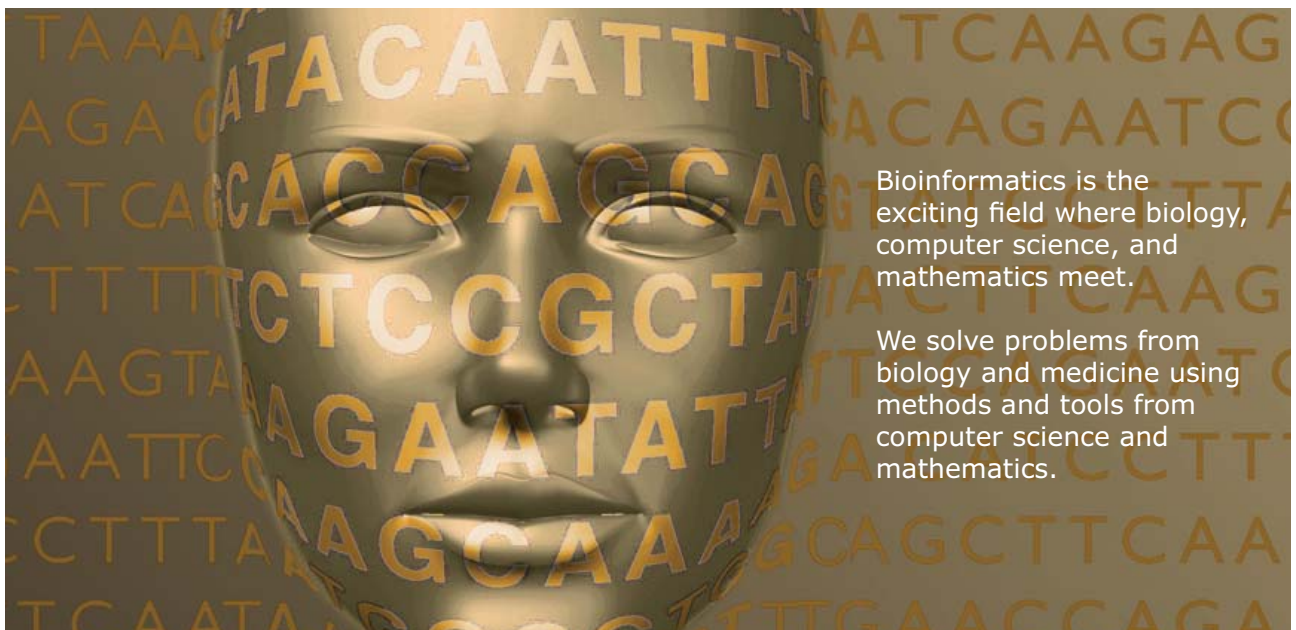

Bioinformatics is the exciting field where biology, computer science, and mathematics meet.

We solve problems from biology and medicine using methods and tools from computer science and mathematics.

Read more about this and our other international masters degree programmes at [www.uu.se/master](http://www.uu.se/master)



Click on the ad to read more

**Problem 3.36:** The protein travels the distance  $d = 2.4 \times 10^{-2} \text{ m}$  in the time  $t = 3.4 \cdot 3600 \text{ s} = 1.22 \times 10^4 \text{ s}$ . The drift speed of the protein follows  $v_d = d/t$ , or

$$v_d = \frac{2.4 \times 10^{-2} \text{ m}}{1.22 \times 10^4 \text{ s}} = 2.0 \times 10^{-6} \frac{\text{m}}{\text{s}}.$$

The strength of the electric field is  $E = 5.2 \times 10^2 \text{ V/m}$ . The net force on the protein is zero,  $F_{\text{net}} = QE - 6\pi\eta av_t = 0$ . The radius of the sphere follows  $a = QE/6\pi\eta v_t$  so that

$$a = \frac{100 \cdot 1.602 \times 10^{-19} \text{ C} \cdot 5.2 \times 10^2 \text{ V/m}}{6\pi \cdot 2.0 \times 10^{-7} \text{ m/s}} = 2.3 \times 10^{-8} \text{ m}.$$

We find the radius of the larger protein  $a' = 1.25 a$ ,

$$a' = 1.25 \cdot 2.3 \times 10^{-8} \text{ m} = 2.8 \times 10^{-8} \text{ m}.$$

We observe that the terminal speed is inversely proportional to the radius. We thus get  $v'_t/v_t = a/a'$ , or  $v'_t = (a/a')v_t$ ,

$$v'_t = \frac{1}{1.25} 2.0 \times 10^{-6} \frac{\text{m}}{\text{s}} = 1.6 \times 10^{-6} \frac{\text{m}}{\text{s}}.$$

In the time  $t = 3.4 \text{ h}$ , the other protein would travel  $d' = 2.4 \text{ mm}/1.25 = 1.9 \text{ cm}$ . Thus, the separation of the two proteins is  $\Delta = d - d' = 2.4 \text{ cm} - 1.9 \text{ cm} = 5.0 \text{ mm}$ .

**Problem 3.37:** Since an electron carries the charge  $e = 1.602 \times 10^{-19} \text{ C}$ , the number of electrons flowing through a cross-section per second follows from the current  $N_e/t = I/e$ ,

$$\frac{N_e}{t} = \frac{1.0 \text{ C/s}}{1.602 \times 10^{-19} \text{ C}} = 6.21 \times 10^{18} \text{ s}^{-1}.$$

Since each copper atom contributes one conduction electron, the volume per electron is equal to the volume of a single copper atom is  $4\pi a^3/3$ . This gives the volume flow rate of electrons:  $V_e/t = (4\pi a^3/3) \cdot N_e/t$ ,

$$\frac{V_e}{t} = \frac{4\pi}{3} (0.36 \times 10^{-9} \text{ m})^3 \cdot 6.21 \times 10^{18} \text{ s}^{-1} = 1.21 \times 10^{-9} \frac{\text{m}^3}{\text{s}}.$$

The volume flow rate determines the drift velocity of electrons inside the copper wire:  $V_e/t = Av_d$ , where  $A = \pi(d/2)^2$  is the crosssectional area of the wire. We find the drift velocity of electrons in copper:  $v_d = (V_e/t)/A$ ,

$$v_d = \frac{1.21 \times 10^{-9} \text{ m}^3/\text{s}}{\pi(2.05 \times 10^{-3} \text{ m}/2)^2} = 3.7 \times 10^{-4} \frac{\text{m}}{\text{s}}.$$

We use  $\text{KE} = 3k_B T/2$  for the kinetic energy of a particle in thermal equilibrium at the absolute temperature  $T$ . Since  $T \simeq 300 \text{ K}$ , we find  $v_{\text{th}} = \sqrt{3k_B T/2m_e}$ , or

$$v_{\text{th}} = \sqrt{\frac{3 \cdot 1.38 \times 10^{-23} \text{ J/K} \cdot 300 \text{ K}}{2 \cdot 9.11 \times 10^{-31} \text{ kg}}} = 8.3 \times 10^4 \frac{\text{m}}{\text{s}}.$$

Thus, the drift speed of electrons is very small compared to the “typical” speed of an electron.

*Note:* The volume of a unit cell of copper is  $V_{\text{cell}} = a^3$  with four atoms in a unit cell. Thus the volume per electron  $a^3/4$  so that the volume flow rate is  $V_e/t = a^3/4 \cdot N_e/t = 7.2 \times 10^{-11} \text{ m}^3/\text{s}$ . The drift speed of electrons follows  $v_d = 2.2 \times 10^{-5} \text{ m/s}$ .

**Problem 3.38:** The rod slides down the track with constant velocity so that the acceleration is zero. Thus the net force on the rod is zero  $F_{\text{net}} = ma = 0$ . The forces on the rod are (1) the component of the weight parallel to the incline  $W_{\parallel} = mg \sin \theta$ ,

$$W_{\parallel} = 2.1 \times 10^{-3} \text{ kg} \cdot 9.8 \frac{\text{m}}{\text{s}^2} \sin 13^\circ = 4.63 \times 10^{-3} \text{ N},$$

and (2) the magnetic force  $F_{\text{mag}} = B \cos \theta I l$ , where  $I$  is the current through the rod. We set  $W_{\parallel} = F_{\text{mag}}$  and find  $I = W_{\parallel}/B \cos \theta l$  so that

$$I = \frac{4.63 \times 10^{-3} \text{ N}}{3.2 \times 10^{-3} \text{ T} \cos 13^\circ \cdot 0.23 \text{ m}} = 6.93 \text{ A}.$$

We use the RHR to find that the current flows *clockwise* when viewed from the top. The voltage across the resistor follows  $V_R = RI = 4.1 \text{ m}\Omega \cdot 6.93 \text{ A} = 28.4 \text{ mV}$ . Because the resistor is parallel to the rod, we find the induced electromotive force (EMF)  $\mathcal{E} = V_R = 28.4 \text{ mV}$ . The electromotive force (EMF) across the rod is determined by the speed of the rod  $v_t$  is the speed of the rod  $\mathcal{E} = Blv \cos \theta$ , so that  $v = \mathcal{E}/Bl \cos \theta$  and find the terminal speed:

$$v = \frac{28.4 \times 10^{-3} \text{ V}}{3.2 \times 10^{-3} \text{ T} \cdot \cos 13^\circ \cdot 0.23 \text{ m}} = 42.5 \frac{\text{m}}{\text{s}}.$$

We note that the terminal speed is proportional to the resistance  $R$  of the resistor connecting the two rails.

**Problem 3.39:** The change in the kinetic energy of the oxygen ion is given by  $\Delta \text{KE} = m(v^2 - v_0^2)/2$ ,

$$\Delta \text{KE} = \frac{16 \cdot 1.67 \times 10^{-27} \text{ kg}}{2} \left[ \left( 6800 \frac{\text{m}}{\text{s}} \right)^2 - \left( 4300 \frac{\text{m}}{\text{s}} \right)^2 \right] = 3.7 \times 10^{-19} \text{ J}.$$

The conservation of energy yields:  $\Delta \text{KE} = -\Delta \text{EPE}$ . Since  $\Delta \text{EPE} = q\Delta V = (-e)\Delta V = eV_0$ , we find  $V_0 = -\Delta \text{KE}/e$ :

$$V_0 = -\frac{3.7 \times 10^{-19} \text{ J}}{1.602 \times 10^{-19} \text{ C}} = -2.3 \text{ V}.$$

The capacitance of the parallel-plate capacitor follows  $C = \epsilon_0 A/d$

$$C = 8.85 \times 10^{-12} \frac{\text{C}^2}{\text{N m}^2} \cdot \frac{0.15 \text{ m}^2}{0.08 \text{ m}} = 1.66 \times 10^{-11} \text{ F}.$$

The voltage across the capacitor is  $\Delta V = 2V_0 = -4.6 \text{ V}$ . The charge on the capacitor follows  $Q = CV$ ,

$$Q = 1.66 \times 10^{-11} \text{ F} \cdot 4.6 \text{ V} = 7.6 \times 10^{-11} \text{ C}.$$

Since the positively-charged oxygen ion travels to the left plate,  $\Delta x = -0.04\text{ m}$ , the left plate is *negatively* charged. Since magnitude of the electric field is determined by the applied voltage  $V$  and the distance between the plates  $d$ ,  $E = V/d$ , we find

$$E = \frac{4.6\text{ V}}{0.08\text{ m}} = 57.5 \frac{\text{V}}{\text{m}}.$$

We find the acceleration of the electron  $a = eE/m$ , or

$$a = \frac{1.6 \times 10^{-19}\text{ C} \cdot 57.5\text{ V/m}}{2.7 \times 10^{-26}\text{ kg}} = 3.4 \times 10^8 \frac{\text{m}}{\text{s}^2}.$$

We write the displacement along the  $x$ -axis:  $\Delta x = v_{0,x}t - at^2/2$  so that  $v_{0,x} = \Delta x/t + at/2$ :

$$v_{0,x} = -\frac{4.0 \times 10^{-2}\text{ m}}{8.0 \times 10^{-6}\text{ s}} + \frac{1}{2} 3.4 \times 10^8 \frac{\text{m}}{\text{s}^2} \cdot 8.0 \times 10^{-6}\text{ s} = 3.6 \times 10^3 \frac{\text{m}}{\text{s}}.$$

We find  $y$ -component of the initial velocity  $v_{0,y} = \sqrt{v_0^2 - v_{0,x}^2}$ ,

$$v_{0,y} = \pm \sqrt{\left(4.3 \times 10^3 \frac{\text{m}}{\text{s}}\right)^2 - \left(3.6 \times 10^3 \frac{\text{m}}{\text{s}}\right)^2} = 2.4 \times 10^3 \frac{\text{m}}{\text{s}}.$$

**Nido**

**Luxurious accommodation**

**Central zone 1 & 2 locations**

**Meet hundreds of international students**

**BOOK NOW and get a £100 voucher from voucherexpress**

**Nido Student Living - London**

**Visit [www.NidoStudentLiving.com/Bookboon](http://www.NidoStudentLiving.com/Bookboon) for more info.**

**+44 (0)20 3102 1060**





The displacement along the  $y$ -axis [perpendicular to the electric field] follows  $\Delta y = v_{0,y}\Delta t$ ,

$$\Delta y = \pm 2.4 \times 10^3 \frac{\text{m}}{\text{s}} \cdot 8.0 \times 10^{-6} \text{ s} = \pm 1.9 \text{ cm}.$$

Note that the sign of the vertical displacement  $\Delta y$  is not determined.

**Problem 3.40:** We find the area  $A = \pi r^2 = \pi(5.0 \times 10^{-2} \text{ m})^2 = 7.9 \times 10^{-3} \text{ m}^2$ . We find the magnitude of the magnetic flux,  $|\Phi| = BA$ ,

$$|\Phi| = 2.0 \text{ T} \cdot 7.9 \times 10^{-3} \text{ m}^2 = 1.6 \times 10^{-2} \text{ T} \cdot \text{m}^2.$$

Since the coil is flipped around, the change in the magnetic flux:  $\Delta\Phi = 2BA$ . Faraday's law then gives the induced EMF:  $|\mathcal{E}| = \Delta\Phi/\Delta t$ ,

$$|\mathcal{E}| = \frac{2 \cdot 1.6 \times 10^{-2} \text{ T} \cdot \text{m}^2}{0.5 \text{ s}} = 6.3 \times 10^{-2} \text{ V}.$$

We find the power  $P = V^2/R$  so that

$$P = \frac{(6.4 \times 10^{-2} \text{ V})^2}{0.1 \Omega} = 4.1 \times 10^{-2} \text{ W}.$$

The energy dissipated in the wire loop is given by  $Q_{\text{diss}} = P\Delta t$ ,

$$Q_{\text{diss}} = 4.1 \times 10^{-2} \text{ W} \cdot 0.5 \text{ s} = 2.1 \times 10^{-2} \text{ J}.$$

The dissipated energy is independent of the direction of the current. This energy is supplied by *us*, as we twirl the loop (one feels 'resistance' when cranking the coils inside an electro-motor).

*Note:* We assume that the induced EMF is constant. If the wire loop is rotated at a constant angular speed, the dissipated power is greater by a factor  $\pi^2/8$ .

**Problem 4.1:** Since the tension in the string is  $F = mg = 1.18 \text{ N}$ , we find the wave speed along the string  $v = \sqrt{F/m/L}$

$$v = \sqrt{\frac{1.18 \text{ N}}{(1.5 \times 10^{-3} \text{ kg})/(0.84 \text{ m})}} = 25.7 \frac{\text{m}}{\text{s}}$$

We use the condition  $L = 3\lambda/2$  so that  $\lambda = 2L/3 = 2 \cdot 0.84 \text{ m}/3 = 0.56 \text{ m}$ . Since  $v = \lambda f$ , the frequency of the harmonic motion of the beads follows,  $f = v/\lambda$ ,

$$f = \frac{25.7 \text{ m/s}}{0.56 \text{ m}} = 45.6 \text{ Hz}$$

The *up-and-down* motion of the string is harmonic [oscillatory]. Since the amplitude is  $A = 4 \text{ mm} = 4.0 \times 10^{-4} \text{ m}$ , we find the speed in transverse direction:

$$v_{\text{max}} = \omega A = 2\pi \cdot 45.6 \text{ s}^{-1} \cdot 0.004 \text{ m} = 1.15 \frac{\text{m}}{\text{s}},$$

and the acceleration:

$$a_{\text{max}} = (2\pi \cdot 45.6 \text{ s}^{-1})^2 \cdot 0.004 \text{ m} = 328 \frac{\text{m}}{\text{s}^2}.$$

The acceleration at the nodes is zero so that average acceleration is half of its maximum value:

$$a_{\text{ave}} \simeq \frac{328 \text{ m/s}^2}{2} = 164 \frac{\text{m}}{\text{s}^2}.$$

The mass of one loop is one-third of the mass of the entire string  $m' = 1.5 \text{ g}/3 = 5.0 \times 10^{-4} \text{ kg}$ . We obtain an estimate for the force in *up-and-down* direction:

$$F_{\text{up-down}} = m' a_{\text{ave}} = 5.0 \times 10^{-4} \text{ kg} \cdot 164 \frac{\text{m}}{\text{s}^2} = 0.083 \text{ N}.$$

We compare with the tension in the rope:

$$\kappa = \frac{F_{\text{up-down}}}{T} = \frac{0.083 \text{ N}}{1.18 \text{ N}} \simeq 0.07.$$

That is, the force in *up-and-down* direction exerted by the vibrator is about 7% of the tension in the rope. This seems reasonable.

**Problem 4.2:** The distances are determined by half the travel time of the echoes:  $d = vt/2$ , so that

$$d_1 = \frac{1,540 \text{ m/s} \cdot 5.2 \times 10^{-5} \text{ s}}{2} = 0.040 \text{ m},$$

$$d_2 = \frac{1,540 \text{ m/s} \cdot 9.6 \times 10^{-5} \text{ s}}{2} = 0.074 \text{ m}.$$

We obtain the size of the organ  $d = d_2 - d_1$ ,

$$d = 0.074 \text{ m} - 0.040 \text{ m} = 0.034 \text{ m} = 3.4 \text{ cm}.$$

The frequency of the ultrasound is given by  $f = v/\lambda$ ,

$$f = \frac{1.54 \times 10^3 \text{ m/s}}{5.6 \times 10^{-4} \text{ m}} = 2.75 \times 10^6 \text{ Hz} = 2.75 \text{ MHz.}$$

The period follows  $T = 1/f$ ,

$$T = \frac{1}{2.75 \times 10^6 \text{ s}} = 3.6 \times 10^{-7} \text{ s.}$$

Since  $\Delta = 9.6 \times 10^{-5} \text{ s} - 5.2 \times 10^{-5} \text{ s} = 4.4 \times 10^{-5} \text{ s}$ , we find the number of oscillations  $n = \Delta t/T$ ,

$$n = \frac{4.4 \times 10^{-5} \text{ s}}{3.6 \times 10^{-7} \text{ s}} = 121.$$

Note that the time delay is measured based on the number of oscillations emitted.



**Brain power**

By 2020, wind could provide one-tenth of our planet's electricity needs. Already today, SKF's innovative know-how is crucial to running a large proportion of the world's wind turbines.

Up to 25 % of the generating costs relate to maintenance. These can be reduced dramatically thanks to our systems for on-line condition monitoring and automatic lubrication. We help make it more economical to create cleaner, cheaper energy out of thin air.

By sharing our experience, expertise, and creativity, industries can boost performance beyond expectations. Therefore we need the best employees who can meet this challenge!

The Power of Knowledge Engineering

Plug into The Power of Knowledge Engineering.  
Visit us at [www.skf.com/knowledge](http://www.skf.com/knowledge)

**SKF**

**Problem 4.3:** The wavelength follows from the condition:  
 $\lambda_3 = v/f_3$ , or

$$\lambda_3 = \frac{343 \text{ m/s}}{576 \text{ Hz}} = 0.595 \text{ m}.$$

Since  $L = 3\lambda_3/4$ , we obtain the length of the organ pipe:

$$L = \frac{3}{4} \cdot 0.595 \text{ m} = 0.447 \text{ m}.$$

The longest wavelength follows from  $L = \lambda'_1/2$  so that

$$\lambda'_1 = 2 \cdot 0.447 \text{ m} = 0.893 \text{ m},$$

so that for the frequency  $f'_1 = v/\lambda'_1$ ,

$$f'_1 = \frac{343 \text{ m/s}}{0.893 \text{ m}} = 387 \text{ Hz}.$$

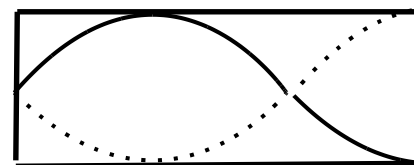

**Problem 4.4:** We find the wave speed from the depth of water  $v = \sqrt{gd}$  so that

$$v = \sqrt{9.8 \frac{\text{m}}{\text{s}^2} \cdot 0.45 \text{ m}} = 1.2 \frac{\text{m}}{\text{s}}.$$

Colby and Harry are a wavelength apart:  $\lambda = 1.61 \text{ m}$ . Then for the frequency  $f = v/\lambda$ ,

$$f = \frac{1.2 \text{ m/s}}{1.61 \text{ m}} = 0.75 \text{ Hz}.$$

The period is given by  $T = 1/f = 1/(0.75 \text{ s}^{-1}) = 1.34 \text{ s}$ . The number of crests hitting their legs follows

$$n = \frac{60 \text{ s}}{1.34 \text{ s}} = 44.7 \simeq 45.$$

We find the wave speed in the deeper water:  $v' = \sqrt{gd} = \sqrt{9.8 \text{ m/s}^2 \cdot 1.3 \text{ m}} = 3.6 \text{ m/s}$ . Since the frequency is fixed, we find the wavelength:

$$\lambda' = \frac{v'}{f} = \frac{3.6 \text{ m/s}}{0.75 \text{ s}^{-1}} = 4.8 \text{ m}.$$

We obtain  $\lambda/d \simeq 3$  so that  $d \simeq \lambda'/3$  and Harry is close to a trough.

**Problem 4.5:** We calculate the mass per unit length  $m/L = (4.2 \times 10^{-4} \text{ kg})/(2.0 \times 10^{-2} \text{ m}) = 2.1 \times 10^{-2} \text{ kg/m}$  and find the wave speed  $v = \sqrt{T/(m/L)}$ ,

$$v = \sqrt{\frac{6.2 \text{ N}}{2.1 \times 10^{-2} \text{ kg/m}}} = 17.2 \frac{\text{m}}{\text{s}}.$$

We obtain the frequency  $f = v/\lambda$  so that

$$f = \frac{17.2 \text{ m/s}}{0.34 \text{ m}} = 50.5 \text{ Hz}.$$

Because the motion of each bead is oscillatory, the maximum speed of a bead depends on the amplitude and angular frequency  $v_{\max} = A\omega$  so that

$$v_{\max} = 4.1 \times 10^{-3} \text{ m} \cdot 2\pi 50.5 \text{ Hz} = 1.3 \frac{\text{m}}{\text{s}}.$$

Similarly the maximum acceleration is given by  $a_{\max} = \omega^2 A$  so that the force on a bead follows  $F = ma$ ,

$$F = 4.2 \times 10^{-4} \text{ kg} \cdot (2\pi 50.5 \text{ Hz})^2 \cdot 4.1 \times 10^{-3} \text{ m} = 0.17 \text{ N}.$$

**Problem 4.6:** Since  $f = v/2L$ , the wave speed follows  $v = 2L f$ ,

$$v = 2 \cdot 0.14 \text{ m} \cdot 96 \text{ Hz} = 26.9 \frac{\text{m}}{\text{s}}.$$

Since the wave speed is given by  $v = \sqrt{T/(m/L)}$  so that the tension in the string follows  $T_0 = (m/L)v^2$ ,

$$T_0 = 1.4 \times 10^{-8} \frac{\text{kg}}{\text{m}} \cdot \left(26.9 \frac{\text{m}}{\text{s}}\right)^2 = 1.0 \times 10^{-5} \text{ N}.$$

The wavelength is given by  $\lambda = 2L$ . The largest frequency follows from the shortest wavelength:

$$f_{\max} = \frac{26.9 \text{ m/s}}{2 \cdot 0.095 \text{ m}} = 141.6 \text{ Hz},$$

and the smallest frequency is determined by the longest wavelength:

$$f_{\min} = \frac{26.9 \text{ m/s}}{2 \cdot 0.195 \text{ m}} = 69.0 \text{ Hz}.$$

Reducing the tension by 20% yields the smallest tension  $T_{\min} = 0.8 T_0 = 0.8 \times 10^{-5} \text{ N}$  and  $T_{\max} = 1.2 T_0 = 1.2 \times 10^{-5} \text{ N}$ . We find the smallest frequency from the smallest tension and longest string:

$$f_{\min} = \frac{1}{2 \cdot 0.195 \text{ m}} \sqrt{\frac{0.8 \times 10^{-5} \text{ N}}{1.4 \times 10^{-8} \text{ kg/m}}} = 61.3 \text{ Hz},$$

and the largest frequency from largest tension and shortest string:

$$f_{\max} = \frac{1}{2 \cdot 0.095 \text{ m}} \sqrt{\frac{1.2 \times 10^{-5} \text{ N}}{1.4 \times 10^{-8} \text{ kg/m}}} = 154.0 \text{ Hz}.$$

**Problem 4.7:** The frequency from the wave speed and the wavelength when the boat is anchored:  $f = v/\lambda = (16.5 \text{ m/s})/(40.0 \text{ m}) = 0.41 \text{ Hz}$ . We then find for the time between crests  $T = 1/f$ ,

$$T = \frac{1}{0.41 \text{ Hz}} = 2.4 \text{ s}.$$

The observer [ship] travels towards the stationary source. We find the observed frequency  $f_o = f_s (1 + v_{\text{ship}}/v)$ ,

$$f_o = 0.41 \text{ Hz} \cdot \left( 1 + \frac{5.0 \text{ m/s}}{16.5 \text{ m/s}} \right) = 0.53 \text{ Hz}.$$

We find the time between crests  $T_o = 1/f_o$ ,

$$T_o = \frac{1}{0.53 \text{ Hz}} = 1.87 \text{ s}.$$

We find the period from the number of crests per minute:  $T'_o = 60 \text{ s}/22$ . We thus find the frequency  $f'_o = 1/T'_o$ ,

$$f'_o = \frac{22}{60 \text{ s}} = 0.37 \text{ Hz}.$$

Note that  $f'_o < f$ , so that the ship is traveling *east*-ward. We find the ratio of the frequencies,

$$\frac{f'_o}{f} = \frac{0.37 \text{ Hz}}{0.41 \text{ Hz}} = 0.89.$$

Since  $f'_o/f = 1 - v'_{\text{ship}}/v$ , we find  $v'_{\text{ship}}/v = 1 - 0.89 = 0.11$ , so that the speed of the ship follows

$$v'_{\text{ship}} = 0.11 \cdot 16.5 \frac{\text{m}}{\text{s}} = 1.82 \frac{\text{m}}{\text{s}}.$$

**Problem 4.8:** We calculate the period of the ultrasound:

$$T = \frac{1}{f} = \frac{1}{3.0 \times 10^6 \text{ Hz}} = 3.33 \times 10^{-7} \text{ s}.$$

Thus, we get the time difference  $\Delta t = nT$ ,

$$\Delta t = 84 \cdot 3.33 \times 10^{-7} \text{ s} = 2.8 \times 10^{-5} \text{ s}.$$

We find  $d = v \cdot \Delta t$ ,

$$d = 1,540 \frac{\text{m}}{\text{s}} \cdot 2.8 \times 10^{-5} \text{ s} = 4.3 \text{ cm}.$$

The size of the organ is  $d/2 \simeq 2.2 \text{ cm}$ . We find the wavelength  $\lambda = v/f$ ,

$$\lambda = \frac{1540 \text{ m/s}}{3.0 \times 10^6 \text{ Hz}} \simeq 0.5 \text{ mm}.$$

The smallest organ that can be detected has size  $d' \simeq 2\lambda \simeq 1.0 \text{ mm}$ . The time delay follows  $\Delta t' = 2d'/v = 2\lambda/v = 2/f$ , and the number of oscillations follows  $n' = 2\Delta t'/T$ ,

$$n' = 2f \Delta t' = 2f \cdot \frac{2}{f} = 4.$$

That is, about four oscillations.

**Problem 4.9:** We find the intensity  $S = \sigma T^4$ ,

$$S = 5.67 \times 10^{-8} \frac{\text{W}}{\text{m}^2 \text{K}^4} \cdot (450 \text{ K})^4 = 2325 \frac{\text{W}}{\text{m}^2}.$$

Since  $S = cu$ , the energy density follows  $u = S/c$ :

$$u = \frac{2325 \text{ W/m}^2}{3.0 \times 10^8 \text{ m/s}} = 7.75 \times 10^{-6} \frac{\text{J}}{\text{m}^3}.$$

The total (electric *plus* magnetic) energy density is determined by the strength of the electric field:  $u = \epsilon_0 E_{\text{rms}}^2$  so that

$$E_{\text{rms}} = \sqrt{\frac{u}{\epsilon_0}} = \sqrt{\frac{7.75 \times 10^{-6} \text{ J/m}^3}{8.85 \times 10^{-12} \text{ C}^2/(\text{N m}^2)}} = 936 \frac{\text{N}}{\text{C}}.$$

The volume of the oven is given by  $V = 0.6 \text{ m} \cdot 0.4 \text{ m} \cdot 0.5 \text{ m} = 0.12 \text{ m}^3$ . We find the total energy of the electromagnetic radiation inside the oven  $U = uV$ ,

$$U_{\text{rad}} = 7.75 \times 10^{-6} \frac{\text{J}}{\text{m}^3} \cdot 0.12 \text{ m}^3 = 9.3 \times 10^{-7} \text{ J}.$$

We treat air as an ideal gas:  $U_{\text{air}} = (5/2)nRT = (5/2)PV$  so that

$$U_{\text{air}} = \frac{5}{2} 1.0 \times 10^5 \text{ Pa} \cdot 0.12 \text{ m}^3 = 3.0 \times 10^4 \text{ J}.$$

Thus, the heat contained in the air is much bigger than the energy of the radiated electromagnetic wave.

*Note:* That's why convection ovens are helpful since air is circulated around and thus also contribute to heating the food.

**GET A MASTER'S DEGREE IN UMEÅ!**

- modern campus • world class research • 32 000 students
- top class teachers • ranked nr 1 in Sweden by international students

**Master's programmes:**

- Architecture
- Industrial Design
- Science
- Engineering

Download brochure here!

UMEÅ UNIVERSITY  
FACULTY OF SCIENCE & TECHNOLOGY



**Problem 4.10:** We start from the power of the lens in the eye:  $P = 1/f$  and the image is formed on the retina:  $d_i = 0.018 \text{ m}$ . The minimum power  $P_{\min}$  yields the farthest object distance

$$\frac{1}{d_{o,\max}} = 56 \text{ m}^{-1} - \frac{1}{0.018 \text{ m}} = \frac{1}{2.25 \text{ m}},$$

while the maximum power  $P_{\max}$  gives the closest object distance

$$\frac{1}{d_{o,\min}} = 58 \text{ m}^{-1} - \frac{1}{0.018 \text{ m}} = \frac{1}{0.41 \text{ m}}.$$

We identify these distances with the near- and farpoints: Colby's nearpoint and farpoint are 41 cm and 2.25 m from her eyes, respectively: she is both *near* and *farsighted* and wears *bifocals*. For the distance correction [nearsightedness - upper part]: We find the top-part (for distance): the object is infinitely far  $d_o = \infty$  and the image is at her farpoint  $d_i = -(2.25 \text{ m} - 0.02 \text{ m}) = -2.23 \text{ m}$ . Inserted into the lens equation gives  $1/f = 1/d_o + 1/d_i$ ,

$$\frac{1}{f_{\text{top}}} = \frac{1}{(-2.23 \text{ m})} = -0.45 \text{ m}^{-1}.$$

For the reading correction [farsightedness - the lower part]. The object distance is the distance from the book to the eye glass:  $d_o = 0.2 \text{ m} - 0.02 \text{ m} = 0.18 \text{ m}$  and the image is formed at her nearpoint:  $d_i = -(0.41 \text{ m} - 0.02 \text{ m}) = -0.39 \text{ m}$ . The lens equation gives  $1/f = 1/d_o + 1/d_i$ ,

$$\frac{1}{f_{\text{bottom}}} = \frac{1}{0.18 \text{ m}} + \frac{1}{(-0.39 \text{ m})} = +3.0 \text{ m}^{-1}.$$

When she looks at Harry [object] an image is formed on her retina by adjusting the power of the lens in her eyes. The object distance is now given by:  $d_o = 2.0 \text{ m} - 0.02 \text{ m} = 1.98 \text{ m}$ . Colby looks through the top part of her bifocals. The image distance of the (intermediate) image formed by divergent lens is:

$$\frac{1}{d_i} = -0.45 \text{ m}^{-1} - \frac{1}{1.98 \text{ m}} = \frac{1}{-1.05 \text{ m}}.$$

This intermediate image is the object for the lens in her eyes:  $d_o = (1.05 \text{ m} + 0.02 \text{ m}) = 1.07 \text{ m}$ . Since the image is at the retina  $d_i = 0.018 \text{ m}$ , so that the necessary power in the lens in her eyes follows from the lens equation  $1/f = 1/d_o + 1/d_i$ ,

$$\frac{1}{f_{\text{eye}}} = \frac{1}{1.07 \text{ m}} + \frac{1}{0.018 \text{ m}} = 56.5 \text{ m}^{-1},$$

so that  $P_{\min} < P < P_{\max}$ , as it should.

**Problem 4.11:** We find the wavelength from the speed of light and the frequency:  $\lambda = c/f$ ,

$$\lambda = \frac{3.0 \times 10^8 \text{ m/s}}{5.25 \times 10^{14} \text{ s}^{-1}} = 571 \text{ nm}$$

Since the direction of the first minimum is given by  $\sin \theta_{1,\min} = \lambda/2d$ , we find

$$\sin \theta_{1,\min} = \frac{5.71 \times 10^{-7} \text{ m}}{2 \cdot 3.5 \times 10^{-5} \text{ m}} = 8.2 \times 10^{-3}.$$



The coordinate  $x$  of the first dark fringe follows:  $x = D \tan \theta_{1,\min}$ ,

$$x \simeq 1.5 \text{ m} \cdot 8.2 \times 10^{-3} = 12 \text{ mm}.$$

We now consider the situation when double-slit experiment is immersed in fluid. We find  $\theta' \simeq \tan \theta'$ , or

$$\theta' \simeq \frac{9 \text{ mm}}{1500 \text{ mm}} = 6.0 \times 10^{-3}.$$

The wavelength of light follows  $\lambda' \simeq 2d\theta'$ ,

$$\lambda' \simeq 2 \cdot 3.5 \times 10^{-5} \cdot 6.0 \times 10^{-3} = 420 \text{ nm}.$$

The speed of light in the fluid is then given by  $v = \lambda' f$

$$v = 4.2 \times 10^{-7} \text{ m} \cdot 5.25 \times 10^{14} \text{ s}^{-1} = 2.2 \times 10^8 \frac{\text{m}}{\text{s}}.$$

The index of refraction  $n = c/v$  follows:

$$n = \frac{3.0 \times 10^8 \text{ m/s}}{2.2 \times 10^8 \text{ m/s}} = 1.36.$$



 **Scholarships**

**Open your mind to new opportunities**

With 31,000 students, Linnaeus University is one of the larger universities in Sweden. We are a modern university, known for our strong international profile. Every year more than 1,600 international students from all over the world choose to enjoy the friendly atmosphere and active student life at Linnaeus University. Welcome to join us!

**Linnæus University**  
Sweden

**Lnu.se**

**Bachelor programmes in**  
*Business & Economics | Computer Science/IT | Design | Mathematics*

**Master programmes in**  
*Business & Economics | Behavioural Sciences | Computer Science/IT | Cultural Studies & Social Sciences | Design | Mathematics | Natural Sciences | Technology & Engineering*

**Summer Academy courses**

**Problem 4.12:** We find the smallest wavelength:  $\lambda_{\min} = v/f_{\max}$ ,

$$\lambda_{\min} = \frac{343 \text{ m/s}}{65.4 \text{ s}^{-1}} = 5.25 \text{ m}$$

and the longest wavelength:  $\lambda_{\max} = v/f_{\min}$ ,

$$\lambda_{\max} = \frac{343 \text{ m/s}}{32.7 \text{ s}^{-1}} = 10.5 \text{ m}$$

Since  $L = \lambda/2$ , we obtain the smallest and largest pipe to produce  $C_1$ :

$$L_{\min} = 2.62 \text{ m} \quad L_{\max} = 5.25 \text{ m}.$$

Since  $L = \lambda/2$ , we get  $\lambda_{\min} = 0.32 \text{ m}$  and  $\lambda_{\max} = 2.8 \text{ m}$ . Thus the range of frequencies follows  $F_{\min/\max} = v/\lambda_{\max/\min}$ ,

$$F_{\min} = \frac{343 \text{ m/s}}{2.8 \text{ m}} = 122.5 \text{ Hz}, \quad F_{\max} = \frac{343 \text{ m/s}}{0.32 \text{ m}} = 1072 \text{ Hz}.$$

The lowest complete octave is  $C_3$  [Small]. Organs are not suitable instruments for home use unless one has a living room that is a replicate of a music hall.

**Problem 4.13:** The diameter of the telescope  $D = 6.0 \text{ m}$  limits the resolving power:  $1.22\lambda/D = 2r/R$ , where  $r$  is the radius of the exoplanet and  $R$  is the distance to the Earth. We solve the diameter of the planet  $2r = 1.22(\lambda/D)R$ ,

$$2r = 1.22 \frac{5.3 \times 10^{-7} \text{ m}}{6.0 \text{ m}} \cdot 2.74 \times 10^{16} \text{ m} = 2.9 \times 10^9 \text{ m} = 2.95 \times 10^6 \text{ km}.$$

This planet would be 21-times larger than planet Jupiter. We solve for wavelength  $\lambda = (D/1.22)2r_{\text{jup}}/R$ ,

$$\lambda = \frac{6.0 \text{ m}}{1.22} \cdot \frac{2 \cdot 70 \times 10^6 \text{ m}}{2.74 \times 10^{16} \text{ m}} = 25 \text{ nm}.$$

This would be in the X-ray part of electromagnetic spectrum. Finally, we obtain the distance to the Earth  $R = 2r \cdot (D/1.22\lambda)$ ,

$$R = 2 \cdot 70 \times 10^6 \text{ m} \cdot \frac{6 \text{ m}}{1.22 \cdot 5.3 \times 10^{-7} \text{ m}} = 1.3 \times 10^{15} \text{ m}.$$

This is about 5% of the distance to Proxima Centauri.

**Problem 4.14:** The blackboard is the object so that the object distance follows  $d_o = 2.28 \text{ m}$ . The prescription gives the focal length,  $1/f = -0.75 \text{ m}^{-1}$ . The image distance follows  $1/d_i = 1/f - 1/d_o$ ,

$$\frac{1}{d_i} = -0.75 \text{ m}^{-1} - \frac{1}{2.28 \text{ m}} = -\frac{1}{0.84 \text{ m}}.$$

Thus, the far point is 86 cm in front of her eyes. The intermediate image is the object for the lens in her eyes so that the object distance is  $d'_o = 0.86$  m. The image is formed on her retina:  $d'_i = 0.019$  m. The strength of the lens in her eyes follows from the lens equation  $1/f = 1/d_o + 1/d_i$ ,

$$\frac{1}{f} = \frac{1}{0.86 \text{ m}} + \frac{1}{0.019 \text{ m}} = 53.8 \text{ diopters.}$$

Colby now looks at the lighthouse which can be considered as being infinitely far away  $d_o = \infty$ . The lens equation then gives  $1/d_i = 1/f$  so that  $d = f$ , or

$$d_i = 1.85 \text{ cm.}$$

Thus, the image is formed 0.05-mm in front of her retina. The image is not formed on the retina; Colby sees the Lighthouse “fuzzy.” We find the object distance:  $d_o = \infty$  and  $d_i = -0.84$  m so that

$$\frac{1}{f} = 0 + \frac{1}{(-0.84 \text{ m})} = -1.2 \text{ diopters.}$$

**Problem 4.15:** Elementary geometry yields the distances:

$$d_1 = 3.0 \text{ cm} \cdot \tan 54^\circ = 4.13 \text{ cm,}$$

and

$$d_2 = \frac{1.0 \text{ cm}}{\cos 54^\circ} = 1.70 \text{ cm.}$$

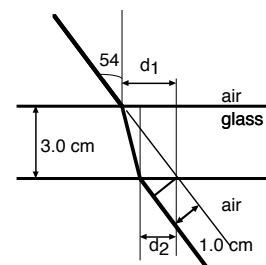

The refracted angle follows:

$$\tan \theta_2 = \frac{d_1 - d_2}{3.0 \text{ cm}} = \frac{4.13 \text{ cm} - 1.70 \text{ cm}}{3.0 \text{ cm}} = 0.81,$$

so that  $\theta_2 = 39^\circ$ . We use Snell’s law,  $\sin 54^\circ = n \sin 39^\circ$ , to find the index of refraction:

$$n = \frac{\sin 54^\circ}{\sin 39^\circ} = 1.29.$$

We find  $\sin \theta'_2 = \sin 64^\circ / 1.29$  so that  $\theta'_2 = 44^\circ$ . Then

$$d'_1 = 3.0 \text{ cm} \cdot \tan 64^\circ = 6.15 \text{ cm.}$$

and

$$d'_2 = d'_1 - 3.0 \text{ cm} \cdot \tan 44^\circ = 3.25 \text{ cm.}$$

The thickness of the slab follows:

$$d' = d'_2 \cdot \cos 64^\circ = 1.4 \text{ cm.}$$

**Problem 4.16:** Step 1: Since the (virtual) image is smaller in size, the image is closer to the lens than the object: the lens is *divergent*:

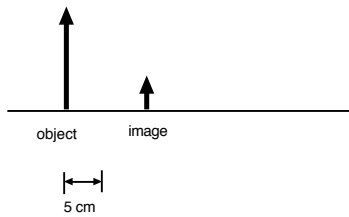

Step 2: Draw ray #3: the intersect with the principal axis gives the position of the lens. We find  $d_i = -6$  cm and  $d_o = 18$  cm

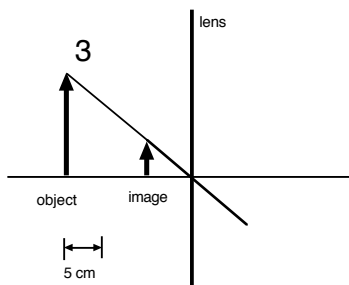

Step 3: Draw the outgoing ray #2 and find the intersection with the lens. Now draw the incoming ray #2. The focal length is  $f = -6$  cm

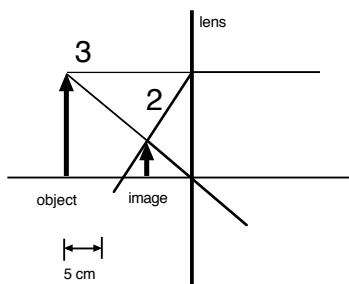

Step 4 (not necessary): Draw the incoming ray #1 and find the intersection with the lens. Now draw the outgoing ray #1. The focal length is  $f = -6$  cm

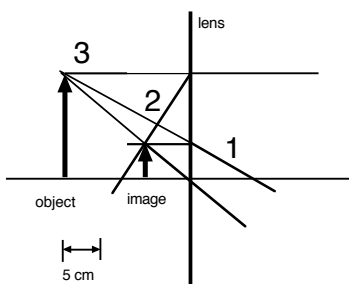

We obtain  $d_o + d_i = 5$  cm. We then find (we drop the units!)

$$\frac{1}{d_o} + \frac{1}{10 - d_o} = \frac{1}{-6}$$

so that

$$d_o^2 - 5d_o - 30 = 0.$$

The solution of the quadratic equation is:

$$d_{o,\pm} = \frac{5 \pm \sqrt{25 - 4 \cdot (-30)}}{2} \simeq \frac{5 \pm 12}{2} = \begin{cases} 14.2 \\ -4.2 \end{cases}$$

We find  $d_o = 8.5$  and  $d_i = -3.5$ . The magnification follows  $m = -d_i/d_o$

$$m = -\frac{(-3.5 \text{ cm})}{8.5 \text{ cm}} = 0.41,$$

and the image height is given by  $h_i = 0.41 \cdot 15 \text{ cm} = 6 \text{ cm}$ .

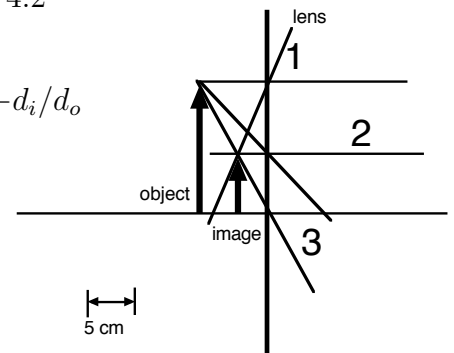



In the past four years we have drilled

# 89,000 km

That's more than **twice** around the world.

**Who are we?**  
We are the world's largest oilfield services company'. Working globally—often in remote and challenging locations—we invent, design, engineer, and apply technology to help our customers find and produce oil and gas safely.

**Who are we looking for?**  
Every year, we need thousands of graduates to begin dynamic careers in the following domains:

- Engineering, Research and Operations
- Geoscience and Petrotechnical
- Commercial and Business

**What will you be?**

**Schlumberger**

careers.slb.com

\*Based on Fortune 500 ranking 2011. Copyright © 2015 Schlumberger. All rights reserved.



**Problem 4.17:** The image is formed on the retina so that the image distance is given by  $d_i = 0.021$  m. The farpoint is determined by the minimum power of the lens in the eye. We use the lens equation  $1/d_{\text{far}} = P_{\text{min}} - 1/d_i$ ,

$$\frac{1}{d_{\text{far}}} = 47.6 \text{ m}^{-1} - \frac{1}{0.021 \text{ m}} = 0,$$

so that the farpoint is at infinity:  $d_{\text{far}} = \infty$ . Similarly, we find the near point is determined by the maximum power of the lens in the eye. We use the lens equation,  $1/d_{\text{near}} = P_{\text{max}} - 1/d_i$ ,

$$\frac{1}{d_{\text{near}}} = 49.5 \text{ m}^{-1} - \frac{1}{0.021 \text{ m}} = \frac{1}{0.53 \text{ m}},$$

so that the nearpoint is  $d_{\text{near}} = 0.53$  m. Harry is *farsighted*. Harry needs a prescription to read. The object distance is given by the desired reading distance,  $d_o = 25 \text{ cm} - 2.0 \text{ cm} = 23.0 \text{ cm}$  and the image by the correction lens is formed at the nearpoint  $d_i = -(53.0 \text{ cm} - 2.0 \text{ cm}) = -51.0 \text{ cm}$ . Then the power of his prescription is given by the lens equation

$$\frac{1}{f} = \frac{1}{0.23 \text{ m}} + \frac{1}{(-0.51 \text{ m})} = +2.4 \text{ diopters}.$$

**Problem 4.18:** We find the drawing:

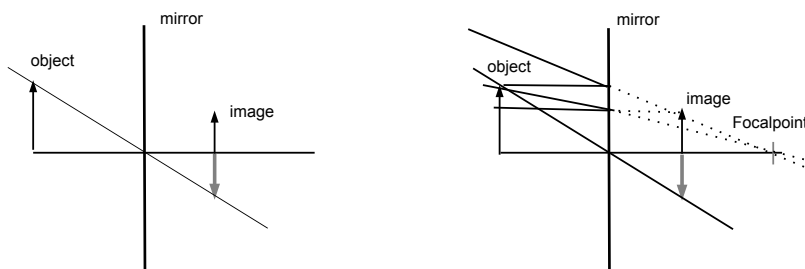

We read-off the focal length  $f = -7.0$  cm. The separation between object and image is given by  $d_o - d_i = 8.0$  cm, and the magnification is  $m = 2.0 \text{ cm}/3.0 \text{ cm} = 2/3$ . Since the magnification is also given by the ratio of image and object distances  $m = -d_i/d_o$ , we find  $d_i = -(2/3)d_o$ . It follows

$$d_o - \left(-\frac{2}{3}d_o\right) = \frac{5}{3}d_o = 8.0 \text{ cm}$$

so that  $d_o = 4.8$  cm and  $d_i = -3.2$  cm. We find the focal length,

$$\frac{1}{f} = \frac{1}{4.8 \text{ cm}} + \frac{1}{(-3.2 \text{ cm})} = \frac{1}{(-9.6 \text{ cm})}.$$

This is in roughly in agreement with the drawing. We obtain the image height  $h'_i = 1.0$  cm so that the magnification follows

$$m' = \frac{1.0 \text{ cm}}{3.0 \text{ cm}} = \frac{1}{3}.$$

We find  $d'_o/d'_i = -1/3$ . Inserted into the mirror equation:

$$\frac{1}{d'_o} + \left(-\frac{3}{d'_o}\right) = -\frac{2}{d'_o} = \frac{1}{(-9.6 \text{ cm})},$$

so that  $d'_o = 19.2 \text{ cm}$  and then  $d'_i = -19.2 \text{ cm}/3 = -6.4 \text{ cm}$ . We thus have to move the object 14.4-cm further away from the mirror. If we use instead  $f = -7.0 \text{ cm}$ , we get  $d''_o = 14.0 \text{ cm}$  and  $d''_i = -4.7 \text{ cm}$ .

**Problem 4.19:** Since  $c = \lambda f$ , the wavelength follows  $\lambda = c/f$ ,

$$\lambda = \frac{3.0 \times 10^8 \text{ m/s}}{4.4 \times 10^{14} \text{ s}^{-1}} = 682 \text{ nm}.$$

We find the resolving power  $\theta_{\min} = 1.22 \lambda/D$

$$\theta_{\min} = 1.22 \frac{6.82 \times 10^{-7} \text{ m}}{1.8 \times 10^{-3} \text{ m}} = 4.62 \times 10^{-4} \text{ rad}.$$

We obtain the angle  $\theta_{\min} = d/L$ , where  $L$  is the distance between the observer [you] and the car. Thus

$$L = \frac{d}{\theta_{\min}} = \frac{1.3 \text{ m}}{4.62 \times 10^{-4}} = 2.34 \text{ km}.$$

In the case when the pupil is enlarged three times:  $D' = 3D (= 5.4 \text{ mm})$ . Then  $\theta'_{\min} = \theta_{\min}/3$  so that  $L' = d/\theta'_{\min}$ ,

$$L' = 3 \frac{d}{\theta_{\min}} = 3L = 7.0 \text{ km}.$$

## Trust and responsibility

NNE and Pharmaplan have joined forces to create NNE Pharmaplan, the world's leading engineering and consultancy company focused entirely on the pharma and biotech industries.

Inés Aréizaga Esteva (Spain), 25 years old  
Education: Chemical Engineer

– You have to be proactive and open-minded as a newcomer and make it clear to your colleagues what you are able to cope. The pharmaceutical field is new to me. But busy as they are, most of my colleagues find the time to teach me, and they also trust me. Even though it was a bit hard at first, I can feel over time that I am beginning to be taken seriously and that my contribution is appreciated.



NNE Pharmaplan is the world's leading engineering and consultancy company focused entirely on the pharma and biotech industries. We employ more than 1500 people worldwide and offer global reach and local knowledge along with our all-encompassing list of services.  
[nnepharmaplan.com](http://nnepharmaplan.com)

nne pharmaplan®



**Problem 4.20:** The upright image is virtual. Since the image is *behind* the lens/mirror, a *concave mirror* is inside the black box.

Step 1: Since  $m = h_i/h_o = (5\text{ cm})/(2\text{ cm}) = 2.5 = -d_i/d_o$ , we flip the image about the principal axis and connect it with the object; the intercept with the principal axis is the location of the mirror.

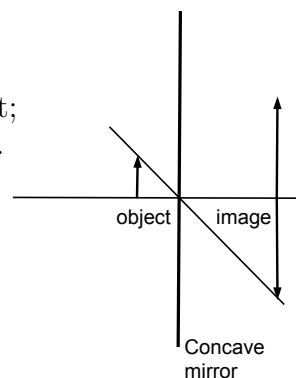

Step 2: We draw the continuation of the reflected ray 2 and find the intercept with the concave mirror. We then connect the intercept with the object; the intercept with the principal axis is the focal point  $F$ . We measure  $f = 3.2\text{ cm}$ .

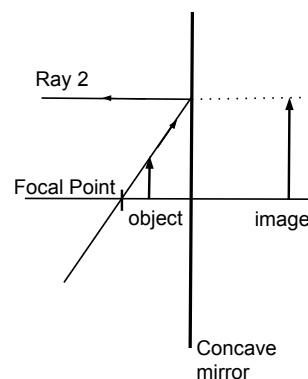

Step 3: We draw the incident ray 1 and find the intercept with the concave mirror. We then connect the intercept with the image as the continuation of reflected ray 1.

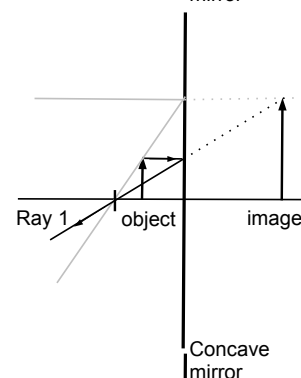

Step 4: We draw ray 3 by connecting the object and the image, and find the intercept with the principal axis: this is the center of the mirror. We measure  $R = 6.5\text{ cm}$ . Thus  $f = R/2$ .

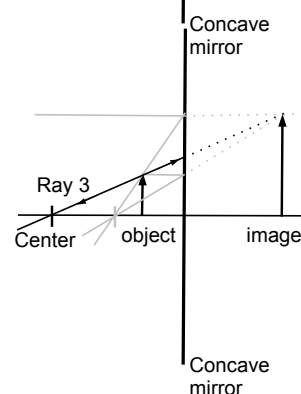

We use the the magnification equation  $m = h_i/h_o$

$$m = \frac{5\text{ cm}}{2.0\text{ cm}} = 2.5,$$

Since  $m = -d_i/d_o$  we find  $d_i = -2.5 d_o$ . The distance between object and image is given by  $\Delta = 8.0\text{ cm} = d_o - d_i$   
 $\Rightarrow d_o - (-2.5 d_o) = 3.5 d_o$  so that

$$d_o = \frac{8.0\text{ cm}}{3.5} = 2.3\text{ cm},$$

and

$$d_i = -5.7\text{ cm}.$$



We now use the mirror equation to find the focal length  $1/f = 1/d_o + 1/d_i$ , or

$$\frac{1}{f} = \frac{1}{2.3 \text{ cm}} + \frac{1}{(-5.7 \text{ cm})} = \frac{1}{3.9 \text{ cm}}.$$

**Problem 4.21:** We calculate the strength of the magnetic field from the strength of the electric field  $B_0 = E_0/c$ , so that

$$B_0 = \frac{750 \text{ V/m}}{3.0 \times 10^8 \text{ m/s}} = 2.5 \times 10^{-6} \text{ T}.$$

We find the rms-value:  $E = E_0/\sqrt{2} = 530.3 \text{ V/m}$ . The energy density follows  $u = \epsilon_0 E^2$ ,

$$u = 8.85 \times 10^{-12} \frac{\text{C}^2}{\text{N m}^2} \cdot \left(530.3 \frac{\text{N}}{\text{C}}\right)^2 = 2.5 \times 10^{-6} \frac{\text{J}}{\text{m}^3}.$$

We then find the intensity  $S = cu$ ,

$$S = 3.0 \times 10^8 \frac{\text{m}}{\text{s}} \cdot 2.5 \times 10^{-6} \frac{\text{J}}{\text{m}^3} = 747 \frac{\text{W}}{\text{m}^2}.$$

The power delivered to the ice cube follows  $P = SA$ ,

$$P = 747 \frac{\text{W}}{\text{m}^2} \cdot 1.0 \times 10^{-4} \text{ m}^2 = 7.47 \times 10^{-2} \text{ W}.$$

The mass of the ice cube is given by  $m = \rho V = 917 \text{ kg/m}^3 \cdot 1.0 \times 10^{-6} \text{ m}^3 = 9.17 \times 10^{-4} \text{ kg}$ . This gives for the necessary heat to melt the ice  $Q = mL$ ,

$$Q = 9.17 \times 10^{-4} \text{ kg} \cdot 33.5 \times 10^4 \frac{\text{J}}{\text{kg}} = 307 \text{ J}.$$

Thus the time necessary to melt the ice follows  $t = Q/P$

$$t = \frac{307 \text{ J}}{7.47 \times 10^{-2} \text{ W}} = 4.1 \times 10^3 \text{ s}.$$

*That's about 1.14 hours!* This is much longer than what is observed if an icecube is left on a kitchen counter; in our calculation we ignore the heat delivered to the icecube by the ambient air.

**Problem 4.22:** The image is virtual so that the object must lie within the focal length:

$$0 < d_o < f = \frac{R}{2} = \frac{14.5 \text{ cm}}{2} = 7.25 \text{ cm}.$$

Since  $d_i < 0$ , we find the distance between object and image  $d_o - d_i = 21 \text{ cm}$  so that  $d_i = d_o - 21 \text{ cm}$ . We drop the units and find  $1/d_o + 1/(d_o - 21) = 1/7.25$ , or

$$7.25 \cdot (2d_o - 21) = d_o^2 - 21d_o$$

or  $d_o^2 - 35.5d_o + 152.25 = 0$ . The roots are

$$d_{o,\pm} = \frac{-(-35.5) \pm \sqrt{(-35.5)^2 - 4 \cdot 152.25}}{2} = \frac{35.5 \pm 26.5}{2} = \begin{cases} 5.0 \\ 31.0 \end{cases}$$

Thus  $d_o = 5.0$  cm and  $d_i = 5.0$  cm  $-$   $21.0$  cm  $= -16.0$  cm. We find the magnification  $m = -d_i/d_o$ ,

$$m = -\frac{(-16.0 \text{ cm})}{5.0 \text{ cm}} = 3.2,$$

so that the image height follows  $h_i = mh_o$ ,

$$h_i = 3.2 \cdot 2.4 \text{ cm} = 7.7 \text{ cm}.$$

This e-book  
*is made with*  
**SetaPDF**



**SETASIGN**

PDF components for PHP developers

[www.setasign.com](http://www.setasign.com)



**Problem 4.23:** We find the distance between lines:  $d = 1 \text{ cm}/8600 = 1.16 \times 10^{-6} \text{ m}$ . We find  $\sin \theta = m\lambda/d$ . For  $\theta = 90^\circ$ , we get  $1 = m\lambda/d$  so that the *shortest* wavelength determines the largest order:

$$m = \frac{d}{\lambda} = \frac{1.16 \times 10^{-6} \text{ m}}{4.0 \times 10^{-7} \text{ m}} = 2.9.$$

We observe two orders. The diffraction angle of the red line in first order is given by

$$\sin \theta_{1,\text{red}} = 1 \cdot \frac{7.0 \times 10^{-7} \text{ m}}{1.16 \times 10^{-6} \text{ m}} = 0.60,$$

so that  $\theta_{1,\text{red}} = 37.1^\circ$ . Similarly for the violet line in second order:

$$\sin \theta_{2,\text{violet}} = 2 \cdot \frac{4.0 \times 10^{-7} \text{ m}}{1.16 \times 10^{-6} \text{ m}} = 0.69,$$

so that  $\theta_{2,\text{violet}} = 59.9^\circ$ . Since  $\theta_{1,\text{red}} < \theta_{2,\text{violet}}$ , the orders do not overlap. We obtain  $1 = m'\lambda_{\text{red}}/d'$  so that  $d' = m'\lambda_{\text{red}}$ , or

$$d' = 4 \cdot 7.0 \times 10^{-7} \text{ m} = 2.8 \times 10^{-6} \text{ cm} = \frac{1 \text{ cm}}{3571}.$$

Thus, the diffraction grating has about 3500 lines per centimeter.

**Problem 4.24:** Harry's farpoint is given by  $D_{\text{far}} = 1.02 \text{ m}$  and the nearpoint is  $D_{\text{near}} = 25.0 \text{ cm}$ . We find the minimum power of the lens in his eyes:

$$P_{\text{min,Harry}} = \frac{1}{1.02 \text{ m}} + \frac{1}{0.018 \text{ m}} = 56.5 \text{ m}^{-1},$$

and the maximum power of the lens in his eyes:

$$P_{\text{max,Harry}} = \frac{1}{0.25 \text{ m}} + \frac{1}{0.018 \text{ m}} = 59.5 \text{ m}^{-1}.$$

For Charlie: farpoint is  $D_{\text{far}} = \infty$  and her nearpoint follows from

$$\frac{1}{D_{\text{near}}} = 1.0 \text{ m}^{-1} - \frac{1}{0.25 \text{ m}} = -3 \text{ m}^{-1},$$

so that

$$D_{\text{near}} = 0.33 \text{ m} + 0.02 \text{ m} = 0.35 \text{ m}.$$

We thus obtain the minimum power of the lens in her eyes:

$$P_{\text{min,Charlie}} = \frac{1}{0.018 \text{ m}} = 55.5 \text{ m}^{-1},$$

and the maximum power of the lens in his eyes:

$$P_{\text{max,Charlie}} = \frac{1}{0.35 \text{ m}} + \frac{1}{0.018 \text{ m}} = 58.4 \text{ m}^{-1}$$

For Harry: The object is farthest away when the image is at the far point:

$$\frac{1}{x_{\text{max}}} + \frac{1}{(-1.0 \text{ m})} = 1.0 \text{ m}^{-1},$$

so that  $x_{\max} = 0.5$  m and the farthest distance is 52.0 cm from the eyes.  
 The object is closest when the image is at the near point:

$$\frac{1}{x_{\min}} + \frac{1}{(-0.23 \text{ m})} = 1.0 \text{ m}^{-1},$$

so that  $x_{\min} = 0.19$  m and the closest object is 21 cm from the eyes.  
 For Charlie: The object is farthest away when the image is at the far point:

$$\frac{1}{x_{\max}} + \frac{1}{\infty} = -1.0 \text{ m}^{-1},$$

so that  $x_{\max} = -1.0$  m. Recall that  $x$  is the distance from the eyeglasses and thus must be positive. We conclude that the farthest distance is *infinitely* far from the eyes.  
 The object is closest when the image is at the near point:

$$\frac{1}{x_{\min}} + \frac{1}{(-0.33 \text{ m})} = -1.0 \text{ m}^{-1},$$

so that  $x_{\min} = 0.25$  m and the closest object is 27 cm from the eyes.

**Problem 4.25:** Since  $\tan \theta = 8.2 \text{ m}/16.5 = 0.5$ , the angle follows  $\theta = 26.4^\circ$ .  
 We obtain the distance traveled on the beach and in the lake:

$$d_{\text{beach}} = \frac{9.3 \text{ m}}{\cos 26.4^\circ} = 10.4 \text{ m}, \quad d_{\text{lake}} = \frac{7.2 \text{ m}}{\cos 26.4^\circ} = 8.0 \text{ m}.$$

We find the times on the beach and in the lake:

$$t_{\text{beach}} = \frac{10.4 \text{ m}}{8.9 \text{ m/s}} = 1.2 \text{ s}, \quad t_{\text{lake}} = \frac{8.0 \text{ m}}{1.25 \text{ m/s}} = 6.4 \text{ s}.$$

Thus the total time  $t_{\text{total}} = t_{\text{beach}} + t_{\text{lake}} = 1.2 \text{ s} + 6.4 \text{ s} = 7.6 \text{ s}$ . The index of refraction follows  $n \sim 1/v$  so that  $\sin \theta_1/v_{\text{run}} = \sin \theta_2/v_{\text{swim}}$ . Since  $v_{\text{run}}/v_{\text{swim}} = (8.9 \text{ m/s})/(1.25 \text{ m/s}) = 7.1$ , we find:

$$\chi = \frac{\sin \theta_1}{\sin \theta_2} = 7.1.$$

We use  $x$  [m] where the lifeguard enters the lake. We find

$$\sin \theta_1 = \frac{x}{\sqrt{9.3^2 + x^2}},$$

$$\sin \theta_2 = \frac{8.2 - x}{\sqrt{7.2^2 + (8.2 - x)^2}}.$$

We thus arrive at the ratio  $\chi(x)$ :

$$\chi(x) = \frac{x}{\sqrt{9.3^2 + x^2}} \cdot \frac{\sqrt{7.2^2 + (8.2 - x)^2}}{8.2 - x}.$$

We evaluate the RHS in *Excel* and solve the (nonlinear) equation numerically. We read off from the graph:

$$x^* = 7.55 \text{ m.}$$

We obtain the distance traveled on the beach:

$$D_{\text{beach}} = \sqrt{(7.55 \text{ m})^2 + (9.3 \text{ m})^2} = 12.0 \text{ m,}$$

and in the lake

$$D_{\text{lake}} = \sqrt{(8.2 \text{ m} - 7.55 \text{ m})^2 + (7.2 \text{ m})^2} = 7.3 \text{ m.}$$

We find the time on the beach:

$$T_{\text{beach}} = \frac{12.0 \text{ m}}{8.9 \text{ m/s}} = 1.3 \text{ s,}$$

and in the lake:

$$T_{\text{lake}} = \frac{7.2 \text{ m}}{1.25 \text{ m/s}} = 5.8 \text{ s.}$$

The total time follows  $T_{\text{total}} = T_{\text{beach}} + T_{\text{lake}}$ ,

$$T_{\text{total}} = 1.3 \text{ s} + 5.8 \text{ s} = 7.1 \text{ s.}$$

**Problem 4.26:** The wavelength in air is  $\lambda_{\text{air}} = v_{\text{air}}/f = (343 \text{ m/s})/(41 \times 10^3 \text{ s}^{-1}) = 8.37 \text{ mm}$ . The condition for *destructive* interference is  $d_2 - d_1 = \lambda/2 = 4.2 \text{ mm}$  so that for  $d_2 = 4.64 \text{ cm}$ ,  $x = \sqrt{d_2^2 - d_1^2}$ ,

$$x = \sqrt{(4.64 \text{ cm})^2 - (4.2 \text{ cm})^2} = 2.0 \text{ cm.}$$

We find the times  $t = d/v_{\text{air}}$ :

$$t_1 = \frac{0.042 \text{ m}}{343 \text{ m/s}} = 0.122 \text{ ms}, \quad t_2 = \frac{0.0464 \text{ m}}{343 \text{ m/s}} = 0.135 \text{ ms.}$$

23 find the time delay  $\Delta t = t_2 - t_1 = 0.013 \text{ ms}$ . We compare with the period  $T = 1/f$ ,

$$T = \frac{1}{41,000 \text{ Hz}} = 0.024 \text{ ms.}$$

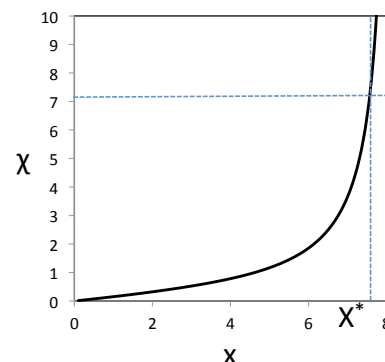

We now consider when the water-filled vial is placed between #1 and the microphone. The time  $t_2 = 0.135$  ms is unchanged. For #1:

$$t'_1 = \frac{0.042 \text{ cm} - 0.0165 \text{ m}}{343 \text{ m/s}} + \frac{0.0165 \text{ m}}{1497 \text{ m/s}} = 0.085 \text{ ms}.$$

We find the time delay between the arrival of the ultrasound pulses from #1 and #2,  $\Delta t' = t_2 - t'_1$ ,

$$\Delta t' = 0.135 \text{ ms} - 0.085 \text{ ms} = 0.050 \text{ ms}.$$

We find  $\Delta t' = 2T$  so that we now have *constructive* interference at the location of the microphone.

**Problem 4.27:** The intensity is determined by the energy density:  $S = cu$ . Since  $1 \text{ cm}^2 = 10^{-4} \text{ m}^2$ , we find  $u = S/c$ ,

$$u = \frac{250 \text{ W/m}^2}{3.0 \times 10^8 \text{ m/s}} = 8.3 \times 10^{-7} \frac{\text{J}}{\text{m}^3}.$$

The energy density is determined by the electric field:  $u = \epsilon_0 E^2$  so that  $E = \sqrt{u/\epsilon_0}$

$$E = \sqrt{\frac{8.3 \times 10^{-7} \text{ J/m}^3}{8.85 \times 10^{-12} \text{ C}^2/(\text{N m}^2)}} = 306.2 \frac{\text{N}}{\text{C}}.$$

The radius of the spot is  $A = \pi a^2 = \pi(2.4 \times 10^{-3} \text{ m})^2 = 1.81 \times 10^{-5} \text{ m}^2$ . Thus the power is given by  $P = SA$ , or

$$P = 250 \frac{\text{W}}{\text{m}^2} \cdot 1.81 \times 10^{-5} \text{ m}^2 = 4.5 \text{ mW}.$$

The energy [“heat”] follows  $Q = P \cdot \Delta t$

$$Q = 4.5 \times 10^{-3} \text{ W} \cdot 7.5 \times 10^{-2} \text{ s} = 3.4 \times 10^{-4} \text{ J}.$$

**Problem 4.28:** We find the drawing. Both lenses are *converging*. The focal length of lens 1 is  $f_1 = 14/9 \text{ cm} = 1.6 \text{ cm}$  and for lens 2:  $f_2 = 110/44 \text{ cm} = 2.25 \text{ cm}$ . The distance between the two lenses is  $D = (115/21) \text{ cm} = 5.8 \text{ cm}$ . The object distance is  $d_o = (14/3) \text{ cm} = 4.67 \text{ cm}$  and the (final) image distance is  $d'_i = 7.4 \text{ cm}$ . When we move the object to the left, we find  $d_{o,2} = 4.6 \text{ cm} + 1.0 \text{ cm} = 5.6 \text{ cm}$  so that

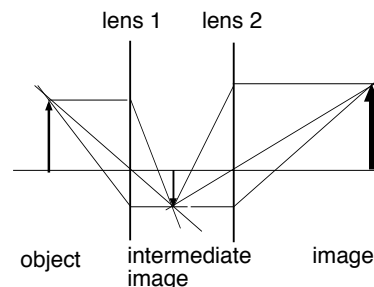

$$\frac{1}{d_i} = \frac{1}{1.6 \text{ cm}} - \frac{1}{5.6 \text{ cm}} = \frac{1}{2.2 \text{ cm}},$$

so that the image distance follows  $d_{i,1} = 2.2 \text{ cm}$ . It follows that the object distance of the intermediate image is  $d'_{o,2} = 5.8 \text{ cm} - 2.2 \text{ cm} = 3.6 \text{ cm}$ . The image produced by lens 2 follows:

$$\frac{1}{d_{i,2}} = \frac{1}{2.4 \text{ cm}} - \frac{1}{3.6 \text{ cm}} = \frac{1}{7.2 \text{ cm}},$$

so that the image distance of lens #2 follows  $d'_{i,2} = 7.2 \text{ cm}$ . We find the positions along the principal axis with  $x_{\text{object}} = 0$  [*my choice!*]

$$\begin{aligned} x_{\text{intermediate}} &= 5.6 \text{ cm} + 2.2 \text{ cm} = 7.8 \text{ cm}, \\ x_{\text{image}} &= 5.6 \text{ cm} + 5.8 \text{ cm} + 7.2 \text{ cm} = 18.6 \text{ cm}. \end{aligned}$$

**Problem 4.29:** We find the focal length of the concave mirror  $f = +R/2 = 6.0 \text{ cm}$ . The object distance is  $d_o = 8.5 \text{ cm}$ , we use the lens equation:  $1/d_i = 1/f - 1/d_o$ ,

$$\frac{1}{d_i} = \frac{1}{6.0 \text{ cm}} - \frac{1}{8.5 \text{ cm}} = \frac{1}{20.4 \text{ cm}},$$

so that the image distance for the concave mirror follows  $d_i = +20.4 \text{ cm}$ . We find the magnification:  $m = -d_i/d_o = -20.4 \text{ cm}/8.5 \text{ cm} = -2.4$ , so that the image height follows  $h_i = m \cdot h_o$

$$h_i = (-2.4) \cdot 3.0 \text{ cm} = -7.2 \text{ cm}, \quad (\text{concave}).$$

We repeat for the hemisphere turned around. The focal length of the convex mirror  $f = -R/2 = -6.0 \text{ cm}$ . The object distance stays the same,  $d_o = 8.5 \text{ cm}$ , so that the lens equation yields  $1/d_i = 1/f - 1/d_o$ ,

$$\frac{1}{d_i} = \frac{1}{(-6.0 \text{ cm})} - \frac{1}{8.5 \text{ cm}} = -\frac{1}{3.5 \text{ cm}} \quad (\text{convex}),$$

so that the image distance follows  $d_i = -3.5 \text{ cm}$ . We now find the magnification:  $m = -d_i/d_o = -(-3.5 \text{ cm})/8.5 \text{ cm} = +0.41$  so that the image height yields  $h_i = m \cdot h_o$ ,

$$h_i = (+0.41) \cdot 3.0 \text{ cm} = 1.24 \text{ cm}, \quad (\text{convex}).$$

We generalize for the second object at an unknown distance from the hemisphere. We find the magnifications  $m_{\text{concave}} = -7m_{\text{convex}}$ . We find the ratio of the image distances  $d_{\text{concave}}$  and  $d_{\text{convex}}$ :  $d_{\text{concave}}/d_o = -7d_{\text{convex}}/d_o$ , so that

$$d_{\text{convex}} = -\frac{1}{7} d_{\text{concave}}.$$

We now use the mirror equation twice. Since  $f = \pm R/2$ , we find the condition:

$$\frac{1}{d_o} = \frac{2}{R} - \frac{1}{d_{\text{concave}}} = -\frac{2}{R} + \frac{7}{d_{\text{concave}}},$$

We find the image distance for the concave mirror:

$$d_{\text{concave}} = 2R = 24.0 \text{ cm}.$$

The object distance is thus given by

$$\frac{1}{d_o} = \frac{1}{6.0 \text{ cm}} - \frac{1}{24.0 \text{ cm}} = \frac{1}{8.0 \text{ cm}},$$

so that  $d_o = 8.0 \text{ cm}$ . We thus find the magnification  $m_{\text{concave}} = -(24.0 \text{ cm})/(8.0 \text{ cm}) = -3.0$ . Since  $m_{\text{concave}} = h_{\text{concave}}/h_o$ , we find the object height  $h_o = h_{\text{concave}}/m_{\text{concave}}$ ,

$$h_o = \frac{-7 \text{ cm}}{-3} = +2.3 \text{ cm}.$$

Note that the object height must be positive - objects are (always!) *upright*.

**Problem 4.30:** We start from the resolving power:

$$\theta = 1.22 \frac{\lambda}{D} = 1.22 \frac{5.5 \times 10^{-7} \text{ m}}{10 \text{ m}} = 6.7 \times 10^{-8}.$$

The distance between observer [the telescope on Mauna Kea] and the object [on the Moon] matters. We find  $\Delta = 3.84 \times 10^8 \text{ m}$ . We use  $\theta \simeq H/\Delta$ , we find  $H = \Delta \cdot \theta$ ,

$$H = 3.84 \times 10^8 \text{ m} \cdot 6.7 \times 10^{-8} = 26.3 \text{ m}.$$

We can thus see objects on the Moon that are greater than 26.3 m, of about 90 ft.

*Note:* Two telescopes can be linked ‘interferometrically,’ the resolving power is much greater since the “effective” diameter is approximately the distance between the telescopes.

**Problem 4.31:** Since  $f = c/\lambda$ , the frequencies follow

$$f_0 = \frac{3.0 \times 10^8 \text{ m/s}}{656 \times 10^{-9} \text{ m}} = 4.573 \times 10^{14} \text{ Hz}.$$

and

$$f = \frac{3.0 \times 10^8 \text{ m/s}}{660 \times 10^{-9} \text{ m}} = 4.545 \times 10^{14} \text{ Hz}.$$



We find the frequency if the observer is stationary:  $f = f_0/(1 \pm v_s/c)$ , where  $+/-$  if the source (star) is moving away/towards from observer (Earth). Since  $f < f_0$ , it follows that the star is moving *away* from the Earth. We find  $v/c = f_0/f - 1$ ,

$$\frac{v}{c} = \frac{4.573 \times 10^{14} \text{ Hz}}{4.545 \times 10^{14} \text{ Hz}} - 1 = 6.16 \times 10^{-3},$$

this gives for the speed of the star:

$$v = 6.16 \times 10^{-3} \cdot 3.0 \times 10^8 \frac{\text{m}}{\text{s}} = 1.85 \times 10^6 \frac{\text{m}}{\text{s}},$$

or  $v = 1850 \text{ km/s}$ .

*Note:* This is a typical for the speed of a galaxy in the *Virgo-cluster* and reflects the expansion of the universe.

**Problem 4.32:** The diffraction angle follows from the geometry of the rooms  $\tan \theta = (4.2 \text{ m}/2)/(3.8 \text{ m})$  so that  $\theta = 29^\circ$ . Since  $\tan \theta = \lambda/D$ , where  $D = 1.2 \text{ m}$ , the shortest wavelength follows  $\lambda_{\min} = D \sin \theta$ ,

$$\lambda_{\min} = 1.2 \text{ m} \cdot 0.48 = 0.58 \text{ m}.$$

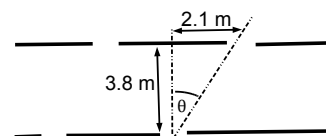

The range of wavelength follows

$$0.658 \text{ m} < \lambda < \infty.$$

Since  $f = v/\lambda$ , we can hear frequencies that are smaller than a cutoff:

$$f_{\max} = \frac{v}{\lambda_{\min}} = \frac{343 \text{ m/s}}{0.58 \text{ m}} = 589.6 \text{ Hz}.$$

We can thus hear frequencies  $0 < f < 589.6 \text{ Hz}$ , or the tones  $A_3, C_4, D_4, G_4, A_4$ , and  $C_5$  [and perhaps  $D_5$ ]. We obtain the upper bound of the frequency  $f'_{\max} \simeq 350 \text{ Hz}$  [ $< 220 \text{ Hz}$ ]. Thus, we obtain the lower bound of the wavelength:  $\lambda'_{\min} = v/f'_{\max}$ ,

$$\lambda'_{\min} = \frac{343 \text{ m}}{350 \text{ Hz}} \simeq 1.0 \text{ m}.$$

We find the new diffraction angle:  $\sin \theta' = \lambda'/D = 1.0 \text{ m}/1.2 \text{ m} = 0.83$  so that  $\theta' = 56.0^\circ$ . We change the size of the room  $L'$ . We find  $\tan \theta' = 1.5 = (L'/2)/3.8 \text{ m}$

$$L' = 2 \cdot 1.5 \cdot 3.8 \text{ m} = 11.4 \text{ m}.$$

*Note:* As an additional benefit, we get bigger rooms!

**Problem 4.33:** We find the speed of the surface waves inside the bucket:  $v = \sqrt{gd}$ ,

$$v = \sqrt{9.8 \frac{\text{m}}{\text{s}^2} \cdot 0.24 \text{ m}} = 1.53 \frac{\text{m}}{\text{s}}.$$

The diameter of the bucket determines the wavelength:

$$D = \lambda/2 \text{ so that } \lambda = 2D$$

$$\lambda = 2 \cdot 0.54 \text{ m} = 1.08 \text{ m}.$$

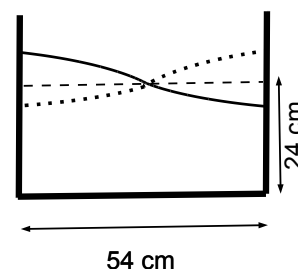

We find the frequency  $f = v/\lambda$ ,

$$f = \frac{1.53 \text{ m/s}}{1.08 \text{ m}} = 1.42 \text{ Hz.}$$

The frequency of the surface water waves is the frequency of Harry's leg movement while walking. The period follows  $T = 1/f$ ,

$$T = \frac{1}{1.42 \text{ Hz}} = 0.70 \text{ s.}$$

We assume  $L = 0.8 \text{ m}$  for the stride length of Harry. The speed of walking is determined by the stride length and the period:  $v_{\text{walking}} = L/T$ ,

$$v_{\text{walking}} = \frac{0.8 \text{ m}}{0.70 \text{ s}} = 1.1 \frac{\text{m}}{\text{s}}.$$

*Note:* Our solution makes the assumption that the water wave is linear, which requires that the amplitude of the standing wave is much smaller than the depth of water. This phenomena is called *sloshes* and is a problem for tanker trucks and railroads. In lakes, it is called *seiches*. The term was promoted by the Swiss hydrologist F.-A. Forel in 1890, who was first to make scientific observations of the effect in Lake Geneva.

"I studied English for 16 years but...  
...I finally learned to speak it in just six lessons"  
Jane, Chinese architect

ENGLISH OUT THERE

Click to hear me talking before and after my unique course download



**Problem 4.34:** Since the object is infinitely far away  $d_{o,1} = \infty$ , the image produced by the first lens is at the focal point  $d_{i,1} = f_1 = 4.0$  cm. We find the distance of the intermediate image to the second lens  $d_{o,2} = 6$  cm. We use the lens equation  $1/d_{i,2} = 1/f_2 - 1/d_{o,2}$

$$\frac{1}{d_{i,2}} = \frac{1}{7.0 \text{ cm}} - \frac{1}{6.0 \text{ cm}} = -\frac{1}{42 \text{ cm}}.$$

or  $d_{o,2} = -42$  cm. Since image distance produced by the second lens is negative,  $d_{o,2} < 0$ , the image is *virtual*. Since  $d_{o,1} = \infty$ , we obtain  $d_{i,1} = f_1 = 4.0$  cm. We find the object distance for the second lens  $d_{o,2} = 8$  cm. We use the lens equation to find the image distance  $1/d_{i,2} = 1/f_2 - 1/d_{o,2}$ ,

$$\frac{1}{d_{i,2}} = \frac{1}{7.0 \text{ cm}} - \frac{1}{8.0 \text{ cm}} = \frac{1}{56 \text{ cm}},$$

or  $d_{o,2} = 56$  cm. Since  $d_{o,2} > 0$ , the image is *real*.

We find the total magnification from the object and image heights,  $m = h_i/h_o = f_2/f_1$ ,

$$m = \frac{f_2}{f_1} = \frac{7.0 \text{ cm}}{4.0 \text{ cm}} = 1.75.$$

The image is *virtual* and is infinitely far away. Since  $f_2/f_1 = 3.5$ , we find  $f_2 = 3.5f_1$  so that

$$12 \text{ cm} = f_1 + f_2 = f_1 + 3.5f_1 = 4.5f_1$$

We find the focal length of lens #1:

$$f_1 = \frac{12.0 \text{ cm}}{4.5} = 2.7 \text{ cm},$$

so that  $f_2 = 12 \text{ cm} - 2.7 \text{ cm} = 9.3 \text{ cm}$ .

*Note:* Opera glasses are useful because the distance between the two lenses does not have to be adjusted as is the case for binoculars.

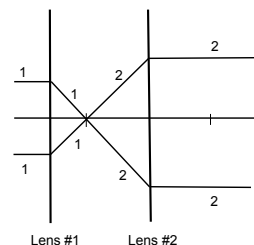

**Problem 4.35:** The lens is under tension when the object is at the nearpoint:  $1/d_o = 1/f - 1/d_i$ ,

$$\frac{1}{d_o} = 52.5 \text{ m}^{-1} - 47.6 \text{ m}^{-1} = \frac{1}{20.5 \text{ cm}},$$

so that Harry's nearpoint is 20.5-cm from his eyes. The lens is relaxed when the object is at the farpoint:  $1/d_o = 1/f - 1/d_i$

$$\frac{1}{d_o} = 48.5 \text{ m}^{-1} - 47.6 \text{ m}^{-1} = \frac{1}{110 \text{ cm}},$$

so that Harry's farpoint is 1.1-m from his eyes. Since normal vision corresponds to a farpoint at *infinity*, we conclude that Harry is nearsighted (*myopic*).

He needs glasses to see objects far away so that  $d_o = \infty$ , and  $d_i = -(1.10 \text{ m} - 0.02 \text{ m}) = -1.08 \text{ m}$ . We find the power of the correction eye glasses  $1/f_{\text{glasses}} = 1/d_o + 1/d_i$ ,

$$\frac{1}{f_{\text{glasses}}} = -\frac{1}{1.08 \text{ m}} = -0.93 \text{ diopters}.$$

When the object is at the intermediate point, we have to solve a two-lens problem. The object distance is  $d_o = 50.1 \text{ cm} - 2.1 \text{ cm} = 47.9 \text{ cm}$  so that the distance of the image formed by his eyeglasses:  $1/d_i = 1/f - 1/d_o$ ,

$$\frac{1}{d_i} = -0.93 \text{ m}^{-1} - \frac{1}{0.479 \text{ m}} = -\frac{1}{0.33 \text{ m}}.$$

We find  $d_i = -33.1 \text{ cm}$ : This is the intermediate image; it is 35.1 cm away from his eyes,  $d'_o = 35.1 \text{ cm}$ . Since the image is formed on the retina, the image distance is  $d'_i = 2.1 \text{ cm}$  so that the power of the lens in the eyes follow  $1/f = 1/d'_o + 1/d'_i$ ,

$$\frac{1}{f} = \frac{1}{0.351 \text{ m}} + \frac{1}{0.021 \text{ m}} = +50.4 \text{ diopters}.$$

Note that  $48.5 \text{ diopters} < 1/f < 52.5 \text{ diopters}$ , *as it should*.

**Problem 4.36:** The tension in the rope is determined by the weight of the block:  $T = Mg = 3.7 \text{ kg} \cdot 9.8 \text{ m/s}^2 = 36.3 \text{ N}$ . The mass per unit length is  $m/l = 5.7 \times 10^{-2} \text{ kg}/2.1 \text{ m} = 2.7 \times 10^{-2} \text{ kg/m}$ . We find the wave speed:  $v = \sqrt{T/(m/L)}$ ,

$$v = \sqrt{\frac{36.3 \text{ N}}{2.7 \times 10^{-2} \text{ kg/m}}} = 36.6 \frac{\text{m}}{\text{s}}.$$

The time for the pulse to reach the top follows  $t = L/v$ ,

$$t = \frac{2.1 \text{ m}}{36.6 \text{ m/s}} = 5.7 \times 10^{-2} \text{ s}.$$

When the block is immersed in water, the the speed follows  $v' = L/t'$ ,

$$v' = \frac{2.1 \text{ m}}{6.1 \times 10^{-2} \text{ s}} = 34.4 \frac{\text{m}}{\text{s}}.$$

Since the mass per unit length of the string does not change, we find  $T' = v'^2(m/L)$ ,

$$T' = \left(34.4 \frac{\text{m}}{\text{s}}\right)^2 \cdot 2.7 \times 10^{-2} \frac{\text{kg}}{\text{m}} = 32.0 \text{ N}.$$

The difference in the tension is due to the buoyant force:  $F_B = T - T' = 36.3 \text{ N} - 32.0 \text{ N} = 4.3 \text{ N}$ . Since  $F_B = M_{\text{water}}g$ , we find  $M_{\text{water}} = 4.3 \text{ N}/(9.8 \text{ m/s}^2) = 0.44 \text{ kg}$ . We thus get for the volume of the hanging mass:  $V = M/\rho_{\text{water}}$ ,

$$V = \frac{0.44 \text{ kg}}{1000 \text{ kg/m}^3} = 4.4 \times 10^{-4} \text{ m}^3$$

so that the (average) density of the hanging mass follows  $\rho = M/V$ ,

$$\rho = \frac{3.7 \text{ kg}}{4.4 \times 10^{-4} \text{ m}^3} = 8.4 \times 10^3 \frac{\text{kg}}{\text{m}^3}.$$

**Problem 4.37:** Initially, the the ball moves away from the stationary observer and the frequency drop. The frequency undergoes a jump when the ball hits the ground. The observed frequency is higher than 440 Hz while the ball approaches the top of well.

We find the maximum speed of the ball when it hits the ground:

$v_{\max} = \sqrt{2 \cdot 9.8 \text{ m/s}^2 \cdot 17.3 \text{ m}} = 18.4 \text{ m/s}$ . Since the source [ball] is moving we find the lowest and highest frequency:

$$f_{\max,\min} = 440 \text{ Hz} \frac{1}{1 \pm (18.4 \text{ m/s})/(343 \text{ m/s})},$$

so that the minimum frequency is  $f_{\min} = 417.6 \text{ Hz}$  and the maximum frequency is  $f_{\max} = 464.9 \text{ Hz}$ . Since  $f' > f_{\text{device}}$ , the device approaches the observer, i.e., the ball travels upwards. We find  $450 \text{ Hz} = 440 \text{ Hz}/(1 - v'/v)$ , and solve for the ratio  $v'/v = 1 - f_{\text{device}}/f'$ ,

$$\frac{v'}{v} = 1 - \frac{440 \text{ Hz}}{450 \text{ Hz}} = 0.022,$$

The speed follows  $v' = 0.022 \cdot 343 \text{ m/s} = 7.5 \text{ m/s}$ . The time to hit the ground  $t_1 = \sqrt{2 \cdot 17.4 \text{ m}/(9.8 \text{ m/s}^2)} = 1.88 \text{ s}$ . Time to rebound  $t_2 = (18.4 \text{ m/s} - 7.5 \text{ m/s})/(9.8 \text{ m/s}^2) = 1.11 \text{ s}$  so that  $t' = t_1 + t_2$ ,

$$t' = 1.88 \text{ s} + 1.11 \text{ s} = 2.99 \text{ s}.$$

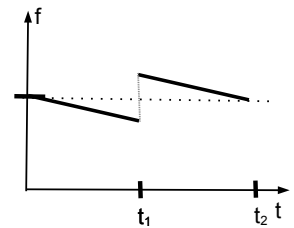



## Sharp Minds - Bright Ideas!

Employees at FOSS Analytical A/S are living proof of the company value - First - using new inventions to make dedicated solutions for our customers. With sharp minds and cross functional teamwork, we constantly strive to develop new unique products - Would you like to join our team?

FOSS works diligently with innovation and development as basis for its growth. It is reflected in the fact that more than 200 of the 1200 employees in FOSS work with Research & Development in Scandinavia and USA. Engineers at FOSS work in production, development and marketing, within a wide range of different fields, i.e. Chemistry, Electronics, Mechanics, Software, Optics, Microbiology, Chemometrics.

**We offer**  
A challenging job in an international and innovative company that is leading in its field. You will get the opportunity to work with the most advanced technology together with highly skilled colleagues.

Read more about FOSS at [www.foss.dk](http://www.foss.dk) - or go directly to our student site [www.foss.dk/sharpminds](http://www.foss.dk/sharpminds) where you can learn more about your possibilities of working together with us on projects, your thesis etc.

The Family owned FOSS group is the world leader as supplier of dedicated, high-tech analytical solutions which measure and control the quality and production of agricultural, food, pharmaceutical and chemical products. Main activities are initiated from Denmark, Sweden and USA with headquarters domiciled in Hillerød, DK. The products are marketed globally by 23 sales companies and an extensive net of distributors. In line with the corevalue to be 'First', the company intends to expand its market position.



Dedicated Analytical Solutions

FOSS  
Slangerupgade 69  
3400 Hillerød  
Tel. +45 70103370  
[www.foss.dk](http://www.foss.dk)



**Problem 4.38:** The surface wave is diffracted at the opening. The first three boats are within the zeroth-order maximum:

$$\tan \theta = \frac{8.0 \text{ m}/2}{20.0 \text{ m} - 3 \cdot 2.2 \text{ m}} = 0.3,$$

so that the diffraction angle follows  $\theta = 16.6^\circ$ . Since  $\sin \theta = \lambda/D$ , the wavelength follows  $\lambda = D \sin \theta$ ,

$$\lambda = 2.5 \text{ m} \cdot \sin 16.6^\circ = 0.72 \text{ m}.$$

The frequency is  $f = 1/(0.4 \text{ s}) = 2.5 \text{ Hz}$ . The wave speed then follows from  $v = f\lambda$ ,

$$v = 0.72 \text{ m} \cdot 2.5 \text{ s}^{-1} = 1.8 \frac{\text{m}}{\text{s}}.$$

*Note:* The speed of surface waves depends on the depth  $d$  of the water:  $v = \sqrt{gd}$ . Thus, the speed  $v = 1.8 \text{ m/s}$  corresponds to a depth  $d = v^2/g = (1.8 \text{ m})^2/(9.8 \text{ m/s}^2) = 0.33 \text{ m}$ .

We find the smallest diffraction angle:

$$\tan \theta_{\min} = \frac{8.0 \text{ m}/2}{20.0 \text{ m} - 7 \cdot 2.2 \text{ m}} = 0.87,$$

and the angle follows  $\theta_{\min} = 41.0^\circ$ . Since  $\sin \theta_{\min} = \lambda_{\min}/D$ , we get for the *shortest* wavelength,  $\lambda_{\min} = D \sin \theta$ ,

$$\lambda_{\min} = 2.5 \text{ m} \sin 41.0^\circ = 1.64 \text{ m}.$$

Since long wavelengths correspond to low frequencies, we have the condition  $f < f_{\max} = v/\lambda_{\min} = (1.8 \text{ m/s})/(1.64 \text{ m}) = 1.1 \text{ Hz}$ . Since  $T = 1/f$ , the possible period of the oscillatory motion follow  $T > T_{\min} = 1/f_{\max}$

$$T > \frac{1}{1.1 \text{ Hz}} = 0.9 \text{ s}.$$

**Problem 4.39:** The focal point is 4.0 cm behind the mirror. We draw lines parallel to the principal axis at the heights  $h_o = 5.0 \text{ cm}$  and  $h_i = 2.0 \text{ cm}$ . The incoming ray 1 is parallel to the principal axis at the height  $h_o$ . It is reflected by the mirror such that the reflected ray passes through the focal point:

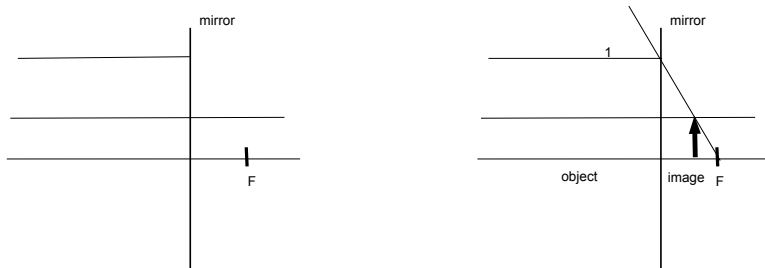

We read off from the figure  $d_i \simeq -2.4$  cm. We find the magnification from the object and image heights,  $m = h_i/h_o = (2.0 \text{ cm})/(5.0 \text{ cm}) = 0.4 = -d_i/d_o$  so that the object distance follows  $d_o = -d_i/0.4 = -5d_i/2$ . We find the focal length from the lens equation,  $1/f = 1/d_o + 1/d_i$ ,

$$\frac{1}{(-4.0 \text{ cm})} = -\frac{2}{5d_i} + \frac{1}{d_i} = \frac{3}{5d_i},$$

so that the image distance follows

$$d_i = \frac{3}{5} \cdot (-4.0 \text{ cm}) = -2.4 \text{ cm}.$$

The reflected ray 2 is parallel to the principal axis at the height  $h_i = 2.0$  cm. The continuation of the incoming ray 2 goes through the focal point:

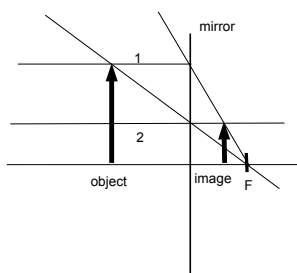

We read off from the figure  $d_o \simeq +6.0$  cm. The image distance follows from the object distance  $d_i = -2d_o/5$ . The lens equation yields  $1/f = 1/d_o + 1/d_i$  yields,

$$\frac{1}{(-4.0 \text{ cm})} = \frac{1}{d_o} + \left(-\frac{5}{2d_o}\right) = -\frac{3}{2d_o},$$

and

$$d_o = -\frac{3}{2} \cdot (-4.0 \text{ cm}) = +6.0 \text{ cm}.$$

**Problem 4.40:** The object is at infinity  $d_o = \infty$ . Thus  $1/f = 1/d_o + 1/d_i$

$$d_i = f.$$

We get

$$d_i = \frac{1}{(-2.5 \text{ m}^{-1})} = -0.40 \text{ m} = -40 \text{ cm} \quad (\text{Harry}),$$

$$d_i = \frac{1}{(-1.75 \text{ m}^{-1})} = -0.57 \text{ m} = -57 \text{ cm} \quad (\text{Emmy}).$$

That is, the farpoints are 42 cm and 59 cm away from their pupils. The image is formed at the farpoints.

In the case when Harry wears Emmy's glasses:  $1/d_o = 1/f - 1/d_i$

$$\frac{1}{d_o} = -1.75 \text{ m}^{-1} - \frac{1}{(-0.4 \text{ m})} = 0.75 \text{ m}^{-1},$$

so that  $d_o = 1.33$  m. That is, Harry can clearly see objects that are 1.35 away from his eyes. In the case when Emmy wears Harry's eyeglasses:  $1/d_o = 1/f - 1/d_i$ ,

$$\frac{1}{d_o} = -2.5 \text{ m}^{-1} - \frac{1}{(-0.57 \text{ m})} = -0.75 \text{ m}^{-1},$$

so that  $d_o$  is not defined. Note that the object distance cannot be negative. To see what is going on, assume that the object is far away, so that  $d_o = \infty$ . When Emmy wears Harry's eyeglasses:  $d_i = f_{\text{Harry}}$

$$d_i = -40 \text{ cm}.$$

That is, the image is 42 cm away from her eyes. Since this is closer than her farpoint (59 cm), Emmy can see objects clearly, even if objects are infinitely far away. In fact, her nearsightedness is over-corrected, i.e., her vision is better than 20/20.

**gaieteye**  
Challenge the way we run

**EXPERIENCE THE POWER OF  
FULL ENGAGEMENT...**

**RUN FASTER.  
RUN LONGER..  
RUN EASIER...**

**READ MORE & PRE-ORDER TODAY  
WWW.GAITEYE.COM**



**Problem 5.1:** Electron and positron are particle- antiparticle pairs and thus have the same mass and rest energies:  $E_e = E_p = mc^2$ ,

$$E = 9.11 \times 10^{-31} \text{ kg} \cdot \left(3.0 \times 10^8 \frac{\text{m}}{\text{s}}\right)^2 = 8.2 \times 10^{-14} \text{ J} = 0.511 \text{ MeV}.$$

Thus, the energy of the incident photon is  $E_\gamma = E_e + E_p = 1.04 \text{ MeV}$  so that the frequency is  $E_\gamma = hf$ . The frequency follows  $f = E_\gamma/h$ ,

$$f = \frac{2 \cdot 8.2 \times 10^{-14} \text{ J}}{6.62 \times 10^{-34} \text{ Js}} = 2.5 \times 10^{20} \text{ Hz}.$$

Since  $E = pc$ , the momentum of the photon is given by  $p_\gamma = E/c$ ,

$$p_\gamma = \frac{2 \cdot 8.2 \times 10^{-14} \text{ J}}{3.0 \times 10^8 \text{ m/s}} = 5.5 \times 10^{-22} \frac{\text{kg m}}{\text{s}}.$$

The carbon mass is given by  $M = 12 \cdot 1.66 \times 10^{-27} \text{ kg} = 2.0 \times 10^{-26} \text{ kg}$ . The total momentum of the carbon-photon system is conserved during the ‘collision’ (and equal to zero, conservation of linear momentum,  $p_C + P_\gamma = 0$  then yields the velocity of the carbon atom  $v_C = p_\gamma/M_C$ ,

$$v_C = \frac{5.5 \times 10^{-22} \text{ kg m/s}}{2.0 \times 10^{-26} \text{ kg}} = 2.75 \times 10^4 \frac{\text{m}}{\text{s}}.$$

**Problem 5.2:** We use  $L = 6 \cdot 1.39 \times 10^{-10} \text{ m} = 8.34 \times 10^{-10} \text{ m}$ . Because the electron is in the “first harmonic,” the wavelength follows from  $L = \lambda/2$  so that  $\lambda = 1.67 \times 10^{-9} \text{ m}$ . We find the momentum  $p = h/\lambda$

$$p = \frac{6.63 \times 10^{-34} \text{ Js}}{1.67 \times 10^{-9} \text{ m}} = 4.0 \times 10^{-25} \frac{\text{kg m}}{\text{s}}.$$

The kinetic energy of the electron follows:  $E = \text{KE} = p^2/2m$

$$E = \frac{(4.0 \times 10^{-25} \text{ kg m/s})^2}{2 \cdot 9.11 \times 10^{-34} \text{ kg}} = 8.78 \times 10^{-20} \text{ J} = 0.548 \text{ eV}.$$

We find the energy levels  $E_n = E_1 n^2$  so that for  $n = 2$ :  $E_2 = 2.19 \text{ eV}$ . The photon energy follows from the energy difference between states  $n = 2$  and  $n = 1$ :  $E_\gamma = E_2 - E_1$

$$E_\gamma = 2.19 \text{ eV} - 0.55 \text{ eV} = 1.64 \text{ eV}.$$

Since  $E_\gamma = hc/\lambda$ , the wavelength of the photon follows:  $\lambda = hc/E_\gamma$ ,

$$\lambda = \frac{6.62 \times 10^{-34} \text{ Js} \cdot 3.0 \times 10^8 \text{ m/s}}{1.64 \cdot 1.602 \times 10^{-19} \text{ J}} = 755 \text{ nm}.$$

This is just outside the visible part of the spectrum in the *near-infrared*.

**Problem 5.3:** The neutrons are in thermal equilibrium so that the energy is determined by the temperature  $E = k_B T/2$ ,

$$E = \frac{1}{2} 1.38 \times 10^{-23} \frac{\text{J}}{\text{K}} \cdot 1200 \text{ K} = 8.28 \times 10^{-21} \text{ J} = 0.052 \text{ eV}.$$

We write the kinetic energy  $\text{KE} = mv^2/2 = p^2/2m$  so that the momentum follows  $p = \sqrt{2mE}$ ,

$$p = \sqrt{2 \cdot 1.67 \times 10^{-27} \text{ kg} \cdot 8.28 \times 10^{-21} \text{ J}} = 5.26 \times 10^{-24} \frac{\text{kg m}}{\text{s}}.$$

We find the wavelength of the neutron:  $\lambda = h/p$

$$\lambda = \frac{6.62 \times 10^{-34} \text{ Js}}{5.26 \times 10^{-24} \text{ kg m/s}} = 0.126 \text{ nm}.$$

The neutrons are diffracted at the opening. We find the diffraction angle:  $\sin \theta = \lambda/2b$

$$\sin \theta = \frac{0.126 \text{ nm}}{2 \cdot 0.361 \text{ nm}} = 0.175,$$

so that the spread of neutrons follows  $\theta = 10.0^\circ$

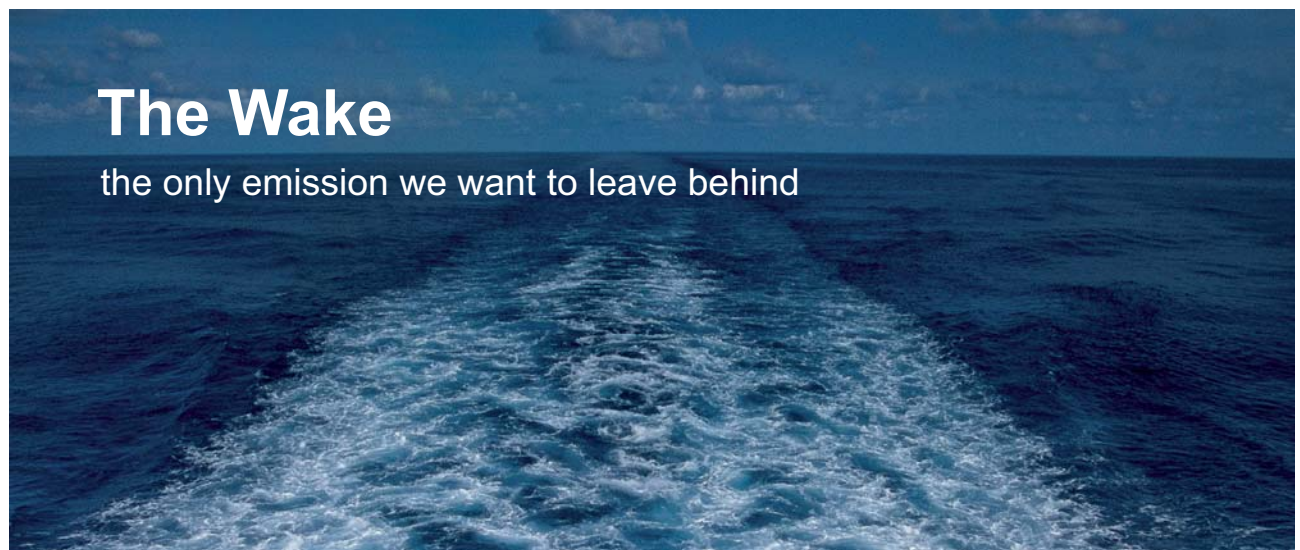

# The Wake

the only emission we want to leave behind

Low-speed Engines Medium-speed Engines Turbochargers Propellers Propulsion Packages PrimeServ

The design of eco-friendly marine power and propulsion solutions is crucial for MAN Diesel & Turbo. Power competencies are offered with the world's largest engine programme – having outputs spanning from 450 to 87,220 kW per engine. Get up front! Find out more at [www.mandieselturbo.com](http://www.mandieselturbo.com)

Engineering the Future – since 1758.

## MAN Diesel & Turbo



**Problem 5.4:** We find the work function from the minimum frequency:  $\Phi = E_{\min} = hf_{\min}$ . Since the minimum is determined by the maximum wavelength  $f_{\min} = c/\lambda_{\max}$ , we find  $\Phi = hc/\lambda_{\max}$ ,

$$\Phi = \frac{6.62 \times 10^{-34} \text{ Js} \cdot 3.0 \times 10^8 \text{ m/s}}{5.4 \times 10^{-7} \text{ m}} = 3.7 \times 10^{-19} \text{ J} = 2.3 \text{ eV}.$$

We use the shortest wavelength:  $\lambda_{\min} = 380 \text{ nm}$  so that  $E_{\gamma} = hc/\lambda_{\min}$ ,

$$E_{\gamma} = \frac{6.62 \times 10^{-34} \text{ Js} \cdot 3.0 \times 10^8 \text{ m/s}}{3.8 \times 10^{-7} \text{ m}} = 3.7 \times 10^{-19} \text{ J} = 3.3 \text{ eV}.$$

Thus, the kinetic energy of the electron follows,  $E_e = E_{\gamma} - \Phi$ ,

$$E_e = 3.3 \text{ eV} - 2.3 \text{ eV} = 1.0 \text{ eV} = 1.609 \times 10^{-19} \text{ J}.$$

Since  $E_e = mv^2/2$ , we find the speed of the electron:  $v_e = \sqrt{2E_e/m}$ ,

$$v_e = \sqrt{\frac{2 \cdot 1.602 \times 10^{-19} \text{ J}}{9.11 \times 10^{-31} \text{ kg}}} = 5.9 \times 10^5 \frac{\text{m}}{\text{s}}.$$

**Problem 5.5:** We calculate the number of moles in 0.5 kg of plutonium:

$$n = \frac{500 \text{ g}}{244 \text{ g}} = 2.05.$$

We then find the total number of plutonium nuclei:  $N = nN_A$ , where  $N_A$  is Avogadro number,

$$N = 2.05 \cdot 6.02 \times 10^{23} = 1.23 \times 10^{24}.$$

We express the half-life in units of seconds,  $T_{1/2} = 24,360 \text{ yrs} = 7.69 \times 10^{11}$ , and the decay rate follows

$$\lambda = \frac{\ln 2}{T_{1/2}} = 9.02 \times 10^{-13} \text{ s}^{-1}.$$

The initial activity follows  $A_0 = \lambda N$ ,

$$A_0 = 9.02 \times 10^{-13} \text{ s}^{-1} \cdot 1.23 \times 10^{24} = 1.1 \times 10^{12} \text{ Bq}.$$

The activity decays exponentially in time  $A/A_0 = \exp(-\lambda t)$ , We write the decay rate in terms of the half-life  $1/\lambda = T_{1/2}/\ln 2$ , and find the time  $t = -(T_{1/2}/\ln 2) \ln (A/A_0)$ ,

$$t = -\frac{24,360 \text{ yrs}}{\ln 2} \ln \left( \frac{5.0 \times 10^5 \text{ Bq}}{1.1 \times 10^{12} \text{ Bq}} \right) \simeq 243,500 \text{ yrs}.$$

**Problem 5.6:** The frequency of the light follows  $f = c/\lambda$ ,

$$f = \frac{3.00 \times 10^8 \text{ m/s}}{9.54 \times 10^{-8} \text{ m}} = 3.14 \times 10^{15} \text{ Hz},$$

so that the energy of the photon is given by  $E_\gamma = hf$ ,

$$E_\gamma = 6.62 \times 10^{-34} \text{ Js} \cdot 3.14 \times 10^{15} \text{ Hz} = 2.08 \times 10^{-18} \text{ J} = 13.0 \text{ eV}.$$

The energy of the electrons has discrete levels,  $E_n = h^2 n^2 / (8ma^2)$  so that the energy of the photon is determined by the change of the electron energy:  $E_\gamma = E_5 - E_2$

$$E_\gamma = \frac{h^2}{8ma^2} (5^2 - 2^2) = \frac{21h^2}{8ma^2}.$$

We solve for the length of the box:  $a^2 = 21h^2 / 8mE_\gamma$

$$a^2 = \frac{21 \cdot (6.62 \times 10^{-34} \text{ Js})^2}{8 \cdot 9.11 \times 10^{-31} \text{ kg} \cdot 2.08 \times 10^{-18} \text{ J}} = 6.08 \times 10^{-19} \text{ m}^2$$

and  $a = 0.78 \text{ nm}$ . Thus we find the number of C = C bonds:

$$N_{\text{bond}} = \frac{0.78 \text{ nm}}{0.154 \text{ nm}} = 5.$$

We now examine the effect of vibrations. The length of the box is increased and decreased. We obtain  $a_l = 1.05a$  and  $a_s = 0.95a$ . Since  $E_n \sim 1/a^2$ , we obtain the photon energies corresponding

$$E_l = \frac{E_\gamma}{(1.05)^2} = 1.9 \times 10^{-18} \text{ J},$$

$$E_s = \frac{E_\gamma}{(0.95)^2} = 2.3 \times 10^{-18} \text{ J}.$$

For the longer bond, we obtain the corresponding frequency

$$f_l = \frac{1.9 \times 10^{-18} \text{ J}}{6.62 \times 10^{-34} \text{ Js}} = 2.9 \times 10^{15} \text{ Hz},$$

and wavelength

$$\lambda_l = \frac{3.0 \times 10^8 \text{ m/s}}{2.9 \times 10^{15} \text{ s}^{-1}} = 103 \text{ nm}.$$

For the shorter bond, we find the frequency

$$f_s = \frac{2.3 \times 10^{-18} \text{ J}}{6.62 \times 10^{-34} \text{ Js}} = 3.5 \times 10^{15} \text{ Hz},$$

and wavelength

$$\lambda_s = \frac{3.0 \times 10^8 \text{ m/s}}{3.5 \times 10^{15} \text{ s}^{-1}} = 86 \text{ nm}.$$

*Note:* The frequencies (wavelengths)  $f_s$  ( $\lambda_s$ ) and  $f_l$  ( $\lambda_l$ ) correspond to the *Stokes* and *anti-Stokes* lines of the  $n_i = 5$  to  $n_f = 2$  transition.

**Problem 5.7:** The temperature follows  $T = (273 + 37) \text{ K} = 310 \text{ K}$  and the energy:  $E_\gamma = k_B T$ ,

$$E_\gamma = 1.38 \times 10^{-23} \frac{\text{J}}{\text{K}} \cdot 310 \text{ K} = 4.28 \times 10^{-21} \text{ J}.$$

The frequency follows  $f = E_\gamma/h$

$$f = \frac{4.28 \times 10^{-21} \text{ J}}{6.63 \times 10^{-34} \text{ Js}} = 6.5 \times 10^{12} \text{ Hz},$$

and the wavelength  $\lambda = c/f$

$$\lambda = \frac{3.0 \times 10^8 \text{ m/s}}{6.45 \times 10^{12} \text{ s}^{-1}} = 4.6 \times 10^{-5} \text{ m}.$$

This corresponds to *infrared* radiation. *Night vision scopes and goggles* are based on the emission of infrared radiation by animals (and humans). For microwave, the frequency follows  $f = c/\lambda$

$$f = \frac{3.0 \times 10^8 \text{ m/s}}{5.3 \times 10^{-3} \text{ m}} = 5.7 \times 10^{10} \text{ Hz},$$

We find the energy of the photon:  $E_\gamma = hf$

$$E_\gamma = 6.63 \times 10^{-34} \text{ Js} \cdot 5.7 \times 10^{10} \text{ Hz} = 3.7 \times 10^{-23} \text{ J},$$

so that the temperature follows  $T = E_\gamma/k_B$

$$T = \frac{3.7 \times 10^{-23} \text{ J}}{1.38 \times 10^{-23} \text{ J/K}} = 2.74 \text{ K}.$$

*Note:* In 1964, Penzias and Wilson observed this type of radiation with their radiotelescope in Holmdel, NJ, while working at AT&T Laboratories. They first thought the signal was “noise” from radiostations in nearby NYC. However, the radiation is observed in all directions; Robert Dicke [from Princeton] then explained that the radiation originates from the universe [“cosmic background radiation”]. Penzias and Wilson [together with Kapitsa] were awarded the Nobel prize in physics in 1978.

**Problem 5.8:** We calculate the kinetic energy from the absolute temperature:  $\text{KE} = 3k_B T/2$ ,

$$\text{KE} = \frac{3}{2} \cdot 1.38 \times 10^{-23} \frac{\text{J}}{\text{K}} \cdot 300 \text{ K} = 6.21 \times 10^{-21} \text{ J}.$$

Since  $\text{KE} = mv^2/2$ , we find the speed  $v = \sqrt{2\text{KE}/m}$ ,

$$v = \sqrt{\frac{2 \cdot 6.21 \times 10^{-21} \text{ J}}{1.67 \times 10^{-27} \text{ kg}}} = 2.73 \times 10^3 \frac{\text{m}}{\text{s}}.$$

The momentum of the neutron follows  $p = mv$ ,

$$p = 1.67 \times 10^{-27} \text{ kg} \cdot 2.73 \times 10^3 \frac{\text{m}}{\text{s}} = 4.55 \times 10^{-24} \frac{\text{kg m}}{\text{s}}.$$

The momentum of the neutron follows  $p = mv$ ,

$$p = 1.67 \times 10^{-27} \text{ kg} \cdot 2.73 \times 10^3 \frac{\text{m}}{\text{s}} = 4.55 \times 10^{-24} \frac{\text{kg m}}{\text{s}}.$$

The deBroglie wavelength of thermal neutrons is given by  $\lambda = h/p$ ,

$$\lambda = \frac{6.63 \times 10^{-34} \text{ Js}}{4.55 \times 10^{-24} \text{ kg m/s}} = 1.45 \times 10^{-10} \text{ m} = 0.145 \text{ nm}.$$

We find the momentum of the scattered neutron:  $p' = h/\lambda'$

$$p' = \frac{6.63 \times 10^{-34} \text{ Js}}{1.65 \times 10^{-10} \text{ m}} = 4.02 \times 10^{-24} \frac{\text{kg m}}{\text{s}}.$$

The speed of the scattered neutron follows  $v' = p'/m$

$$v' = \frac{4.02 \times 10^{-24} \text{ kg m/s}}{1.67 \times 10^{-27} \text{ kg}} = 2.41 \times 10^3 \frac{\text{m}}{\text{s}}.$$

The kinetic energy of the scattered neutron follows  $\text{KE}' = mv'^2/2$

$$\text{KE}' = \frac{1.67 \times 10^{-27} \text{ kg}}{2} \cdot \left(2.41 \times 10^3 \frac{\text{m}}{\text{s}}\right)^2 = 4.85 \times 10^{-21} \text{ J}.$$

The change in the kinetic energy of the neutron is equal to the transferred energy,  $\Delta E = \text{KE} - \text{KE}' = 6.21 \times 10^{-21} \text{ J} - 4.85 \times 10^{-21} \text{ J} = 1.36 \times 10^{-21} \text{ J} = 8.5 \text{ meV}$ . This energy transfer is consistent with vibrational excitations of macromolecules.

I joined MITAS because  
I wanted **real responsibility**

The Graduate Programme  
for Engineers and Geoscientists  
[www.discovermitas.com](http://www.discovermitas.com)



Real work  
International opportunities  
Three work placements



**Month 16**  
I was a construction  
supervisor in  
the North Sea  
advising and  
helping foremen  
solve problems





**Problem 5.9:** We find the decay constant  $\lambda = \ln 2/T_{1/2}$

$$\lambda = \frac{\ln 2}{5730 \text{ yr}} = 1.21 \times 10^{-4} \text{ yr}^{-1}.$$

The activity decays exponentially with time:  $A = A_0 \exp(-\lambda t)$ . We find the expected activity if the sample was produced 2000 years ago:

$$A = A_0 \exp(-1.21 \times 10^{-4} \text{ yr}^{-1} \cdot 2000 \text{ yr}) = 0.23 \text{ Bq} \cdot 0.785 = 0.18 \text{ Bq}.$$

This activity is less than the observed activity  $A < A' = 0.21 \text{ Bq}$ . We write  $A'/A_0 = \exp(-\lambda t)$  and take the (natural) logarithm on both sides:  $t = -(1/\lambda) \ln(A'/A_0)$ ,

$$t' = -\frac{5730 \text{ yrs}}{\ln 2} \cdot \ln\left(\frac{0.21 \text{ Bq}}{0.23 \text{ Bq}}\right) \simeq 750 \text{ yr}.$$

Thus  $t' < t$  so that the shroud is about as old as the first historical evidence of its existence. The shroud is inconsistent with the period in which Jesus lived. The significance of the shroud remains controversial to this day.

**Problem 5.10:** The smallest electron wavelength determines the largest momentum:

$$p_{\max} = h/\lambda_{\min},$$

$$p_{\max} = \frac{6.62 \times 10^{-34} \text{ Js}}{2 \cdot 0.361 \times 10^{-9} \text{ m}} = 9.2 \times 10^{-25} \frac{\text{kg m}}{\text{s}}.$$

Since  $p = mv$ , we find the maximum speed of electron:  $v = p/m$ , so that

$$v = \frac{9.2 \times 10^{-25} \text{ kg m/s}}{9.1 \times 10^{-31} \text{ kg}} = 1.0 \times 10^6 \frac{\text{m}}{\text{s}}.$$

The actual value is  $v_{\text{Fermi}} = 1.57 \times 10^6 \text{ m/s}$ . Since the electron is “free,” the electron has only kinetic energy. We find the kinetic energy:  $E = \text{KE} = mv^2/2$ .

$$E = \frac{1}{2} 9.1 \times 10^{-31} \text{ kg} \cdot \left(1.0 \times 10^6 \frac{\text{m}}{\text{s}}\right)^2 = 4.5 \times 10^{-19} \text{ J} = 2.8 \text{ eV}.$$

(the actual value of the Fermi energy is  $E_{\text{Fermi}} = 2.67 \text{ eV}$ .) We use  $E = k_B T$ , to find the temperature  $T = E/k_B$ :

$$T = \frac{4.5 \times 10^{-19} \text{ J}}{1.38 \times 10^{-23} \text{ J/K}} = 3.3 \times 10^4 \text{ K}.$$

(The actual value of the Fermi temperature is  $T_{\text{Fermi}} = 8.2 \times 10^4 \text{ K}$ ).

**Problem 5.11:** The frequency of a light is  $f = c/\lambda = 3.0 \times 10^8 \text{ ms}^{-1}/3.2 \times 10^{-7} \text{ m} = 9.4 \times 10^{14} \text{ Hz}$ . The energy of a photon follows  $E = hf$ ,

$$E = 6.6 \times 10^{-34} \text{ Js} \cdot 9.4 \times 10^{14} \text{ s}^{-1} = 6.2 \times 10^{-19} \text{ J}.$$

Since  $E = pc$  for massless particles, the momentum of the photon follows  $p = E/c$

$$p = \frac{6.2 \times 10^{-19} \text{ J}}{3.0 \times 10^8 \text{ m/s}} = 2.1 \times 10^{-27} \frac{\text{kg m}}{\text{s}}.$$

We now calculate the number of photons per area and per time. The area of the skin cell is  $A = (5.0 \times 10^{-6} \text{ m})^2 = 2.5 \times 10^{-11} \text{ m}^2$ . The energy from radiation during the interval  $t = 1,800 \text{ s}$  (30 min) is given by  $E_{\text{tot}} = S A t$ ,

$$E_{\text{tot}} = 0.9 \frac{\text{W}}{\text{m}^2} \cdot 2.5 \times 10^{-11} \text{ m}^2 \cdot 1,800 \text{ s} = 4.1 \times 10^{-8} \text{ J}.$$

The number of photons follows  $N_\gamma = E_{\text{tot}}/E$

$$N_\gamma = \frac{4.1 \times 10^{-8} \text{ J}}{6.2 \times 10^{-19} \text{ J}} = 6.5 \times 10^{10}.$$

**Problem 5.12:** We find the wavelength of the photon from Balmer rule:  $1/\lambda = R(1/n^2 - 1/m^2)$ , with  $R = 1.097 \times 10^7 \text{ m}^{-1}$  and  $n = 2$  and  $m = 4$  so that

$$\frac{1}{\lambda} = 1.097 \times 10^7 \text{ m}^{-1} \left( \frac{1}{4} - \frac{1}{16} \right),$$

so that  $\lambda = 486 \text{ nm}$ . We find the momentum of the photon:  $p = h/\lambda$ ,

$$p_\gamma = \frac{6.6 \times 10^{-34} \text{ J s}}{4.86 \times 10^{-7} \text{ m}} = 1.35 \times 10^{-27} \frac{\text{kg m}}{\text{s}}.$$

The momentum of the recoil hydrogen atom follows from the law of conservation of momentum:  $0 = p_\gamma + p_{\text{H}}$  so that  $|p_{\text{H}}| = p_\gamma$ . Since  $|p_{\text{H}}| = m_{\text{H}}v_{\text{r}}$  [with  $m_{\text{H}} = 1 \text{ u}$ ], we for the recoil speed of the hydrogen atom:  $v_{\text{H}} = |p_{\text{H}}|/m$

$$v_{\text{H}} = \frac{1.35 \times 10^{-27} \text{ kg m/s}}{1.66 \times 10^{-27} \text{ kg}} = 0.81 \frac{\text{m}}{\text{s}}.$$



**Problem 5.13:** Since  $E_{\max} = 0.9 \text{ eV} = 1.44 \times 10^{-19} \text{ J}$ . We use the mass-energy equivalence principle  $E = mc^2$ , we find the upper limit of the mass in units kg:  $m_{\max} = E_{\max}/c^2$ ,

$$m_{\max} = \frac{1.44 \times 10^{-19} \text{ J}}{(3.0 \times 10^8 \text{ m/s})^2} = 1.6 \times 10^{-36} \text{ kg}.$$

The number of neutrinos  $\mathcal{N}$  through the area  $A = 1.0 \text{ m}^2$  per one-second time interval  $\Delta t = 1 \text{ s}$ , is determined by the number density and the speed of light,  $\mathcal{N}/\Delta t = c \cdot (n/V)$ . The number density of neutrinos follows  $n/V = (\mathcal{A}/\Delta t)/c$ ,

$$\frac{n}{V} = \frac{3 \times 10^6 \times 10^9 \text{ m}^2 \text{ s}^{-1}}{3.0 \times 10^8 \text{ m/s}} = 1 \times 10^7 \text{ m}^{-3}.$$

We find the upper limit for the mass density of neutrinos:  $\rho_{\max} = m_{\max} \cdot (n/V)$ :

$$\rho_{\max} = 1.6 \times 10^{-36} \text{ kg} \cdot 1 \times 10^7 \text{ m}^{-3} = 1.6 \times 10^{-29} \frac{\text{kg}}{\text{m}^3}.$$

**Problem 5.14:** Since the density of water is  $\rho = 1,000 \text{ kg/m}^3$ , the tank contains the mass  $m = 80.0 \times 10^{-3} \text{ m}^3 \cdot 1.0 \times 10^3 \text{ kg/m}^3 = 80.0 \text{ kg}$ . The absorbed is  $E = Dm$ . We set this energy equal to the heat necessary to raise the temperature of the water:  $Q = mc\Delta T$ . We find  $Dm = mc\Delta T$ , so that the mass “drops out” and we obtain  $D = c\Delta T$ , or  $\Delta T = D/c$

$$\Delta T = \frac{80 \text{ J/kg}}{4186 \text{ J/(kg} \cdot ^\circ \text{C)}} = 0.02^\circ \text{C}.$$

*Comment:* This calculation shows that the total energy deposited is insignificant. The biological damage caused by ionizing radiation is explained by detailed mechanisms of the interaction of ionizing radiation with (biological) matter (e.g., DNA damage).

**Problem 5.15:** We use the mass-energy  $E = mc^2$  principle to tabulate the energy in “checkbook” style:

Item	Expense	Deposit
proton		938.26 Mev
neutron		939.55 Mev
deuteron	-1875.59 Mev	
Balance		2.22 Mev

Thus, the energy of the constituents [proton and neutron] is greater than the energy of deuteron. The difference is the binding energy of a deuteron is 2.22 MeV.

**Problem 5.16:** We set  $EPE_{\text{self}} = m_e c^2$  so that  $ke^2/a = m_e c^2$  so that the classical electron radius is given by  $a = ke^2/m_e c^2$ . We insert the constant and numerical values to find

$$a = \frac{8.99 \times 10^9 \text{ N/(C}^2 \text{m}^2) \cdot (1.602 \times 10^{-19} \text{ C})^2}{9.11 \times 10^{-31} \text{ kg} \cdot (3.0 \times 10^8 \text{ m/s})^2} = 2.81 \times 10^{-15} \text{ m}$$

that is, the classical electron radius is of the order of femtometer. For comparison, the semi-empirical for the size of an atomic nucleus is given by  $r_n = 1.25 \times 10^{-15} \text{ m} \cdot A^{1/3}$ . We set the electron radius  $a$  equal to the wavelength of the photon  $\lambda = a$ . Compton wavelength of the electron is given by  $\lambda_c = h/m_e c = 2.43 \times 10^{-12} \text{ m}$ . Thus, the Compton wavelength of the electron is much larger than the classical electron radius

$$\frac{\lambda_c}{a} = \frac{2.43 \times 10^{-12} \text{ m}}{2.81 \times 10^{-15} \text{ m}} = 864.$$

The corresponding energies of the photon follow from  $E = hc/\lambda$  so that

$$E_{\gamma, \text{self}} = \frac{6.62 \times 10^{-34} \text{ J s} \cdot 3.0 \times 10^8 \text{ m/s}}{2.81 \times 10^{-15} \text{ m}} = 7.1 \times 10^{-8} \text{ J} = 441 \text{ GeV}$$

$$E_{\gamma, c} = \frac{6.62 \times 10^{-34} \text{ J s} \cdot 3.0 \times 10^8 \text{ m/s}}{2.43 \times 10^{-12} \text{ m}} = 8.2 \times 10^{-14} \text{ J} = 0.51 \text{ GeV}.$$

*Note:* The Compton energy is generally considered the cutoff when quantum field theory becomes important. The classical electron radius enters many equations in quantum field theory, such as the *Klein-Nishina* formula that describes the differential cross section of photons scattered from a free electron.

**Problem 5.17:** The resolving power is determined by the size of the specimen and the distance to the lens:

$$1.22 \frac{\lambda}{D} = \frac{2.0 \times 10^{-9} \text{ m}}{5.0 \times 10^{-2} \text{ m}} = 4 \times 10^{-8}$$

Given the aperture of the lens  $D = 2.0 \times 10^{-3} \text{ m}$ , we solve for the wavelength

$$\lambda = \frac{1}{1.22} 4.0 \times 10^{-3} \text{ m} \cdot 4.0 \times 10^{-9} = 0.13 \text{ nm}.$$

We assume electromagnetic wave, and find the frequency of light:  $f = c/\lambda$

$$f = \frac{3.0 \times 10^8 \text{ m/s}}{1.3 \times 10^{-10} \text{ m}} = 2.3 \times 10^{18} \text{ Hz}.$$

This frequency falls within the *X-ray* part of the spectrum. We find the energy of the photon:  $E_\gamma = hf$ ,

$$E_\gamma = 6.63 \times 10^{-34} \text{ J s} \cdot 2.3 \times 10^{18} \text{ s}^{-1} = 1.5 \times 10^{-15} \text{ J} = 9.4 \text{ keV}.$$

We now assume electron “waves.” Since  $p = mv = h/\lambda$ , we find the speed of the electron:  $v = h/m\lambda$ ,

$$v = \frac{6.67 \times 10^{-34} \text{ J s}}{9.11 \times 10^{-31} \text{ kg} \cdot 1.3 \times 10^{-10} \text{ m}} = 5.6 \times 10^6 \frac{\text{m}}{\text{s}}$$

That’s about 2% of the speed of light. We find the kinetic energy of the electron:  $\text{KE} = mv^2/2$ ,

$$\text{KE} = \frac{1}{2} 9.11 \times 10^{-31} \text{ kg} \cdot \left(5.6 \times 10^6 \frac{\text{m}}{\text{s}}\right)^2 = 1.4 \times 10^{-17} \text{ J} = 89 \text{ eV}.$$

Thus, the potential difference  $\Delta V = 89 \text{ V}$  is used to accelerate the electrons.

**Problem 5.18:** The definition of kayser suggests that  $\lambda = 1.0 \text{ cm} = 1.0 \times 10^{-2} \text{ m}$ . Since  $c = f\lambda$ , the frequency follows  $f = c/\lambda$ ,

$$f = \frac{3.0 \times 10^8 \text{ m/s}}{1.0 \times 10^{-2} \text{ m}} = 3.0 \times 10^{10} \text{ Hz.}$$

For the infrared band, we obtain  $1/\lambda_{\text{IR}} = 1595 \text{ cm}^{-1}$  so that the wavelength follows

$$\lambda_{\text{IR}} = \frac{1}{1595} 10^{-2} \text{ m} = 6.3 \mu\text{m.}$$

The infrared part of the electromagnetic corresponds to wavevelenths  $0.7 \mu\text{m} < \lambda < 1000 \mu\text{m}$ . We find the frequency

$$f_{\text{IR}} = 1595 \times 10^{-2} \text{ m}^{-1} \cdot 3.0 \times 10^{10} \text{ Hz} = 48 \text{ THz}$$

The infrared part of the electromagnetic corresponds to frequencies  $300 \text{ GHz} < f < 430 \text{ THz}$ . We find the energy of the photon  $E_{\text{IR}} = hf_{\text{IR}}$ ,

$$E_{\text{IR}} = 6.62 \times 10^{-34} \text{ J s} \cdot 4.8 \times 10^{13} \text{ Hz} = 3.2 \times 10^{-20} \text{ J} = 0.2 \text{ eV.}$$

The infrared part of the electromagnetic corresponds to energies  $1.2 \text{ meV} < E < 1.7 \text{ eV}$ . That is, this particular infrared band of  $\text{H}_2\text{O}$  vapor is very close to the visible part of the electromagnetic spectrum (i.e., nearinfrared). We compare to thermal energies, and set  $E_{\text{IR}} = k_B T$  and find the temperature:  $T_{\text{IR}} = (3.2 \times 10^{-20} \text{ J}) / (1.38 \times 10^{-23} \text{ J/K}) = 2300 \text{ K}$ .

www.job.oticon.dk

oticon  
PEOPLE FIRST



**Problem 5.19:** We find the frequency of the photon from  $\lambda f = c$  so that  $f = c/\lambda$ ,

$$f = \frac{3.0 \times 10^8 \text{ m/s}}{5.89 \times 10^{-7} \text{ m}} = 5.09 \times 10^{14} \text{ Hz},$$

so that the energy of the photon follows  $E_\gamma = hf$ ,

$$E_\gamma = 6.62 \times 10^{-34} \text{ Js} \cdot 5.09 \times 10^{14} \text{ Hz} = 3.37 \times 10^{-19} \text{ J}.$$

We set  $E_\gamma = m_\gamma c^2$  and find the effective inertial mass of the photon:  $m_\gamma = E_\gamma/c^2$ ,

$$m_\gamma = \frac{3.37 \times 10^{-19} \text{ J}}{(3.0 \times 10^8 \text{ m/s})^2} = 3.75 \times 10^{-36} \text{ kg}.$$

The conservation of energy yields  $E_{\gamma, \text{bottom}} = E_{\gamma, \text{top}} + m_\gamma gh$  so that

$$E_{\gamma, \text{bottom}} - E_{\gamma, \text{top}} = 3.75 \times 10^{-36} \text{ kg} \cdot 9.8 \frac{\text{m}}{\text{s}^2} \cdot 541 \text{ m} = 2.0 \times 10^{-32} \text{ J}.$$

Note that  $E_{\gamma, \text{top}} < E_{\gamma, \text{bottom}}$ , the frequency of the photon on top of Freedom Tower is less than the frequency at ground level. Since the frequency *decreases*, the wavelength *increases*: we say the photon is *red-shifted*. Since  $E_\gamma = hf$ , the frequency shift follows  $\Delta f = \Delta E_\gamma/h$ ,

$$\Delta f = \frac{2.0 \times 10^{-32} \text{ J}}{6.67 \times 10^{-34} \text{ Js}} = 30.0 \text{ Hz}.$$

The fractional change of the frequency thus follows:

$$\frac{\Delta f}{f} = \frac{30.0 \text{ Hz}}{5.1 \times 10^{14} \text{ Hz}} \simeq 6 \times 10^{-14}.$$

*Note:* While this is a small fractional change of the frequency (or wavelength), this effect has been observed [Pound and Rebka, Nobel prize (1952)]; the actual experiment was carried out in the Jefferson laboratory at Harvard University; the height was only 22 m and the corresponding frequency shift  $\Delta f/f \simeq 10^{-15}$ .

**Problem 5.20:** The wavelength of the phonon is  $\lambda = 20a = 20 \cdot 3.61 \times 10^{-10} \text{ m} = 7.22 \times 10^{-9} \text{ m}$ . The momentum of the phonon follows  $p = h/\lambda$ ,

$$p = \frac{6.62 \times 10^{-34} \text{ Js}}{7.22 \times 10^{-9} \text{ m}} = 9.15 \times 10^{-26} \frac{\text{kg m}}{\text{s}}.$$

The frequency of the phonon is given by  $f = c/\lambda$ , where  $c$  is the speed of sound. We obtain

$$f = \frac{4800 \text{ m/s}}{7.22 \times 10^{-9} \text{ m}} = 6.65 \times 10^{11} \text{ Hz}.$$

The energy of the phonon follows  $E = hf$ ,

$$E = 6.62 \times 10^{-34} \text{ Js} \cdot 6.65 \times 10^{11} \text{ Hz} = 4.4 \times 10^{-22} \text{ J}.$$

We set  $E = kT_{\text{phonon}}$  and solve for the temperature of the phonon:  $T_{\text{phonon}} = E/k_B$ ,

$$T_{\text{phonon}} = \frac{4.4 \times 10^{-22} \text{ J}}{1.38 \times 10^{-23} \text{ J/K}} = 32 \text{ K}.$$

*Note:* Since room temperature  $T_{\text{room}} = 300 \text{ K}$  is approximately ten times higher than the characteristic temperature  $T_{\text{room}} \simeq 10 T_{\text{phonon}}$ , scattering of electrons by phonons is very important at temperatures much below room temperature.