

PLANT PHYSIOLOGY and BIOCHEMISTRY

GROWTH AND DEVELOPMENT

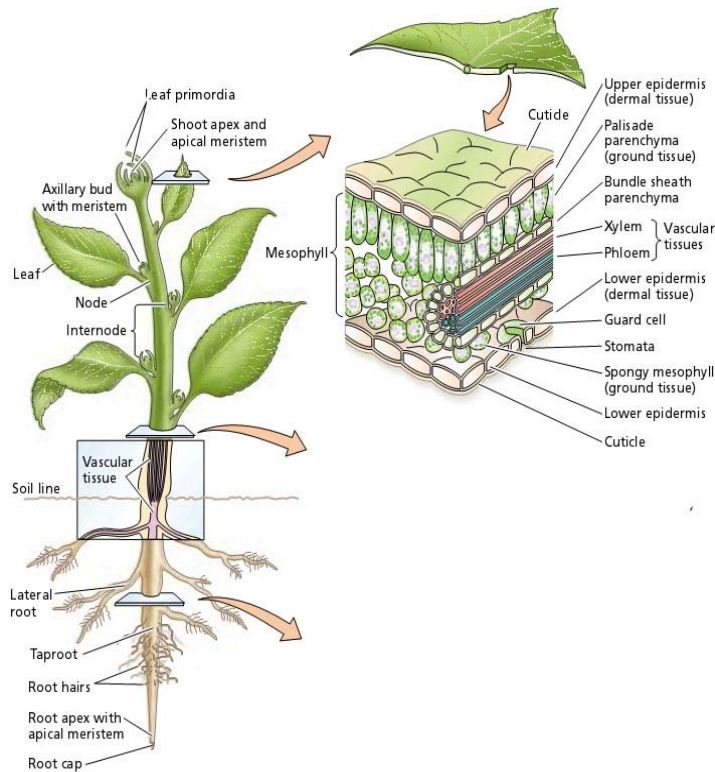

Narpat Singh Shekhawat
Gaurav Sablok
Biotechnology Unit,
Department of Botany,
Jai Narain Vyas University,
Jodhpur- 342 005
Rajasthan

Information about Sources of Figures incorporated in the chapter entitle “Plant Physiology and Biochemistry” in the Book Growth and Development

Figures numbering

- 2,3,4,5,6,7,8,10,11,13,15,16,17,18,19,21,22,25,26,27,29,30,31,32,33,34,35,36,37,38,39,40,41 and 42 from the online version of the book entitled:- **Plant Physiology, 3rd edition** By *Lincoln Taiz and Eduardo Zeiger* Sinauer Associates ISBN: 0878938230 2002. The link is:<http://rapidshare.com/files/4616387/plantphys.rar> Password: **www.AvaxHome.ru**
- 9 and 12 from Jiao et.al, Nature Reviews Genetics Volume 8 (March), 2007.
- 14 and 20 from Baurle and Dean Cell 125, May 19, 2006.
- 23 (A) Gillaspay et.al, The Plant Cell, Vol 5 1993.
- 23(B) from Giovannoni The Plant Cell, Vol 16 (S) 2004.
- 24 from Barry and Giovannoni Journal of Plant Growth Regulator (2007) 26:143–159.
- 28 from Paciorek and Friml, Journal of Cell Science Vol 1199 (7) 2006.

And

- 43 and 44 from Clouse SD (September 30, 2002) Brassinosteroids. In CR Somerville, EM Meyerowitz, eds, The Arabidopsis Book. American Society of Plant Biologists, Rockville, MD, doi: 10.1199/tab.0009, www.aspb.org/publications/arabidopsis/.

We all know that plants are important in economical, environmental and ecological terms. Plus, plants are pleasant to look at, fun to grow, and intellectually interesting (**Poethig, 2001**). In his book, **Eloge de La Plante Francis Halle (1999)** stated if all the animals suddenly disappear from the world, the plants will probably survive, while the converse is not true. The plants produce the oxygen we breathe, the food we eat, fuel/energy we need as citizen of modern world, fiber for cloths we wear, wood/timber for the houses/furniture. Plants remove CO₂ and other polluting agents from our atmosphere. Over thousands of years they have helped us to shape our cultures and societies. Some plants have been seen as to valuable that they have actually changed the course of human history. Without the plants, there would be no human history or prehistory at all.

Botanical knowledge enhances our understanding and appreciation of our world and improves the quality of many people's lives. Mendel discovered the basic laws of genetics with peas (not bees). The first cloning from a differentiated somatic cell involved tobacco (not Dolly). The first recognized gaseous hormone was not nitrous oxide but ethylene. The first discovered morphogen was not retinoic acid but cytokinin. Catalytic RNA (now ribozyme) was first suggested in "Viroids" attacking Avocado plant. Transposable elements were discovered in corn before Bacteria/yeast and fruit fly.

Palaeohistory and origin of plants and animals (The origin of plants and animals – the last common plant/Animal ancestor):

It is now accepted that all modern eukaryotes evolved from a mitochondria-bearing ancestors. Sometimes after the appearance of the first eukaryotes, but before the last common ancestor of animals and plants, the uptake of the alpha – proteobacterium like organisms led to acquiring of mitochondria. After the last common ancestors of animals and plants, another endosymbiotic event, the uptake of a cyanobacterium like organism to form the precursor of chloroplasts occurred but only in the eukaryotic plant lineage. Plants are unicellular/multicellular photosynthetic organisms primarily adapted for terrestrial life. Their characteristics are best understood in terms of the transition (migration of plant life) from water to land, an event that occurred some years ago.

By the time of the earliest known eukaryotes-about 1.5 billion years ago – a number of distinct lines of simple photosynthetic eukaryotes had already evolved. The approximately 30,000 described species of photosynthetic eukaryotes now in existence are classified in six divisions.

Three of these (Euglenophyta, Chrysophyta, and Dinoflagellata) consist almost entirely of unicellular organisms. The other three divisions (Chlorophyta, Rhodophyta, and Phaeophyta) include groups that are multicellular. The plants are thought to have originated from green algae of division Chlorophyta. Both, the plants and green algae contain chlorophyll **a** and **b** and beta-Carotene as their photosynthetic pigments, and they accumulate their food reserves in the form of starch (stored in plastids). The constellation of characteristics that could have given rise to the plants is found among contemporary green algae only in some members of class Charophyceae, most strikingly in the genus *Coleochaete*. Although *Coleochaete* does not seem to have been the algae from which the plants evolved, it is thought to be closely related to it.

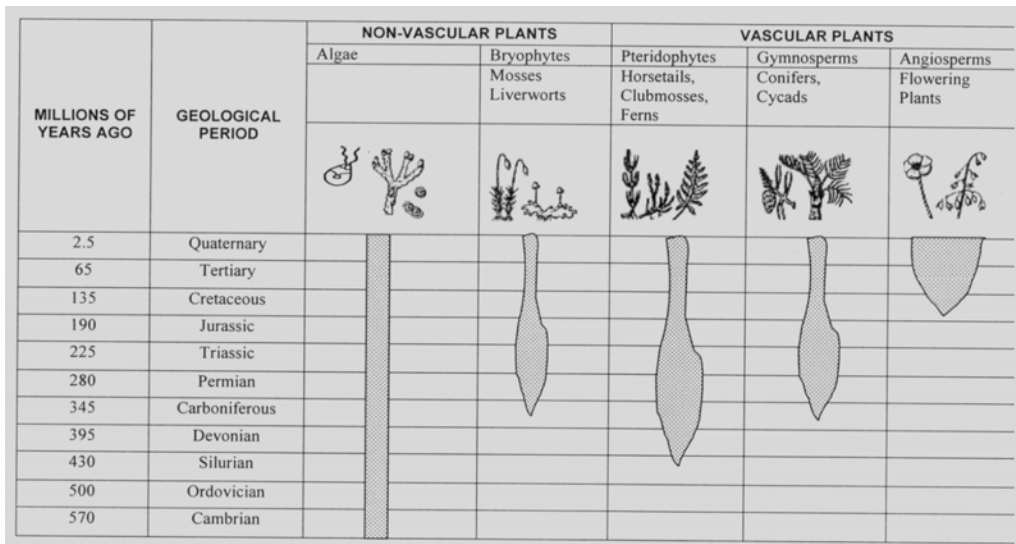

Figure 1 - Geological Time Scale showing origin of Green plants

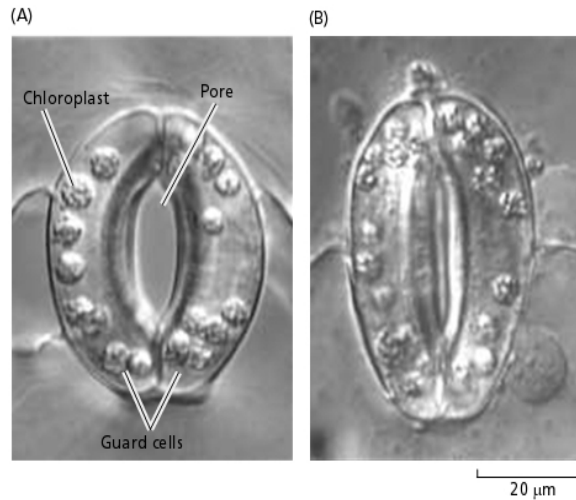

Figure 2 - Development of stomatal pores was major adaptation of the land plants.

(A) Open stomata (B) Closed stomata

At the time of migration to land ancestors of plants had evolved a well-defined alternation of heteromorphic generation. After the transition to land new adaptations began to evolve in the land plants. Development of cuticle (found of a waxy substance cutin secreted by the epidermal cell) and stomatal pores were major adaptations.

Another adaptation was the development of multicellular reproductive organs. A correlated adaptation was the retention of the fertilized egg (the zygote) within the female reproductive organ and its development there into an embryo (in the Embryophytes). Thus, during its critical early stages of development, the embryo, or young sporophyte, is protected by the female tissues/organs.

After transition to land, the green plants diverged into at least two separate lineages - the bryophytes and the vascular plants (all the larger land plants-the Tracheophytes). The vascular plants can be grouped into those without seeds and those with seeds (Spermatophyta). The gymnosperms have “naked”, unprotected seeds. The angiosperms have enclosed/covered/ protected seeds, and are, formally the Anthophytes, the true/flowering plants.

Goldberg (1988) outlined that many biological processes are unique/specific to plants. The area of plant development is under intense scrutiny and during recent past an understanding of the molecular/genetic processes controlling gene expression during plant development has emerged as major subject. A zygote – a reproductive single cell produces higher plants or animals – the multicellular organization. The zygote is product of fertilization between egg cell (female gametes) and sperm mate (gamete). A multistep process of embryogenesis transforms the zygote into a multicellular and complex organism. In higher animals, the mature embryos is a miniature variant of the adult animal, and whatever changes may take place during post embryonic development, they occur within the confines of the body organization established during embryogenesis. In contrast a plant embryo generates a juvenile form, the seedling which lacks most species-specific features of the adult plant. The main embryonic body axis, on its opposite ends maintains two primary meristems, the stem-cell systems.

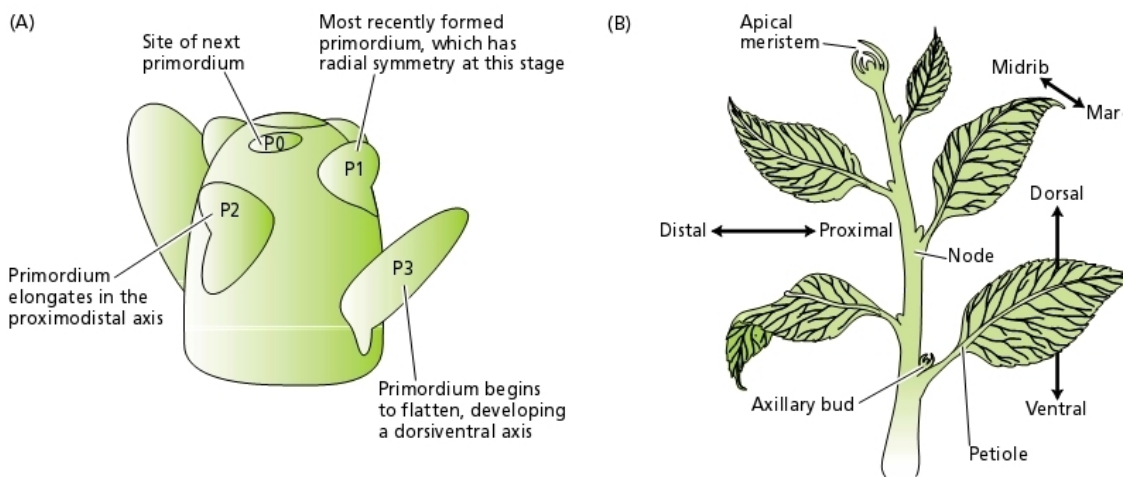

Figure 3 - The Origin of Leaves on the Shoot Apex and their axes of Symmetry on the stem (A) leaf primordia in the flank of the shoot apical meristem. (B) Shoot showing various axes along which development occurs.

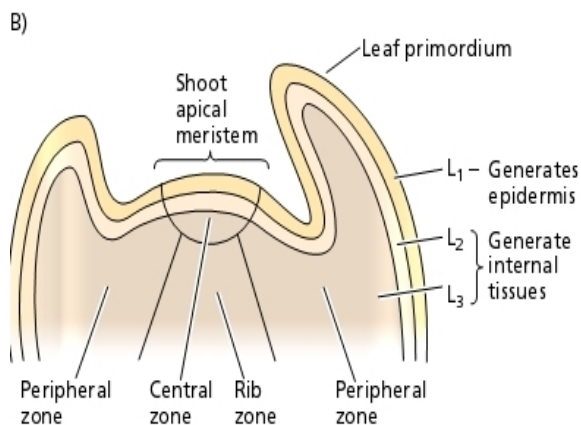

Figure 4 - Shoot Apical Meristem as a source of different tissues and organ types in Plants

The primary shoot meristems at the top end, is the source of cells for new organs, such as leaves, and secondary shoot meristem, including flowers. The primary root meristem at the bottom produces cells for extension growth of primary roots. Root branches are initiated from specific cell groups within the primary root. These primordia recapitulate radial patterning and root meristem establishment as occurs in embryogenesis. The basic body organization is laid down during embryogenesis. This gives rise to complex architecture of a plant body.

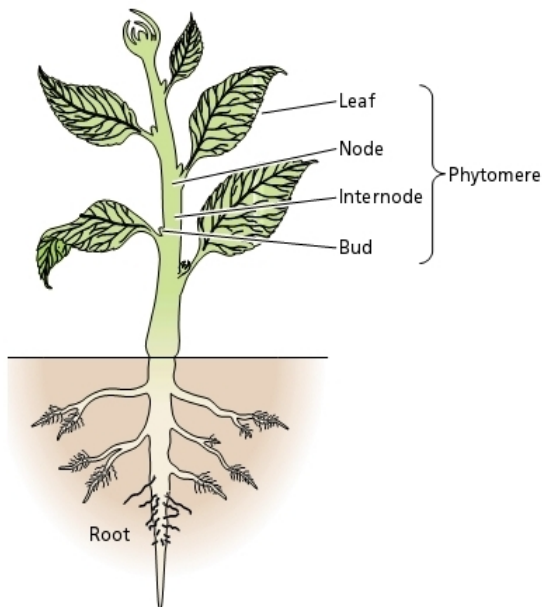

Figure 5 - The Shoot apical meristem repetitively forms units known as phytomeres. Each phytomere consists of one or more leaves, the internodes immediately below the leaves, and one or more buds in the axils of the leaves.

The seedling body organization can be viewed as a superimposition of two patterns: an apical – basal pattern along the main axis of polarity and radial pattern across the axis. Apical – basal pattern elements are, from top to bottom: meristem, one or two cotyledons (embryonic leaves), hypocotyl (embryonic stem), radicle (embryonic root), and root meristem. The radial pattern consist of tissue layers that are arranged concentrically from the periphery to the center: epidermis, cortex, and endodermis (both derived from ground tissue), pericycle and vascular tissue (xylem and phloem).

Plants are diverse groups of organisms:

Plants are generally thought of as flowering plants species such as trees, shrubs, vegetable crops and ornamentals. Though flowering plants constitute more than 90% of the 2, 75,000 known plant species, the plant kingdom also contains diverse group of non-flowering plants with unique biological characteristics. Non-vascular plants, such as Blue-green algae (Cyanobacteria), Algae and mosses do not have specialized water-conducting and food conducting tissues and therefore lack true leaves, stems, and roots. On the other hand by contrast, vascular (both the seedless and seed-producing) plants have highly differentiated xylem and phloem cells that conduct water and food over great distance. Both plant groups are though to have evolved from common green multicellular algae more than 450 million years ago. Nevertheless both non-vascular and vascular plants share common characteristics and hence these are placed in the same kingdom.

- (1) Both are photosynthetic multicellular eukaryotic organisms that are highly adapted for growth and reproduction on land.
- (2) Cellulose is major polysaccharide found in cells walls of non-vascular and vascular plants, and in both the groups a cell plate is formed during cell division.
- (3) Each has an alternation of a diploid spore-producing generation (sporophytic) and a haploid gamete-producing generation (gametophytic) in its life cycle Meiosis in all plant species, unlike that

in animals, yields haploid spores rather than gametes. In vascular plants, the sporophyte phase dominates and the gametophytic phase is dependent on the sporophyte for nutrition and support. By contrast the gametophyte is free-living in non-vascular plants and dominates the life cycle. Thus non-vascular plants are ideally suited for studying processes that are dominant in the gametophyte, e.g. gamete production.

- (4) Finally both vascular and non-vascular plants store glucose as starch in their chloroplasts and utilize both chlorophyll **a** and chlorophyll **b** as light receptors.

On migration to land (still unoccupied by forms of life), photosynthetic organisms did not face any competition and found abundant light and plentiful of CO₂ available with greater ease. Terrestrial life, however, presented light harvesting organisms with a new and major difficulty/challenge, that of obtaining and retaining/storage adequate amount of water. Green plants gradually solved this problem by evolving and acquiring multicellularity, which made possible specialization on a broad scale - development resulting in cells/or group of cells specialized for particular functions. Specialization brought with it a vast increase in the size of the organism. This in turn created additional constraints to face like increased demand for food and its supply, energy and transport. A larger and complex body required more physical support, coordination/integration of activities for smooth functioning of the entire organism, time required for the development of the organism increased, requiring protection and nourishment of the immature state. During evolution, probably a series of natural experiments represented/created to address the problems. As a result a diversity of multicellular photosynthetic organisms evolved, that occupies most of the earth's land surface for at least (300 millions) years.

Concept of Cell Theory

Robert Hook, in 1665 described the cellular nature of biological materials. **Matthias Schleiden**, a botanist and **Theodore Schwann**, a Zoologist stated the principle that cells represent the elements from which all plant and animal tissues are constructed. The cell theory they proposed suggested that all eukaryotic organisms are composed of cells, and that cells are the smallest independent units of life. Until middle of the 19th Century it became clear that both, plants and animals are multicellular in nature. The cell theory has been key factor in shaping the modern biological sciences. A new biology of 21st Century will probably also remain equally influenced by the cell theory. Though, some authors believe that during 20th Century cell theory turned into rather a dogmatic cell doctrine. **Balaska et al (2004)** argued that, in its current version, the generalized Cell theory developed for both animals and plants is unable to accommodate the supracellular nature (which is founded upon a super-symplasm of interconnected cells into which is woven apoplasm, symplasm and super-apoplasm) of higher plants. Recent advances in plant cell biology have presented evidences that challenge the compatibility of cell theory to explain a cell-based organization of higher plants (Supracellular plants do not fit the classical cell theory) and requires an up-date. Formulation of organism theory of plant development is postulated in which it is stated that it is not the cell but whole multicellular organism that is primary unit of plant life. There is a concept that present - day eukaryotic cells represent assemblages of "cells within a cell" and that all higher plants are supracellular organisms. Almost all the cells of a given plant organism are interconnected via cell-to-cell channel known as plasmodesmata that form primarily across the division wall at cytokinesis, and secondarily across selected, already established walls. Protoplasting (All of the numerous plasmodesmata connections are severed/broken off during isolation of plant protoplasts) of almost all plant parts of numerous plant species prove that multicellular plants are produced from single cell. Thus plants are produced from single cell and thus concept of supracellular nature of plant seems to be argumental only.

Growth and Development in Plants

Growth:

Growth, differentiation, and morphogenesis are three basic features of plant development. Growth is defined as the gain of volume and/or mass of an organism due to increase in size of cell(s) and their number. Single cells show two major components of growth-division and enlargement/expansion. The structure of the mature plant is result of cells undergoing these processes in an exquisitely controlled fashion in both space/place and time. The growth in higher plants does not occur in isolation. Growing cells apparently

signal to each other directly or receive signals/cues from a distance. Nutritional sources, sinks and the environmental factors (light, CO₂, water, minerals, and the neighbors) modulate these signals.

A size increase of the whole organism is easily recognized. A change in diameter, height, volume and weight can be observed, recorded and measured. The biochemical properties, such as pigment content, enzyme activity; and protein, RNA and DNA content of growing plant may also be established and measured. However, these measurements are the sum of the activities in an entire organism. Since plant consists of many different organs, and tissues which are composed of many cells, one has to ask/confirm whether the externally visible and biochemically measured growth reflects that of the whole organism or of just single parts.

Division of Plant Cells:

Every cell has its developmental cycle (Each cell passes through regular orderly sequence of events) the cell cycle. The cell cycle is normally completed in a few days. The cell cycle shows distinct phases: a longer phase with intensive synthesis and decondensed chromatin (the interphase), and the shorter phase condensed chromosome during which nuclear and cell division occur (the Mitotic phase). The interphase may be divided into three clear subphases/stages: during the S phase, DNA replicates and DNA-binding histone proteins are synthesized; in the preceding G₁ and following G₂ phase (G=Gap) RNA and proteins (except histone proteins) are synthesized. The mitotic phase (M-phase) can also be divided into prophase, metaphase, anaphase, and telophase.

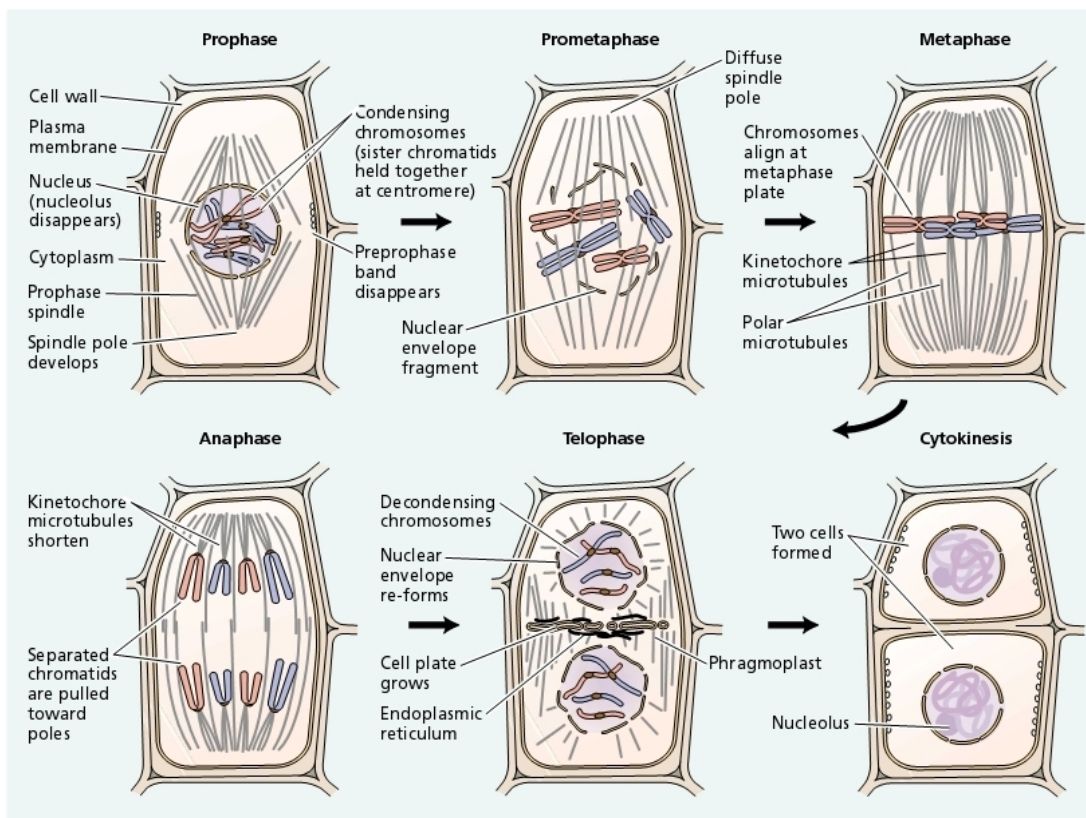

Figure 6 - Showing Mitosis in Plants

These divisions are based on the condensation and characterization of arrangement of the chromosomes and other specific cytological/nuclear features. Cytokinesis in plants is a rather unique process that implies the

formation of a new cell wall to separate the two daughter cells. It involves a very complex interplay of membrane and cytoskeleton components where membrane trafficking and vesicle fusion are of primary importance. Several variations in the cell cycle occur in nature. During the G_1 phase, cells monitor their size and their environment, whereas one of the tasks performed during the G_2 phase is to ensure that DNA duplication has been completed. The existence of the $G_1 \rightarrow S$ and $G_2 \rightarrow M$ checkpoints was discovered in plants by Van't Hof as early as 1966. It is suggested that the capacity to progress through cell cycle relies on a molecular entity. Sir Paul Nurse (1981) identified the Cdc 2 gene of fission yeast, whose gene product was genetically proven to be required for progression through both the $G_1 \rightarrow S$ and $G_2 \rightarrow M$ transition points, a finding rewarded with Nobel prize in 2002 (De Veylder 2003). The high conservation of cell cycle regulators is one of the most striking features of the evolution of cell cycle control. In short, cell cycle transition in all eukaryotes including plants, are tightly regulated by the activity of cyclin-dependent kinases (CDKs) formed by a catalytic subunit and a cyclin regulatory subunit. In addition, CDK activity is further modulated by inhibitors, and also by activators. Progression through the cell cycle requires duplication of the genetic material and the delivery of the newly duplicated genomes to the two daughter cells during mitosis. This occurs in coordination with increases in other cellular components and changes in cell architecture and it represents one of the key processes in living organisms. In individual cells cycle is regulated both in time (temporal) and space (spatial). Ramirez-Parra et al (2005) suggested that it is more appropriate to consider the concept of cell proliferation, instead of cell division, since it includes cell cycle control itself, cell cycle arrest and reactivation, endocycle, cell differentiation and cell death. In addition, these processes considered at the cellular level, must be coupled to the particular ontogenic program. The multicellular body plan of plants imposes extra layers of complexity and hence requires additional regulation. Acquisition of multicellularity is probably one source of evolutionary differences in the regulation of cellular processes.

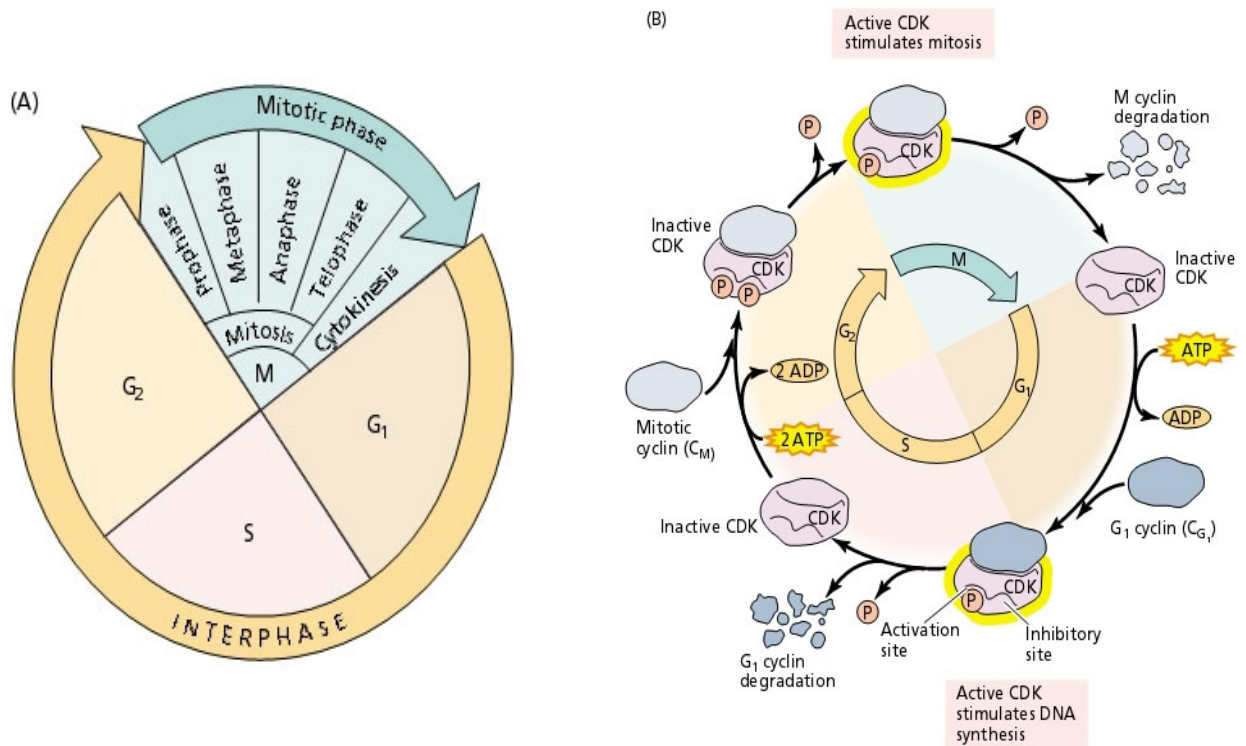

Figure 7 - (A) Diagram Of The Cell Cycle.(B) Diagram Of The Regulation Of The Cell cycle by cyclin-dependent kinase (CDK).During G_1 ,CDK is in inactive form .CDK becomes activated by binding to G_1 cyclin (C_{G_1}) and by being phosphorylated (P) at the inactivation site. The activated CDK-cyclin complex allows the transition to the S phase. At the end of the S phase, the G_1 cyclin is degraded and the CDK is phosphorylated, resulting in an inactive CDK. The cell enters G_2 .During G_2 the inactive CDK binds to the

mitotic cyclin (CM), or M cyclin. At the same time, the CDK-cyclin becomes phosphorylated at both its activation and its inhibitory sites. The CDK-cyclin complex is still inactive because the inhibitory site is phosphorylated. The inactive complex becomes activated when the phosphate is removed from the inhibitory site by a protein phosphatase. The activated CDK then stimulates the transition from G₂ to mitosis. At the end of mitosis, the mitotic cyclin is degraded and the remaining phosphate at the activation site is removed by the phosphatase, and the cell enters G₁ again.

Cell division and its role in determination:

The processes which make possible that a cell gives rise to two daughter cells define the cell division cycle. The processes that occur between cell birth and subsequent cell division define cell cycle. This is characterized by a unidirectional series of events, in some cases interdependent, that ensures correct duplication of the cell, including cytoplasmic and nuclear material and, in the case of plants, also the cell wall. It has become evident that cell division and proliferation is influenced by genetic background as well as by extra cellular cues. In the post embryonic development of plants, organism growth requires the coordination of cell proliferation with cell differentiation in continuous manner. This extended proliferation potential is influenced by several phytohormones with auxins and cytokinins (CKs) having the most extensively documented roles in controlling the transcriptional expression of several cell cycle genes. Other plant growth regulators such as Abscisic Acid (ABA), Ethylene (Et), Jasmonic acid (JA) and Brassinosteroids (BRs), whose actions are much less well characterized, also have an impact on cell cycle progression and/or its arrest. Cell divisions provide a means to compartmentalize and stabilize cytological differences that underline cell determination or cell differentiation. Cell division is inextricably linked with determination and differentiation. But, it must be viewed as separate from both. Evidences exist from mutants that affect cell proliferation without affecting pattern formation or organ fate.

The duration of cell cycle on the orientation of the cell division have an obvious effect on the developing organs and the final shape of the entire organisms. This is reflected in the term **formative growth**, which contrasts with **proliferative** (mass-gaining) **growth**. Progression through cell cycle occurs in coordination with increases in other cellular components and changes in cell architecture and it represents one of the key processes in plant/living organisms. In addition to the temporal and spatial regulation of the cell division cycle, the acquisition of multicellular body plan imposes extra layer of complexity and regulation. Multicellularity is probably one source of evolutionary differences in the regulation of cellular processes. In fact, it is more appropriate to consider the concept of cell proliferation, instead of cell division, since it includes cell cycle which controls itself, cell cycle arrest and reactivation, cell differentiation and cell death. In addition, these processes considered at the cellular level must be coupled to the particular ontogenic program. Organ initiation and growth in plants is a post-embryonic and continuous process that occurs over the entire lifespan of the organism. This remarkable fact relies on the existence of stem cell, niches e.g. in the shoot and root apical meristems that continuously provide new cells that eventually take specific differentiation patterns. The ability of the cells to regenerate is remarkable property of plants. Cells in certain locations can dedifferentiate, and revert to a totipotent (or pluripotent) state, proliferate in a highly controlled manner and take multiple cell fates to form an entire organ or adult plant.

These processes involve specific regulatory network that impinge on cell proliferation. Thus, an increasing interest focuses on answering the question of whether our current concepts of cell cycle regulatory components in addition to controlling cell cycle progression, also have some roles in the coordination of cell division in the context of a developing organism. Altering cell cycle control has profound consequences in organogenesis, although plants seem to be very tolerant to changes in the level of cell cycle regulators. Furthermore disturbances in cell proliferation are not associated with programmed cell death or on oncogenic transformation, as it occurs in animals.

The control of cell proliferation and differentiation during development depends, in most cases, on the concentrated action of plant growth regulators/plant hormones. Among them, auxins and cytokinins are the best documented and they can impinge directly on cell cycle regulators. In addition, other hormones, e.g. abscisic acid, ethylene, jasmonic acid, brassinosteroids and salicylic acid, whose action is much less well characterized also, have an impact on cell cycle progression and arrest.

Some authors consider all division that lead to the production of daughter cells with different fates as asymmetric division, whether or not symmetry is morphologically evident at the time of division. Accordingly, any cell division that generates daughter cells with different fates is asymmetric by definition.

Symmetric Cell Divisions:

Most cell divisions are symmetric; two nearly equal daughter cells, morphologically indistinguishable are produced and they become different after cytokinesis. These differences arise by differential gene expression and synthesis of different proteins during G1 and/or G2 of the cell cycle. An accumulation of discernible morphological differences in these cases may occur abruptly after a single cell division or may occur gradually over several cell cycles, and leads to a progressive canalization of a cells potentialities.

How two daughter cells immediately after a symmetric division come to express different genes or how the cytoplasm becomes asymmetrically organized before an asymmetric division is mystery about which we still know very little. Studies on *in vitro* fertilization in maize and on axis formation in zygotes of **Fucales** suggest that cytoplasmic asymmetries can be and indeed are established previously (preceding). Symmetrically disposed cause changes in cytoskeleton, which, in turn, affect the cytoplasm and organelles to become asymmetrically disposed in the cell. The cytoskeleton probably plays a similar role in creating cytoplasmic asymmetries in higher plant cells to cell to cell communication may also be involved.

Asymmetric Cell Divisions:

Asymmetric cell divisions have long been considered as a prelude to determination. In the asymmetric divisions, two daughter cells of unequal size are produced and these inherit different complements of cytoplasm and organelles (e.g., the first transverse division in the zygote, division separating a trichoblast from an atrichoplast in root epidermis of grasses, formation of (i) stomatal complex in leaf epidermis, (ii) companion cells and sieve elements in phloem tissue, (iii) generative and body cells in microspores of flowering plants. In many of these cases, the cytoplasm and organelles are asymmetrically distributed in the mother cell before cytokinesis. Products of gene activity (mRNAs and/or proteins) may also be asymmetrically distributed in these segments prior to portioning.

Cellular Polarity: Symmetrical/Asymmetrical

It is assumed that division of a cell gives birth to two daughter cells which are genetically identical at the same state of differentiation. However, this is not always the case. If the maternal cytoplasm is not evenly distributed, the two nuclei in the daughter cells have different cytoplasmic environments. This may for example, results in differing complements of plastids and mitochondria and may lead to differential gene expression patterns in the two daughter cells and their offspring. These dissimilar cell divisions are very important for the development. In the plants, the first division of the zygote, and the formation of pollen grains, stomata, or trichome.

The uneven distribution of cytoplasm is circumscribed by the term **Cell Polarity**, i.e. the composition and the features of the cytoplasm change from pole to pole along a polarity axis. The cellularity may be permanent; however, in most instances there is a phase during which cell polarity can be changed before, it is fixed. Such a change of cell polarity can be induced by external factors like light and electrical fields but only as long as the polarity axis are not fixed endogenously.

Plant systems with single or only a few cells are used to demonstrate cellular polarity. Spores of genus *Equisetum* (Horsetails), gametophytes of the fern *Dryopteris*, and protonema of the moss *Funaria* are suitable systems for studying cellular polarity. Zygotes of the brown algal genus *Fucus* have been very useful particularly rewarding. The zygotic cells are about 100 μm in diameter and are initially apolar. These, however, form a polar axis 4–10 hours after fertilization which can still be influenced experimentally. Ten to Twelve hours after fertilization the axis is fixed. A localized protrusion appears that indicates the site of rhizoid initiation. After next 12 hours, the first cell division occurs, perpendicular to the polar axis of the zygote. This asymmetrical cell division forms a small rhizoid and larger thalloid structure. Further characteristics cell divisions produce the initially spherical thallus, which becomes lobed later, and the branched rhizoids.

Plant Cell Enlargement-

In plant cells, there are two different mechanisms of volume and mass growth: increase in biomass and enlargement by stretching. Plant cells gain most of their additional biomass after mitosis. During stretching, frequently the amount of cytoplasm remain constant or decreases slightly, and it does not necessarily involve an increase of organic substances vacuoles are formed. Volume increases of the whole cell are due to intake of water. This leads to stretching of the cell wall and its surface growth. Expansion of cell well is usually limited to one direction and stretching is not in all directions. Thus this is referred as growth by stretching. The prosenchymatic cells are elongated and these transport substances. These contribute in part to the rigidity of the plant structure are an example of plant cells that exhibit selected stretching. The cells of bamboo shoots stretch with an average speed of more than 500 mm/day (400µm/minute) over several days. These achieve the top value of speed and duration of elongation. Still faster elongation (2500 µm/minute) has been measured in the stamens of rye. However, the elongation here is completed after 10 minutes.

Differentiation: Specialization of forms and functions

Growth deals with quantitative changes during development. Differentiation describes the qualitative changes. Organogenesis results in the morphological differences which coincide with specialized functions.

Differentiation is defined as changes of the morphology and functions of cells, tissues and plant organs.

Development involves not only growth but also differentiation, the process of progressive specialization of plant tissues and organs. Cells become determined, presumably by specific inducers. As follow one of many defined developmental programs.

The cellular unfolding of development and cytochemistry reveal the molecular biological outcomes that are associated with events of differentiation in plants. Function of different tissues is assigned. Modern developmental biologists can delve deeper and aim to understand the genetic basis of morphogenesis as it occurs (including imposition of size, shape and subdivision of developing organs i.e. pattern formation, as well as genetic control of organ identity and tissue differentiation. The underlying programs are viewed as network of interacting gene activities. Each network generates sets of shared and specialized proteins in a defined sequence. The specialized proteins ultimately differentiate for example, a phloem cell from pollen grains.

As plants can not leave its place of origin, these are forced to face a wider range of conditions. They do face and survive changing environment by spreading developmental decisions throughout the life cycle. This ability enables the plants opportunity to tune plant body form and function to suit the varying environment. Often plants perceive subtle environment cues and initiate the developmental responses accordingly. Plants must combine the sensitivity required to respond to these signals with the ability to remain unaltered by environmental fluctuations that do not represent a signal. Plants exhibit great plasticity in morphogenesis. Plant plasticity is not simply phenotypic variation (caused by the inability to achieve canalization). Like other organisms plants have sophisticated mechanisms of canalization. Canalization is the capacity to buffer normal development against deleterious alterations caused by mutations or fluctuations of the environment. Most plant cells are immobile and thus have to inform each other about their relative position through exchange of chemical signals. Such cell to cell communication is particularly important during the development (differentiate) of stem cells to form specialized tissue cells.

The organs of dicots and monocots have traditionally been summarized in term of dermal, ground, and vascular tissues. In contrast, over 40 different plant cell types have been identified. The reduction of all plant material into a mere three categories thus seems somewhat quaint.

Plants show an open form of growth:

Plants are unique organisms that retain the capacity for unlimited growth as they have meristems at certain locations in the body, which are composed of stem cells, which perpetuate themselves by cell division and

also give rise to derivative cells which differentiate along new lines. As a result of meristematic activity, fresh quotas of tissues and organs are formed and the plant continues to grow height and in many cases, throughout its life. This form of growth in plants is referred to as form of growth. Structural support for the plant body is made possible by the presence of cell walls. In young organs, turgor pressure inside cells also contributes to structural support. The presence of a cell wall is a mechanical necessity for plants because it provides rigidity and strength while allowing flexibility, but it also imposes major restrictive to cell growth.

Commitment, Determination and Differentiation

During embryogenesis and subsequent plant development, plant tissues and organs become determined and serve specific functions. In plants it is difficult to decide when “determination” occurs because (i) plants have open growth, they retain apical, lateral, and intercalary meristems and (ii) they show open differentiation, i.e. differentiated somatic cells or reproductive cells retain the possibility under certain circumstances to revert to an earlier or even the zygotic state. In contrast, in animals, the fate of a cell/tissue is “fixed” at some point in development and the cell/tissue may be considered to be determined at that point. “Determination” and “Commitment” have been used as synonymous terms in text books. Commitment is defined as being cast in a state where future developmental potentialities became restricted. In molecular genetic term, this means restriction on parts of genome that can be transcribed in a cell or its daughters. Determination is relative. No cell type, including the fertilized egg or zygote, is completely “undetermined”; some cells/tissues are more determined than others, which means that they have a fewer number of future choices open to them than the less determined ones. Determination and differentiation are used as synonymous words, as distinction between the two terms is subtle and tenuous. Differentiation is the process whereby cells from a common origin become different suddenly. Formation of glandular /epidermal hairs is such examples. Vascular cambium when established is committed to giving rise to derivatives by specific planes of cell division, and the derivatives in turn are committed to forming xylem or phloem cells. The future developmental potentialities are thus restricted in each case of the protoderm, procambium and vascular cambium. Plant development, like that of other multicellular organisms, is epigenetic and can be compared to a computer desktop opening of folders within folders, within folders, within folders.

Commitment during embryogenesis-

A zygotic cell in plants divides into an apical and a basal cell which give rise to the embryo proper and suspensor, respectively. This is illustration of commitment, as in the subsequently, a root pole and shoot pole are defined in the embryos, and at the short pole a shoot apical meristem and cotyledons. At the tissue level, the protoderm is separated from the central cells, followed by the separation of the central cells into ground meristem and procambium, and still later, in roots, of the ground meristem into cortex and endodermis, and of cambium into pericycle and vascular tissues. At each step, the choices are limited to two options, and the developmental potentialities of the derivatives are more restricted than those of the parent cell. Some authors regard commitment as a series of “portioning” events. Thus, protoderm, ground meristem, and procambial cells are more determined than the eight-cell proembryo that gave rise to them, and the nature of the derivatives is already determined. Protoderm cells normally will form epidermis, epidermal hairs, guard cells, and elaborate cuticle, but will not form xylem or phloem cells. The procambial cells normally will form, vascular tissues; pericycle and vascular cambium and will not. There are several other examples of polyembryony in angiosperms e.g. apomictic embryos result from cells of the embryo sac or nucellus. These cases may also involve a relaxation in the control exercised by the zygote or the young embryo over the embryogenic potential of neighboring cells. Leaf primordia arise on the shoot apex in strict and species-specific patterns (**phyllotaxy**).

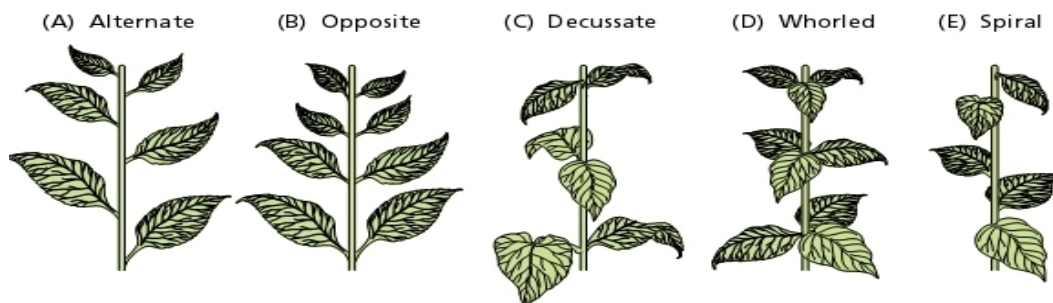

Figure 8 - Five types of leaf arrangements (phyllotaxy) along the shoot axis. The same terms also are used for inflorescences and flowers.

If the youngest leaf primordium is damaged/surgically, the new leaf primordium arises not in its predicted position, but closer to damaged one.

As the origin of different tissue layers known, surgical or laser beam ablation experiments can be used to collect experimental data on effect of positional cues on determination. If cells of the quiescent center in a root apex are damaged by laser beam (ablation), the neighboring cells originating from vascular initials assume the characteristic of and become the new quiescent center cells. If cortical initial cells are ablated, neighboring pericycle cells divide periclinally of the two daughter cells, one stays in the pericycle and the other enters in the space vacated by the dead cortical initial, which subsequently divides again to form an endodermal cell and a cortical cell. Cambial initials provide an elegant (but less known) example of positional cues and intercellular communication. The cambial initials occur as a single layer of cells that divide periclinally to produce secondary xylem (wood) and secondary phloem. Regularity of annual rings (in wood), formed reveal that numerous fusiform initials divide periclinally, more or less in concert with each other in unison fusiform initials in a tree with wood cylinder 1 m in diameter.

Cell Lineage vs Positional Cues in Plant systems:

Many plant biologists believe that the fate of a cell is determined by the position it occupies in the plant body rather than by its lineage. Genetic analyses of shoot apices/developing leaves of maize, tobacco, and *Arabidopsis* have revealed that cell lineages, although important are not a reliable indicators of the eventual fate of a cell. The fate of a cell in plants is determined more by the position it occupies in the plant organ/body than by the manner in which it is derived. Hence, the commitment to a specific fate is flexible within limits; it is delayed until the position of the cell/organ in relation to its neighbors and the environment is secure. Positional cues imply that environmental factors, as well as existing tissues and organs, exert an influence on determination/differentiation of new tissues and organs. Evidence for positional cues comes from mutants and from surgical or laser-induced ablation experiments in which a cell layer or tissue is damaged and neighboring cells assume the function of the damaged cells/tissues. Formation of second embryo from suspensor cells results in polyembryony. In some cases multiple embryos are formed from the basal cells if apical cell and its descendants are arrested. This process is slow. The demarcation during transitional stages involves a blocking out of domains, followed by sub-domains, and sub-domains in a progressive manner, leading to a commitment of individual cells for specific fates. A clear demarcation, therefore, as to where determination ends and differentiation begins is not possible, but the context in which they are used usually makes the meaning clear. Differentiation could be considered as the “detectable manifestation” of determination, but “detection” at what level, macroscopic, cellular or molecular? Commitment occurs in steps: Plant development is hierarchical and involves a series of progressive commitments. Polarities and patterns are established very early in plant development, others are established later, and still others are established even later.

Determination: the commitment to differentiation fates

A plant cell isolated from a tissue has a broad developmental potential. This is evident during its regeneration to an intact plant, when a large number of diverse daughter cells from this single cell. However, every cell in a tissue can not develop as it pleases. The organism keeps control the development and the direction of differentiation of the individual cell. This kind of mechanism is essential for the development of a species-specific plant body. It is achieved by imposing increasing directional growth limitations on a plant cell. Most plant cells, apart from zygotes and early embryos, have a determined development. This often holds true even for callus cells, which may be determined to form roots, shoots or undergo somatic embryogenesis.

Callus cultures established from juvenile and mature *Hedera helix* (Ivy), differ morphologically and physiologically. The cells of the juvenile callus grow faster and are larger than those of the mature callus. Interesting enough, the juvenile callus regenerates in culture to form juvenile plants and the mature callus to mature plants (Westhoff, 1998). It has been suggested that determination of cells follow a certain differentiation route during which the participating cells change their molecular developmental repertoire step by step and are able to re-route the direction. Initially their differentiation is probably reversible. Before an irreversible state is attained the cells are likely to pass an in different phase in which the plant cell are capable of changing to new developmental directions. This ability is called developmental competence.

Mechanism of Differentiation

The changes are recognized even in organelles of a cell. A very well known example of this is the differentiation of plastids or mitochondria. In meristematic stem cell there are a few proplastids, 0.2 – 3.0 μm in diameter which may turn into protochloroplasts, chloroplasts, amoeboplasts, amyloplasts, etioplasts, elaioplasts, proteinoplasts, chromoplasts or gerontoplasts. This differentiation is visible externally because specific membrane structures and the pigments are formed or other specific chemicals are deposited. This differentiation of organelles however, is only part of the development that is controlled by the complete plant cell. The term differentiation is therefore often equated with cell differentiation. While differentiation is often limited to a single cell, which develops distinctly from all its neighbors (as an idioblast), normally groups of cells or specific region are affected; this is known as tissue or organ differentiation. Typically, differentiation leads from the meristematic cell to cell with specialized/special functions which can not divide. However, differentiation may also proceed in the opposite direction (termed re-embryonalization – closure of wounds with newly formed callus cells). Callus tissues, isolated cells cultures and protoplasts may be induced to renew differentiation. Single cells can be stimulated to regenerate to complete plants (protoplasts from mesophyll cells are often used), this is referred to as the totipotency of cells and reflects the fact. Single, completely differentiated plant cells can retain all necessary information for the development into any specialized cell type. Normally, fully differentiated cells first form meristematic cells which consequently, re-differentiate. However, there are known exceptions, for example, in tissue cultures the isolated mesophyll cells of *Zinnia elegans* differentiate directly to form specialized cell shape (the *tracheary* elements).

In a multicellular organism, cells and tissues serve specific functions, for which they have been specialized. The functions are performed efficiently and to the benefit of the whole organism, but at the price that the specialized cells, tissues, and organs have only limited parts of their genome open for transcription. Thus/For example, a typical leaf mesophyll cell, which is specialized for photosynthesis, may have 40 – 50 well differentiated chloroplasts, about 10^6 molecules of photoreceptors, chlorophylls a and b, about the same number of associated CHL a and CHL b proteins and 10^8 molecules of ribulose 1,5-bisphosphate carboxylase/oxygenase (RUBISCO), the principal carbon fixing enzymes. In contrast, a root parenchyma cell, which is not doing much else besides storing starch will have no chloroplasts, no chlorophyll and associated proteins, and no RUBISCO, instead it would have amyloplasts (Starch-storing plastids) and large amounts of ADP-glucose pyrophosphorylase, one of the major starch-synthesizing enzymes in nonphotosynthetic tissues. The root and mesophyll cells have the same genomic DNA but they are specialized for different functions because different genes are expressed in two types of cells.

Differential gene expression here means in a broad sense to incorporate/include not only transcription, but also posttranscriptional and posttranslational modification as well as gene silencing. Differential gene activity

is the basis for the phenomenon known as epigenesis, the unfolding of the developmental program of an organism.

Gene activity involves at least three types of genes (i) housekeeping genes that encoded proteins required for general housekeeping, such as enzymes involved in respiration, sugar uptake, or synthesis of proteins or synthesis/replication of nucleotides and polynucleotides, (ii) genes that are expressed in a cell and tissue specific manner and which encode proteins that are specific for the canalized route or the designated function; and (iv) regulatory genes that specify pattern or that regulate the expression of cell/tissue specifically. At the same time, there is a progressive “shutting down” of the parts of genome that are not going to be necessary for destined function of the cell. The Regulatory Genes are involved in perception of signals/cues.

Most regulatory genes in plants encode transcription factors or proteins involved in signaling, such as receptor-like kinases. There are many different kinds of transcription factors encoded by multigene families. They include homeobox genes. Many transcription factors specify patterns of future development by regulating the expression of structural genes that encode cell/tissue specific proteins, while some modify the action of other transcription factors products of regulatory genes are probably involved in the perception of environmental and or hormonal signals including signals from neighboring cells. Some examples of regulatory genes involved in the determination of identity, or size, of shoot meristem are

1. Shoot Meristem Identity genes
2. Floral Meristem and Organ Identity
3. Size of shoot Meristem and Lateral Organs

Morphogenesis: Developing the form of the complete organism

Cell and tissue differentiation results in a typical and recognizable external appearance of the organism. The basic body form of the body, however, is not fixed. It changes during the developmental process. One can discover divergent forms or alterations in symmetry. During plant ontogenesis all kinds of symmetries are exhibited. The spherical/globular early embryo has a radial symmetry; with further development of embryo this symmetry becomes bilateral — the two halves of the plant are mirror images. This is particularly evident during the formation of two cotyledons in angiosperm embryos. However, there are obvious differences between the apical and the basal halves of the embryos which form the shoot or the root precursors. During the development of the flowers (but not of the embryo) we often see dorsiventral symmetry. Here there are differences on the upper and the lower sides. Metameric symmetry is another type, where the elements along an axis are formed at the same distance and have similar orientations with respect to one another. Special forms develop when the axis is spiral or a helix. Any combination of basic forms having two types of symmetry produces new overlapping symmetries that are very complex. The whorled arrangement of leaves on the stem illustrates these complexities.

Morphogenesis summarizes the visible expression of a number of highly complex processes. It includes newly formed structures (Embryos from the zygote) and changes in form and function (i.e. seedling development, the transition from seedling to adult plant, the formation of flowers, seed, and fruit, and senescence in annual plants).

The crossing of plants and analyses of (i) phenotypes/genotypes of hybrids and (ii) mutations and modern methods of molecular genetics and reverse genetics have revealed that endogenous regulation of development in plants reside in specific gene(s). In contrast to embryogeny, which is largely regulated by endogenous factors, the other main phases of plant development are strongly influenced by additional environmental factors. The development of seedlings in the light (Photomorphogenesis) or in the dark (Scotomorphogenesis) is one example. Another is light and temperature-induced flowering in plants. Pathogen/disease-induced abnormalities are other examples of interactions between internal and external factors.

Pathological Morphogenesis

Morphogenic processes that are not part of the normal development of the individual for example the formation of root nodules tumors and galls and other abnormalities offer apart from their practical importance, extremes of plant development. Much can be learned from these processes.

Regulation of Development in multicellular Plants

Differentiation and morphogenesis exhibit changes in time and space. These changes lead to the differentiation of cells and tissues and eventually to the expression of a pattern. The formation of patterns however, does not occur randomly. These follow a pre-determined plan within certain limiting boundaries.

Pattern formation in plants:

Pattern is the non-random distribution of structures in individual organelles or in the organism. Pattern formation therefore describes the spatial organization of differentiating parts to a higher level of organization. This organized system acquires a form. Two separate very well defined phases exist in pattern formation- an initial pattern specification and a final pattern realization. This obviously means that patterns are predetermined and inherently present before they are visible externally. This irreversible factor is called “determination”. Thus determination is the commitment of cells along a particular and virtually irreversible path of differentiation. The ability of a cell, the organelle, or organism to complete a specific section of development is termed as competence.

The cellular structure of plants is due to the fact that many related cells within a developing tissue or plant organ follow simultaneous developmental step. However, comparable local cellular differentiation is frequently separated in space and/or time. Also, neighboring cells in a tissue can adopt different developmental strategies. This leads to morphological and physiological differences within form externally visible patterns. The ordered arrangement of leaves (*Phyllotaxis*) and the branching of roots and shoots are also examples of cellular patterns. The distributions of stomata and trichomes in the epidermis belong to this type of pattern. The causes of pattern formation are unknown. One important clue may be the observations that pattern always start with asymmetrical cell divisions. This is obvious during the development of stomata, which are important for the exchange of gases and osmoregulation by the plant but vary in their morphology in different plant groups.

Cell-cell contact and Long-distance effects in plants

Pattern formation is closely linked to the question of communication between cells, their neighbors, and their surroundings. In plants, plasmodesmata and the cell wall probably play key role in cell-cell communication. Such cell-cell communication is particularly important during the development (differentiation) of stem cells to form specialized tissue cells. The nature of signaling molecules is also not very clear. Proteins and their, mRNAs, cell wall components, and hormones are likely candidates. For instance the mRNA for KNOTTED 1 and the expressed proteins are transmitted to tunica 1 layer via plasmodesmata from the cells of shoot meristem. In *Fucus* zygote and two-celled embryo signals embedded/residing in the cell wall serve to provide cell fate information. Similarly, arabinogalactan proteins in cell of embryogenic cells during somatic embryogenesis and in pollen-stigma/style interaction in flowers are thought to act as recognition molecules for cell-cell interaction. An arabinogalactan protein has also been proposed as a cell to cell communication in *Zinnia* mesophyll cells in culture. Plant growth regulators have long been considered as signaling molecules for intercellular communication, but an unequivocal demonstration of their role in fate determination is lacking. Recently two small peptides have been isolated from plants that fulfill short-range signaling functions. Both of these peptides are derived from precursor proteins belonging to the (almost) plant-exclusive CLE family and are very similar in amino acid sequence, but one promotes and the other suppresses stem cell differentiation during shoot and vascular development.

The idea that concentration gradients of signaling molecules might provide mechanisms to pattern body plans of multicellular organisms is long established. The term “morphogen” itself was coined in 1952 to describe ‘form-generating substances’. The concept of morphogen is very well accepted to explain the molecular basis of pattern formation in many developmental contexts. Animals use concentration gradient of signals

(morphogenes) for tissue patterning, but whether they are also used by plants is unclear. Bhalerao and Bennett (2003) of the Swedish University of Agricultural Sciences compared and contrasted the plant growth regulator auxin with animal's morphogenes, and speculated as to whether plants have independently evolved similar mechanisms to regulate pattern formation.

A plant can not leave its place of origin and can be forced to face a wider range of conditions including the hostile environments and predators. In order to face problems plants have to coordinate developmental processes between remote organs. Cell-cell transmission of signals would be slow and inefficient. Thus long-distance communications between organs (Correlations) rely upon the vascular system and frequently travel remarkable distances (Trees). This kind of communication may involve the long-distance transport of nutrients or plant growth substances with hormone like characteristics. In plants long-distance transport of nutrients or plant growth substances with hormone – like characteristics. The interfering substances that provide cross-protection against viral pathogens and the micro-RNAs may also be transported through long-distance transport system. Long-distance transport of organic substances occurs mainly via the sieve tubes which are connected with the companion cells by numerous plasmodesmata. Sieve tubes and companion cells form functional units. All organic substances travel through them from their site of synthesis (source) to that of their utilization (sink). The direction of transport may be downwards (i.e. from the leaves to the roots) as well as upwards (i.e. from the roots or other storage organs to the flowers or growing tips of the shoots). Interactions between plant organs may enhance or inhibit developmental processes. Promotion of cell division in the cambium of trees during the spring is influenced by the developing buds. The signals are auxins and probably other phytohormones which are transported from the bud downwards. The growth of many fruits depends upon correlative enhancement by transport of plant growth regulators from the ovule to the surrounding ovarian tissues. There are many examples of correlative inhibition in which the development of one organ is negatively influenced by another. The best known example is apical dominance. The tip of a plant or a branch of a tree inhibits the development of lateral shoots. If the tip is removed or branches are trimmed/pruned/lopped, the growth of the lateral/axillary shoots is promoted.

Plants are unique organisms that retain the capacity for unlimited growth as they have meristems at certain locations in the body, which are composed of stem cells, which perpetuate themselves by cell division and also give rise to derivative cells which differentiate along new lives. As a result of meristematic activity, fresh quotas of tissues and organs are formed and the plant continues to grow height, and in many cases, throughout its life. This form of growth in plants is referred to as a **gene form of growth**.

Structural support for the plant body is made possible by the presence of cell walls. In young organs, turgor pressure inside cells also contributes to structural support. The presence of a cell wall is a mechanical necessity for plants because it provides rigidity and strength while allowing flexibility, but it also imposes major restrictive to cell growth.

Morphogenesis: Developing the form of the complete organism

Cell and tissue differentiation results in a typical and recognizable external appearance of the organism. The basic form of the body however is not fixed. It changes during the developmental process. One can discover divergent forms or alterations in symmetry. During plant ontogenesis all kinds of symmetries are exhibited. The spherical/globular early embryo has a radial symmetry, with further development of embryo this symmetry becomes bilateral – the two halves of the plant are mirror images. This is particularly evident during the formation of two cotyledons in angiosperm embryos. However, there are obvious differences between the apical and the basal halves of the embryos which form the shoot or the root precursors. During the development of the flowers (but not of the embryo) we often see dorsoventral symmetry. Here there are differences on the upper and the lower sides. Metameric symmetry is another type, where the elements along an axis are formed at the same distance and have similar orientations with respect to one another. Special forms develop when the axis is spiral or a helix. Any combination of basic forms having two types of symmetry produces new overlapping symmetries that are very complex. The whorled arrangement of leaves on the stem illustrates these complexities.

Morphogenesis summarizes the visible expression of a number of highly complex processes. It includes newly formed structures (Embryos from the Zygote) and changes in form and function (i.e. seedling

development, the transition from seedling to adult plant, the formation of flowers, seed and fruit, and senescence in annual plants).

The crossing of plants and analyses of (i) phenotypes/genotypes of hybrids and (ii) mutations to and modern methods of molecular genetics and reverse genetics have revealed that endogenous regulation of development in plants reside in specific gene(s). In contrast to embryogeny, which is largely regulated by endogenous factors, the other main phases of plant development are strongly influenced by additional environmental factors. The development of seedlings in the light (photomorphogenesis) or in the dark (Skotomorphogenesis) is one example. Another is light and temperature induced flowering in plants. Pathogen/disease-induced abnormalities are other examples of interactions between internal and external factors.

Photomorphogenesis

Plants as photoautotrophs are exquisitely sensitive to their light environment. Not only is light the primary energy source for plants but also it provides them positional information to modulate their growth and developmental processes, including seed germination, seedling de-etiolation, gravitropism, phototropism, chloroplast movement, shade avoidance, neighborhood sensing, circadian rhythms and flowering time. Plants can detect almost all the facets of light including its direction, duration and periodicity, quantity and wave length. One of the key events in life cycle of plants is the acquisition of photosynthetic capacity and the re-direction of growth that takes place when dark-grown tissues emerge the soil and become exposed to the daily light cycle.

The developmental pattern followed in darkness is called Skotomorphogenesis, where plants have etiolated (with apical hook, folded cotyledons, elongated hypocotyls and bleached appearance). While that followed in the light is called photomorphogenesis. Once in light, if the proportion of red compared to far-red light is reduced by the presence of nearby neighbor, which selectively reflect and transmit far-red light, plants adopt a more competitive vegetative body form. Finally neighbor signals themselves or seasonal cues provided by the photoperiod can initiate the transition to the reproductive development (flowering) or the formation of vegetative reserve organs. Sunlight is also a critical information carrier for plants. Plants do not have eyes in a metazoan sense to sample and capture information from their light environment. Plants have evolved a number of diverse, nonopsin photoreceptors capable of perceiving a broad range of light qualities and intensities. Three major classes of photoreceptors are used by the plants to sample, sort and sense their light environment. Phytochromes predominantly absorb the red and far-red wavelengths (600–750 nm), whereas Cryptochromes and Phototropins perceive blue and ultraviolet A (UV-A, wavelengths 320–500 nm), and unidentified UV-B photoreceptors absorb UV-B (wavelength 282–320 nm).

The study of plant morphogenesis generally aims to elicit the processes by which light is absorbed and by which morphogenetic responses occur. Plants have the ability to utilize their information gathering capacity to sense the light environment. They also tune, their by their adaptive senses, morphogenic and developmental program to the same light qualities, blue and red wavelengths to be utilized by the photosynthetic apparatus. In fact, a majority of the photomorphogenesis events occurring in plants is induced by blue or red/far-red signals through the three classes of photoreceptors. These photoreceptors perceive and interpret ambient light signals and transduce them to modulate plant growth and development. The light control of seedling development has been conveniently used as model for dissecting the signaling mechanisms of these photoreceptors.

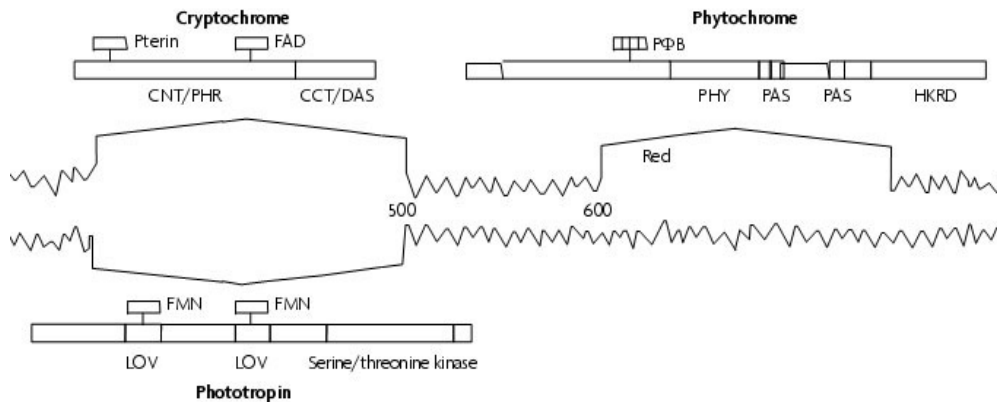
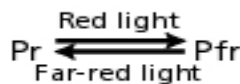

Figure 9 - light Signals and Photoreceptors.

Phytochromes

Phytochromes are a family of unique photosensory molecules used by plants to monitor informational light signals in the environment. The phytochromes are red/far-red light-absorbing photoreceptors Borthwick et al. (1952) discovered presence of phytochrome(s) in plants. The results of their stunning now classic finding suggested that light-regulated seed germination in lettuce (*Lactuca sativa*) operates through a red/far-red photoreversible process. This unique photosensing feature greatly facilitated all subsequent physical characterization of phytochrome(s) and the photobiology that they control. Studies on the phytochromes has continued to advance, over the time, through the exploitation of technological achievements in several areas including spectroscopy, biochemical purification, immunochemistry, molecular genetics, genetic engineering



of plants and now reverse genetics. The phytochrome family consists of five members [Phytochrome A (Phy A) to Phytochrome E]. The phytochromes can exist in two spectrally distinct forms, (i.e. Pr and Pfr). Red light activates phytochrome by converting it from the Pr form to Pfr form.

Conversely, far-red light inactivates phytochrome by converting Pfr to Pr. This photoconvertible nature of phytochromes enables plant to monitor the ratio of red to far-red light which is greatly reduced in the shade. The phytochromes have the capacity to undergo light-induced, reversible interconversion between two forms: Pr, which absorbs red Photons most efficiently (λ_{max} , 665 nm) and Pfr, which absorbs far red (FR) photons most efficiently (λ_{max} , 730 nm). Light-triggered Pfr formation (Signal perception) initiates a transduction process which culminates in the altered expression of selected genes that are responsible for directing morphogenesis for the prevailing conditions.

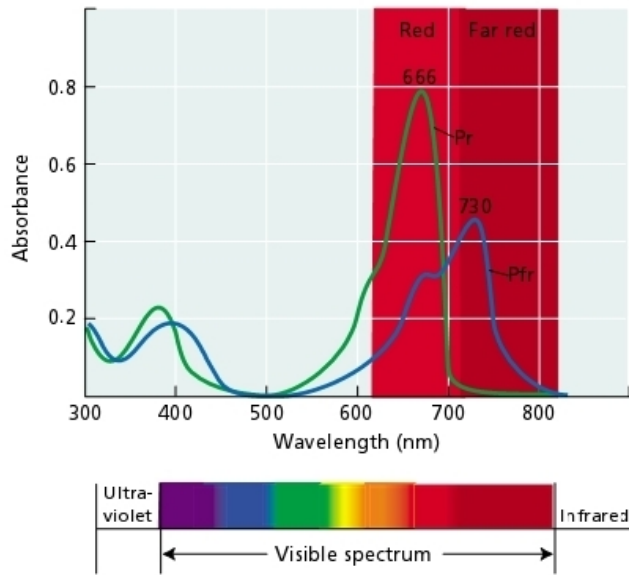

Figure 10 -Absorption spectra of purified oat phytochrome in the Pr (green line) and Pfr (blue line) forms overlap.

In higher plants, the phytochromes are encoded by a gene family (PHYA–E). These constitute two distinct pools, denoted Type I and Type II. The Type I phytochrome is more abundant in etiolated tissues. This type is light labile and exhibits rapid degradation and/or sequestration of Pfr. Conversely Type–II is present in much lower amount in dark–grown tissue but is light stable. As a consequence, Type I phytochrome is more important for the initial de–etiolation process, whilst type II response predominates in mature tissues/plants. The phytochrome A (Phy A) is a Type–I phytochrome, as it is synthesized in the dark and removed rapidly in the light. Phytochromes B to E (PHY B–E) are light stable and probably constitute the Type II pool.

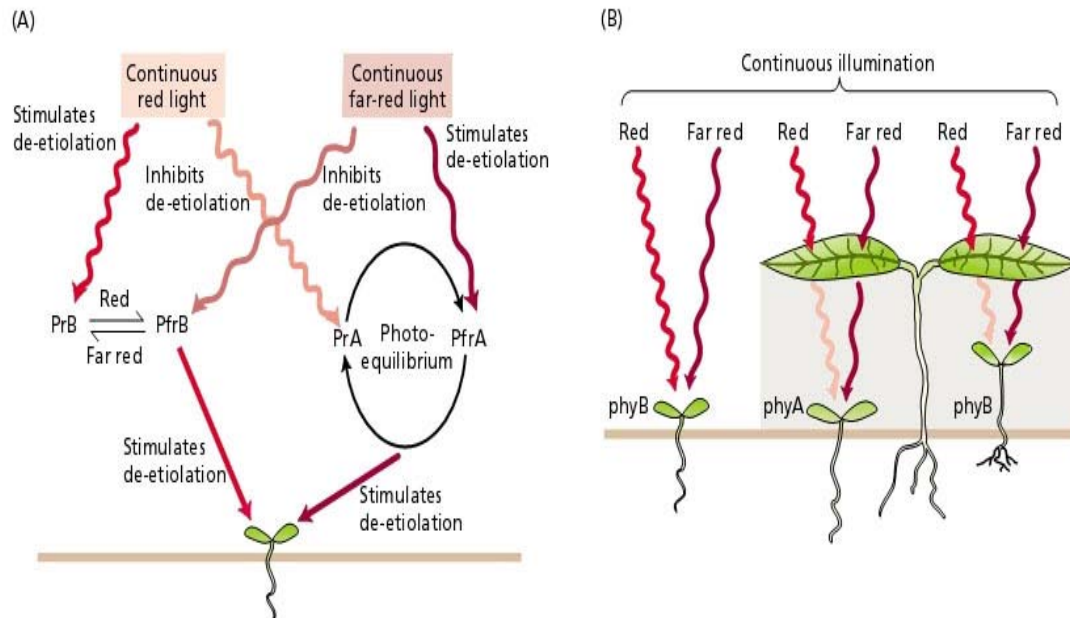

Figure 11 - Mutually antagonistic role of phy A and phy B.

Molecular properties of phytochromes

Higher plant phytochromes are a soluble homodimers of subunits (polypeptides) of about 120/125 kilodaltons (kDa) each of which folds into two major structural domains: an NH₂-terminal domain, which cradles a single, covalently attached tetrapyrrole chromophore, and a COOH-terminal domain, which mediates dimerization. The N-terminal half is required for spectral integrity, whereas the C-terminal half mediates dimerization and interactions with signaling partners. Phytochromes are chromoproteins composed of about 1100 amino-acid residues and one linear tetrapyrrole chromophore (Phytochromobilin).

Light activation of these phytochromes induces a broad range of photomorphogenetic responses such as seed germination, de-etiolation (greening) and floral induction, working synergistically and antagonistically. With recent genomic developments, the known occurrence of phytochromes has been extended to include many prokaryotic organisms with bacteriophytochromes. Two major members of the phytochrome family, Phy A and Phy B, have been well studied with regard to their primary structure function relationship. These molecules consist of two functional domains, 70-Kda N-terminal photosensory domain and 55-Kda C-terminal regulatory domain, composed of functional subdomain and segments. The photosensory region includes the bilin lyase domain (BLD) for light sensing and induces the reversible phototransformation. In the BLD, a 6-Kda N-terminal extension segment (ATS) exhibits, α -helical folding in the Pr-to-Pfr transformation, stabilizing the conformation of Pfr and enabling physiological functions. The primary structures of BLD are well conserved among Phy A to Phy E. Part of the BLD including bilin-binding cysteine is expected to have similar tertiary structure to GAF domain found in hundreds of signaling and sensory proteins. The C-terminal portion next to the GAF domain in the photosensory region is named the phytochrome (PHY) domain. This is requisite to keep the absorption spectra intact. The regulatory region consists of two PAS (Per/Arnt/Sim) - Related domain (PRD) and one histidine-kinase-related domain (HKRD).

The HKRD is now considered to be a histidine-kinase parologue with Serine-Threonine kinase specificity in contrast with the histidine kinase function of bacteriophytochromes. Within the PRD a cluster of amino-acid

residues named the Quail–box (QB) is essential for signal transduction in both Phy A and Phy B. The HKRD is overlapped by the nuclear–localization signals (NLS) which is involved in nuclear import of Phy A which was first observed with Phy B.

Phytochrome–mediated physiological responses

The classical phytochrome–mediated response is activated by a single short pulse of red light and is reversed by a subsequent exposure to far–red light. Such phytochrome responses have been divided into different classes based on the radiation energy of light that is required to obtain the response. These include low fluency responses (LFRs), very low fluency responses (VLFRs) and high irradiance responses (HIRs). The fluence requirement is 1–1000 $\mu\text{mol}/\text{m}^2$ for LFRs; 0.0001 – 0.1 $\mu\text{mol}/\text{m}^2$ (100 pmol/ m^2 to 100 nmol/ m^2) for VLFRs and more than 1000 $\mu\text{mol}/\text{m}^2$ for HIR. HIRs are further divided into red–light and far–red light mediated HIRs. LFRs are the classical phytochrome responses with R/FR reversibility VLFR are not reversible and are sensitive to a broad spectrum of light between 300 nm to 780 nm. HIRs require prolonged or high frequency intermittent illuminations and usually are dependent on the fluence rate of light. Genetic studies of *Arabidopsis* phytochrome mutants have demonstrated that Type I phytochrome Phy A is responsible for the VLFR and the FR–HIR and that Phy B, the prominent Type II phytochrome is responsible for the LFR and R–HIR during photomorphogenesis.

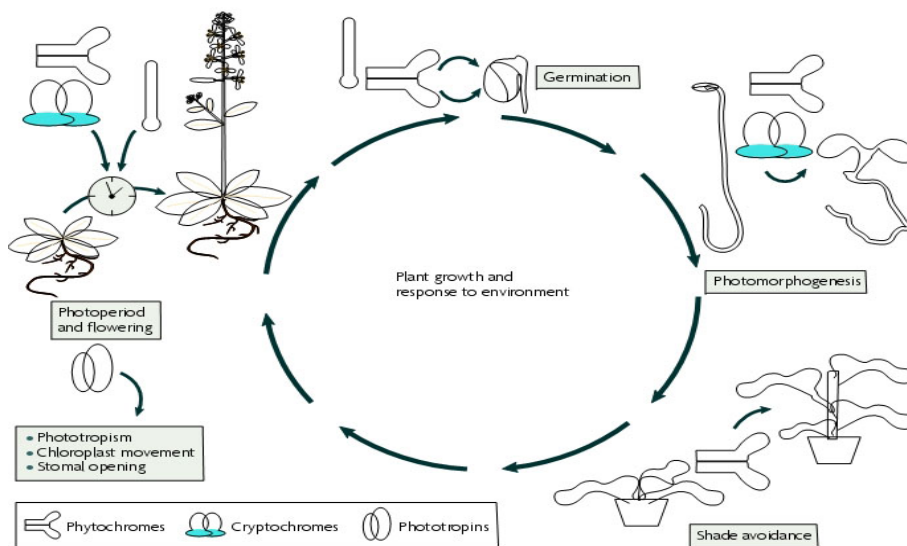

Figure 12 -light-regulated plant development.

Localization and function of phytochromes

Higher plant phytochromes are serine/Threonine kinases. Phy A undergoes autophosphorylation which is down–regulated by attachment with chromophore and enhanced by R light. Recombinant Phy A, also phosphorylates a number of proteins *in vitro*, including PKS 1 (PROTEIN KINASE SUBSTRAT 1), Aux/IAA, Cry 1 and Cry 2.

The discovery of light regulated translocation of phytochromes from the cytoplasm to the nucleus is one of the breakthroughs in phytochrome research. In *Arabidopsis*, all five phytochromes accumulate in the cytoplasm in the dark and translocate into the nucleus in a light–dependent manner. A Pr to Pfr conformational change is prerequisite for nuclear import. The light quality requirements and nuclear import kinetics are different for each of the different phytochromes. Phy A translocates in the nucleus in FR. All

five phytochromes accumulate in the nucleus in R or white light. The nuclear import of Phy A is much faster than that of PhB/C/DE. Only a fraction of phytochrome molecules localize to the nucleus in the light. In the nucleus, phytochromes compartmentalize to discrete small dot-like sub-nuclear foci.

Phytochrome Signaling

Genetic studies have identified both shared and separate downstream components of Phy A and Phy B pathways. Phytochrome-interacting proteins are now identified and characterized. Phytochromes function in both the cytosol and the nucleus. Pharmacological studies have suggested that heterotrimeric G Protein, cGMP, Calcium and calmodulin are early components in phytochrome signaling. A number of Phy A signaling intermediates have been localized to the cytosol or in organelles. The best-characterized cytoplasmic phytochrome signaling component is PKS 1. PKS1 interacts with the HKRD of both Phy A and Phy B. Both PKS1 and PKS2 are required for normal Phy A signaling in particular during VLFR conditions.

Global gene expression studies have shown that Phytochrome responses are associated with massive alterations in gene expression. Molecular mechanisms exist that suggest direct bridging phytochromes to transcription regulation. Regulation of protein degradation is an integral part of phytochrome signaling mechanism. Phy A undergoes COP1-dependent ubiquitin-mediated degradation in the light, which serves as a desensitizing mechanism for Phy A function. The levels of Phy B–E are also slightly down-regulated by light.

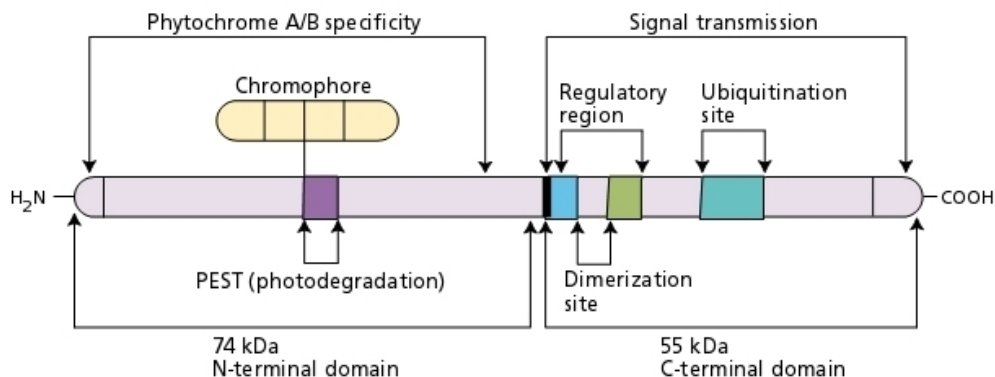

Figure 13 - Schematic diagram of the phytochrome holoprotein, showing the various functional domains. The chromophore-binding site and PEST sequence are located in the N-terminal domain, which confers photosensory specificity to the molecule—that is, whether it responds to continuous red or far-red light. The C-terminal domain contains a dimerization site, a ubiquitination site, and a regulatory region. The C-terminal domain transmits signals to proteins that act downstream of phytochrome.

Signal integration:

A number of light responses are mediated by the coordinated action of several photoreceptors. Phototropism and chloroplast movement are primarily controlled by the phototropins, but the amplitude of the response is modulated by both the phytochromes and cryptochromes. Seedling establishment, entrainment of the circadian clock, and photoperiod-induced flowering are controlled by the combined action of phytochromes and the cryptochromes.

Cryptochromes: Blue Light Receptors for Plants

Cryptochromes are blue, ultraviolet–A photoreceptors. They appear to be ubiquitous in the plant kingdom. They were first characterized for *Arabidopsis* and are also found in ferns and algae. In an early description of a biological response to blue light, Charles Darwin noted that the heliotropic movements of plants was eliminated if the light was first filtered through a solution of potassium dichromate. It is now realized that this ability to sense and respond to blue light (400 to 500 nm) is widespread throughout the biological kingdom. Other examples of such responses include the production of anthocyanins and carotenoids in plants.

and fungi and the entrainment of behavioral rhythms in flies and mammals. The action spectrum of many responses to blue light is similar to the absorption spectrum of flavin which prompted A.W. Galston (1950) to postulate the involvement of a flavoprotein. The nature of this photoreceptor remained debated for several decades. The elusive nature of this photoreceptor gave rise to the name cryptochrome (Gressel, 1979).

The Cryptochromes are very important during de-eliolation, the transition of a dark growing seedling living from its seed reserves to a photoautotrophically competent seedling. This developmental transition includes a massive reorganization of the transcriptional program, inhibition of hypocotyls growth, promotion of cotyledon expansion and synthesis of a number of pigments including chlorophyll and anthocyanins. This class of photoreceptors is also important for photoperiod dependent flowering induction and in resetting the circadian oscillator. The cryptochromes act in coordination with the phytochromes in numerous instances.

Arabidopsis has two cryptochromes, Cry 1 and Cry 2 with known function and a more divergent family member, Cry 3 for which there is no known function. Cry 1 is the primary photoreceptor under high blue light fluence rates, whereas Cry 2 is most important under low blue light fluence rates.

The cryptochromes are structurally related to DNA photolyases, but they do not possess DNA photolyase activity. The cryptochromes have an amino-terminal photolyase homology region (PHR) noncovalently binding a primary/catalytic FAD chromophore (Flavin Adenine Dinucleotide) and a second light-harvesting chromophore, a pterin or deazaflavin. Most plant cryptochromes have a distinctive carboxyl-terminal domain. They are of variable length but they share short stretches of homology among the plant cryptochromes. Cry 3 differs from Cry 1 and Cry 2 and is most closely related to the recently identified cryptochrome of cyanobacteria. It has no carboxyl-terminal domain extension but has a transient peptide sequence targeting it to both chloroplasts and mitochondria.

The isolation of mutants deficient in cryptochromes 1 and 2 (Cry 1 and Cry 2) has revealed roles for these photoreceptors throughout seedling development.

A mechanism of light action was proposed for cryptochromes based on the light activation of DNA-Photolyases. Existence of an electron-transfer reaction involving FAD is suggested for action of Cry 1. The cryptochromes also undergo light-regulated photochemistry. It is expected that they also bind to DNA. This has been demonstrated for *Arabidopsis* Cry 3 and Cry-DASH, its homolog in *Synechocystis*. Cry 1 and Cry 2 are nuclear. Cry 1 is mainly nuclear in the dark but predominantly cytoplasmic in the light. Cry 3 is present in both the chloroplast and the mitochondria. Both CRY 1 and CRY 2 expression are under circadian control. Cry 2 and Phy A have similar profiles and are light labile. Light-regulated protein degradation appears to be central cryptochrome signaling. The cryptochromes also interact with a number of other proteins. They directly interact with the phytochromes.

Phase change and timing of developmental transitions in plants

All organisms progress through a series of distinct developmental phases during their growth. In higher animals, each phase represents a different event in the life of a single organism. In higher plants, on the other hand, these developmental phases are episodes in the life of a part of an organism, the shoot apex. Plants undergo several developmental transitions during their life cycle. The shoot apex of higher plants passes through three more or less distinct phases during its post-embryonic development (a) a juvenile vegetative phase where it is not competent to flower (b) an adult vegetative phase where it can respond to floral inductive signals and (c) with the transition to flowering the plant enters the reproductive phase. Meiosis marks the transition to the gametophytic phase, and fusion of the gametes during fertilization starts the embryonic of the next generation. The juvenile phase of shoot development starts when the shoot meristem begins to initiate a stem, true leaves, and axillary buds. This phase may last for a few days or many years in different species and is distinguished by a variety of unique vegetative traits. The adult vegetative that follows juvenile phase is characterized by a different set of vegetative traits.

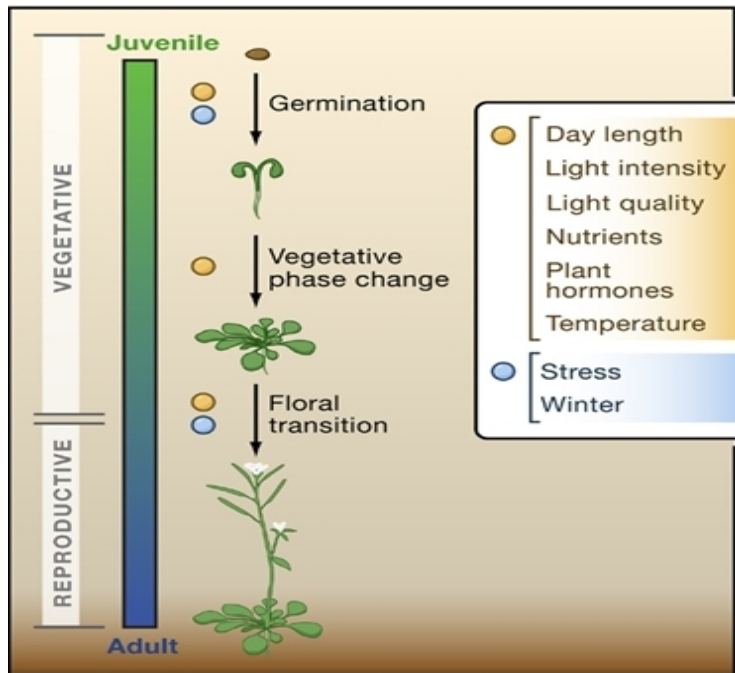

Figure 14- Developmental Transitions During The Plant Life Cycle.

The transformation of the shoot apex into a reproductive structure, such as inflorescence, flower, or cone, marks the end of its growth and involves particularly dramatic changes in its differentiation. In some plants reproduction is the last phase in the life of the shoot; in other types of plants the growth of the shoot is perpetuated by a lateral vegetative meristem after the terminal meristem becomes reproductive, whereas in some species primary meristem remains permanently vegetative and only lateral shoots form reproductive structures. Even within the reproductive phase, position related transitions can occur, such as a change in flower form. Many of these transitions are regulated by environmental cues to align development with favorable environmental conditions, thereby ensuring and maximizing reproductive success.

Regulation of Flowering

One of the most plastic developmental decisions in the life cycle of plants is the timing of the floral transition. To achieve reproductive success, plants must select the most favorable season to initiate reproductive development. This selection requires the existence of molecular mechanisms to continuously monitor environmental factors to properly respond to the adequate conditions. Many environmental factors influence flowering time. Those ranging in a predictable fashion along the year, such as light and temperature, are the most relevant in terms of the selection of flowering season. These predictable factors show complex patterns of variations and interaction in different temporal range (i.e. diurnal versus annual variation in light and temperature). However, even less predictable factors such as nutrient or wind can also

modulate flowering time, depending on species. Environmental factors display patterns of variation in the short (i.e. diurnal variation) and long ranges (i.e. seasonal annual fluctuation). Plants are able to perceive all this environmental variation and modulate their growth and development with responses that can be in the short term such as growth response to ambient temperature or in long terms like the flowering response to vernalization.

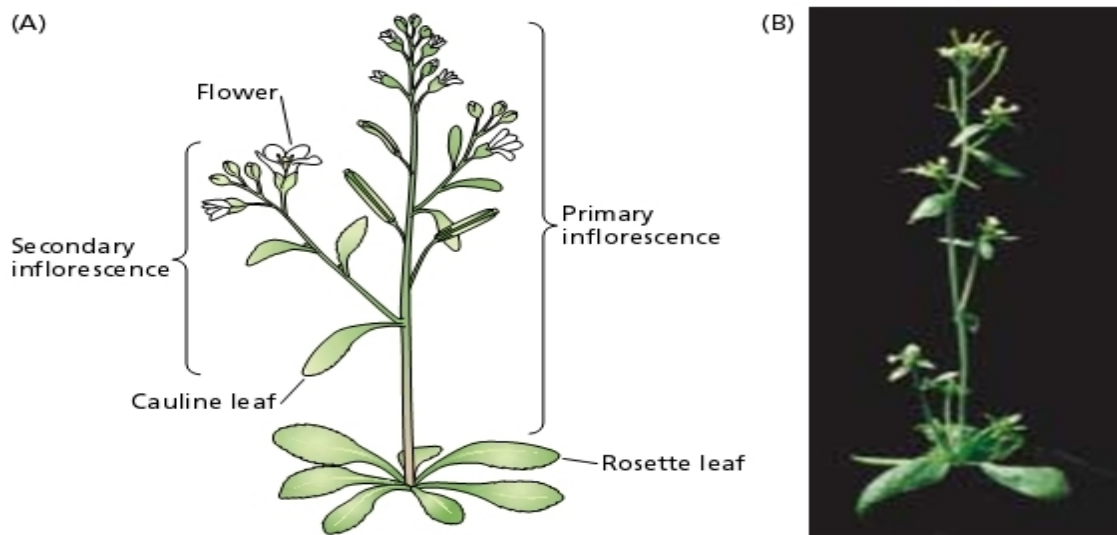

Figure 15- (A) The shoot apical meristem in *Arabidopsis thaliana* generates different organs at different stages of development .early in development the shoot apical meristem forms a rosette of basal leaves. When the plant makes the transition to flowering, the shoot apical meristem is transformed into primary inflorescence meristem that ultimately produces an elongated stem bearing flowers leaf primordia initiated prior to the floral transition becomes cauline leaves ,and secondary inflorescence develop in the axil of the cauline leaves.(B) Photograph of *Arabidopsis thaliana*.

Physiological control of flowering time



Figure 16 - Juvenile and adult forms of ivy (*Hedera helix*). The juvenile form has lobed palmate leaves arranged alternately, a climbing growth habit ,and no flowers.the adult form(projecting out to the right) has entire ovate leaves arranged in spirals ,an upright growth habit, and flowers.

In the natural temperature regimes, many factors in the environment influence flowering time. These factors are either predictable or not predictable, and hence can or cannot be used reliably by plants to time their reproduction. Factors that are highly predictable are considered to be the most specific or ‘primary’ controlling factors; these include the annual change in day length and the period of winter cold. Less predictable climatic factors, such as ambient temperature, light integral (day length x irradiance) and water availability, are usually viewed as ‘secondary’ factors that can modulate the effects of primary factors.

Finally unpredictable or ‘tertiary’ factors are those that the plant has to face locally, such as mineral availability, wind and neighbors. The effects of neighborhood have some times have limited to the response to light quality, although they also involve competition for light, water and minerals.

Organs involved in environmental perception:

Environmental factors participating in the control of flowering time are not all perceived by the same organ(s). Vernalization is generally perceived by the shoot apex [shoot apical meristem (SAM) plus leaf primordia]. Day length and light quality are usually believed to be essentially perceived by expanded leaves but, in the absence of leaves, they can also be perceived by the stem. Thus, all aerial organs participate in the perception of day length and light quality. Ambient temperature is also sensed by all plant parts including the roots water and minerals availability are perceived by the roots. Roots ‘hidden half of the plant’ have been found in some studies to promote or inhibit flowering depending on the species and environmental conditions.

Figure 17 - Four developmental pathways for flowering in *Arabidopsis*; the photoperiodism, autonomous /vernalization, sucrose and Gibberellin pathways. A transmissible floral stimulus (“florigen”) from leaves is only involved in the photoperiodic pathway.

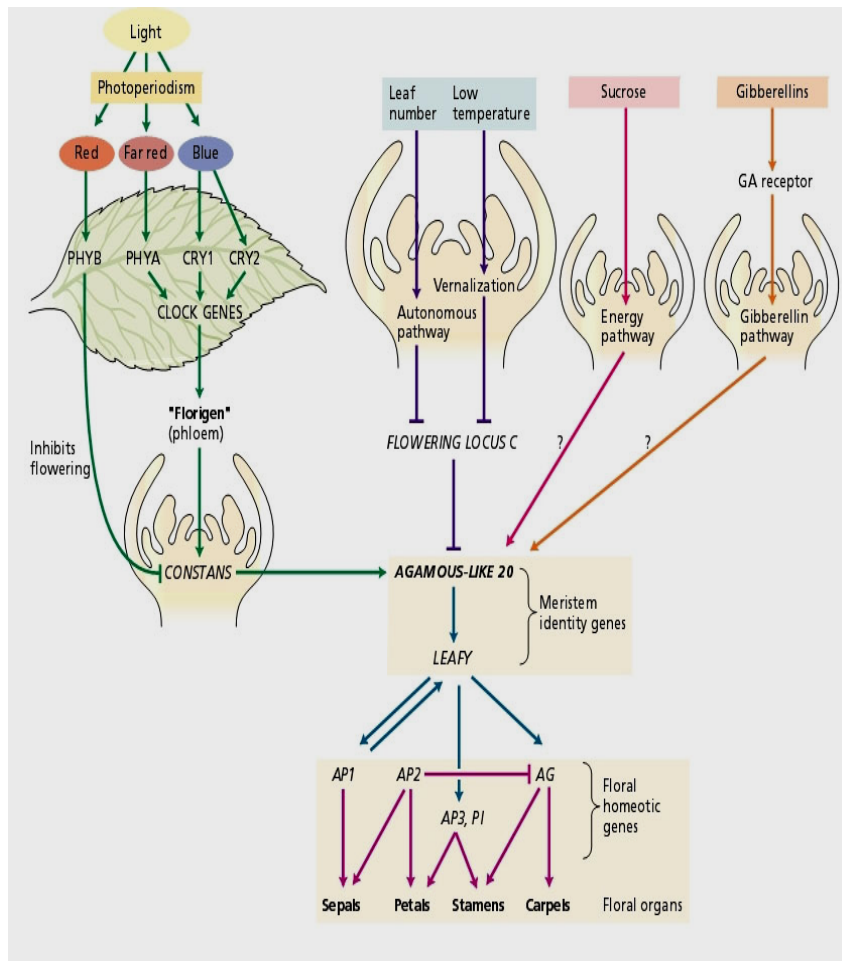

Endogenous Cues

Flowering time in plants is also influenced by endogenous cues such as size, node number or age. Size rather than age was demonstrated to be particularly important in biennials, as well as in long-lived monocarps, in polycarps with long-lived monocarpic ramets and other polycarps. Biennials generally flower during their second year of growth when they are cultivated in resource-rich conditions, such as agricultural fields, gardens and experimental growth areas. In natural environment, they flower only during their third or fourth year or even later. These should then be called “delayed” biennials or, more appropriately “monocarpic perennials”. Many field studies have revealed that the best predictor of flowering onset in these plants is the reaching of a threshold size, although this threshold may vary greatly amongst species and ecotypes. This conclusion is in line with physiological observation showing that partial or complete removal of foliage, i.e. plant trimming may decrease or even abolish the response of many plants to vernalization or favorable day lengths. Also size is directly related to the amount of resources accumulated, and thus depends on the ambient temperature, irradiance, water/mineral availability and presence/absence of neighbors. In other words, in natural environments in which many factors are far from optimal, secondary and tertiary factors are often predominant over the primary factors for the control of flowering time. By contrast flowering in natural population of annuals is often principally controlled by primary environmental cue(s) such as day length, and occurs independently of size and age.

Long distance Signals: Although the fact that most plant parts participate in the sensing of the environmental factors that control flowering time clearly indicates that inter-organ, long-distance signaling must be involved in the triggering of flowering of the SAM, most of the physiological work to date has favored the study of the unidirectional signaling event linking, in photoperiodic plants, the leaves to the SAM. The leaf-to-SAM signal is called ‘florigen’ when the leaves are exposed to day length favorable to flowering and ‘antiflorigen’ when the leaves are exposed to day lengths unfavorable to flowering. Numerous grafting experiments have shown the movement of such signals in several plant species, but progress in identifying them has been extremely slow. Recently several groups have recorded successfully the identification of “florigen(s)” the molecules that are synthesized in response to appropriate photoperiod and transmitted from leaves to SAM to promote floral initiation.

In *Arabidopsis*, cryptochromes and phytochromes mediate long-day promotion of CO protein expression, which activates FT mRNA expression in leaves. FT mRNA is transmitted to the shoot apex, where it acts together with FD to activate transcription of floral meristem identity genes, resulting in floral initiation. The discovery of molecular nature of a florigen was major scientific breakthrough in 2005.

Genetic control of flowering time

Genetic and physiological analysis of flowering time in *Arabidopsis* has led to the identification of large number of flowering-time genes (more than 780) that regulate flowering time in response to environmental and endogenous cues. Various genetic and molecular approaches have suggested that there are four major genetic pathways involved in the regulation of key floral regulatory genes (Phase transition) in *Arabidopsis*. These include (i) photoperiod-dependent, (ii) vernalization, (iii) gibberellic acid (GA), and autonomous pathways. The two main pathways: the long-day (photoperiod-dependent) and vernalization mediate through environmental cues/responses. The other two pathways function independently of environmental cues. The autonomous pathway promote flowering under all conditions, and the gibberellin’s pathway is needed for flowering under non-inductive short-day conditions. Regulation of flowering occurs through a complex network of genetic pathways. These pathways converge in the induction of floral meristem identity genes and the floral initiation. A large number genes acting within these pathways have been cloned and analyzed. Two genes play a prominent role in the “bottom” of these promotion cascades. The CONSTANS (CO) gene is probably the most downstream actor; specific for photoperiod (the long-day) pathway and both the light and internal clock precisely regulate the CO protein accumulation. The FLOWERING LOCUS C (FLC) gene is the point of convergence of the autonomous and vernalization pathways. Ultimately and in part through CO and FLC, the flowering signals lead to the induction of a set of genes called floral meristem identity (FMI) genes and responsible for the fate change of the meristems emerging on the flanks of the shoot apex. This group of genes includes LEAFY (LFY), APETALA 1 (AP 1) and CAULIFLOWER (CAL), expressed in early floral stages and responsible for their floral fate. Recently, three genes were shown to make the junction between the different flowering-time cascades and FMI genes. These genes were named Floral Pathway Integrators because they are able to integrate a balance of stimulations originating from different pathways and convert these heterogeneous inputs into an induction of FMI genes, thereby initiating the production of the first floral meristems. The three genes shown to integrate the influence from different pathways are LFY, FLOWERING LOCUS T (FT) and SUPPRESSOR OF CO OVER EXPRESSION (SOC 1)/ AGAMOUS-like 20 (AGL 20).

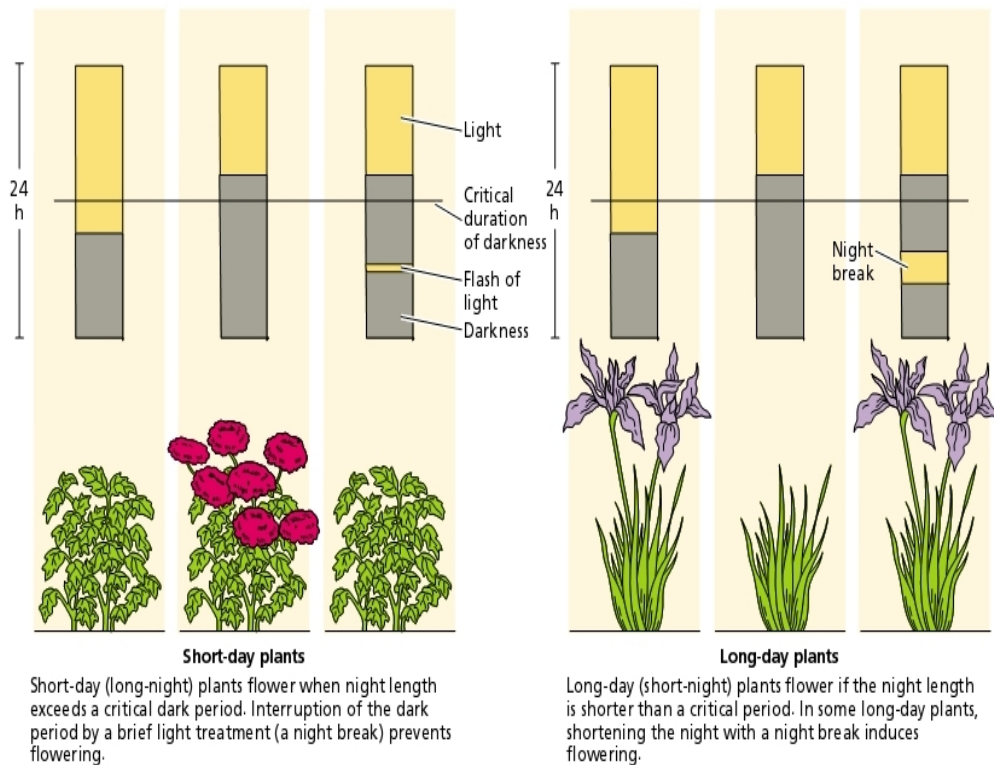

Figure 18

The beauty and complexity of flowers have fascinated the scientists for centuries, from Linnaeus, to Goethe, to Darwin, through to the present. One of the unifying theories of plant biology is that the variety of plant forms is simply different modifications of a common growth plan. Different permutations of a few key features of plant growth can generate an array of seemingly distinct forms. The comparison of a flower and a shoot is one of the best illustrative examples. Goethe's treatise on metamorphosis published in 1790, suggested the idea that these two apparently different structures might be fundamentally equivalent. Goethe concluded, "Flowers which develop from lateral buds are to be regarded as entire plants, which are set in the mother plant, as the mother plant is set in the earth" (Goethe, 1790). In equating flowers and shoots four key assertions need to be made. First, the different parts of the flower (sepals, petals, stamens and carpels) are equivalent to the leaves of a shoot. Second, the organs of both shoot and flowers are separated by internodes, but in the case of flowers these are so short as to be barely visible. Third, the organs of shoot and flower usually have a distinct phyllotaxy, or arrangement around the central axis. Finally, the intermediate growth that characterizes a shoot is suppressed in the case of a flower, both apically (because it eventually stops producing organs around the central axis) and laterally (because branches do not normally arise in the axils of floral organs).

Physiology of Flowering

The main turning point in the life of lower/higher plant is the transition to flowering, on which they embark a different times ranging from several days after the outset of germination in miniature ephemerals to many decades in giants of the plant kingdom. The transition to flowering is a result of functional activity and interaction of all vegetative organs and is realized in the plant as an integral organism. The transition from vegetative growth to reproductive growth (flower formation) is caused by internal factors.

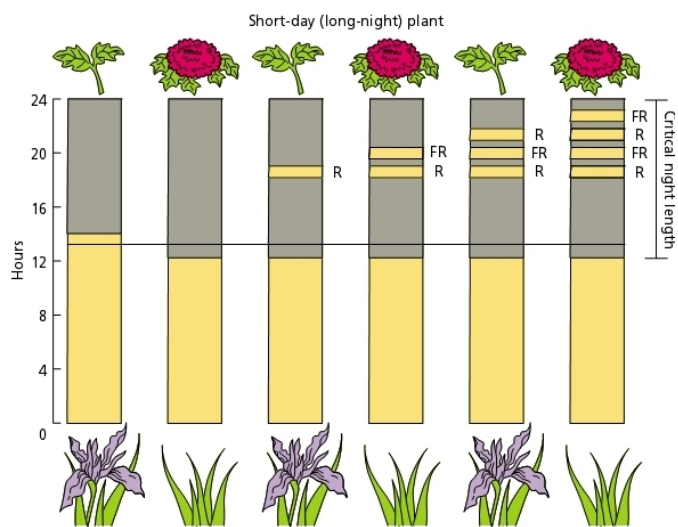

Figure 19 - Phytochrome control of Flowering by red (R) and far-red (FR) light. A flash of red light during the dark period induces flowering in an LPD, and the effects is reversed by a flash of the far-red light .this response indicates the involvement of phytochrome. In SPD s, a flash of red light prevents flowering, and the effect is reversed by a flash of far-red light.

Goethe (1798) submitted the morphological picture of emergence of the flower as a modified leaf .This strengthened the conceptions interpreting the physiological nature of changes that precede the transition of plants from vegetative growth to flowering. J. Sachs (1880) put forward the hypothesis of specific flower-forming substances. This remained as an original guess capable of agitating the imaginations of scientists and readers. Klebs (1913, 1918) proposed the theory of flowering and suggested that nutritive substances (Carbohydrates) manufactured during photosynthesis and nitrogenous compounds acquired through the roots are of decisive significance in the flowering plants. This theory was supported by (i) a number of investigators and (ii) as well as in practical horticulture and floriculture in connection with use of fertilizers and methods involving training and girdling of fruit plants. After 57 years, the conjecture of Sachs became embodied in the hormonal conception of plant flowering proposed by M. Kh. Chaila Khyan (1937). Meanwhile, the idea of Klebs as to significance of photosynthesis and the ratio of carbohydrates and nitrogenous compounds (C/N) turned out to be fruitful. It was clarified that photoperiodism (i.e., the response of plant flowering to day length) is closely associated photosynthesis, while the C/N ratio is applicable as a means of characterizing the overall direction of metabolism, viz., predominance of carbohydrates for long-day species and pre-dominance of nitrogenous compounds for short-day species. It became possible to generalize the results of investigations emanating from the Sachs hypothesis and Klebs theory, and to verify the significance of both hormonal and trophic factors in the generative development/flowering of plants.

The discovery of photoperiodism played a prominent role in the development of knowledge about the physiological nature of flowering, since biotypes were clarified that flowered in the presence of wide ranges of rations of light and dark periods of the day, such biotypes belonged to the main photoperiodic groups, viz. short-day, long-day and day neutral plants. Subsequently a concept was formulated that suggested that flowering of all annual seed plants occurs in two phases: (1) The phase of formation of flower stems, influenced by intensified carbohydrate metabolism and enhanced content of gibberellins and auxins; and (2) the phase of flower formation, affected by the presence of increased metabolism of nitrogenous compounds and heightened content of substances of the anthesin type. Hormonal regulation of flowering is based not only on stimulation of flowering caused by stimulating substances, but also on inhibition of flowering determined by natural substances that retard flowering. Thus, the effect of hormonal regulation in all cases is the balanced result of simultaneous action of stimulants and inhibitors.

Metabolism and translocation of substances that affect regulation of plant flowering are associated with formative processes that occur in organs that interact with each other. The transition to flowering in different biotypes of higher plants sets in after passage of the juvenile phase/state, in which the vegetative organs are formed in

seedlings and they acquire the capacity for perception of the action of environmental factors and interaction of organs determining advance to the flowering state.

Photoperiodically sensitive flowering can be differentiated into two phases, viz. leaf induction or photoperiodic induction proper and stem induction or evocation (commitment/determination) of flowering. In photoperiodically neutral species (in contrast to photoperiodically sensitive ones), the transition to flowering is not differentiated into two successive phases occurring first in the leaves and then in the stem buds, but rather takes place simultaneously in leaves and stem along the main axis of the stem in conformity with a physiological gradient depending predominantly upon age changes.

It follows that age regulation leading to evocation of flowering is manifested in these species instead of photoperiodic regulation.

Induction of flowering:

Induction of flowering is of two types (1) ecological, i.e. associated with influence of major environmental factors; and (2) endogenous, i.e. associated with age changes. Among environmental factors that create the ecological setting, light and temperature, exert the strongest influence on flowering of plants. Thus, the types of induction include photoperiodic induction, light induction (based on influence of the intensity and quality of light), temperature induction, thermoperiodic induction, and others. Photoperiodic induction is the most pronounced type. Endogenous induction also transpires under definitive environmental conditions. However, age changes are of dominant significance. Such changes result in the emergence of a flowering state gradient along the main axis of the stem. Age induction is most pronounced in photoperiodically neutral species.

Photoperiodic induction

Photoperiodic induction is composed of processes that begin in the receptor organ (leaves) and end in stem buds (Chailakhyan, 1982). These processes have a hormonal nature and are associated with the formation of two groups of flowering hormones, viz. gibberellins (which affect formation of flower stems) and anthesins (which influence formation of flowers). Formation of a complex of these flowering hormones (the florigen) during the process of induction proceeds differently in short-day species and long-day species. In short-day species (which constantly contain gibberellins), induction under short days is associated with the formation in leaves of anthesins, which are transported to stem bud, where they combine with gibberellins and form a biocomponent hormonal complex, the florigen. In long-day species (which constantly contain anthesins), induction under long days is associated with the formation of gibberellins, which are transported to stem bud, combine with anthesins in it, and form a biocomponent hormonal complex, the florigen.

A biocomponental hormonal complex (the florigen) arises in apices of the plants in both biotypes the SDPs/LDPs. The available proofs are different in regard to the two groups of flowering hormones comprising the florigen complex. In regard to gibberellins, their nature, biosynthesis and mode of action/function as regulator hormones has been experimentally demonstrated in the induction of flowering of many plant species.

However, the chemical nature and structure of anthesins are unknown and idea about them is based on numerous data obtained in testing biological responses.

In addition to gibberellins and anthesins other phytohormones and physiologically active compounds also take part in induction of flowering. Several authors felt that the entire complex of already known phytohormones is responsible for the transition of plants to flowering. However, the cases of induction of flowering in plants under the influence of auxins, cytokinins, ethylene producers, and abscisic acid do not play the part of basic flowering regulators, but rather act as components of the hormonal system that influence flowering cooperatively together with the main flowering hormones.

Putative mobile signals that regulate flowering

The existence of long-distance signals of flowering has been known for several decades. Different molecules have been proposed as components of the floral stimulus and inhibitors, but there is no conclusive proof so far that any of them is the flowering signal transmitted from leaves to the shoot apical meristem. The main compounds postulated as graft-transmissible floral regulators are — Gibberellins, Cytokinins, sucrose, proteins and peptides, salicylic acid, brassinosteroids, nitrogenous compounds including amino acids (glutamine and asparagines) and polyamines.

Several plant hormones are thought to regulate flowering by moving from leaves to the shoot apex, based mainly on two approaches: the effect of mutation in genes affecting hormone synthesis or hormone signal transduction on flowering and the effect of exogenous applications of hormones or hormone inhibitors on flowering. Only for gibberellins (GAs) and cytokinins there is sufficient experimental evidence. The effect of GAs on flowering has been extensively reviewed. Gases are present in phloem and xylem saps indicating that they can be transported. In *Arabidopsis*, Gas promote flowering, especially under short-day conditions. In several LD and SD species GAs do not induce flowering unless accompanied by other treatments and in others, Gas inhibit flowering. The role of GAs as floral stimulus is best documented in *Lolium temulentum*. Several species can be induced to flower by exogenous cytokinins, but in most cases only when the treatment is combined with other factors inductive for flowering.

Other growth hormones can either inhibit or promote flowering. Ethylene and ethylene-releasing compounds promote flowering in Pineapple (*Ananas comosus*). This is one example of great commercial importance. This response appears to be restricted to members of the Pineapple family (*Bromeliaceae*). Recent studies have revealed that Amino-cyclopropane-1-carboxylate synthase (ACC synthase) cloned from pineapple (ACACSZ) is one of the key contributors towards triggering 'natural flowering' in mature pineapple under commercial conditions.

Age induction:

Age induction consists of processes all organs of the plant leaves, stems, and stem buds and associated with age changes. Flowering of photoperiodically neutral species depends upon age and is subordinate to the appearance of a physiological gradient. A stimulus arise in leaves and stems under conditions of any day length as a result of age changes occurring in accordance with a gradient along the main axis of the stem constitutes the generator of flowering in neutral species. Formation of hormones/florigen (gibberellins and anthesins) in photoperiodically neutral species occurs under conditions of any day length, while their distribution is accomplished on the basis of a gradient in the acropetal direction throughout the axis of the main stem. The formation of hormone (florigen) occurs slowly in the juvenile phase. This process undergoes intensification in plants in the maturity phase and florigen levels increase in stem buds.

Evocation (commitment/determination) :

The formation of flowering hormone (florigen) in stem buds mark the onset of process involved in evocation (commitment to flower) which leads to the formation of floral primordia. The physiological and structural changes of apices that occur during evocation of flowering exhibit a common nature in LDs, SDs and day-neutral plant species. Evocation is based on florigen-induced synthesis of specific mRNAs and formation of specific proteins which probably take part in initial structural changes leading eventually to floral organ formation. Evocation is the phase of regulation in which the genetic program of the vegetative direction of development is replaced by the genetic program of the generative direction of development. Floral morphogenesis at the shoot apical meristem is final stage of flowering.

Inhibition of flowering:

Flowering, like any other processes of development, is regulated not only by factors that induce and stimulate its initiation, but also by factors that retard it and cause its inhibition. Inhibitory factors can be both trophic substances and components of the hormonal system that exert inhibiting action on induction and retarding action on evocation of flowering. The inhibitory factors of flower induction are different for SDs, LDs and neutral plants. Conversely factors that retard evocation exhibit common nature. It has been hypothesized that a complex of substances that retard flowering (an antiflorigen complex) can be formed in plants.

Prevention of Flower Formation:

Knowledge of the genetic regulation of flower development provides possibilities to prevent flower formation with transgenic techniques. An inflorescence specific gene of Birch, BpMADS 1 has been isolated. Transgenic tobacco and *Arabidopsis* containing a construct of BpMADS 1 and the cytotoxin gene(s) BARBASE (BpMADS 1 : BARNASE) grew well. Some of these plants and their lines did not form inflorescence/flower but formed increased number of leaves and produced increased vegetative mass. Prevention of flower formation is important, for example for preventing the spread of transgenes from genetically modified plants or the spread of non-native species, for increasing vegetative growth or preventing the formation of allergenic pollen. The increased production of leaves in transgenic is interesting for many reasons, including the possibility of breeding medicinal plants, vegetables or plants used for fodder.

Photoperiodism:

Plants constantly monitor changes in their light environment in order to maximize photosynthetic rate (e.g. by phototropism and shade avoidance) and to appropriately regulate key developmental transitions (e.g. seed germination and the induction of flowering). Plants sense light quality, direction, quantity, and periodicity through phytochromes (which possess red and far-red absorbance maxima), cryptochromes and phototropins (which absorb blue-light) and UV-B photoreceptors (of unknown molecular nature).

Fluctuations in the length of day and night affect developmental processes and behavior of many organisms. The ability of an organism to detect day length is termed as photoperiodism. These phenomena allow detection of seasonal changes and anticipation of environmental conditions such as low temperature and desiccation. Circadian rhythms and photoperiodism have the common property of responding to cycles of light and darkness. Plant responses controlled by day length are the initiation of flowering, asexual reproduction, the formation of storage organs (like tubers of potato) and the onset of dormancy.

Photoperiodism was first described in detail by Garner and Allard in 1920 through the demonstration that many plants flower in response to change in day length. Subsequently they also showed that some plant species flower when day length falls below a critical day length, whereas other plants accelerate flowering in response to day length longer than a critical day length. These plants are called short (SD) and long day (LD) plants, respectively. Plant species that flower under any photoperiodic conditions are referred to as day-neutral plants (DNP). The discovery of photoperiodism played a prominent role in development of knowledge about the physiological nature of flowering.

Selection development and breeding of photoperiod-insensitive varieties has been major event in modern crop husbandry that led to green-revolution increased productivities of Wheat and Rice in Asia. Many desert plants evolved to germinate, grow, and flower quickly whenever sufficient water is available. These are also DNPs under natural conditions; plants monitor day length by measuring the length of the night. Primarily the duration of darkness determines flowering of SDPs and LDPs. The minimum dark period required for flowering, is made ineffective by interruption with a short exposure to light, called a night break (NB). However, interrupting a long day with a brief dark period does not cancel the effect of the long day. Flowering is effectively inhibited in many SDPs by night-break treatments of only a few minutes. In contrast longer exposures (night-break) are required to promote flowering in LDPs. The effect of night-break varies according to the time when it is given. It is most effective for SDPs and LDPs when given middle of a dark period of 16 hours. The discovery of the night-break effect established the central role of the dark period. This also provided valuable clue for studying, photoperiodic timekeeping. The discovery of this phenomenon has also led to the development of commercial methods for regulating the time of flowering in horticultural plant species.

The phenomenon of night-break (NB) has been extensively used as a tool to study the photoperiodic control of flowering. In rice (*Oryza sativa*), 10 minutes of light exposure in the middle of a 14-h night caused a clear delay in flowering. A single NB strongly suppressed the mRNA of Hdza, a homolog of *Arabidopsis thaliana* FLOWERING LOCUST (FT). The NB effect on Hdza mRNA was maximal in the middle of the 14-h night. The Phy B mutation abolished the NB effect on flowering and Hdza mRNA, indicating that the NB effect was mediated by the phytochrome B. These molecular genetic studies strongly suggested that the suppression of Hdza mRNA is the principal cause of NB effect on flowering in rice.

Erwin Bunning first proposed that the photoperiodic time-keeping mechanism is associated with circadian clock (Bunning, 1936) — an autonomous mechanism that generates biological rhythms with a period of approximately 24 hours. The control of flowering according to this model by photoperiodism is achieved by an oscillation of phases with different sensitivities to light. The light promotes or inhibits flowering depending upon on the phase of circadian rhythm in which light is given. When a light signal is administered during the light sensitive phase of the rhythm, the effect is either to promote flowering in LDPs or to prevent flowering in SDPs. This model is called the external coincidence model, has been supported by a number of physiological studies for the control of flowering time, indicating that the basis of day length measurement is the interaction of an external light signal with circadian rhythm. In contrast, another model called the internal coincidence model, proposes that the floral response occurs under conditions in which two differentially entrained (synchronized) rhythms are brought into same phase under day lengths that promote flowering, but that under other day lengths these two rhythms are out of phase. Studies of photoperiodism in insects support this model but details of analyses have not been carried out to test in plants.

Plants exhibit several adaptations for avoiding the ambiguity of day length signals. The photoperiodic responses are coupled with temperature requirements. Winter wheat does not respond to photoperiod until after a cold period (vernalization or over-wintering).

The Florigen Concept

The theory of hormonal regulation flowering was forwarded by Mikhail Khristoforovich Chailakhyan in 1936 in three consecutive publications. The publications of 1936 singled out plant organs that responded to day length and in this way distinguished between the photoperiod effects on leaves and shoots (shoot apices) by differential illumination of leaf blades and partially defoliated shoots. The plants flowered only in the case when leaves were treated to the favorable day length. These experiments led M.K. Chailakhyan to conclusion that “the processes that are evoked by the change in the day length and induce flowering take place in leaf tissues. Later, the effects of these processes are transmitted from leaves into shoot apices, and the latter are affected to proceed to flower formation. The author emphasized that “the transmittance of the day-length effect depended on some substances that could move for considerable distance along the stem”. These substances inducing flowering in shoots, or the floral stimulus, were given a short name of the florigen, that is, a flower formation agent. Florigen was shown to display activity in low quantity: in many plant species, the transition to flower occurred when a single leaf or even small portion of the single leaf was exposed to favorable day length. Plant girdling and excision of induced leaves following various time intervals after light induction demonstrated that the floral stimulus is transmitted, both acropetally and basipetally, along the stem cortex, most probably via the phloem elements. The stimulus can pass through a graft from flowering to non-induced components and promote flowering of the latter under unfavorable photoperiod. The grafts were also obtained between plants belonging to different species and diverse photoperiodic groups. This evidence led to the author to an important postulate: the floral stimulus (florigen) was not species-specific. Chailakhyan concluded that the floral stimulus florigen was of hormonal nature. Researchers found that florigen was not an auxin. The leaf phase of plant response to an external stimulus was called the induction (initiation) of flowering, and the subsequent response of the shoot apex, the evocation of flowering.

Florigen is self-propagating

In a number of plant species, the induced state seems to be self propagating. The young leaves that develop on the receptor plant after it has been induced to flower by a donor leaf can themselves be used as donor leaves in subsequent grafting experiments, even though these leaves have never been subjected to an inductive photoperiod. This phenomenon is called as indirect induction. Due to characteristic of indirect induction, the effect of florigen from the donor leaf remains constant even after serial grafting of new donors to several plants suggesting that the induced state is propagated throughout the plant. The floral stimulus is likely to be molecule that induces its own production in a positive feedback loop.

Florigen is physiologically not specific. It can be exchanged between short-day, long-day and day-neutral plants. It is very likely that it is identical in all plants. The main difference between short-day and long-day plants is that the florigen production occurs only under a certain (inductive) light program that differs in two types (biotypes).

Mutants have been isolated that are deficient in the floral stimulus (florigen). The detailed study of the activities of such phytohormones as gibberellins, cytokinins, auxins, and ethylene on flowering in diverse photoperiodic group led to the notion of (i) biphasic flowering process and (ii) two components of florigen comprising two complementary groups of phytohormones, gibberellin and anthesins. Gibberellin deficiency has been shown to prevent flowering in several long-day species. Gibberellins were reported to play important role in floral transition in plants belonging to various biotypes. As to second component of florigen, anthesins, Chailakhyan hypothesized, already in 1960, that anthesins would comprise specific nitrogenous compounds, including the metabolites of nucleic acids. The extracts from flowering tobacco plants were found to produce an anthesin-like physiological effect; they made short-day plant species shift to flowering under the long-day conditions. However, the attempts to decipher the chemical constituents of anthesins failed. This early disappointment was apparently caused by the macromolecular structure of anthesins which probably comprised some regulatory proteins or even mRNA. This most recent studies in this field produced a sound support to such idea.

The quest for Florigen-

Several genes that control flowering time in *Arabidopsis* have been discovered using recently developed genetic approaches. These genes function in ‘cascades’ within four promotive pathways, the ‘photoperiodic’, ‘autonomous’, ‘vernalization’, and ‘gibberellin’ pathways, which all converge on the ‘integrator’ genes SUPPRESSOR OF OVEREXPRESSION OF CO1 (SOC 1) and FLOWERING LOCUST (FT). Recently, several studies have highlighted a role for a product of FT as a component of the floral stimulus or ‘florigen’. In August

2005, the journal science published at once three papers dealing with the role of the gene FT in formation, translocation, and functioning of the floral stimulus, florigen. FT mRNA as the florigen or atleast one component of the florigen travels from the day length sensor of the plant, namely leaves to the flowering time decision center, namely shoot apex.

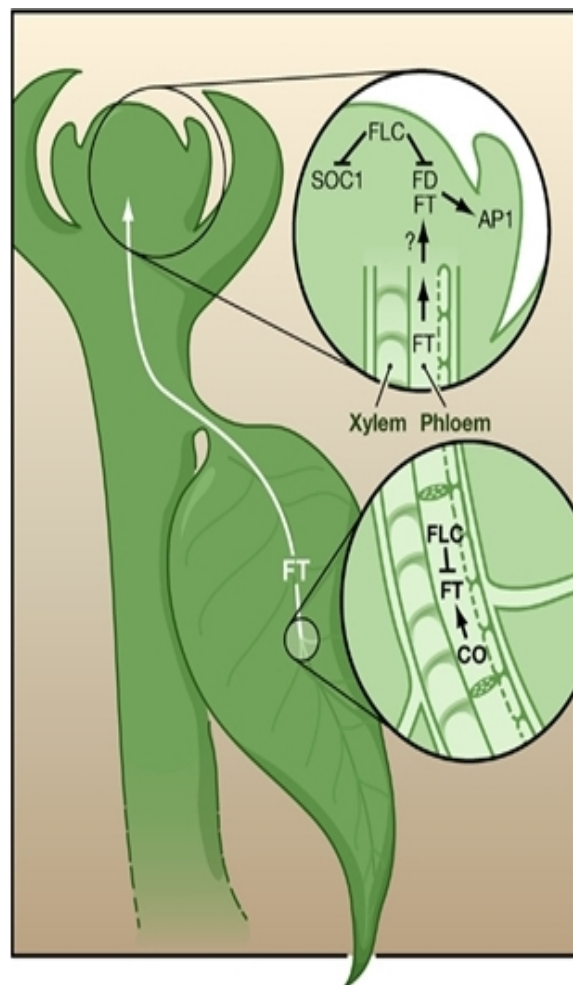

Figure 20 - The photoperiod and FLC Pathways Interact in the Floral Transition. (In favorable photoperiods, CO activates FT in the leaf veins, and this leads to the induction of lowering FT mRNA or FT protein moves in the phloem to the shoot apex, where its interaction partner FD is expressed. At the shoot apex, FT and FD together activate AP1. FLC represses the floral transition by antagonizing FT upregulation in the leaf veins and FD and SOC1 expression at the shoot apex. AP1 and SOC1 induce flowering).

The arrival of this messenger in shoot apex then triggers/induces expression of downstream genes and these ultimately culminate in initiation of floral meristem development. FT has all the hallmarks of florigen. The FT gene is induced in leaves within after plant receive a stimulus that promotes flowering, but its product, the FT protein, acts at the growing tips of the plant to activate the flowering process. The gap between the two sites is bridged through movement of FT mRNA from the leaf to the growing tip. FT, a 20 Kda protein has some sequence similarities to phosphatidylethanolamine binding protein or Raf kinase inhibitor protein.

Existence of Antiflorigen:

Grafting studies have indicated that transferable substance exists in several long-day plants that is produced under-day conditions and suppresses flower formation. It is called antiflorigen. Florigen and antiflorigen appear to be antagonists. The flower formation is mainly based on the ratio of the two substances. Long (1965) suggested that non-induced leaves may produce "antiflorigen" and, that in plants producing both florigen and antiflorigen, floral evocation is caused when the balance of these two factors at the stem apical meristem (SAM) is shifted in favor of florigen.

Floral Repression or Vegetative Action

Theoretically, vegetative development can result either from the activation of a vegetative program or from the repression of the reproductive program. So far, few if any genes that are expressed only in vegetative shoot or that are required only for the growth of the shoot have been found in *Arabidopsis*. Floral repression is likely to be the principal mechanism for maintaining vegetative development, as genes that promote vegetative growth act by repressing genes that are required for flower development. Recent advances in the characterization of some early-flowering genes are beginning to shed light on the mechanisms that repress flowering. Early flowering genes are identified through loss-of-function mutants that flower early. Thus, the wild type alleles of these genes are presumed to function by promoting or maintaining vegetative growth or by delaying reproductive development. Floral repress or genes (mutants of early flowering genes may be classified into two general types: those that function to inhibit the floral signaling pathways and those that might function as epigenetic repressors.

Floral Repressors that inhibit floral signals

Floral repressors inhibit the floral signaling pathways at various levels. Early-flowering genes that are involved in the control of circadian rhythms and light signaling include EARLY FLOWERING 3 (ELF 3) and ELF 4. FLOWERING LOCUS (FLC) encodes a MADS-box protein that represses flowering by inhibiting FT activity. Cold treatment represses FLC, thereby accelerating flowering. FLC repression of FT is maintained by VRN 1 and VRN 2. The impairment of some early-flowering genes causes early flowering.

Floral repressors involved in epigenetic silencing

Several genes exert pleiotropic effects on plant development and flower repression, but, unlike the early-flowering genes, the action of their wild type alleles probably involves chromatin remodeling. Hence, they are termed “epigenetic repressors”.

Plant Circadian Rhythms

The behavior, metabolism and physiology, of most living organisms: from cyanobacteria to human, changes profoundly between day and night. These biological oscillations are apparent as diurnal rhythms to even the most casual observer. Most organisms have the innate ability to measure time and temporally regulate aspects of their biology. Many of these diurnal rhythms persist even in absence of exogenous time cues, indicating their generation by an endogenous biological circadian clock. Photosynthetic organisms derive their energy from sunlight through biochemical processes and for them synchronization to local time is of (obviously) greater significance. It is not surprising that the endogenous nature of circadian rhythms was first established for the leaf movements of the “sensitive” heliotrope (Probably *Mimosa pudica*) by de Mairan, the French astronomer as early as 1729. The mechanisms by which organisms function, in this fourth dimension, time, remains mysterious, curiosity and subject of study for many biologists. The circadian movements of growth and sporulation patterns in fungi (e.g. *Pilobolus* and *Neurospora*), the fragrance emission, hypocotyl expansion the photoperiodic control of flowering time, CO₂ fixation and gene expression are examples of processes tightly regulated by the clockwork of plants. The endogenous oscillator can be considered the clock mechanism, and the physiological functions that are being regulated, such as leaf movement or CO₂ fixation, are sometimes referred to as the hands of the clock.

Circadian rhythms arise from cyclic phenomena that are defined by three parameters namely period, phase and amplitude. Underlying all these physiological rhythms are endogenous circadian oscillations of gene expression. Indeed, genomic approaches have identified in *Arabidopsis* hundreds of genes under clock control, with peaks of expression at all phases of the day/night cycle. Substantial portion of the transcriptome is clock-regulated in fungi, plants and animals. In the most extreme example in the cyanobacterium *Synechococcus elongates* PCC 7042, essentially all gene promoters are under control of the circadian clock and hence transcription rates of the entire genome are circadian regulated. Circadian control of transcription is widespread and the list of plant genes regular by circadian clock is extensive. As determined by microarray experiments about 8000 of the estimated 30,000 genes of *Arabidopsis* may be under clock control. It has been suggested that up to 35% of the transcription may show clock regulation.

The defining characteristic of circadian rhythms, are the subset of biological rhythms with period, defined as the time to complete one cycle of ~24 hours. This characteristic inspired Franz Halberg (1959) to coin the term circadian from Latin words “circa” (about) and “dies” (day).

A rhythm under the control of circadian oscillator must obey three fundamental rules. First, this rhythm must perform in the absence of environmental cues. One of the characteristic attribute of circadian rhythms is that they

are endogenously generated and self-sustaining, so they persist under constant environmental conditions, typically constant light (or dark) and constant temperature under these conditions, the clock oscillates with its free-running period.

The second rule a rhythm must follow to be considered circadian is that it must maintain a fairly constant period length over a range of physiologically relevant temperatures. A characteristic of all circadian rhythms is temperature compensation, the ability of clock to keep time at different temperatures. The temperature compensation of period length assures a relative insensitivity to strong changes in temperature. However, this does not mean that the rhythm will not be affected by temperature cycles from the outside environment. The third most important aspect of a circadian rhythm is entrainment (Synchronization). Under natural conditions, external time cues serve to synchronize an organism, endogenous clock with its environment, a true 24 hours period. The most obvious and important entraining signals are those provided by the alternation of day and night: light-to-dark transition at dusk and dark-to-light transition at dawn.

These environmental cues/periodicities are termed as zeitgebers (German for time givers). The ability of stimulus to reset the clock is a function of the time of day (phase) at which the stimulus is administered. A pulse of light given before dawn will advance the phase of the clock, yet the same pulse of light given after dusk will delay the phase. If given at noon, the same pulse of light will have no effect at all. The biological clock regulates its own sensitivity to environmental stimuli.

Only in exceptional circumstances, such as in the laboratory, is an organism deprived of environmental time cues, such as light/dark cycle or temperature cycles. When the time givers/zeitgebers are removed by transfer to continuous darkness – the rhythm is said to be free-running.

The ability of the environmental signals to effect a stable change of the phase of the organism's internal clock is referred as setting or resetting a circadian in clock. Resetting of a clock is achieved through the modification of the mRNA and/or protein and/or activity levels encoding one or more of the clock components.

McClung (2006) has elegantly described the history of research on circadian rhythms plants. Androstenes described in the 4th century BC, the observation of daily leaf movement of the tamarind (*Tamaricus indicus*) tree, that were observed on the island of Tylos (now Bahrein) during the marches of Alexander the great de Mairan (1729) reported that the daily leaf movements of the sensitive heliotropes plant persisted in constant darkness, demonstrating their endogenous origin. Presciently, de Mairan suggested that these rhythms were related to the sleep rhythms of bedridden humans. These observations were independently repeated after 30 years. Period length of these leaf movements was accurately measured after a century and it was realized that these rhythms were only ~ 24 hours, making the rhythms circadian and suggesting that these rhythms were endogenous. Experiments on the fungus *Neurospora crassa* conducted in space proved that rhythms were truly endogenous.

As early as 1880, Charles and Francis Darwins suggested the heritability of circadian rhythms as opposed to the imprinting of a 24 h period by exposure to diurnal cycle during development.

The presence of an endogenous timing system provides an adaptive advantage, enabling the anticipation of the environmental transitions and the temporal coordination of physiological events to occur at specific phase relationship with the environment. Thus, the circadian clock can be considered as an internal processor of environmental signals (such as light and temperature) that coordinate the appropriate timing of metabolic and developmental activities in the plant.

The circadian system

Classically, the circadian system has been divided into three main components: (I) the input pathways involved in the perception and transmission of environmental signals to synchronize the (ii) central oscillator or pacemaker that generates and maintains rhythmicity through (iii) multiple output pathways that are overt rhythms in gene expression and behavior that connect the oscillator to physiology and metabolism. This though is oversimplified conceptual model of the clock. Several lines of evidence reveal the existence of a far more complicated circadian system, with output elements modulating the pace of the oscillator and input elements being themselves tightly controlled by the clock.

There are multiple photoreceptors that provide input to clock. There must be sensors for temperature and for other environmental stimuli that entrain the clock. In plants, entrainment of the clock to daily cycles of light and dark is controlled by light receptors, including phytochromes (red/far-red light receptors) and cryptochromes (blue light

receptors). In systems like *Drosophila*, *Neurospora* and mammals, the proteins required for the central oscillator form a negative feed back loop based on the control of transcription translation of central clock molecules.

The proteins that form the central oscillator of the plant circadian clock are unknown output pathways in *Arabidopsis* control expression of a wide range of clock-controlled genes that peak in expression in different phase of the cycle, such as COLD AND CIRCADIAN REGULATED 2, GIGANTEA (GI), CHLOROPHYLL A/B BINDING PROTEINZ, and CIRCADIAN CLOCK ASSOCIATED 1 (CCA 1). These pathways also control overt rhythms in leaf movement, stomatal conductance and hypocotyls elongation, and in addition, the photoperiodic control of flowering is also likely to represent an output pathway.

Plant Tropisms: Biological Mechanisms of Movement of Sessile Organisms

Animals can move to more favorable environment, when circumstances become unfavorable for optimum growth and development. Plants are not afforded this luxury. As the plants are sessile, they are forced to adapt according to their immediate surroundings. Plants remain very much in tune with their ever-changing environment. They are capable of a variety of movements. This may come as a surprise to many non-botanists, but not to Charles Darwin, who had a strong interest in plant biology during his multifaceted career. Although it is one of his lesser known works, Charles Darwin, along with Francis Darwin, published a fascinating book in 1880 entitled “The power of movement of plants”. Darwin noted that plants had a tendency to sense their environment so as to orient themselves for optimal growth and development.

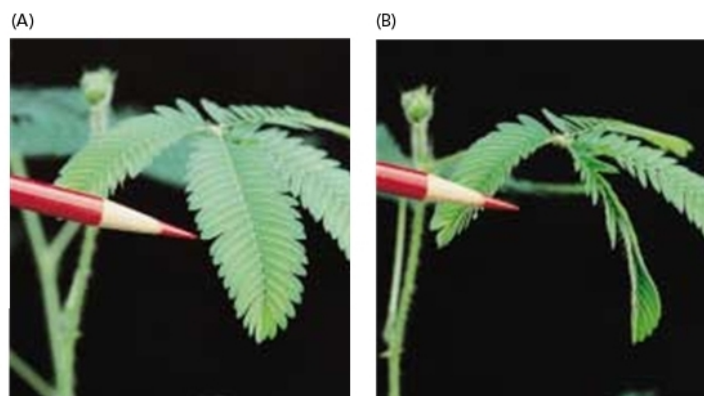

Figure 21- Nyctinastic leaf movements of *Mimosa pudica* (A) leaflets open; (B) Leaflet Closed

Plants constantly experience changes in their environment. Temperature fluctuations, poor light and low water contents in soil are just a few of the factors to which plants must be capable to respond. Moreover, plants must respond to physical forces of nature as gravity or touch stimulation.

The Darwins studied in great detail the two broad categories of plant movements: the tropisms (direct growth in response to external stimuli) and nastic movements. Movements in response to stimuli but the direction are independent relative to the stimulus source). Examples of tropism include gravitropism, directed growth in response to gravity, and phototropism, growth in response to light. Nastic movements include the dramatic leaf movements of venus flytrap after a touch stimulus and the less drastic but more ubiquitous) sleep movements, in which leaves of some plants (Beam plants) move to a different position at night. The Darwins also studied oscillatory movements (also termed circumnutating) in which plants rotate around a central axis during their growth. Almost all plant parts exhibit this movement but some parts show an exaggerated circumnutating.

Over evolutionary time, plants have adapted to their surroundings with high degree of plasticity, affording them the ability to respond ever-changing conditions that provide constant stimulation. Plant tropisms are operationally defined as differential growth responses that reorient plant organs to response to direction of physical stimuli. Tropism can be negative, such as a stem bending away from gravity stimulation, or they can be positive, as in a stem bending towards a light stimulation. Tropisms are different from nastic plant movements, such as the diurnal movement of leaves or the opening and closing of flowers, in that nastic growth is not directional in relation to stimulation. With tropic growth, the direction of the stimulation is very important.

Center of gravity and gravitropism

A plant maintains a proper gravitational set-point angle (GPSA) for a given organ. Each plant organ has a specific GPSA that is wholly dependent upon the age of that organ, type of organ, developmental stage of that organ and the environment in which the plant is growing. When there is deviation from the GPSA, a plant responds to the stimulation accordingly through differential cellular elongation on the side away from the stimulation. This results in tip curvature and ultimately the GPSA is regained. One of the most important mechanisms that plants have acquired is the ability to sense gravity and use it as a basis for governing their growth orientation, a process known as *gravitropism*. Using gravitropism plants can effectively take up water and nutrients from the soil or effectively absorb light energy from the atmosphere by expanding either roots, or leaves, respectively. In addition to gravitropism, gravity affects how plants build their bodies, anchor themselves, and elevate their apical meristems to higher positions. For example, plants synthesize tough cell walls to withstand gravitational forces, and cucurbitaceous plants develop a peg that functions to pull the seed coat out only on the gravi-stimulated side of the region between the root and hypocotyls. Gravi-responses also participate in the regulation of apical dominance. Intense studies of these forms of gravimorphogenesis led to many discoveries of the molecular mechanisms of gravitropism.

The most popular explanation for how plants perceive changes their gravity environment is the starch/statolith hypothesis, whereby starch-filled amyloplasts are displaced when the gravity stimulation changes. Amyloplasts are found in the columella cells of the root cap (*Statoliths*) and in the endodermal cells of the shoot (*Statocyte*). It is suggested that sedimentation of amyloplasts disrupts the plant cytoskeleton by breaking through the dense local networks of actin microfibrils linked to the plasma membrane(s). This physical perturbation is proposed to lead an activation of mechanosensitive ion channels in the membranes. The F-actin cytoskeletons are hypothesized to play a role in signal transduction mechanisms of gravitropism by interacting with sedimenting amyloplasts as they transverse statocytes of gravistimulated plants. A model for gravitropism in stem-like organs is proposed in which F-actin modulates the gravity by actively participating in statolith redepositing within endodermal statocytes. Cytoskeleton acts in regulatory capacity that acts antagonistically to the persistent gravity stimulation by constantly resetting the gravitropic-signaling system. Role of calcium ion (Ca^{2+}) and Inositol-1, 4, 5-triphosphate (IP 3) as second messengers has also been suggested in gravitropically stimuli. Changes in pH due to fluxes in protons (H^+) have also been implicated as a signaling mechanism in gravitropism. Studies on *Arabidopsis* mutants have suggested that gravity related signaling in plants is ultimately coupled to auxin transport, redistribution and response.

Genes of PIN family and AUX 1 appear to function in transport of auxin from the vasculature to the root tips. Mutations in these genes exhibit dramatic defects in response to gravity stimulation. The Sgr (shoot gravitropism) class of mutants exhibit severely impaired (or lack) of gravitropism and represent another set of mutants that have provided significant new insights into the mechanisms of gravitropic signal responses. Role of adenosine kinase (ADK) as a modulator of root cap morphogenesis and gravitropism has been recently described.

Shoot Circumnutating and winding movements

Plant organs display helical growth movements known as circumnutations. These movements help plant organs find suitable environmental cues. The amplitude, period and shape of the circumnutation depend on the plant species, the plant organ involved, and the developmental stage of growth circumnutation interacts with other types of movements such as tropisms. There are suggestions that circumnutational movement involve a gravitropic reaction. There has been no direct evidence yet for the involvement of the graviresponses in circumnutation. The hypocotyls of space-flown sunflower showed circumnutation in microgravity. It has also been demonstrated in rice coleoptile that circumnutation might be independent of gravitropism, but its mechanism might include gravity perception.

Climbing plants grasp a support by various means, for example the stems wind along the support for growing upward in morning glory. Generally, relatively more circumnutation can be observed in the vines and shoots of climbing plants (e.g. morning glory). That needs to be anchored for support than in the shoots of nonclimbing plants. It is therefore thought that circumnutation provides the motive power for the winding response of climbing plants, but there is no direct evidence for the casual relationship between circumnutation and winding response. To gain insight into the mechanisms that explain the relationship among graviresponse, circumnutation, and winding response, Japanese scientists used a gravitropic mutant [Shidare-asagao (weeping)] of Japanese morning glory (*Pharbitis nil*). The weeping shoots display agravitropism whereas the roots are gravitropically normal. It has been reported that the shoots of weeping are defective not only in circumnutation but also in the winding response. These mutants studies on this model mutant plant have revealed that gravisensing endodermal cells are indispensable for shoot circumnutation and winding responses.

Phototropism

Phototropism, or the directional curvature of organs in response to lateral differences in light intensity and/or quality, is one of the most rapid and visually obvious responses of plants changes in their light environment. A number of plant organs respond to phototropic stimuli. Stems, in particular exhibit positive phototropism, while roots exhibit negative phototropism.

Phototropic responses are distinguished from other types of light–modulated directional growth responses, such as nastic and circadian regulated leaf movements by two criteria : (1) the direction of phototropic curvatures is determined by the direction of the light stimulus while direction of nastic/circadian regulated movements, are not, and (ii) many leaf movement responses occur as a result of reversible swelling/shrinking of specialized motor, or pulvinar, cells, whereas all stem and root phototropic responses are driven by changes in cell elongation rates across the binding organ. The differential growth rates, driving the development of phototropic curvatures to be established as a result of differential responsiveness to the plant hormone “auxin” which is Greek for “to increase” – an appropriate name given its properties to promote cell elongation. Cholodny (1927) and Went and Thimann (1939), independently, proposed that it was due to distribution of a growth promoting substance from one side of a plant to the other that lead to the photoperiodic response. Perception of photons of light energy leads to a differential growth response that is potentially based on hormone gradient.

Phototropins, a class of chromoproteins sense blue–light mediate blue–light–induced phototropic responses. While other families of photoreceptors such as the phytochromes and cryptochromes play varying roles in phototropic responses. PHOT 1 AND PHOT 2 are two phototropins in *Arabidopsis*. PHOT 1 was first of the phototropins. Its mutant (Phot 1) showed impaired phototropic response under low fluence blue light. Under high fluence blue light, however, Phot 1 mutant exhibited a normal phototropic response. PHOT 2, the second phototropin was identified through sequence homology to PHOT 1. Phot 2 single mutants retained an essentially wildtype response under all fluence rates tested. Double mutant Photo 1 Phot 2 lack phototropic responses in both low and high fluence rate blue light. Thus Phot 1 and Phot 2 function redundantly as high light receptors, while Phot 1 acts as the low–light photoreceptor. PHOT 1 is 124 KD and PHOT 2 is 110 KD. Phototropin 1 has two LOV (light, oxygen and voltage) domains, LOV 1 and LOV 2, in the N–terminal region and domain homologous to serine–threonine kinase towards the C–terminus. The LOV domain absorb blue light through an associated flavin mononucleotide chromophore while the kinase domain thought to be associated with signal transduction. Phot 1 and Phot 2 are phototropic receptors but these represent only two of molecularly known receptors in *Arabidopsis*. It has been suggested that at least in etiolated seedlings cryptochromes and phytochromes do not function as primary phototropic receptors. Phytochrome family has been proposed to act together with blue–light receptors to mediate phototropic responses in deetiolated (light–grown) seedlings of number of plant species.

Recent finding that an auxin–responsive transcription factor is necessary for proper phototropic curvature (response) gives credence to the long held notion that the phototropic response is based on an auxin gradient. This further suggests that changes in gene expression are necessary component of the phototropic response system.

Thigmotropism

Thigmotropism is the response of a plant organ to a mechanical stimulation. One can imagine that the gravitropic and thigmotropic response of root might be intimately related. In fact, a recent study suggests that proper root tip growth requires the integration of both a gravity response and a touch response. A group of five genes termed the TOUCH (TCH) family, are responsible for mechanosensory responses in *Arabidopsis*. TCH 1 encodes a calmodulin (CaM) while TCH 2 and TCH 3 encode calmodulin–like genes.

Hydrotropism

Hydrotropism can be defined as growth or movement in a sessile organism towards or away from water. Preference of roots for soil with a higher water potential is the best example of hydrotropism. Plant roots penetrate the soil in search of highest potential. However, there is little knowledge about the mechanism through which this actually happens. We know that gravity is the driving force behind a root’s downward growth. This growth is modulated by mechanostimulation of soil particles. The search for highest water potential is likely to play some role in the integrated growth response. The difficulty in studying hydrotropic growth comes in separation of this response from other tropic responses, gravitropism chiefly among them and drought responses that can occur if plants are water stressed. This is further complicated due to the fact that the root cap is proposed as signal integration center for both the gravitropic and hydrotropic responses. Most studies of hydrotropism have been done using on either pea mutants, ABA, auxin or agravitropic mutants of *Arabidopsis* or maize roots. Calcium is important for a hydrotropic response as is auxin and potentially other plant hormone responses. Recently two

mutants have been identified in *Arabidopsis* which do not show a hydrotropic response. No hydrotropic response 1 (nhr1) and root *hydrotropis* (rhy) are mutants which exhibit no hydrotropism.

Vernalization

As the plants are sessile organisms, they have to readily alter their development and growth responses to survive an ever-changing environment. In all facets of development, from germination to flowering, plants use correct amalgamation of multiple external signals including light and temperature. Temperature as an environmental factor profoundly influences developmental programs of plants. Temperature plays a major role in controlling the degree of seed dormancy/seed germination and vegetative growth. In some plant species, long cool winter periods, are required to enable flowering. This inductive process, called vernalization, is a strategy that ensures flowering only occurs in the more desirable spring or summer climate. This vernalization is the process by which flowering is induced/promoted by a cold treatment given to a hydrated seed or to growing plant. Day seeds do not respond to the cold treatment. Without the cold treatment, plants that require vernalization show delayed flowering or remain vegetative. Over the 20th century, vernalization has been studied extensively at the physiological level. Gassner (1918) reported that a wide range of plant species require cold treatment/exposure to flower. In fact, the term vernalization comes from studies of flowering in cereals. The infamous Russian geneticist Trofim Lysenko, who studied the effect of cold on flowering, coined the term jarovization to describe what we now vernalization. Spring cereals are called jarovoe in Russian (derived from Jar, the god of spring) and cold exposure causes a winter cereal to behave like a jarovoe (i.e. flower rapidly). Jarovization was translated from Russian into vernalization; vernal is derived from Latin word for spring, vernum.

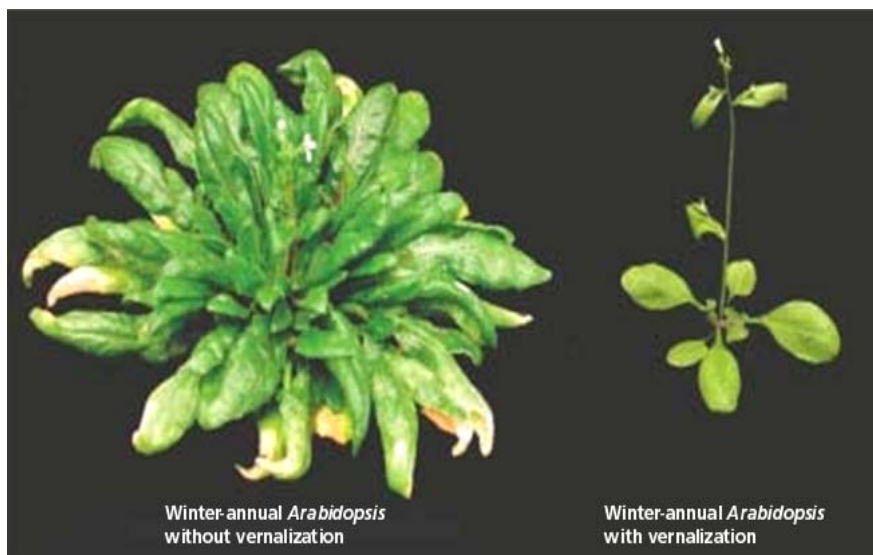

Figure 22-Vernalization induces flowering in the winter-annual types of *Arabidopsis thaliana*. The plant on the left is a winter –annual type that has not been exposed to cold. The plant on the right is a genetically identical winter- annual type that was exposed to 40 days of temperature slightly above freezing (4°C) as a seedling .it flowered 3 weeks after the end of the cold treatment with about 9 leaves on the primary stem.

A useful definition of vernalization is “the acquisition or acceleration of the ability to flower by a chilling treatment”. As noted in this definition, cold exposure does not necessarily cause flowering but rather renders the plant competent to so. Vernalization should be followed by inductive photoperiod to flower. If vernalized plants are grown non-inductive photoperiods, they continue to grow vegetative. However, if such plants are later shifted to inductive photoperiods, they still flower. This shows that the vernalized plant remember their prior vernalization; that is, they had acquired competence to flower but did not actually do so until the photoperiod requirement was met. Thus a cellular memory is established by exposure to cold treatment that is stable through mitosis, but, importantly not through meiosis. The length of this memory winter varies among plant species.

Two types of experiments demonstrate that this acquisition or acceleration of flowering after chilling treatment occurs at the shoot apex. One is to locally chill only certain parts of the plant. Another is to graft short tips: In most species, if vernalized shoot tip as grafted to non-vernalized stock, it will flower, but a non vernalized shoot tip grafted to vernalized stock will not flower.

The effective temperature range for vernalization is just below freezing to about 10°C, with broad optimum usually between about 1 and 7°C. The effect of cold increases with duration (4 to 12 weeks) of the cold treatment until the response is saturated. Vernalization is a quantitative response with increasing periods of low temperature causing progressively the earlier flowering until a saturation point is reached.

Vernalization can be lost as a result of exposure to devernaling, conditions, such as high temperature, but the longer the exposure to low temperature, the more permanent the vernalization effect.

Vernalization is an epigenetic switch

Vernalization is effective, if active metabolism occurs during the cold treatment. Sources of energy and oxygen are required, and temperature below freezing at which metabolic activity is suppressed is not effective for vernalization. It has been suggested that the vernalization induced, mitotically stable acquisition of the competence to flower, be referred as an epigenetic switch because it is a change that can be propagated through cell division in the absence of the inducing signal. However, there may be disagreement over the use of the term epigenetics. Some might argue that the term epigenetics should be used only for changes that persist from one generation to the next. This is course does not happen in the case of vernalization.

Nevertheless, many studies have shown that the vernalization state can be stable; i.e. after exposure to cold has ended, competence to flower, in certain species, can persist for many months and throughout many cell divisions in the shoot apical meristem. Thus, plants can exhibit a 'memory of winter' and vernalization can result in an epigenetic switch in the classic sense of the term: a change that is stable in the absence of the inducing signal.

Genetics and Molecular Mechanisms of Vernalization:

In naturally occurring *Arabidopsis* accessions, FRIGIDA (FRI) and FLOWERING LOCUS C (FLC) determine the requirements for vernalization. FRI encodes a novel protein that increases the mRNA level of the MADS-domain gene FLC. FLC acts as a strong floral repressor by negatively regulating the expression of genes that promote the floral transition including SOC 1/AGL 20 and FT. Vernalization promotes flowering by reducing FLC mRNA levels by antagonizing FRI function. The extent of this reduction is proportional to the duration of vernalization and is closely correlated with flowering time. FLC expression is also down regulated by the action of genes of autonomous floral promotion pathway i.e. FCA, LUMINIDEPENDENS (LD), FVE and EPA. Mutations in these genes cause increased FLC levels and a late-flowering phenotype that can be reversed by vernalization. Several VERNALIZATION (VRN) genes have been identified which mediate the vernalization responses in *Arabidopsis*. VERNALIZATION 1 (VRN 1) is plant-specific DNA binding protein. VRN 2 is a relative of polycomb-group protein. VERNALIZATION INSENSITIVE 3 (VIN 3) contains PHD domain. In animals and yeast, proteins related to VRN 2 and VIN 3 are involved in chromatin remodeling complexes. Such complexes often cause modification of histone(s). The spectrum of histone modifications and their effect on gene expression are referred as the histone code. Vernalization brings changes in FLC chromatin. During and after vernalization, the levels of certain modifications associated with active genes are reduced, such as acetylation of histone 3 (H 3) at Lys 9 and 14. By contrast, the levels of two other modifications, methylation of H3K9 and H3K27 are increased by vernalization. Elevated H3K9 and H3K27 methylation is typically associated with the formation of stable heterochromatin. Thus, the vernalization-mediated formation of heterochromatin at FLC appears to account, at least in part, for the epigenetic nature of the vernalization state. Histone deacetylation is one modification of FLC chromatin that occurs during vernalization.

SEED: Development and Maturation

Plants, as sessile life forms have evolved diverse mechanisms to circumvent unfavorable growth conditions, among them interruption of life cycle is one of the most successful strategies. Spermatophyta, or seed plants, are characterized by the formation of the seed, a structure originated from the fertilized ovule that includes the embryo and other maternally derived tissues. Embryogenesis within the seed allows the entry into a quiescent state that represents an evolutionary advantage as it facilitates dispersal and resuming of growth under optimal environmental conditions. Seed formation is an intricate process that can be divided into proper embryogenesis (cell division and morphogenesis), followed by maturation phase characterized by storage compound accumulation, acquisition of desiccation tolerance, growth arrest and the entry into a dormancy period of variable length that is broken upon germination. A seed is a marvelous adaptation for survival of the embryo for long period, often under adverse environmental conditions. Such survival allows opportunities for dispersal, both in time and space. During this period, attacks by bacteria, and fungi is prevented as the seed is desiccated and covered by hard seed coat. Also seeds of many species contain phenolics, lectins, toxic glycosides, and enzyme inhibitors to discourage predation by insects, rodents and herbivores. Seeds are vital components of the world's diet.

A seed usually comes with everything it needs for germination and early seedling growth, including reserve food and minerals, and at that time requires only the right temperature, water (H₂O) and oxygen from the environment. Besides the basic requirements, the seed may also be sensitive to other factors such as light and/or nitrate. Moreover in many cases, the seed, more properly the embryo, exercises its own control on germination.

Definition of seed germination

Seed germination is defined as the sum of events that commence with the uptake of water by the quiescent dry seed and terminates with/culminates in elongation emergence of embryonic axis (usually the radicle) from the seed coat. The uptake of water by seed is triphasic with a rapid initial uptake (phase I, i.e. imbibition), followed by a plateau phase (phase II). A further increase in water uptake (phase III) occurs as the embryo axis elongates and breaks through the covering layers to complete germination. In angiospermic seeds the embryo is surrounded by two covering layers: the endosperm and testa (Seed Coat). Cell elongation is necessary and is generally accepted

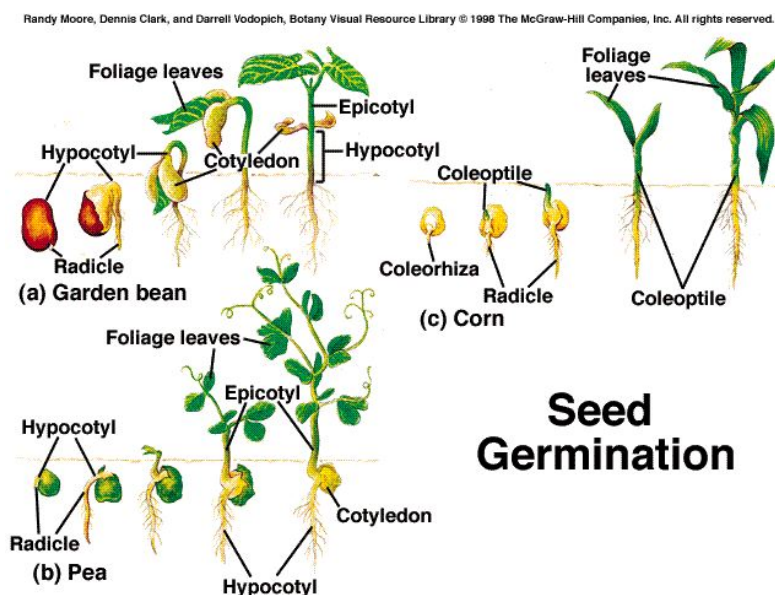

Seed Germination

to be sufficient for the completion of radicle protrusion (visible germination). Because dormant seeds do not complete germination, they can not enter phase III. Germination occurs over a wide range of temperature. For each species there is an optimal requirement. Almost all seeds are capable of some anaerobic respiration in the early hours of imbibition. Seeds of some plant grow in flooded soils with low oxygen tension (e.g., Rice, barnyard grass, and *Typha latifolia*) are capable of germination under anaerobic conditions. These seeds exhibit activities of alcohol dehydrogenase (ADH) and lactate dehydrogenase (LDH) enzymes

involved in the fermentation of pyruvate produced during glycolysis to ethanol or lactate respectively. The quiescent dry seed rapidly resumes metabolic activity. One of the first changes upon imbibition is the resumption of respiratory activity, which can be detected within minutes. After a steep initial increase in oxygen consumption, the rate declines until the radicle penetrates the surrounding structures. At this stage another rise of respiratory activity occurs. The glycolytic and oxidative pentose phosphate pathways both resume during phase I, and the Krebs's cycle enzymes become active. During germination of embryo, pre-existing mitochondria are repaired and re-activated and/or biogenesis of mitochondria occurs.

All of the components necessary for the resumption of protein synthesis upon imbibition are present within the cells of mature dry embryos, although polysomes are absent. Within minutes of rehydration there is a decline in single ribosomes as they become recruited into polysomal protein-synthesizing complexes. Initial protein synthesis is dependent on extant ribosomes, but newly synthesized ribosomes are produced and used within hours of initial polysome assembly.

New mRNAs are transcribed as germination proceeds. The majority of these are likely to encode proteins essential for normal cellular metabolism (growth maintenance) that are not restricted to germination. No specific protein markers exclusively to germination have been found.

Elongation of radicle and its emergence from the seed coat complete phase II of imbibition and germination. The rupture of the seed coat in most cases occurs with pressure from the growing radicle tip. Probably hydrolysis of wall polysaccharides of the surrounding occurs. Synthesis of cell wall hydrolyzing enzymes has been reported in tomato and *Datura*. Typically, cell division is not necessary for radicle emergence but for subsequent growth, it is necessary.

Inhibition of Seed Germination

The presence of free ABA in seeds of after uptake from the ambient medium inhibits seed germination. Seeds of ABA-deficient mutants germinate readily in water, but fail to do so if supplied with ABA. ABA insensitive mutants also germinate readily or require much higher concentrations of ABA to inhibit germination than the wild type. Other inhibitors of seed germination, besides ABA, are phenolic compounds namely trans-cinnamic acid, coumaric acid, and comarin, which are usually inhibitory at concentrations of 10^{-4} M or above.

Modulation of Seed Germination

It has been suggested that seed germination is regulated by a balance between the relative amounts of endogenous GA and ABA in the seeds and sensitivities of seed tissues to these hormones. It has been well documented that GA promotes seed germination in many plant species. In *Arabidopsis thaliana*, severe GA deficient-mutants, such as *ga 1-3* and *ga 2-1*, are defective in seed germination. In addition, chemical inhibitors of GA biosynthesis enzymes, such as uniconazole and paclobutrazol inhibit seed germination. These observations suggest that de novo GA biosynthesis is necessary for seed germination after inhibition in *A. thaliana*. In fact, the level of bioactive Gas has been shown to increase just before radical protrusion in germinating seeds. In rice, mutant analysis has implicated G Protein signaling in GA-stimulated expression of several genes including transcription of the gene encoding enzyme α -amylase which breaks down carbohydrates that nourish the young seedlings.

Light is a critical environmental determinant for seed germination. The effect of light on seed germination is primarily mediated by the Red (R) and far-red (FR) light photoreceptors – the phytochromes. In fact control of seed germination by red and far-red light is one of the earliest documented phytochrome-mediated processes. The best-characterized phytochrome control of seed germination is called the low-fluence response (LFR), in which R light promotes and FR light reversibly inhibits germination. There are evidence that GA biosynthesis is regulated by phytochromes in germinating seeds, in which genes encoding GA 3-oxidase are regulated by R and FR light in a photo reversible manner.

Temperature is another crucial external cue that control seed germination. In many plant species, exposure of seeds to low temperatures (typically 2 to 5°C) immediately after imbibition promotes germination. Such cold treatments are often called stratification. It has been illustrated that GA biosynthesis and response pathways are activated during seed imbibition at low temperature.

Seed Dormancy and its regulation

Seed dormancy is an innate property of plant seed that defines the environmental conditions, in which the seed is able to germinate. Seed dormancy is determined by genetics with a substantial environmental influence which is mediated, at least in part, by the plant hormones abscisic acid (ABA) and gibberellins. The status of dormancy is influenced by the environmental factors that exist at the time of seed maturation. Even after shedding of seed, the status of dormancy is determined by the ambient environment. As dormancy exists throughout the higher plants in all major climatic regions, several adaptations have occurred in diverse responses to the environment. Through this adaptation, germination is timed to avoid unfavorable weather for subsequent plant establishment and reproductive growth.

A completely nondormant seed has the capacity to germinate over the widest range of normal physical environmental factors possible for the genotype. Besides the basic requirement for water, oxygen, and an appropriate temperature, the seed may also be sensitive to other factors such as light and/or nitrate. Germination commences with the uptake of water by imbibition by the dry seed, followed by embryo expansion. The uptake of water is triphasic with a rapid initial uptake (phase I, i.e. imbibition) followed by a plateau phase (Phase II). A further increase in water uptake (Phase III) occurs as the embryo axis elongates and breaks through the covering layers to complete germination. Cell elongation is necessary for the completion of radicle protrusion/emergence (by overcoming the mechanical constraints imposed by the endosperm and seed coat/testa – the two covering layers that surround the embryo in typical angiosperm seed). A simple operational definition of seed dormancy is that Seed dormancy is a block to the completion of germination of an intact viable seed under favorable conditions. This however, is one of the least understood phenomena in the field of seed biology. Definitions of dormancy are difficult because dormancy can only be measured by the absence of germination. We can observe completion of germination of a single seed as an all-or-nothing event, whereas dormancy of a single seed can have any value between all (maximum dormancy) and nothing (nondormancy). Dormancy should not just be associated with the absence of germination(s) rather; it is a characteristic of the seed that determines the conditions required for germination.

The block to germination has evolved differently across species through adaptation to the prevailing environmental conditions, so that germination occurs when conditions of establishing a new plant generation are likely to be suitable. Therefore diverse range of blocks (dormancy mechanisms) has evolved, in which they operate.

Secondary dormancy can be induced by abscisic acid (ABA) and other terpenes which may be present in leachate from litter that covers the seeds in their habitat. Freshly harvested mature water-permeable dormant seeds are said to have primary dormancy, which has been induced with the involvement of ABA during seed maturation on the mother plant.

Dormancy is determined by both morphological and physiological properties of the seed. Five classes of seed dormancy are physiological (PD), morphological (MD), morphophysiological (MPD), physical (PY) and combinational (PY + PD).

1. **Physiological dormancy (PD):** PD is the most abundant form. It is found in seeds of gymnosperms and all major clades of angiosperms. This is major form of dormancy in model species used in the laboratory. PD can be divided into three levels: deep, intermediate and non-deep.

Embryos excised from seeds with PD deep, either do not grow or will produce abnormal seedlings. GA treatment does not break their dormancy and several months of cold (subtype a) or warm (subtype b) stratification are required before germination can take place. Examples: *Acer platanoides* (PD deep) and *Acer pseudoplatanus* (PD intermediate).

The great majority of seeds have non-deep PD. Embryos excised from these seeds produce normal seedlings. GA treatment can break this dormancy.

2. **Morphological dormancy (MD):** MD is evident in seeds with embryos that are underdeveloped (in terms of size), but differentiated (e.g. into cotyledons and hypocotyl-radicle). These embryos are not (physiologically) dormant, but simply need time to grow and germinate. Example: Celery (*Apium graveolens*).
3. **Morphophysiological dormancy (MPD):** MPD is also evident in seeds with underdeveloped embryos, but in addition they have physiological components to their dormancy. These seeds therefore require a dormancy-breaking treatment, e.g. a defined combination of warm and cold water stratification which in some cases can be replaced by GA application. There are eight known levels of MPD. Examples: *Fraxinus excelsior*, *Trollius*.
4. **Physical dormancy (PY):** PY is caused by water-impermeable layers of palisade cells in the seed or fruit that control water movement. Mechanical and chemical scarification can break PY dormancy. Examples: *Melilotus* and *Trigonella* (Methi).
5. **Combinational dormancy (PY + PD):** PY + PD is evident in seeds with water-permeable coats (as PY) combined with physiological embryo dormancy (PD). Examples: *Geranium* and *Trifolium*.

Regulation of seed dormancy

Physiological and molecular biological work has provided insight into mechanisms of non-deep physiological dormancy. Embryo dormancy and coat dormancy are components of PD; their sum and interaction determine the degree of ‘whole seed’ PD. At molecular level, very little is known about MD, MPD, PY, PY + PD and deep PD. Embryo dormancy is characterized by a block that inhibits extension growth, and therefore excised embryo do not grow. Coat dormancy is characterized by a block that is conferred by the covering layers. ‘Coat’ is used in a loose sense and can be any embryo-covering structure, for example testa, endosperm and/or pericarp.

ABA is an important positive regulator of both the induction of dormancy and the maintenance of the dormant state in imbibed seeds following shedding. ABA deficiency during seed development is associated with absence of primary dormancy in the mature seed. Over expression of ABA biosynthesis genes can increase seed ABA content and enhance seed dormancy or delay seed germination. A lasting dormancy is imposed by ABA produced by seed itself during its development. ABA application during seed development does not induce lasting seed dormancy. ABA biosynthesis in the embryos and that in the endosperm both contribute to the induction of seed dormancy. Seed dormancy in strongly dormant *A. thaliana* ecotype *cvi* exhibited that dormancy depend on an intrinsic balance of GA and ABA biosynthesis and catabolism. The net result of the dormant state is characterized by increased ABA biosynthesis and GA degradation. ABA induces dormancy during maturation, and GA plays key role in release of dormancy and hence in the promotion of seed germination. It has been shown that the dormant state of embryo has transcription of genes with an overrepresentation of ABA-responsive elements (ABRE) in their promoters and of genes for transcription factors that bind to the ABRE. The ABRE-binding transcription factors appear to be master regulators that mediate ABA responses in seeds, including the regulation of dormancy.

Applied aspects of the control of germination by seed dormancy

Seeds are the delivery systems for agricultural biotechnology, and high levels of “field” performance (seed quality) are essential for predictable seedling establishment. High seed quality and seedling establishment can be considered as cornerstones of profitable, efficient and sustainable crop production. Dormancy (usually low) is an important component of physiological seed quality and so plants with a long history of domestication and plant breeding generally have a lower seed dormancy than wild or more recently domesticated species. However, dormancy can increase when germination takes place under stress (i.e. poor field conditions). In practice, dormancy not only affects the number of seeds which germinate (high dormancy), but also their rate of germination (low dormancy) especially under sub-optimal conditions. A rapid germination rate is a widely accepted measure of seed vigor; a key component of seed quality that is little understood. In cereal crops, a certain degree of dormancy at harvest is a desirable trait because it prevents viviparous germination of grains in the head. This pre-harvest sprouting may cause reduced grain quality at harvest and therefore serious economic losses. In contrast, high harvest dormancy of barley results in extra storage costs because the grain requires after-ripening to achieve the rapid and uniform germination required for the malting process. Thus, a defined level of seed dormancy is an essential component of seed quality. The horticultural and forestry industries also have a requirement for predictable seedling establishment, but many of the species used still wild characteristics, and so dormancy can be particularly problematic. Practical methods to release dormancy and induce germination include after-ripening, temperature treatment, hormone application (GA), scarification, and various technologies for seed enhancement like priming. However, while seed enhancements like priming may overcome dormancy to improve the percentage and uniformity of germination they can decrease seed storability and longevity.

Weed control is an integral part of efficient crop production that has benefited from developing new methods of dormancy release and from the increasing understanding of allelopathic interactions. Nevertheless a lack of knowledge concerning the annual dormancy cycle of buried weed seeds and an inability to predict their germination time limits the introduction, accurate targeting and success of many novel weed control methods and in particular those for low-input (non-chemical; sustainable) agricultural production. Increasing knowledge of the molecular mechanisms of dormancy will reveal further ways to improve seed technologies and seed quality.

Physiology of senescence

It is not very clear when the word senescence was introduced in science. Nonetheless, the term senescence was apparently used in everyday Latin. In animal sciences the term was used as least as early as 1879 and with reference to plants not later than 1915. Its use may have been begun considerably earlier. The Latin verb *senescere* means to grow old. About a century ago, the word ‘senescence’ was conceived of, in scientific texts, as the end phase of differentiation, the phase that ends in death.

Death is the inevitable end of the process of senescence (CM Child 1915 in senescence and rejuvenescence). Leopold (1961) defined senescence in plant cells as “the deteriorating process that is natural cause of death. Later on Leopold explained ‘senescence refers to those changes that provide for the endogenous regulation of death. Physiological changes involved in the autumnal coloring (and subsequent death) of leaves or in the dieback of tulips in early summer or in the yellowing and death of annual and biennial species after the completion of fruiting would be examples of senescence. This definition emphasizes the underlying process that causes the death. Although this is now mostly forgotten process of senescence and cell death has already been noted by the early microscopists, whose observations were often strikingly correct. Lange (1891) reported that a decrease in cytoplasm, and a drastic decrease in the number of organelles preceded cell death during xylem vessel formation. Prior to death, it was suggested, macromolecules such as proteins were degraded to small soluble compounds that were taken up by neighboring cells. He insisted that the death of the xylem cells was determined their developmental context (programmed?). Thus the concept of a programmed death has thus existed for a long time, before the term programmed cell death (PCD) was coined during the 1960s.

Plant scientists, applied the term senescence mainly to the death of individuals, and that of organs, but also in conjunction with death in tissues (e.g. endosperm senescence) or individual cells. Senescence is distinct from necrosis, though both of these lead to death. Necrosis is death brought about by physical damage, poisons/toxins, or other external injuries. Senescence is a natural/normal, energy dependent developmental process regulated by the genetic program of plant itself. Leaves are genetically programmed to die and their senescence can be initiated by environmental cues. Senescence of plant organs is associated with abscission, a process by which specific cells in the petiole differentiate to form an abscission layer. This causes separation of the senescent organ or ripe fruit from the mother plant.

There are types of senescence, each with its own genetic program. The causes of senescence may be internal or external such as day length and temperature. However, the different senescence patterns may share common internal programs. Probably early senescence related genes and initiate a cascade of subsequent gene expression leading to senescence and death.

Plants exhibit various types of senescence. Many annual plants like wheat, maize, soybean. Rice and Millets, at once die following flowering and fruit/seed production, even under optimal growing conditions. Senescence, after a single reproductive cycle, of the entire plant, is called monocarpic senescence. Senescence of aerial shoots (in herbaceous perennials); seasonal leaf senescence (in deciduous trees); sequential leaf senescence in which leaves die after certain, age, senescence (ripening) of fruits senescence of cotyledons and floral organs and senescence of specialized cell types (trichome, tracheids, and vessel) elements are commonly observed events. In fact senescence exists wherever there is plant life. Many environmental stresses and biologic insults such as extreme temperature(s), drought, nutrient deficiency, insufficient light/shadow/darkness, and pathogen infection can cause senescence. Internal factors like age, levels of plant growth regulators and reproductive growth may also control senescence.

Some authors have used the two terms senescence and programmed cell death (PCD) interchangeably. Programmed cell death in floral organs is very common. Floral death after pollination is to remove it from population for various ecological reasons. One of the key trigger for petal death and removal is pollination which initiates a series of physiological events orchestrated by plant growth regulators. Ethylene is clear regulator of petal senescence in some species. In Petunia, tobacco, carnation and even orchids, senescence is mediated by the evolution of ethylene following contact between pollen and the stigma surface, which precedes fertilization. Van Doorn and Woltering have recently categorized plant PCD into three types: apoptotic, autophagic and neither apoptotic nor autophagic. In the tapetum and pollen-tubes, there is evidence to support import role for the mitochondria and involvement of caspases.

Senescence is characterized by a transition from anabolic to catabolic processes. The chloroplast is the first organelle to show drastic change due to differential breakdown of its components. Consequently, a decline in photosynthetic activity occurs that trigger the induction of senescence syndrome. This metabolic turning point is also associated with the transitions from nutrient assimilation to nutrient remobilization (recycling). Senescence-associated vacuoles (SAVs) with intense proteolytic activity develop in the peripheral cytoplasm of leaf cells. During senescence, the hydrolytic enzymes degrade many cellular macro (molecules) including carbohydrates, lipids, nucleic acids and proteins. The released nutrients are mobilized for re-use in other parts of the plants.

Intense catabolic activities occur in the senescing tissues. The associated catabolic processes require de novo synthesis of various hydrolytic enzymes like proteases, nucleases, lipases, and chlorophyll degrading enzymes. The synthesis of these, senescence-specific enzymes involves the activation of specific genes. Not surprisingly, the

levels of most mRNAs decline during senescence phase, but the abundance of certain specific mRNA transcripts increases. Expression of *Oryza sativa* delay of the onset of senescence (OsDOS), involved in delaying leaf senescence in rice, has been isolated. It is negative regulator for leaf senescence. The knock down of OsDOS by RNA_i caused accelerated age-dependent leaf senescence, whereas its over-expression markedly delayed leaf senescence. Certain genes decrease during senescence. These genes are called senescence down-regulated (SDGs). These SDGs include genes that encode proteins involved in photosynthesis. Senescence, however, is much more than the simple switching-off of photosynthesis genes.

Several genes are induced during senescence. These are called senescence-associated genes (SAGs). SAGs include genes that encode for proteins involved in hydrolytic activities, and ethylene biosynthesis. Other SAGs encode proteins responsible for conversion and remobilization of breakdown products and detoxification of oxidative metabolites. SAGs initiate, regulate and participate in execution phase of the senescence syndrome. Gene expression analysis in senescing leaves have shown that Salicylic Acid (SA), Jasmonic Acid (JA) and ethylene are involved in senescence.

A mutant gene 'stay-green' confers disrupted leaf senescence phenotype in *Lolium multiflorum*. Delay of senescence and abscission by suppression of LX Ribonuclease has been reported. Recently a novel nuclear localized CCH-type zinc finger protein.

Fruit Ripening

Reproduction in flowering plants begins with the formation of the flower and ends with the formation fruit and seeds. Fruit development and seed set in flowering plants normally occur in coordinated manner following pollination of the stigma and subsequent double fertilization in the ovule, a female gamete forming structure, located with the carpel. When the egg and central cell of the female gametophyte are not fused with sperm cells, they remain in quiescent state and eventually degrade as the flower undergoes senescence. This has led to the interpretation that signaling processes are required to activate development of the fertilization products leading to the initiation of seed and fruit development.

Fruit development can be uncoupled from fertilization in plants that undergo the genetically controlled process of parthenocarp and apomixes. Apomictic species can produce both fruit and viable seed in absence of fertilization. Parthenocarp has a genetic basis and has been exploited by farmers and plant breeders for the production of seedless fruits.

Most fruits develop from a gynoecium's that contains one or more carpels. In pseudocarpic fruit, organs other than the gynoecium (e.g. receptacle bract, the floral tube, or the enlarged axis of the inflorescence) participate in the formation of fruit.

When an ovary develops into a fruit, the ovary wall becomes the pericarp.

Fruit, protects seed development and server the vehicle for seed dispersal. Fruits also provide human with a source of nutrition, culinary diversity, and often great pleasure. Fruits from domesticated species often have been tremendously enlarged over that normally found in the progenitor wild species.

Initially, fruit enlarge through cell division and than by increasing volume. The embryo matures and the seed accumulates storage products, acquires desiccation tolerance, and less water. The fruit then ripens Ripening is accompanied by changes in aroma, color, flavor, nutritional contents, and susceptibility to opportunistic pathogens. Ripening can be generally defined as the summation of changes in tissue metabolism rendering the fruit organ attractive for consumption by organisms that assist in seed release and dispersal. The ripening renders, the fruit attractive (appealing) to organisms receiving sustenance in exchange for assisting in seed dispersal. Ripening physiology has been classically defined as, either 'climacteric' or 'non-climacteric'. Climacteric fruits show sudden increase in respiration at the onset of ripening, usually in concert with increased production of ethylene. Ethylene is typically necessary for climacteric ripening. Non-climacteric fruits do not increase respiration at ripening and often have no requirement for ethylene to complete maturation.

Fruit growth, in most species, can be represented by sigmoidal curve. Physiologically and biochemically, fruit development can be divided into four phases, which although occur in continuity, are separated on the basis of the major activities. Phase I includes ovary development in the flower, and (following anthesis) a decision to abort or proceed with further development. Phase II involves a period of rapid cell divisions. Phase III is the period

of most rapid growth, when cell divisions (more or less) ceases and growth is almost exclusively by cell enlargement. During this phase, food reserves are accumulated and most fruits attain their final shape and size before the onset of ripening Phase IV. In some plant species another burst of growth occurs during the ripening period (and hence fruit of such types exhibit double sigmoid growth curve). In some fruits, such as avocado, cell divisions continue well into Phase III. There is much variation among flowering plants in the manner in which fruit arise. Fruit may arise from single or multiple fused ovaries of a single flower (simple fruits), from several single ovaries of a single flower (aggregate fruits), or from ovaries of several flowers in inflorescence multiple fruits.

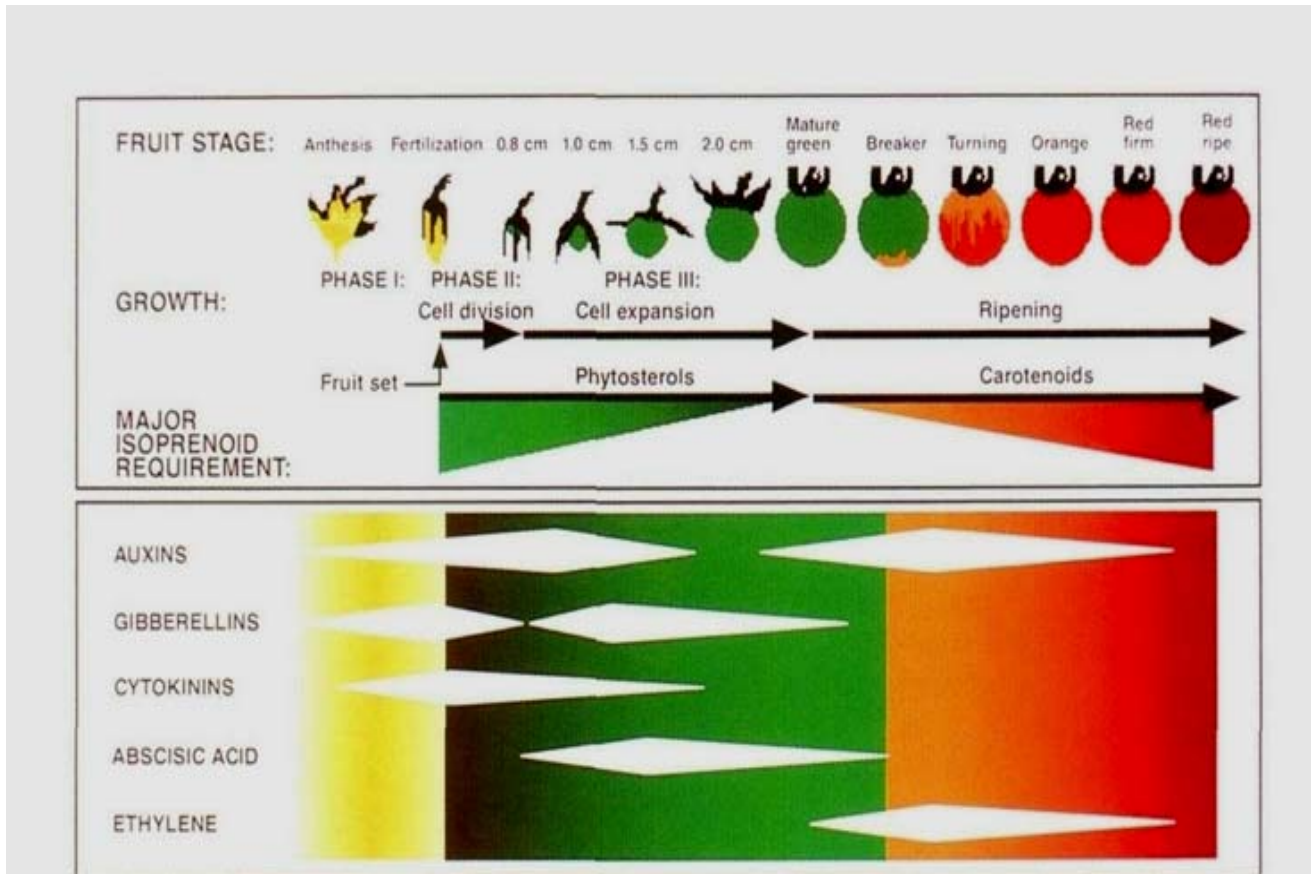

Figure:- 23 (A) stages of fruit development and ripening in tomato.

Mature fruits can be generally characterized as either fleshy or dry. Fleshy fruits typically undergo ripening as

defined above and dry fruits (cereals and legumes) mature in a process more akin to senescence and disperse their seeds via abscission like programs, including dehiscence or shattering.

Fruit ripening is a unique aspect of plant development with direct implication for large components of food supply and related areas of human health and nutrition. The ripening of fruit organs represent the terminal stage of development in which the matured seeds are released. Although the specific biochemical and physiological programs resulting in ripening phenomena vary among species, typical changes include (a) alteration in chlorophyll and carotenoid contents and accumulation of flavonoids resulting in modification of color, (b) alteration of cell turgor and cell wall structure and/or metabolism and change in texture, (c) modification of starch sugars, acids, and volatile profiles that affect nutritional quality, flavor, aroma and taste. From a practical viewpoint, a number of ripening characteristics result in negative quality attributes including decrease self-life and high input harvest, shipping/transport and storage practices. The ripening associated changes in firmness and overall decrease in resistance to microbial infection brought about by the ripening process and associated tissue deterioration are particularly important. Ripening has an impact on fiber content and composition, lipid metabolism, and levels of vitamins and various antioxidants. It is important to understand the process of fruit

ripening as this will increase the ability to understand and manipulate, through breeding or biotechnology, key control points in the global control of ripening or specific stages/regulatory points of specific ripening process.

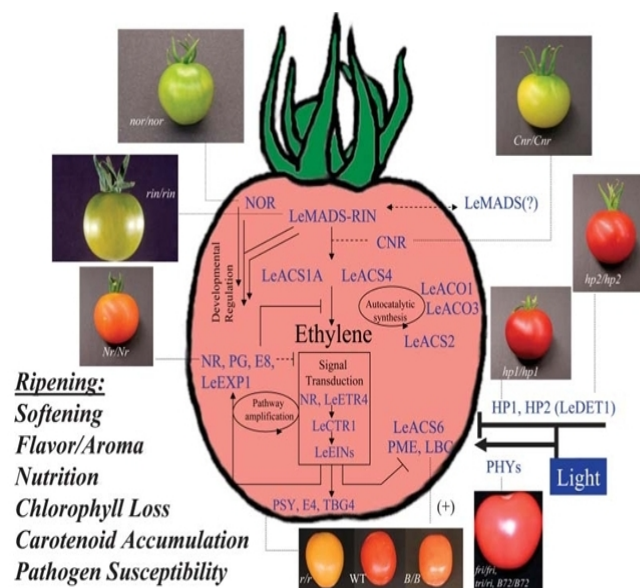

Figure 23 (B)-Model for the Molecular Recognition of Fruit Ripening In Tomato

Fruit species are classically defined as one of two ripening types, climacteric and non-climacteric. Climacteric fruit typically increase biosynthesis of the gaseous hormone ethylene, and display a burst respiration at the onset of ripening. Fruit such as apple, banana, pears and tomato exhibit climacteric fruit ripening. Interestingly climacteric fruit span a wide range of angiosperms both dicots and monocot. Non-climacteric fruit, including strawberries, grapes and citrus fruit do not require climacteric respiration or increased ethylene for maturation. Surprisingly members of same (e.g. melon) or closely related (e.g. melon and water melon) species are reported to include both climacteric and non-climacteric types.

Genetic and molecular distinction between climacteric and non-climacteric fruit ripening are poorly understood. Nevertheless, it seems likely that non-climacteric phenotypes may represent mutations in ethylene synthesis or signaling as opposed to more complex distinction. Indeed non-climacteric melons are notoriously difficult to harvest compared with their climacteric counterpart because of reduced abscission, suggesting a defect in ethylene synthesis or response and a mature phenotype consistent with incomplete ripening.

Several mutants (spontaneous and induced) that affect fruit development and ripening have been identified and characterized particularly in tomato climacteric fruit).

Ripening in Climacteric fruits

Apple, Avocado, Banana, Cantalope, Mango, Olive, Papaya, Passion fruit, Peach, Pear, Plum and tomato are common climacteric fruits. These are also import commercial crops. In these fruits ethylene acts as an inducer of many genes associated with color change, changes in carbohydrate reserves, and softening of pulp. Ripening of climacteric fruit is induced by ethylene. However, something must signal ethylene induction before the climacteric

ethylene burst. It seems justified to assume that other factors that operate prior to induction of ethylene biosynthesis also control early developmental stages of ripening fruit.

Transgenic tomatoes, where, ethylene production is drastically curtailed by inserting the coding sequence of the ACC Synthase or the ACC oxidase gene in an antisense orientation, under control of strong promoter CaMV S 35, show no climacteric and do not ripen.

Ethylene production in plants results from methionine metabolism. The rate-limiting steps in fruit ethylene synthesis include the S-adenosylmethionine (SAM) to 1-aminocyclopropane-1-carboxylic acid (ACC) via ACC synthase (ACS) and the subsequent metabolism of ACC to ethylene by ACC oxidase (ACO). Both the ACC synthase and the ACC oxidase are encoded by multigene families. Anti-sense repression of ACS and ACO genes has clarified the role of these genes in regulating climacteric ethylene synthesis. It is also well known, however, that ethylene alone is not sufficient for ripening and that a developmental “competence” to respond to ethylene must be achieved.

This is obvious from the fact that immature fruit typically do not ripen in response to exogenous ethylene. Climacteric fruit ripening is regulated by developmental factors that must properly coordinate with ethylene synthesis. These include colorless non-ripening (*Chr*) ripening inhibitor (*rin*) and non-ripening (*nor*).

Valuable information has been generated through studies on developmental mutations that affect all aspects of the fruit ripening processes at least in tomato. These include colorless non-ripening (*Chr*), ripening-inhibitor (*rin*), non-ripening (*nor*). In these



Figure 24-Fruit ripening mutants of Tomato.(from left to right ,ripe fruit of wild type ,ripening inhibitor(*rin*), non-ripening(*nor*), Never-ripe(*Nr*)and Green-ripe(*Gr*).

mutants fruit ripening is severely impaired. These do not undergo an increase in ripening-related ethylene production and show inhibition of ripening related gene expression. In these mutants, however expression of ripening-related genes is partially restored but not ripening by application of ethylene. Thus these mutants remain ethylene responsive. Although a complete molecular biological and signal transduction pathway remain to be identified/defined. An important first step towards this goal came from the discovery that the *rik* locus encodes a MADS-box transcription factor necessary for regulating ripening. In other two mutants of tomato Green-ripe (*Gr*), and Never-ripe (*Nr*) studies have indicated that their reduced ripening results from decreased ethylene sensitivity. Light has been shown to affect carotenoid accumulation in plants. It has been shown that phytochrome mediated light signal transduction is required for normal ripe fruit pigmentation but it not affect other ripening attributes.

The change from a green fruit to ripe apple, banana and tomato involved a transition of chloroplasts to chromoplasts. Chlorophyll pigments and thylakoid membranes are broken down. A progressive accumulation of new carotenoid pigments occur in the plastids. The new carotenoids in tomato include β -carotene and lycopene. These provide the orange and red color for the ripe fruit respectively. Lycopene synthesis is induced by ethylene, and is shutt off by inhibitors of ethylene synthesis or perception.

Fruit of Banana, Kiwi fruit and mango synthesize and accumulate starch during development. During ripening these fruits hydrolyze starch and convert it into sugars. Fruits of Melon like systems continuously import sugars from other parts of the plant. During ripening, the fruits show an increase in the concentrations of sugars. Moreover, sucrose is hydrolyzed to hexoses. Ethylene-induced upregulation of mRNAs of enzymes involved in starch/sugar metabolism (such as sucrose phosphate synthase and acid invertase) occur during ripening in several fruits. These events change sweetness of fruit.

Production of organic acids (principally citric acid but also malic acid) and volatiles increase while fruits ripen. These combine to produce the unique flavor and aroma. Production of phenolics, provide astringency to unripe fruits. These have profound influence on the flavor and color of mature fruits.

Fruit texture changes drastically during ripening. The cell walls are degraded by increased activities of various hydrolyzing enzymes. Disruption of the cellulose hemicellulose and pectin networks is done by the increased activities of enzymes. The wall-loosening enzymes, such as endo-1, 4- β -glucanases (E Gases) and xyloglucan endotransglycosylases (XETs), are activated. Genes encoding expansive and XETs, and E Gases expressed during fruit ripening are induced by ethylene and down regulated by auxin. Activities of enzymes; Pectin methylsterase (PME) and polygalacturonase (PG) are enhanced during ripening fruits. These affect large changes in pectin structure. The production of PG is under developmental control. The enzyme is absent in green fruits and is synthesized *de novo* during ripening. Its production is controlled by ethylene.

The activities of stress/pathogen-inducible enzymes, superoxide dismutase (SOD) and catalase occur in ripening fruit. Both of these are known for antioxidant activities.

Ripening and non-climacteric fruits: Strawberry has been studied among the non-climacteric fruits. Majority of the changes that occur during ripening of non-climacteric fruits are similar to the changes that are seen in ripening of climacteric fruits.

Ripening of non-climacteric fruits (at least in strawberry) is not affected by exogenous ethylene and inhibitors of ethylene biosynthesis and ethylene response/action. Auxins retard/inhibit ripening related changes in strawberry. Grape berry and citrus fruits are two other non-climacteric fruits. Treatment with auxin retards ripening of these fruits. Citrus fruit is unusual; it is non-climacteric fruit, but carotenoid synthesis in the orange peel is regulated by ethylene.

Abscission of mature/ripe fruit, similar to leaves and flower pedicels is regulated by ethylene. Abscission is inhibited by auxins, cytokinins and cytokins.

Hormones: Integration of Responses to Regulate Plant Growth and Development

In June 1905, Ernest Starling, a Professor of Physiology at university of London, U.K. first used the word 'hormone'. In one of the four Croonian lectures on the chemical correlation of the function of body-delivered at the Royal College of Physicians in London. Starling, defined the word, derived from the Greek meaning 'to arouse or excite', as "the chemical messengers which speeding from cell to cell along blood stream, may coordinate the activities and growth of different parts of the body" (Jamshed R. Tata, 2005).

Initial studies on mechanism of hormone action suggested hormone-enzyme interactions as the basis of a common mode of action. However, by the end of 1950s, there were little enthusiasms and support for this idea. In the early 1940s, Rechimiel Levine had proposed that insulin controlled sugar metabolism by regulating its transport into the cell(s), which led several years later to the concept that protein and smaller peptide(s) signals interact with the cell membrane. The discovery of cyclic AMP (camp) by Earl Sutherland in 1956 as a 'second messenger' of adrenaline and glucagons, followed by the discovery that adenylyl cyclase, the enzyme that synthesizes camp, was located in plasma-membrane, further consolidated the view that the cell membranes was major site of action of many hormones. With the discovery of other molecules, such as inositol triphosphate, G Proteins and oncogenes, and the advent of gene cloning and sequencing technologies, it soon became possible to identify, characterize and locate several membrane bound hormone receptors in animals, microbes and plants. Binding of the ligand to these receptors initiates a cascade of protein phosphorylation and dephosphorylation in the cytoplasm, which eventually leads to the biochemical interactions and physiological actions of hormone(s). The first indication that hormonal signals regulate transcription rather than translation was provided in the early 1960s by studies showing that "puffing" – an index of intense transcriptional activation of polytenic chromosomes in the larval salivary glands of insect is regulated by the steroid moulting hormone ecdysone. The first evidence for the existence of nuclear receptors came in 1961 from Elwood Jensen and colleagues, who tracked radioactively labeled oestradiol-17 β in female sexual tissues and found that it forms a complex in the nucleus with a protein that fulfilled the criteria for receptors.

Concept Hormones in plants

Plant growth and development involves the integration of many environmental and endogenous signals that, together with the intrinsic genetic program, determine form and functions. Fundamental to this process are several growth regulatory substances collectively called the plant hormones or phytohormones. Decades of biochemical,

molecular biological and physiological studies have demonstrated that plants rely on diverse set of hormones that regulate every aspect of their biology.

The degree of specificity and redundancy among plant hormones has long been matter of debate and discussion particularly in the area of growth regulation. Analysis of biosynthetic and signaling mutants, in combination with exogenous hormone applications both *in vivo* and *in vitro* have concluded that gibberellins (GA), auxins and brassinosteroids (BR) regulate expansion along longitudinal axes and greatly influence plant structure and organ size. Ethylene, the gaseous hormone and cytokinins act primarily to increase cell expansion along transverse axes and greatly reduce the stature of dark-grown seedlings. Abscisic acid (ABA) has been shown to antagonize growth promotion by both GA and BR. In addition Jasmonic acid (JA), Salicylic acid (SA), Nitric oxide (NO), Polyamines (Pas) and plant sterols are also known to play essential role in modulation of growth and development in plants. During the past five years, it has become apparent that there are other novel signaling molecules, such as alkamides, glutamate and N-acylethanolamides that might play important roles in the regulation of morphogenetic and adaptive processes. These might be involved diverse processes, including seed germination, pathogenesis, modulation of plant architecture and response to abiotic factors.

Plant hormones are small organic molecules that affect diverse developmental processes. Alteration in hormone responses have been responsible for several important agricultural advances including the breeding of semi-dwarf varieties and increased grain production (Green Revolution in cereals). Unlike animal hormones, which are produced in specific organs, plant hormones are typically produced throughout the plant. Virtually every aspect of plant development from embryogenesis to programmed cell and senescence is under hormonal control. In general, this developmental control is exerted by controlling, cell cycle, division, expansion, differentiation and cell death. Diverse developmental processes can be controlled, including formation of the apical-basal and radial pattern, seed germination, and seed dormancy, determination of plant architecture, flowering, fruit ripening and shedding.

Recent work by various laboratories have revisited the question of hormone specificity and uncovered extensive crosstalk and signaling integration among growth-regulating hormones. A very high priority has been given to identification and characterization of the receptors that perceive the hormones. During 2005–2006, the receptors for the plant growth hormones, abscisic acid, auxin and gibberellins have been identified. These join the receptors that have previously been identified for brassinosteroids, cytokinins and ethylene.

Auxins

Auxins are natural hormones, mobile biochemicals which are transported from cell and organ to organ to signal and coordinate growth and development. The experiments of Charles Darwin on phototropic bending by grass coleoptiles in the 1880s led him to conclude that plants contained a mobile “influence” mediating growth. In the 1920s Fritz Went collected diffusate from coleoptiles and showed that the “influence” induced bending when applied to un-stimulated coleoptiles. In 1934, Kogl identified Indole-3-acetic acid (IAA) as the active compound.

The main natural auxin in all plants is IAA and it is synthesized primarily in dividing meristematic cells. Auxin, IAA is an absolute requirement for plant cell division, but through directed and non-directed transport, it also mediates control over many other key events during plant development. These include asymmetric growth during phototropism and gravitropism, apical dominance, fruit set and development, abscission, both lateral and adventitious root initiation, phyllotaxy, and vascular patterning. Plants have sophisticated machinery for polar auxin transport and auxin concentrations and in the plants are controlled. Some microorganisms have ability to synthesize auxins and they may perturb a host plant’s development and exploit the disturbance(s) for either pathogenesis or symbiosis. Exogenous application of auxin to plants or cell/tissues affects growth and development *in vivo* and *in vitro*. Auxins, both natural and synthetic, are in used in a range of agricultural and horticultural practices. The largest single market is as selective herbicides, but auxins are also applied as agrochemicals on fruit crops and for root induction during clonal propagation of nursery stocks.

Other Auxins

Besides, IAA, a small number of naturally occurring, related compounds have auxin-like activity. 4-chloroindole-3-acetic acid, phenylacetic acid, and indole-3-butyric acid (IBA) are the best characterized. A large number of heterogeneous group of synthetic compounds are found to have auxin activity. Some of the most widely used are : 2,4-dichlorophenoxyacetic acid (2,4-D), 2,4,5-trichlorophenoxyacetic acid (2,4,5-T), chloramben (Amiben), Picloram (Tordon/Grazon), Triclopyr (Garlon), 1-naphthaleneacetic acid (NAA), 2-Naphthoxyacetic acid (NOA) and Dicamba.

Biosynthesis of IAA

For many years it was thought that IAA was synthesized in apical meristems. However, recent evidence suggests that auxin is, or can be produced throughout the plant including the roots. Furthermore, not all IAA production is from *de novo* synthesis. In germinating seeds IAA is produced from breakdown of stored forms of the hormone, conjugates of amino acids, proteins, and sugars.

De novo auxin synthesis commences after seedling emergence. An aromatic amino acid, tryptophan is the precursor for a set of parallel IAA biosynthetic pathways, none of which are fully mapped. A few days later, another biosynthetic pathway is initiated, a tryptophan-independent pathway. This pathway remains the constitutive biosynthetic source of IAA throughout the rest of the life of a plant. When plants experience stress such as by wounding or during major developmental events like germination, then IAA synthesis is stepped up by switching on the tryptophan-dependent pathways.

Figure 25 -Tryptophan –Dependent Pathways of IAA Bioynthesis in Plants and Bacteria

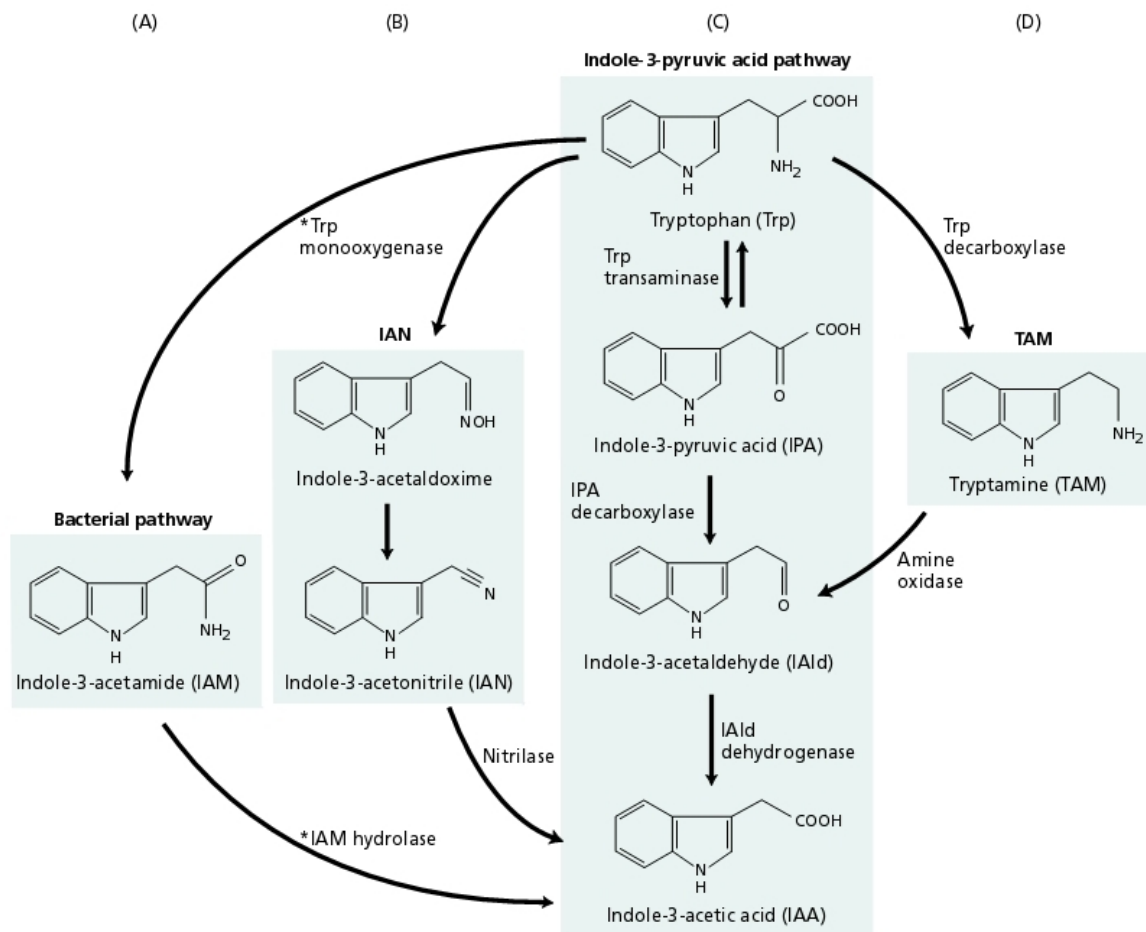

TRYPTOPHAN BIOSYNTHETIC PATHWAY

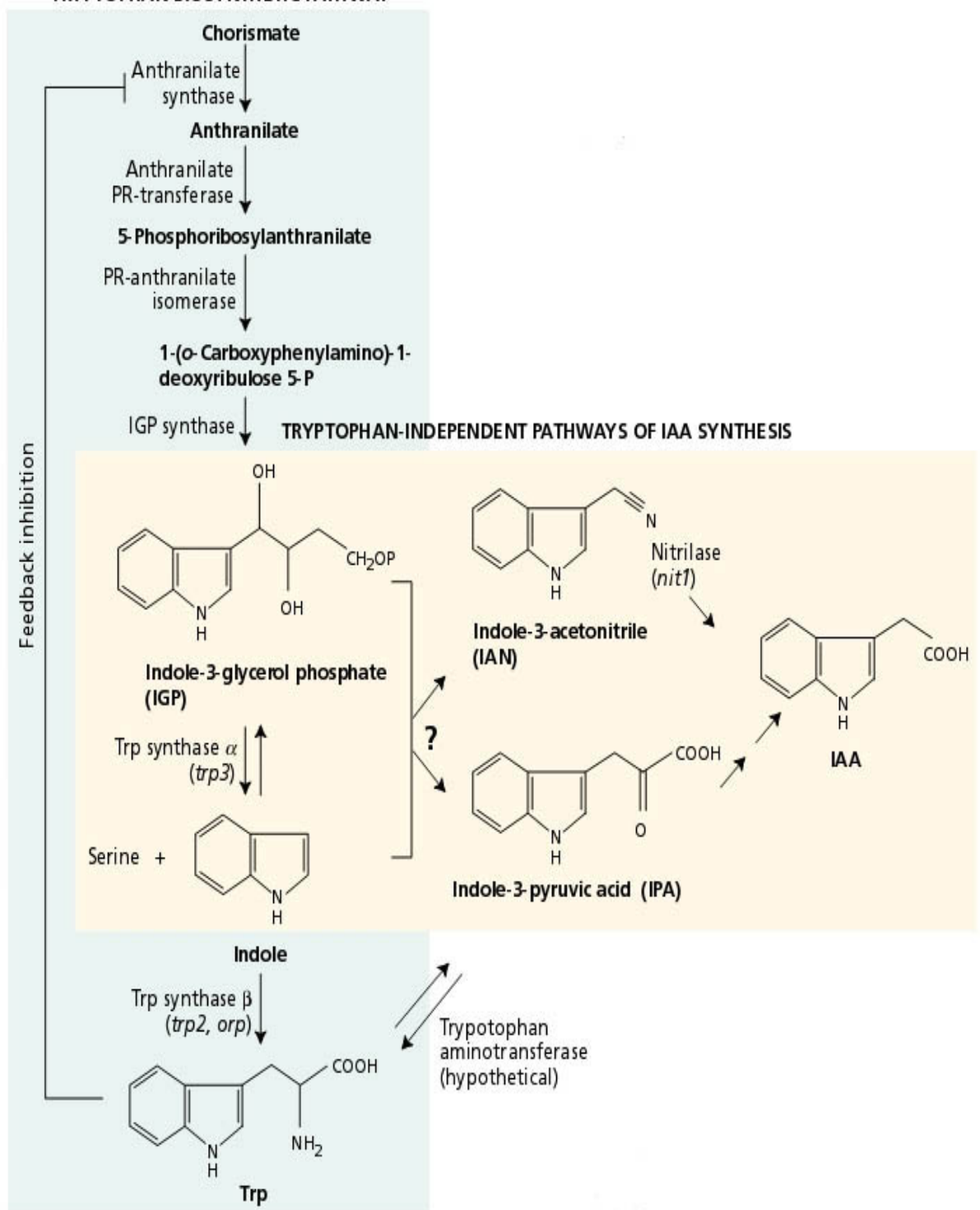

Figure 26 -Tryptophan –independent pathway of IAA biosynthesis in plants. The branch –point precursor for tryptophan-independent biosynthesis is uncertain (indole-3-glycerol phosphate or indole), and IAN and IPA are two possible intermediates.

The auxin IAA is made by certain microorganisms like pathogenic bacteria *Pseudomonas syringiae* and *Agrobacterium tumefaciense*. These organisms synthesize copious amounts of auxin from tryptophan. Evidence suggests that symbiotic mycorrhizal fungi produce auxin. These auxins then contribute to the changing morphology of the root system in these associations. Several Tryptophan–dependent pathways operate in plants. These are generally named after an intermediate. The indole–3–pyruvic acid (IPA) pathway, the indole–3–acetamide (IAM) pathway, the tryptamine pathway and indole–3–acetaldoxime (IAOx) are some of the major pathways for auxin synthesis in plants/microbes.

Auxin transport

All plant hormones are moved around the plant in the vasculature where, once loaded, they move passively as passenger molecules. Auxin is special in that plants also have a polar system to move IAA vectorally. Polar auxin transport requires energy and contributes to many of the important auxin–dependent responses such as apical

dominance and gravitropism. The consequences of polar auxin transport are that certain cells (or tissues) receive extra auxin. Polar transport functions at cellular levels. It is believed that this is affected by the combined activities of both auxin influx proteins and auxin efflux proteins. The influx carrier gene is now known as AUX 1. The AUX 1 protein is a member of the amino acid transporter protein super family. It is an integral membrane protein. The first efflux carrier gene was identified from plants with extreme flower morphology. Pin-like organ formed with no development of flower parts. This morphology gave rise to the name PIN for the gene family and there several PIN genes in *Arabidopsis*. The efflux proteins act to pump auxins out of cells to effect auxin gradient and confer directional information. These proteins sit in the plasma membrane. The speed of polar auxin transport is generally measured at about 10–20 mm h⁻¹. Many of the auxin-driven responses fail if auxin is absent or in excess, or if polar auxin transport is defective. It is, therefore, suggested that auxin delivery is, perhaps, as important as the hormone itself. As a result, auxin physiology has benefited from the use of drugs that act specifically to inhibit polar auxin transport. Naphthylphthalamic acid (NPA) is the most specific auxin transport inhibitor and this has been used widely. Triiodobenzoic acid (TIBA) has also been used, but has additional activities. Recently 1-naphthoxyacetic acid has been identified as a useful tool to inhibit auxin uptake.

Auxins play a pivotal role throughout the development of a plant, regulating the expression of many genes during plant growth. Whole-plant responses such as tropism and epinasty, apical dominance and branching, adventitious root initiation and wound responses, and cellular processes, such cell expansion, division and differentiation, are regulated or influenced by auxins. Vascular patterning, embryonic patterning, organ patterning and fruit growth and ripening are also affected by auxins.

The largest commercial exploitation of any plant hormone has been in the use of synthetic auxins as selective herbicides. The first phenoxyacetic acid auxins, such as 2,4-D, were developed during the 1940s. Auxins were the active defoliant in “Agent Orange” and phenoxy auxins are still used to control brush wood.

Auxin receptors and signal transduction

In between embryonic patterning and senescence, only a few processes can be named in which there is not some involvement of auxins as a hormonal signal. The quest for the explanation of how auxin works has been robust. This has been existing since ‘the power of movement in plants’ was published by Charles Darwin and the identification of the active chemical as IAA. Receptors for plant hormones such as auxins have been sought keenly particularly after the discovery of first protein receptors for animal hormones. Numerous candidate receptors have been identified and characterized. Auxin-binding protein 1 (ABP 1) has been studied most extensively. However, the identification of TIR 1 as a receptor that interact with transcription factors is a big step forward in the quest to know about auxin action. The ‘Transport Inhibitor Response 1’ (TIR 1) gene was identified in genetic screen for *Arabidopsis* plants tolerant to compound that blocks auxin transport. However, now it is known that TIR 1 functions in auxin responsiveness, and not in auxin transport. The TIR 1 gene translates into a protein with recognizing motifs including an F-box domain. The TIR 1 protein becomes part of an important ubiquitination complex that tags other proteins for degradation. TIR 1 specifically targets a set of auxin-regulated transcription factors. The recent work has demonstrated that TIR 1 itself is also the binding site for auxin making it as one of the auxin receptor(s). TIR is soluble and resides in nucleus.

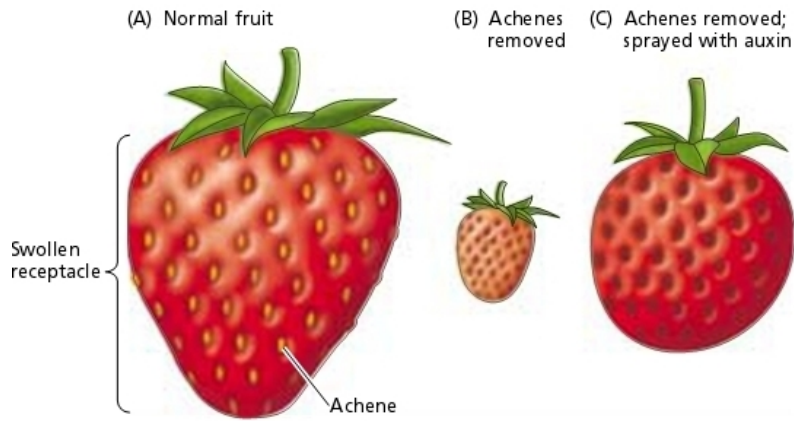

Figure 27 - (A) the strawberry “fruit” is actually a swollen receptacle whose growth is regulated by auxin produced by the “seeds”, which are actually achenes the true fruits. (B) when the achenes are removed, the receptacle fails to develop normally. (C) Spraying the achenes-less receptacle with IAA restores normal growth and development.

It has been suggested that TIR 1 acts as an auxin receptor, not as the auxin receptors. Auxin response factors (ARFs) are a family of transcription factors. The ARFs bind specifically to the auxin response elements (Aux Res) within promoters of primary auxin responsive genes and function as activators or repressors. The ARFs contain three domains. One of these, a conserved N-terminal domain binds to DNA. The C-terminal domain of the ARFs forms a protein complex with auxin/IAA through homodimerization or heterodimerization. Thus the modes of actions of auxins(s), the plant morphogens and auxin signal transduction pathways (mechanisms) are now better understood. It seems likely that the TIR 1 system can account for a large part of the repertoire of auxin-mediated responses, but may be not all.

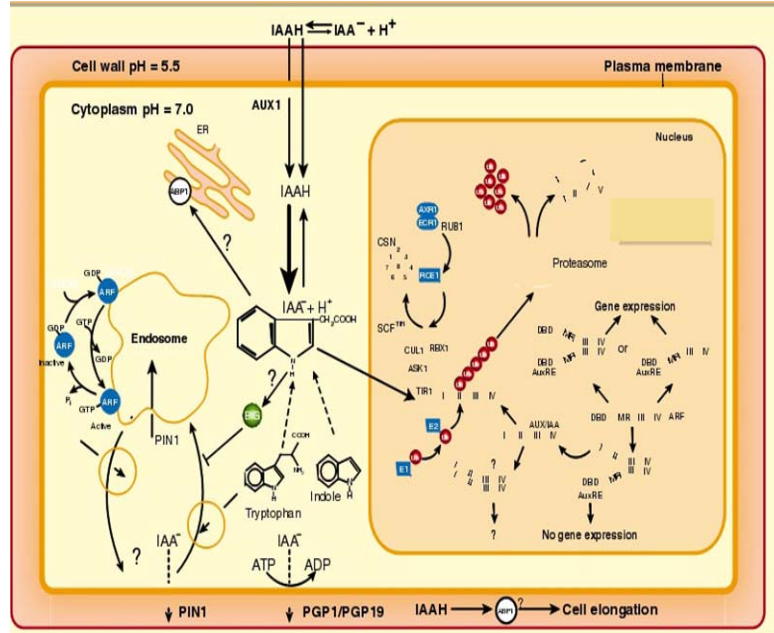

Figure 28 -Auxin Signaling Pathway in Plants.

Abscisic Acid (ABA)

Plants are immobile and therefore need to cope effectively with environmental stresses. To this end, plants have stress hormone, abscisic acid (ABA). Plants use this hormone also for regulating adaptive features that delay growth (nongrowth) until environmental conditions are favorable. The phenomena of seed and bud dormancy are caused by inhibitory actions of ABA.

During the early stages scientists attempted to extract and isolate substances that inhibited growth and were associated with senescence/ abscission and bud dormancy. Dormant buds alongwith other variety of tissues were tested. Chromatography and bioassays were used for separation and identification of a group of growth-inhibiting compounds.

This resulted in purification of dormin from leaves of sycamore collected in early autumn, when the trees were entering dormancy. The dormin was found to be chemically identical to a substance that caused the abscission of cotton fruits, abscisin II. This compound was named abscisic acid (ABA), as it causes abscission in plants.

It is now known that gaseous hormone ethylene incites abscission and ABA-induced abscission of cotton fruits is due to an ability of ABA to stimulate ethylene production.

ABA is a ubiquitous hormone in tracheophytes. It has also been detected in mosses and ferns. It occurs in every major living tissue from the root cap to the apical bud though with varying ABA concentrations. Several fungi produce ABA as a secondary metabolite. ABA is found in all divisions and classes of algae.

Biosynthesis of ABA

ABA is synthesized in almost all cells that contain chloroplasts or amyloplasts. The molecular basis of ABA metabolism was established by genetic approaches. Most of Viviparous mutants of maize exhibit defective carotenoid biosynthesis. These mutants are albino phenotypes with a reduced ABA level. In contrast in a variety of plant species phenotypes of mutants defective in downstream of xanthophylls cycle are most likely due to ABA deficiency which is characterized by a wilted plant and production of non-dormant seeds.

ABA belongs to a class of metabolites known as isoprenoids (also called terpenoids). They derive from a common five-carbon (C₅) precursor, isopentenyl diphosphate. Earlier it was thought that all isoprenoids were synthesized from mevalonic acid (MVA). However recently, an alternative pathway to synthesize IDP was discovered. Plastidic isoprenoids (including carotenoids) originate from IDP synthesized this MVA-independent pathway called the 2-C-methyl-D-erythritol-4-phosphate (MEP) pathway. 2-C-methyl-D-erythritol-4-phosphate (MEP) is derived from pyruvate and glyceraldehyde-3-phosphate. Although ABA contains 15 carbon atoms, in plants it is not derived directly from the C₁₅ sesquiterpene precursor, farnesyl diphosphate (FDP). ABA is rather formed by cleavage of C₄₀ carotenoids originated from the MEP pathway. Evidence for ABA biosynthesis from

carotenoids has been obtained by ^{18}O labeling experiments molecular genetic analysis of auxotrophs and biochemical studies. Cyclization and hydroxylation of all-trans-lycopene via β -carotene produce zeaxanthin as a trans-isomer. Violaxanthin and neoxanthin, the cis-isomers are synthesized from zeaxanthin. This step is catalyzed by zeaxanthin epoxidase (ZEP) via the intermediate antheraxanthin, sesquiterpene precursor, farnesyl diphosphate (FDP). ABA is rather formed by cleavage of C_{40} carotenoids originated from the MEP pathway. Evidence for ABA biosynthesis from carotenoids has been obtained by ^{18}O labeling experiments molecular genetic analysis of auxotrophs and biochemical studies. Cyclization and hydroxylation of all-trans-lycopene via β -carotene produce zeaxanthin as a trans-isomer. Violaxanthin and neoxanthin, the cis-isomers are synthesized from zeaxanthin. This step is catalyzed by zeaxanthin epoxidase (ZEP) via the intermediate antheraxanthin.

The cis-isomers of violaxanthin and neoxanthin are cleaved to a C_{15} product, xanthoxin, and a C_{25} metabolite by an enzyme Nine-cis-epoxycarotenoid dioxygenase (NCED). NCED proteins from various plant species are chloroplast-targeted (nuclear gene-encoded). Xanthoxin is presumed to migrate from plastid to cytosol. ABA, the biologically active form, is produced in cytosol from cis-xanthoxin by two enzymatic steps via the intermediate abscisic aldehyde. An enzyme abscisic aldehyde oxidase catalyzes the final step of ABA biosynthesis to oxidize the abscisic aldehyde to yield the carboxylic acid.

Vascular tissues are probably the main site of ABA biosynthesis in unstressed plants and ABA and its precursors might be synthesized in the vascular tissues and transported to target cell such as stomata. ABA biosynthesis is also active in guard cells. ABA can be conjugated with glucose, which represents an inactive pool of ABA. An ABA-specific β -glucosidase, AtBG 1 produces bioactive ABA by cleavage of glucose-conjugated-ABA.

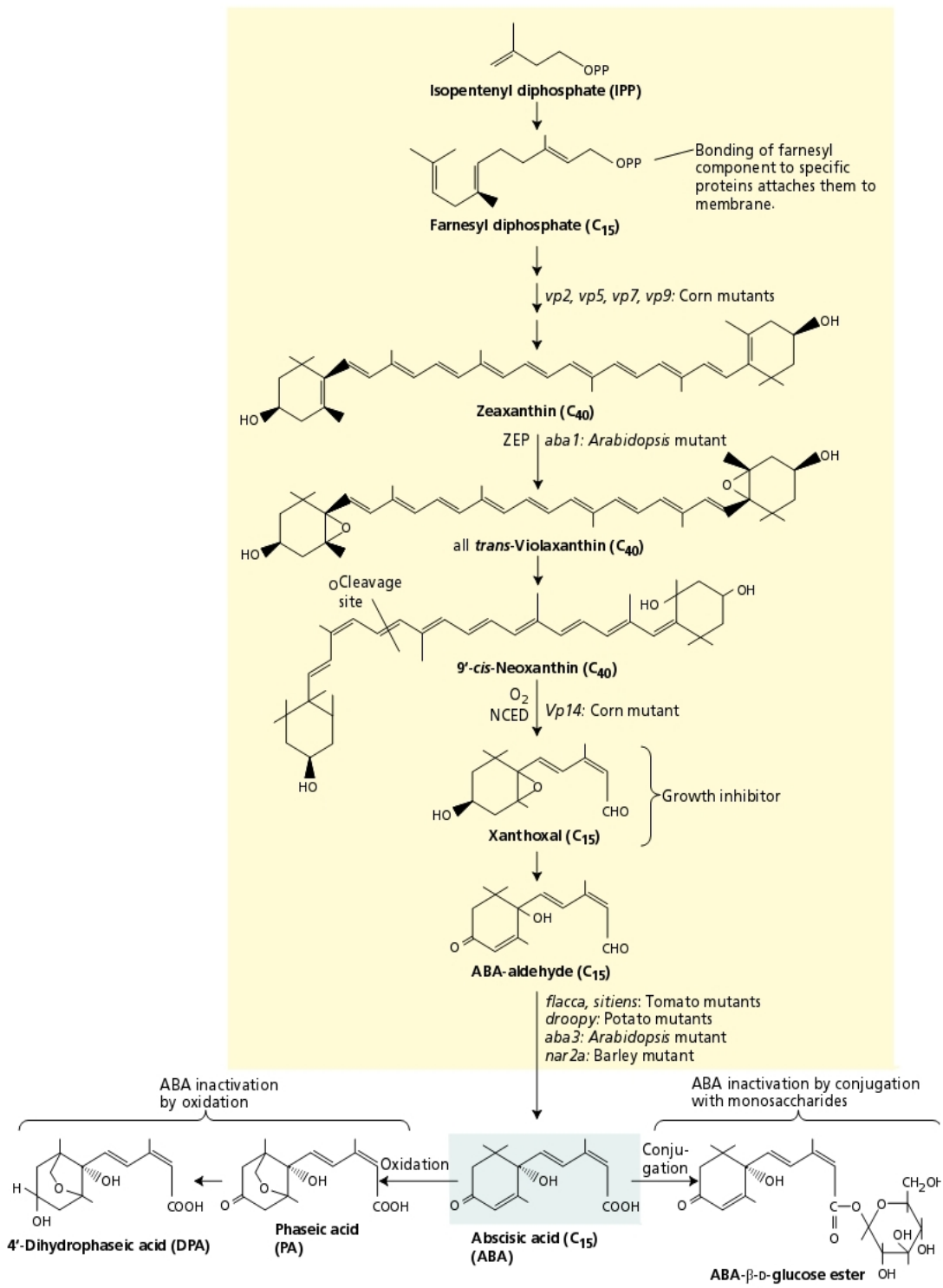
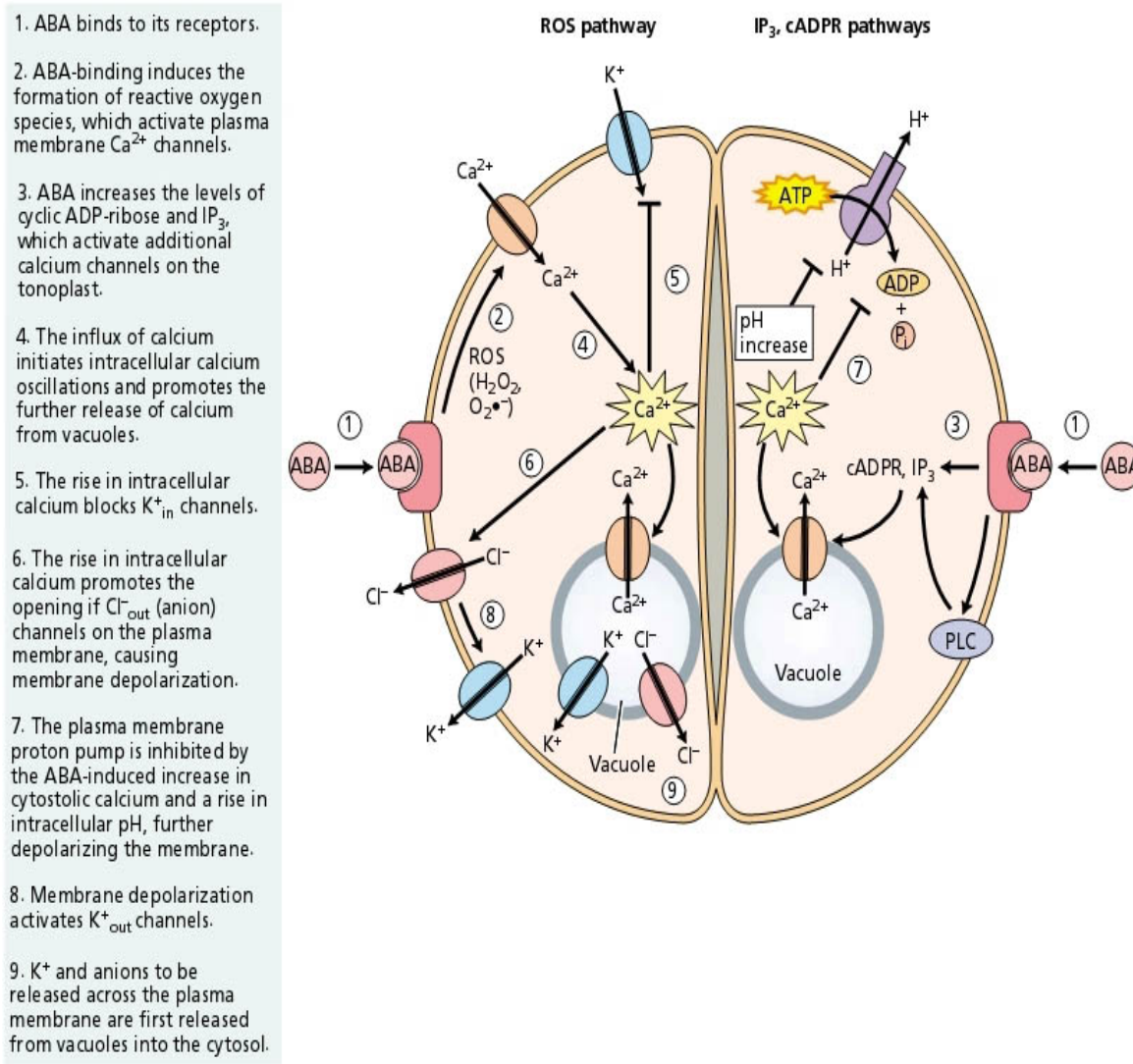

Figure 29 -ABA biosynthesis and metabolism .in higher plants, ABA is synthesized via the terpenoid pathway .some of the ABA-deficient mutants that have been helpful in elucidating the pathway are shown at the steps at which they are blocked. The pathway for the ABA catabolism includes conjugation.

Mechanism of action of ABA

ABA regulates many agronomically important aspects of plant development, including the synthesis of seed storage proteins and lipids, the promotion of seed desiccation tolerance and dormancy, and the inhibition of the phase transitions from embryonic to germinative growth and from vegetative reproductive growth (floral initiation), root development and fruit development. In addition, ABA mediates some aspects of physiological responses to environmental stresses such as drought – or osmotica–induced stomatal closure the induction of tolerance of water, salt, hypoxic, and cold stress and wound and pathogen responses.

Figure30 Simplified model for ABA signaling in stomata guard cells.



The stomatal responses are very fast and occurring within minutes and involving changes in the activity of various signaling molecules and ion channels. The rest of the responses are slower and require changes in gene expression. Both the sets of responses, however

Figure31- Redistribution of ABA in the leaf resulting from the alkalization of the xylem sap during water stress

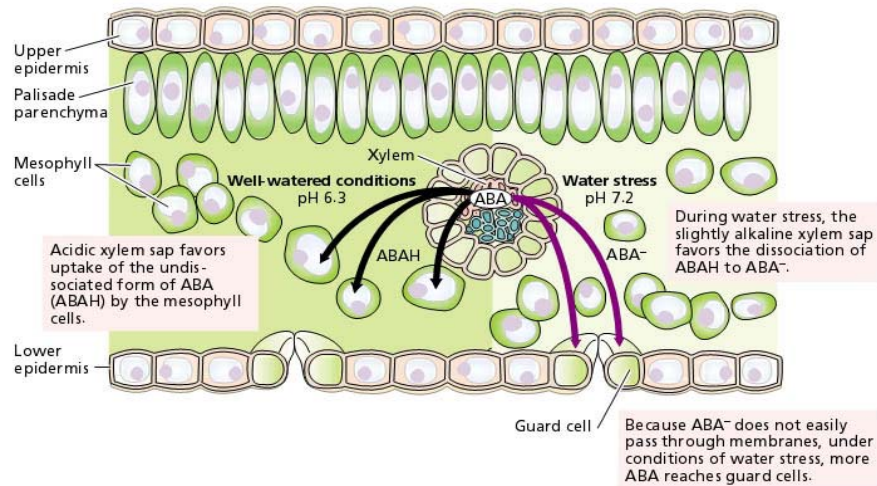

clearly require the action of common signaling elements. Several individual mutants (e.g. the *Arabidopsis* ABA-insensitive *abi 1* and *abi 2* mutants and the ABA-hypersensitive *era 1* mutant) affect subsets of both types of responses. Furthermore, cell biological studies have indicated involvement of common classes of secondary messengers or components of phosphorylation cascades in both fast and slow responses to ABA. ABA and GA have antagonistic effects on several developmental processes in plants.

The mechanisms by which ABA regulates various physiological processes in plants are not fully understood. Genetic approaches have characterized several down stream components of ABA signaling. Earlier studies indicated that several ABA response genes encode RNA-binding or RNA-processing proteins. Studies on mutants have linked RNA metabolism to ABA signal production through the modulation of RNA processing, splicing, stability and degradation. Recently an *Arabidopsis* protein that regulates flowering time has been identified as ABA receptor. FLOWERING TIME CONTROL LOCUS A (FCA) is a nuclear ABA-binding protein specific to plants, that promote flowering preventing the accumulation of mRNA encoding FLC, a MADS transcription factor that is a potent repressor of the floral initiation. The identification of the RNA-binding protein FCA as a receptor for ABA demonstrates a new level of hormonal signaling that involves post-transcriptional regulation. It has been suggested that not only do additional ABA receptor(s) exist; but also possible distinct signaling pathways.

Cytokinins

Cytokinins are N⁶-substituted adenine derivatives that generally contain an isoprenoid derivative side chain. These play role in almost all aspects of plant growth and development, including cell division, sink/source relationship, vascular development, chloroplast differentiation, seed germination, de-eliolation, apical dominance, flower and fruit development, plant pathogen interactions and senescence.

Several natural products ranging from yeast extract, tomato juice, liquid endosperm of coconut (coconut milk/water) were used and evaluated in efforts in attempts to start growth and sustain the proliferation of plant tissues in culture.

Figure32 The regulation of growth and organ formation in cultured tobacco callus at different concentration of auxin and kinetin.

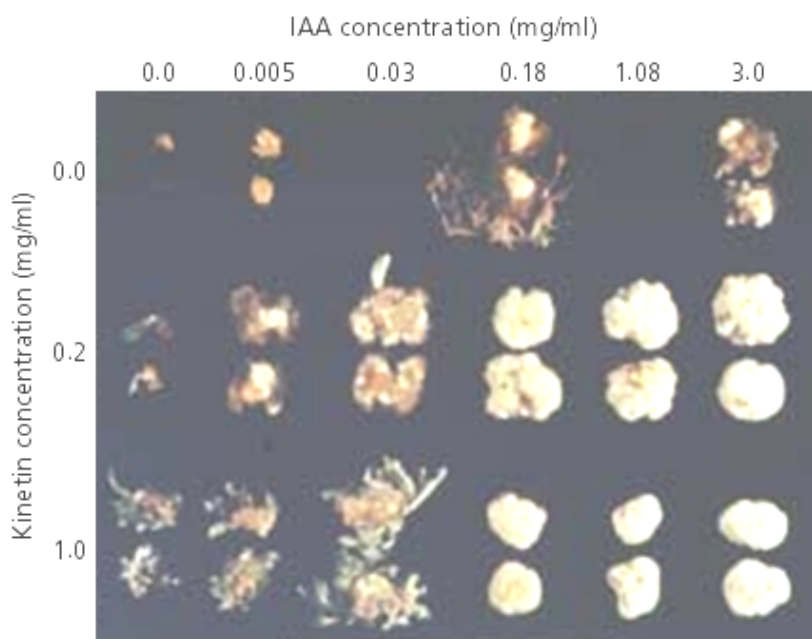

At low auxin and high kinetin concentration

(Lower left) buds develop. At high auxin and low kinetin concentration (upper right) roots develop. At intermediate or high concentration of both hormones (middle and lower right) undifferentiated callus develop.

Philip Whit's culture medium was supplemented with an auxin and coconut milk. This nutrient medium supported the continuous cell division of cells of numerous types of tissues friend plant species leading to formation of callus (unorganized mass) tissues. These studies indicated that coconut milk contains substance(s) that stimulate(s)

cells to enter and remain in the cell division cycle. Later on it was found that coconut milk contain the cytokinin, zeatin. This finding was late. Prior to that, the cytokinins were discovered. The first cytokinin to be discovered was the synthetic analogue, kinetin. Folk Skoog and coworkers of University of Wisconsin observed that the nucleic acid base adenine had a promotory effect on growth of tobacco pith tissue on culture medium. So, they tested the possibility of nucleic acid stimulating cell division and growth in the pith tissues. Ultimately a powerful cell division promoting effect was found to be associated with autoclaved herring sperm DNA. A small molecule was characterized and identified from the autoclaved DNA. This was named kinetin. It was shown to an adenine (or aminopurine) derivative, 6-furfurylamino purine (Miller et al. 1955). Extracts of immature endosperm of corn (*Zea mays*) were found to contain kinetin-like activities the ability to stimulate cell division in mature plant cells in culture. Letham isolated the molecule responsible for this activity in the immature endosperm of maize. This compound was identified as trans-6 (4-hydroxy-3-methyl but-2-enylamino) purine, which he termed zeatin. In higher plants, zeatin occurs in both the cis and the trans forms which can be interconverted by zeatin isomerase enzyme. Zeatin is the most prevalent cytokinin in higher plants. Many other substituted aminopurines have been isolated from many plants and bacteria. These are show N⁶-(Δ^2 -isopentenyl)-adenine (ip) and Dihydrozeatin (DZ). Cytokinins can be present in the plants as riboside(s), ribotide(s), and glycoside(s). Many chemical compounds have been synthesized and tested for cytokinin activities. Some of these are benzyladenine (BA)/benzyl aminopurine (BAP). In addition there are synthetic cytokinins derived from diphenylurea (DPU) that are structurally unrelated to the adenine type cytokinins. The diphenylurea type cytokinins such thidiazuron is used commercially as defoliant and as a herbicide.

Biosynthesis of cytokinins

Mature tRNA from most organisms (plants included) contains cis-zeatin as a modified base. The breakdown of + RNA was originally suggested/accounted as a possible mechanism for cytokinin biosynthesis. It was thought that the released cis-zeatin may be converted to active trans-zeatin by zeatin isomerase. However, it was realized that

the slow turnover rate of +RNA is not sufficient to account for the amount of cytokinins present in plants. In *Dictyostelium discoideum*, it was discovered that an enzyme activity converts AMP and dimethylallyl pyrophosphate (DMAPP) to the active cytokinin iPMP (isopentenyladenosine-5'-monophosphate). Cytokinin biosynthesis is regulated by ISOPENTENYL TRANSFERASE (IPT) gene. The *ipt* gene has been shown to uncode an enzyme with similar activity in several bacterial species including *Agrobacterium tumefaciens*. IPT activity was also detected in extracts of plant tissues. *In silico* searches of the genome sequences of *Arabidopsis* revealed the presence of several (Nine) *ipt* homologues designated as AtIPT 1 to 9. The presence of the IPT genes in plants provided clues that these genes may encode the cytokinin biosynthetic enzyme(s). The proteins encoded by these genes were expressed in *E. coli*. These genes encoded proteins capable of synthesizing free cytokinins. Cytokinins are synthesized in root tips of the plants. These are transported to the shoot(s) via xylem. Transport of zeatin riboside from the root to the shoot is regulated by the cues derived from the shoot. Cytokinins regulate cell division, and components of cell cycle. The auxin cytokinin ratio regulates morphogenesis in the cultured tissues. Cytokinins modify apical dominance and promote growth of lateral/axillary buds. Cytokinins promote bud growth and shoot proliferation. Cell expansion in leaves and cotyledons is promoted by cytokinins. These compounds promote development of chloroplast and movement of nutrients. Leaf senescence is delayed by the cytokinins. Vascular development is regulated in several plant species by the cytokinins.

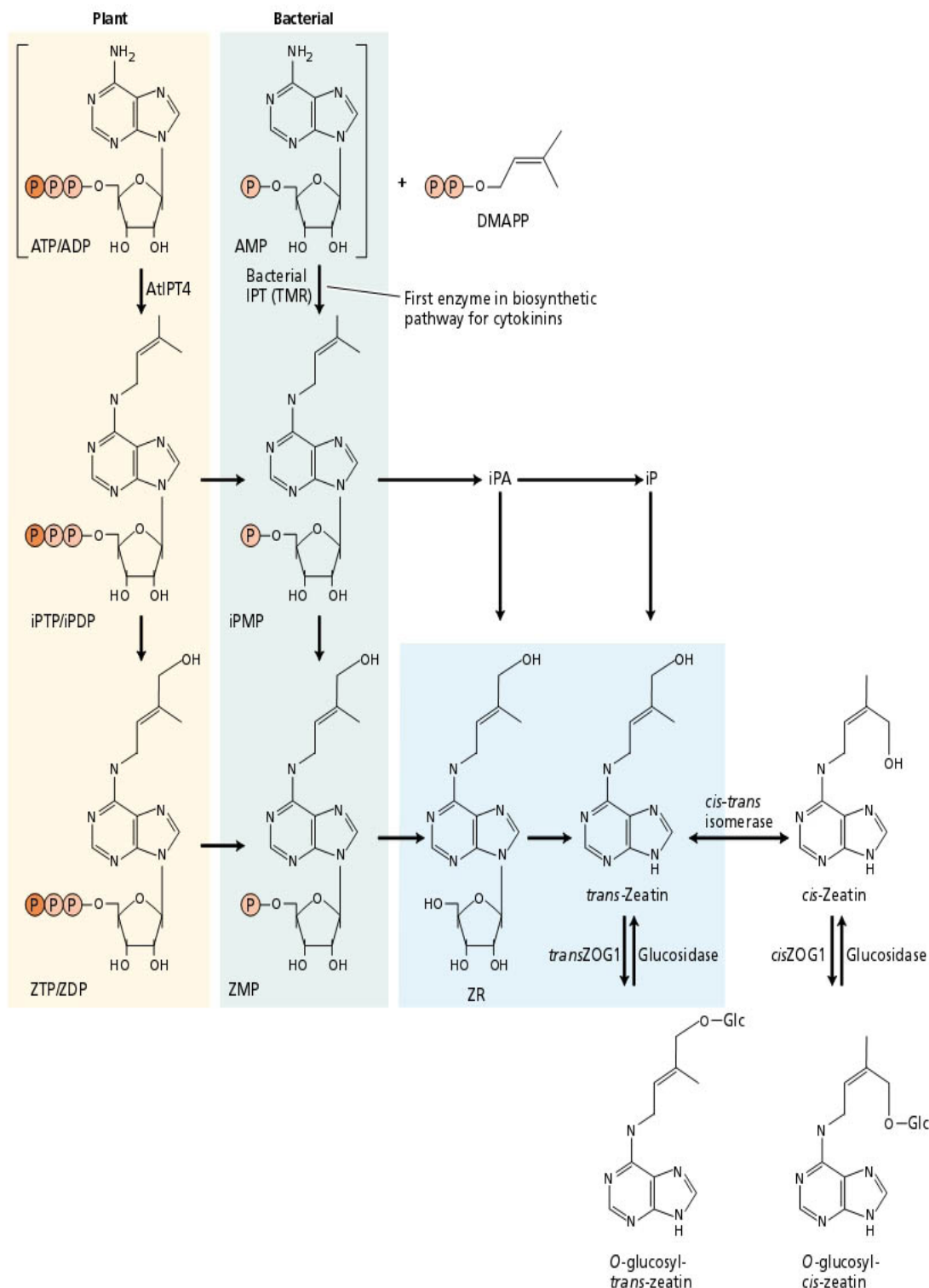

Figure 33 - Biosynthetic pathway for cytokinin biosynthesis. The first committed step in cytokinin biosynthesis is the addition of isopentenyl side chain from DMAPP to an adenosine moiety.

Cytokinin over production is implicated in formation of genetic tumors in tobacco species. The *ipt* gene(s) from the *Agrobacterium* Ti-plasmid(s) are introduced into many species of plants. This result, in over production of cytokinins resulting in abnormal growths and tumor formation and phenotypes.

Cytokinins are used in micropropagation industry for large scale plant production through bud activation, and shoot proliferation.

Cytokinin Signaling

Recent studies have demonstrated that in plants cytokinin signaling pathway is similar to bacterial and yeast two-component signal transduction pathways; specifically to His-Asp multistep phosphorelays, which are comprised of sensor kinases, histidine phosphotransfer proteins and response regulators. The cytokinin are perceived (by sensors) in plants (at least in *Arabidopsis*) by three related receptor (sensor) histidine kinases. The sensor proteins HISTIDINE KINASE 2 (AHK 2), AHK 3, AHK 4/CYTOKININ RESPONSE 1 (CRE 1)/WOO- DENGLEG (WOL) contain a conserved extra-cellular cytokinin-binding domain called the CHASE (Cyclases/histidine kinases associated sensory extracellular) domain, a histidine-kinase domain and a receiver domain. CRE-family receptors and AHKs are positive, redundant elements in the cytokinin primary signal transduction pathway.

Five Histidine-phosphotransfer proteins (AHP) are encoded by AHP genes in *Arabidopsis*. These are expressed ubiquitously, and their transcription is not affected by cytokinin treatments. The AHPs interact with various Histidine sensor kinases and *Arabidopsis* response regulators (ARRs). The AHP play role in mediating phosphotransfer among these (AHKs and ARR) elements. Several of the AHPs have been shown to accumulate in

1. Cytokinin binds to CRE1, which is likely to occur as a dimer. Cytokinin binds to an extracellular portion of CRE1 called the CHASE domain. Two other hybrid sensor kinases (AHK2 and AHK3) containing a CHASE domain are also likely to act as cytokinin receptors in *Arabidopsis*.

2. Cytokinin binding to these receptors activates their histidine kinase activity. The phosphate is transferred to an aspartate residue (D) on the fused receiver domains.

3. The phosphate is then transferred to a conserved histidine present in an AHP protein.

4. Phosphorylation causes the AHP protein to move into the nucleus, where it transfers the phosphate to an aspartate residue located within the receiver domain of a type-B ARR.

5. The phosphorylation of the type-B ARR activates the output domain to induce transcription of genes encoding type-A ARRs.

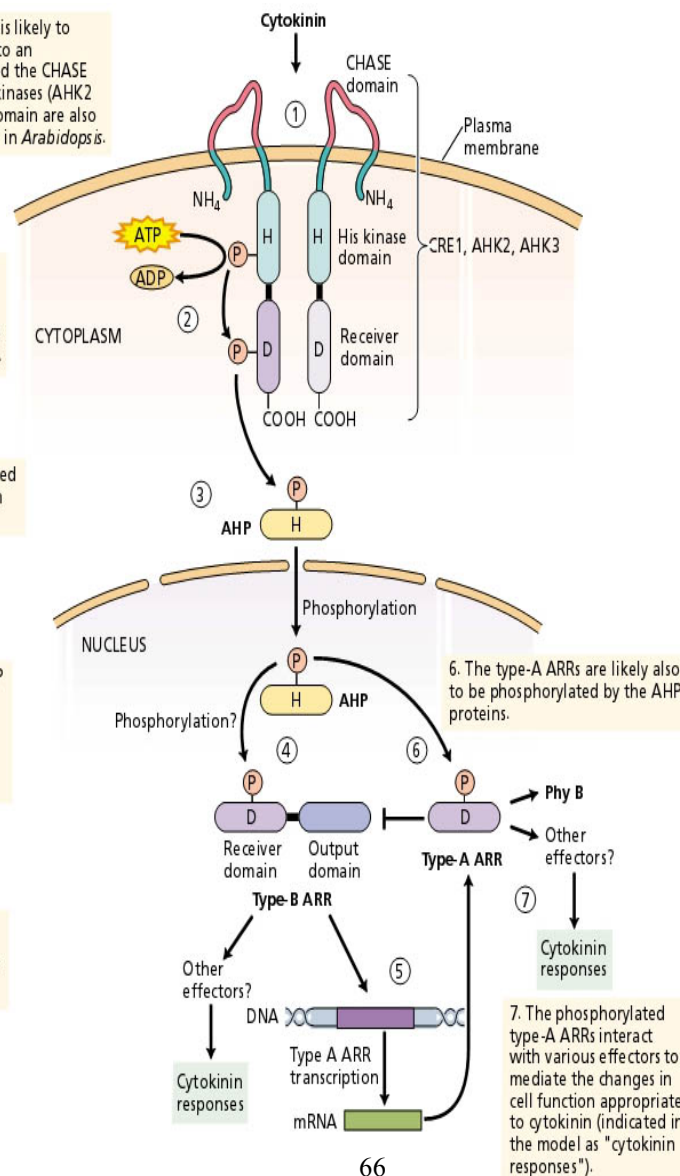

the nucleus of cytokinin-treated cells. The AHPs, are positive but redundant elements in the cytokinin primary signal transduction pathway. *Arabidopsis*, 23 ARR genes are known to respond to cytokinins.

Transcription of the type-A of these ARRs is rapidly elevated in response to exogenous cytokinin. The transcription of type-B ARR genes is not altered by cytokinins. The type-B ARR proteins have DNA-binding GARP domain. The type-B ARRs are transcription factors that localize to the nucleus. These are positive elements in cytokinin signaling. The type-A ARRs negatively regulate cytokinin signaling.

7. The phosphorylated type-A ARRs interact with various effectors to mediate the changes in cell function appropriate to cytokinin (indicated in the model as "cytokinin responses").

Figure 34 Model for Cytokinin signaling

Ethylene–The Gaseous Plant Growth Regulator

Ethylene is a gaseous hormone. Ethylene has the simplest structure among all the known plant growth substances.

History of discovery

Ethylene has been used in practice since the Ancient Egyptians, who would gas figs in order to stimulate ripening. The ancient Chinese would burn incense in closed rooms to enhance the ripening of pears. It was in 1864, the leaks of street lights showed stunting of growth, twisting of plants, and the abnormal thickening of stems the triple response. About 105 years ago in 1901, Dimitry Neljubow, a graduate student at the Botanical Research Institute of St. Petersburg in Russia found that ethylene present in the air of laboratory from coal gas was responsible for reduced hypocotyl elongation, increased lateral growth, and abnormal horizontal growth in the dark-grown seedlings of pea.

In 1910, H.H. Cousins published observations which indicated that ethylene was a natural product of plant tissues. Probably, the observation that “emanation” from oranges stored in chamber caused the premature ripening of banana when gases were passed through a chamber containing fruit. This observation was probably an artifact but the conclusion was correct. Oranges produce little ethylene as compared to other fruits, such as apple when ripening. Probably oranges used by Cousins were infected with the fungus *Penicillium* which produces ethylene.

Doubt (1917) discovered that ethylene stimulated abscission. Gane (1934) identified ethylene as a chemical, as a natural product of plant metabolism. In 1935, Crocker proposed that ethylene was the plant hormone responsible for fruit ripening as well as inhibition of vegetation. Introduction of gas chromatographic tools facilitated research on ethylene metabolism in plants. During the 20th century ethylene has been shown to affect several developmental processes, such as the triggering of abscission, fruit ripening and relaying of responses to external stress factors, such as pathogen responses and wounding.

All higher plants produce ethylene which serves as an important regulator of growth & development and disease resistance. Ethylene is known to affect following processes:

- A. Stimulation of (i) release of bud dormancy, (ii) shoot and root growth and differentiation, (iii) leaf and fruit abscission, (iv) flower induction in Bromeliads, (v) flower and leaf senescence, (vi) fruit ripening.
- B. Induction of femaleness in dioecious flowers.
- C. Man have role in adventitious root formation.
- D. Regulation of responses to abiotic stresses (such as those induced by flooding or drought and) and biotic stresses such those induced by pathogens.

Ethylene has also been implicated in the development of processes such as the formation of the apical hook in dark-grown seedlings (this hook protects the apical meristem as the young seedling forces its way through soil towards the light), the regulation of cell expansion and flower development.

Biosynthesis of Ethylene

Shang Fa Yang discovered the ethylene, biosynthesis pathway. Incubation of apple plugs with labeled methionine in the absence of oxygen resulted in the accumulation of an intermediate, which was identified as 1-aminocyclopropane-1-Carboxylic acid (ACC). Another product of this reaction was methylthioribose, suggesting that 5-adenosylmethionine (SAM) was the precursor of ACC synthesis. Ethylene is produced by most plant tissues. Biosynthesis of this hormone (Yang Cycle of ethylene biosynthesis) begins with SAM which is converted to ACC by an enzyme ACC synthase. The gene for this enzyme is part of multigene family. Transcription of different forms of the enzyme is induced under different environmental or physiological conditions. The next step is the conversion of ACC to ethylene by ACC oxidase, which is present in most tissues at very low levels. ACC oxidase genes are also part of multigene family, and the proteins are modified post-translationally, giving rise to different isoforms.

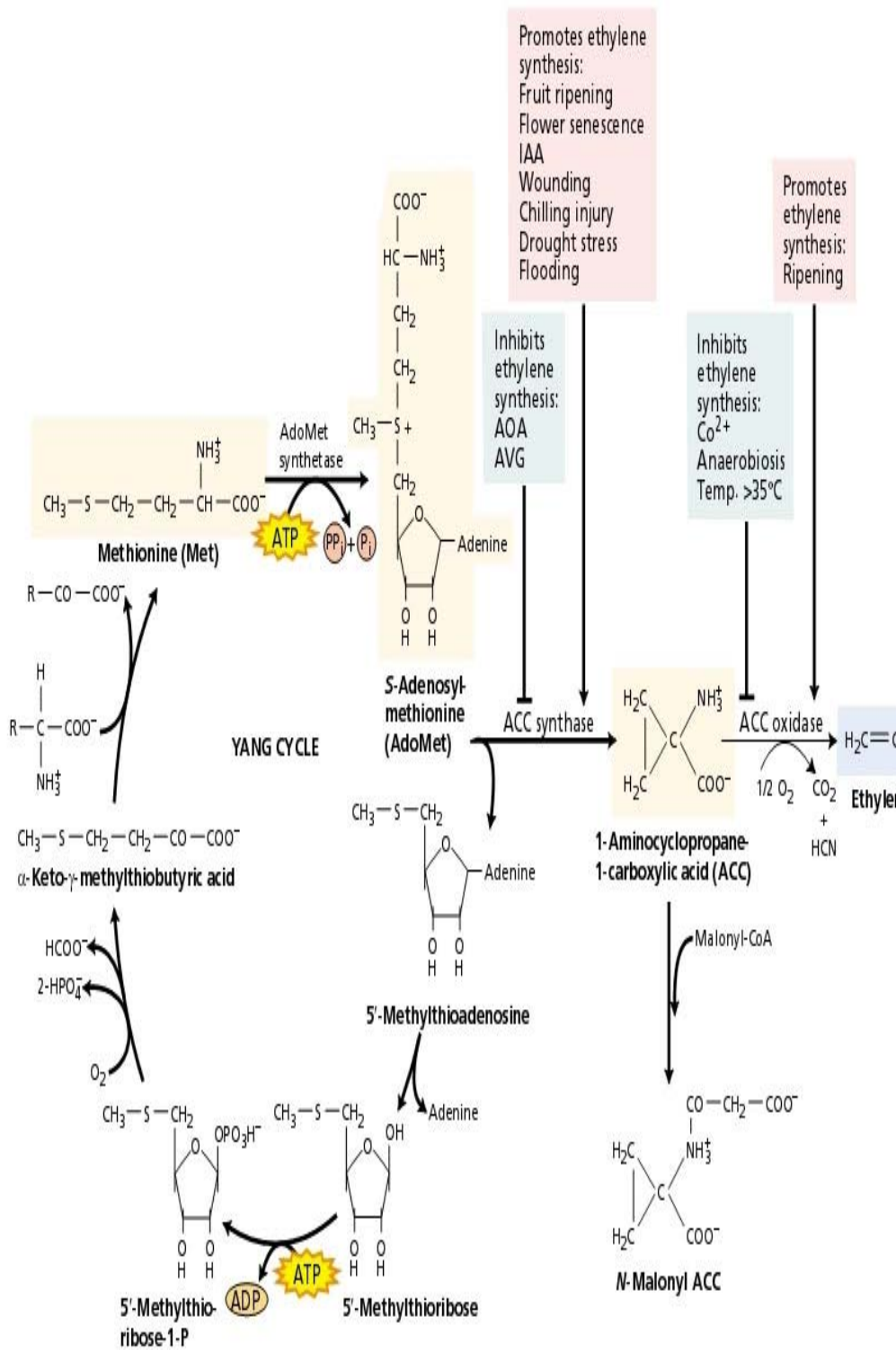
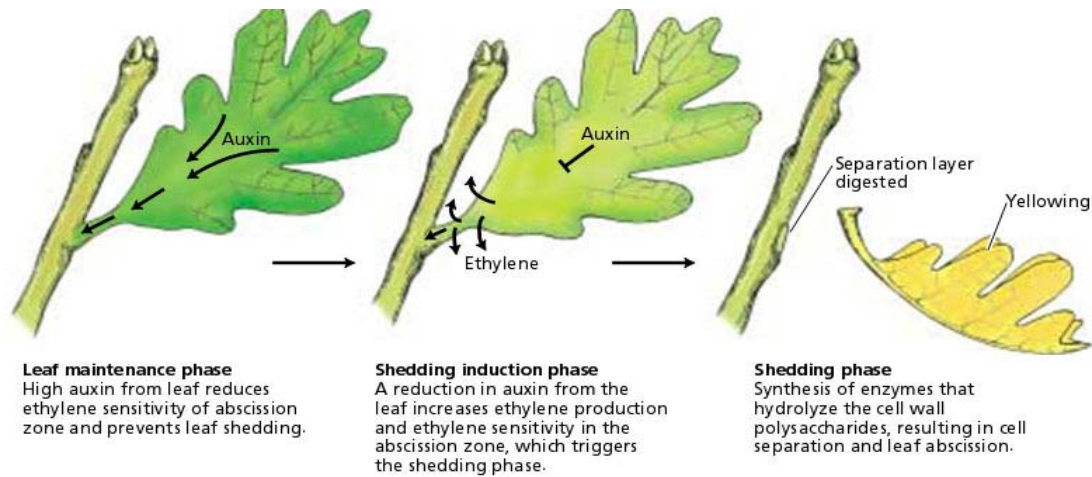

Figure 35 Ethylene Biosynthetic Pathway and Yang cycle. The amino acid Methionine is the precursor of ethylene.

Figure 36 - Schematic view of role of the auxin and ethylene during leaf abscission.



Purification of both ACS and ACC oxidases was difficult as ACS is low in abundance and ACC oxidase does not survive extraction. ACS is induced by auxin and LiCl. Aminooxyacetic acid (AOA) is an inhibitor of ACS. ACS requires pyridoxal phosphate as a prosthetic group of activity. L-vinylglycine is a competitive inhibitor of ACS. ACC oxidase (ACO) is ethylene forming enzyme (EFE). The mRNA of ACO is rapidly induced (i) after wounding of fruits and leaves (ii) early during fruit ripening and (iii) prior to would-associated ripening-associated increase in ethylene production. ACC oxidase activity was reduced in transgenic tomato expressing antisense EFE mRNA. Fe^{2+} and ascorbic acid increase activity of ACC oxidase. Conversion of ACC to ethylene requires oxygen. Two different systems control the ripening of fruits and flowers. System of ethylene production is auto-inhibitory and operative in both non-climacteric fruits and vegetative tissues. In the system-II ethylene production is autocatalytic. This is characteristic of climacteric fruits. During the ripening of climacteric fruits, there is a switch from system-I to system-II, depending upon of type(s) of ACC synthase and ethylene receptor produced. 1-Methylcyclopropene (1-MCP) and Norbornadiene ethylene antagonists reduces ethylene and ACC synthase production.

Perception and mode of action of ethylene:

Plants smell ethylene with the help of ethylene receptors. Ethylene insensitivity segregates as a dominant character. Tony Bleeker cloned *etr 1* from *Arabidopsis*. Mode of function is via a gain-of-function or dominant-negative mechanisms. Perception of ethylene occurs through a chain of events involving proteins that were first identified in *Arabidopsis*. Many key components of ethylene signal transduction pathway have been identified using effect of ethylene on dark-grown seedlings known as the 'triple response'.

In *Arabidopsis thaliana*, the triple response is characterized by (i) inhibition of hypocotyls and root elongation, (ii) a thickened hypocotyls, and (iii) an exaggerated apical hook. Populations of mutagenized *Arabidopsis* were screened for seedlings that displayed altered triple-response phenotype. This approach resulted in the identification of several ethylene-insensitive mutants. These mutants include *etr 1* (*ethylene response*), *etr 2*, *ein 2*



(*ethylene-insensitive*), *ein 3*, *ein 4*, *ein 5*, *ein 6*, *hls 1* (*hookless*) and *eir 1* (*ethylene insensitive root*). Mutants were also identified that exhibited a triple response in the absence of ethylene. These include *ctr 1* (*constitutive triple response*) and *ran 1* (*responsive to antagonist*).

Figure 37 - screen for the *etr1* mutant of *Arabidopsis*. Seedlings were grown for 3 days in the dark in ethylene. Note that all but one of the seedlings are exhibiting a triple response; exaggeration in curvature of the apical hook, inhibition and radical swelling of the hypocotyl and horizontal growth.

Genetic and molecular analyses of these mutants have defined a pathway for ethylene signal transduction from initial perception to transcriptional regulation. Ethylene is perceived by a family of five membrane-bound receptors (ETR 1, ETR 2, ERS 1, ERS 2, EIN 4) that have similarity to two-component regulators. ETR 1 was the first plant hormone receptor to be identified. ETR 2, ERS 1 (ETHYLENE RESPONSE SENSOR), ERS 2 and EIN 4, operate as negative regulators of ethylene signaling. These complexes compete to bind ethylene. Binding of ethylene to ethylene receptors results in an (inactive) configuration. This prevents interaction of ethylene with the negative response regulator CTR 1. As a result, ethylene responses are initiated. Conversely (if ethylene is absent), ETR 1 binds to CTR 1, which prevents ethylene signaling. Thus an important feature of the ethylene signaling pathway is that it contains both positive and negative regulators, some proteins thereby serving to induce the responses while others suppress them. According to the basic working model, the ethylene receptors activate the kinase activity of CTR 1 in the air (absence of ethylene). CTR 1 protein then actively suppresses the downstream responses so that EIN 2 and EIN 3/ETL 1 transcription factors remain inactive (engaged with CTR 1). When ethylene is present, the ER-localized, membrane-receptors bind to ethylene and no longer suppress the pathway. This relief of suppression allows for activation of EIN 2 (DNA-binding), induction of ethylene transcriptional cascade, and hence the establishment of ethylene responses. EIN 3 and EIL 1 act as master regulators of the ethylene response. The basic elements and mechanisms of the signal transduction pathway are conserved in agronomically important dicots and monocots (some differences are observed) including tomato, rice, cucurbits, carnation, pears, peach, maize, wheat, and passion fruit.

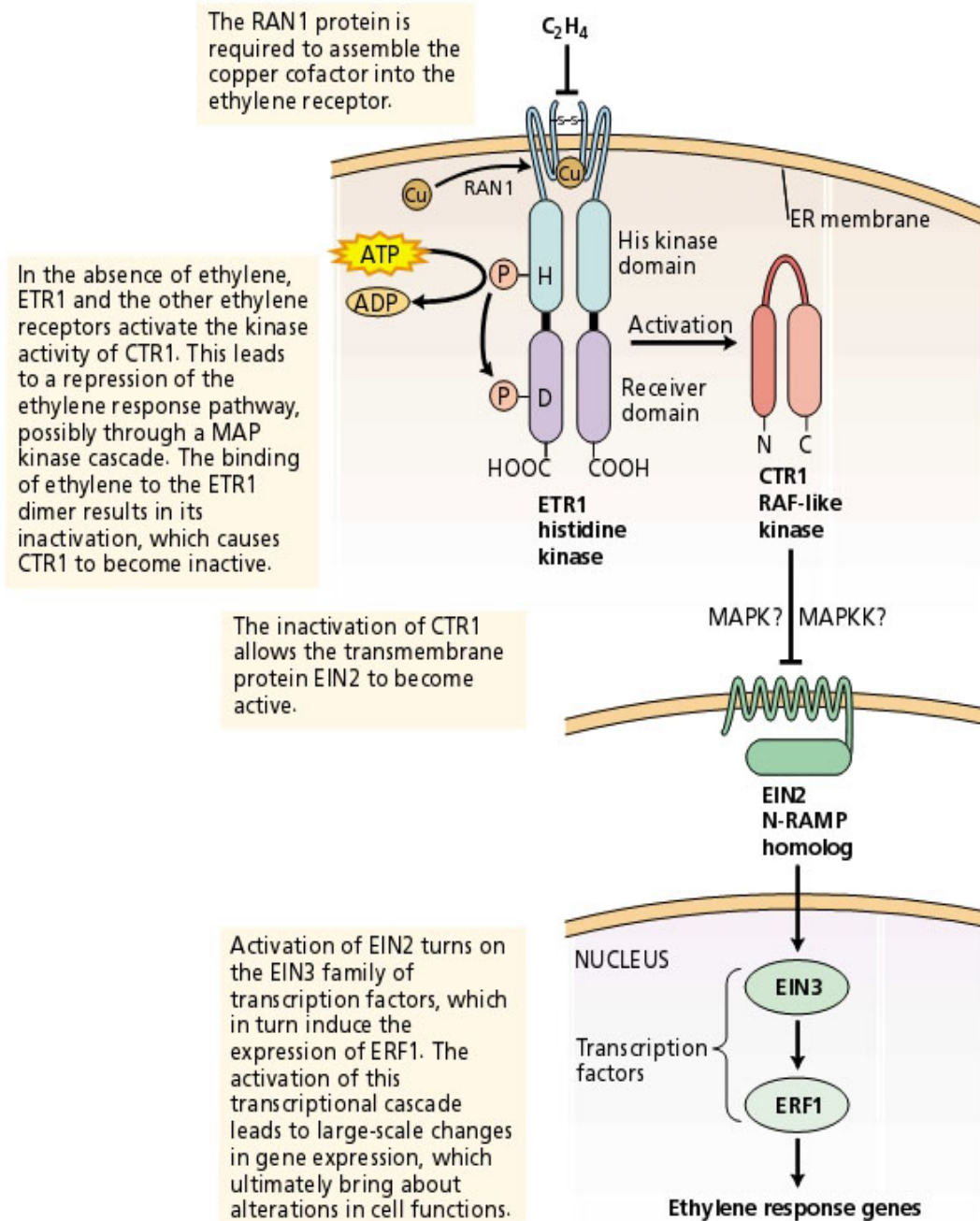

Figure 38 - Model of the ethylene signaling in *Arabidopsis*.

Gibberellins (GAs)

This important hormone was identified during studies of “bakane” (foolish) seedling disease in rice, responsible for greatly reduced yields in Japan, Taiwan and the Asian subcontinent in 1800s. Plant pathologists investigating the disease found that the tallness of the pale-yellow (elongated with slender leaves, stunted roots and little or no seed production) plants was induced by a chemical secreted by pathogenic fungus that had caused the disease. The causative agent of the ‘bakane’ disease was demonstrated to be fungus in a paper published by Shotaro Hori in 1898. A chemical was isolated from filterates of the cultured fungus *Gibberella fujikuroi* (*Fusarium moniliforme*) in 1926 by Eiichi Kurosawa. This chemical was named as gibberellin after the fungus in the 1930s by Teijiro Yabuta and Yusuke Sumiki who successfully crystallized it. The World War II delayed further studies and it was

not until the 1950s that a GA was isolated from plants, demonstrating it is an endogenous compound in plants. To day more than 125 different Gas are identified and have been found in all plant species examined along with some fungi and bacteria.

During the mid of 1950s groups working at the Imperial Chemical Industries (ICI) research station at Weyn in Britain and U.S. Department of Agriculture (USDA) in Peoria, Illinois succeeded in elucidating the structure of the chemical that they had purified from the cultural filtrate of the fungus, which they named gibberellic acid. Scientists of Tokyo University isolated three gibberellins from the original gibberellin A and named them gibberellin A₁, gibberellin A₂ and gibberellin A₃, Gibberellin A₃ and gibberellic acid found to be identical.

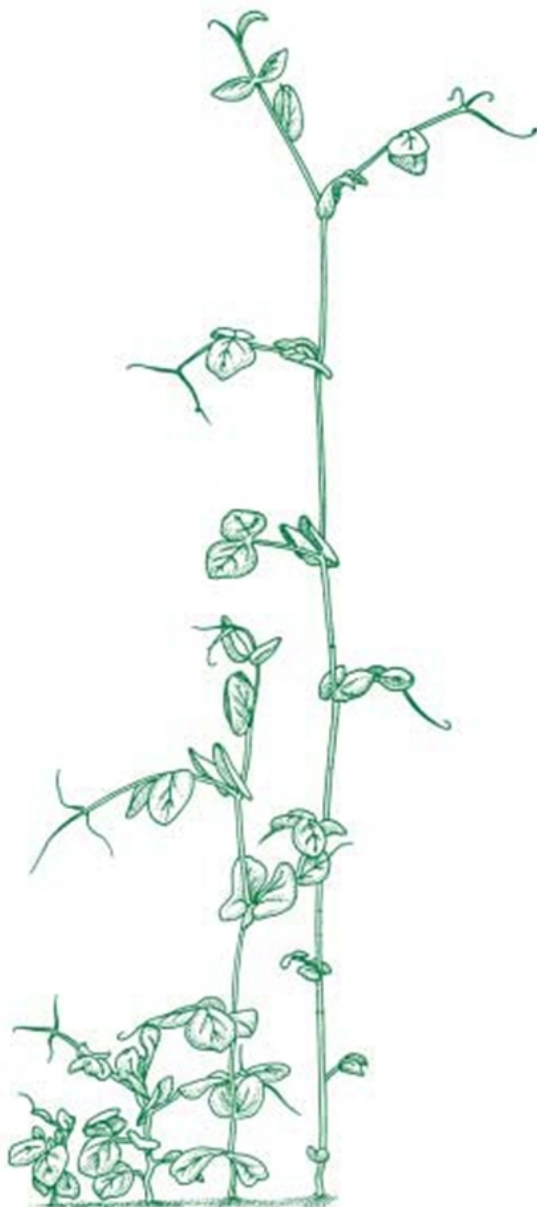

Figure 39- Phenotypes and Genotypes of Peas that differ in Gibberellin content of their vegetative tissue.

Ultradwarf:	Dwarf:	Tall:	Ultratall:
no GAs	contains	contains	contains
<i>nana</i>	GA ₂₀	GA ₁	no GAs
	<i>Na 1e</i>	<i>Na Le</i>	<i>na la crys</i>

The GA-genes of the Green Revolution :

The spectacular increases in wheat and rice yields during the ‘Green Revolution’ were enabled by the introduction of dwarfing traits into wheat and rice varieties by breeding. The wheat dwarfing genes of Green Revolution

originated in Japan. The Norin-10 dwarfing genes are now present in more than 70% of current commercial wheat cultivars of the world. The Green-Revolution in rice was dependent on introduction of semi-dwarf, high yielding INDICA cultivars. The dwarfing gene originated from a Chinese cultivar, Deo-geo-woo-gen, which was used in a breeding program in Taiwan during the 1950s to produce the highly successful Taichung Native 1 (TN-1), and later at the International Rice Research Institute (IRRI) in the Philippines to produce IR-8, the so-called 'miracle' rice. Now identification of the genes responsible for these traits shows that these genes interfere with the action or production of the gibberellin (GA) phytohormone. It is now known that wheat Rht gene encode growth repressors that are normally suppressed by GA. A rice gene sd 1 encode a defective enzyme in the GA biosynthetic pathway.



Figure40- Genetically engineered dwarf wheat plants. The untransformed wheat shown on the extreme left .the three plants on the right were transformed with a gibberellin 2-oxidase cDNA from bean under the control of a constitutive promote, so that the endogenous active GA1 was degraded the varying degree of dwarfing reflects varying degree of over expression of their foreign gene.

Biosynthesis of Gibberellins

The complex pathways of GA metabolism were elucidated first in *G. fujikuroi* and then in higher plants. Gibberellic acids are synthesized from trans-geranyl geranyl diphosphate (GGPP). GGPP is converted via ent-copalyl diphosphate (CPP) to the tetracyclic hydrocarbon ent-kaurene, which is then modified by sequential oxidation on C-19, C-7 and C-6 to produce Got₁₂-aldehyde. In plants, ent-kaurene formation from GGPP occurs in plastids and requires two diterpene cyclase, CPP synthase (CPS) and ent-kaurene synthase (KS), whereas a single enzyme catalyzes both steps in fungi. It has been suggested that mevalonate and mevalonate-independent pathways contribute to ent-kaurene biosynthesis.

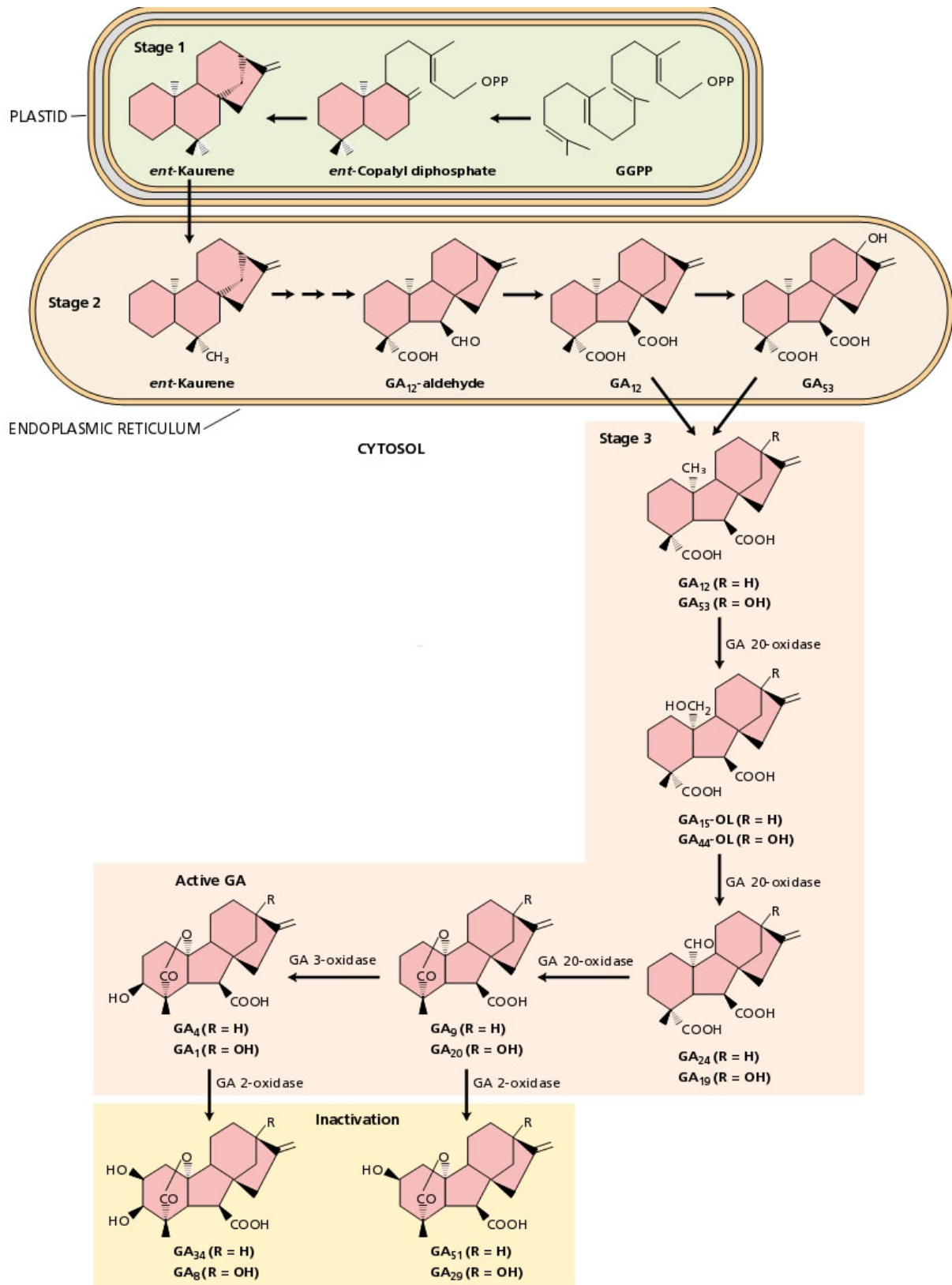

Figure41- The three stages of gibberellin synthesis.

The conversion of *ent*-kaurene via *ent*-kaurenoic acid and *ent*-7X- hydroxykaurenoic acid to GA_{12} -aldehyde is done by the action of cytochrome-P450-dependent mono-oxygenases. This reaction occurs outside plastids on membranes. Mono-oxygenases further catalyze the oxidation of GA_{12} -aldehyde at C-7 to give GA_{12} and GA_{12} to

GA₅₃. These two intermediates are substrates for the final stage of GA biosynthesis. They are converted to GA₉ and GA₂₀. The bioactive GAs, GA₄ and GA₁ are formed from GA₉ and GA₂₀ respectively. In some species GA₉ and GA₂₀ are also converted into GA₇ and GA₃ respectively. GAs are present in most vegetative and floral tissues at low concentrations (0.1 – 100.0 nanograms/g fresh weight) and their biosynthetic enzymes are similarly low in abundance. Regulation of biosynthesis in plants is controlled by several factors including control by developmental stage(s), hormones and phytochromes/ light. Chemical manipulation of the GA status of plants is widely practised in agriculture and horticulture GA levels can be manipulated by genetic manipulation/breeding methods. GA overproduction/GA biosynthesis suppression and alteration sensitivity of plants/genotypes have been achieved by genetic engineering. GA levels can be reduced by increasing the rate of inactivation.

Mode of Action of Gibberellins (GAs)

Of the more than 125 GAs that have been identified in plants and fungi, relatively few are thought to possess intrinsic biological activity. The most important bioactive GAs for vegetative growth and development are probably GA₁ and GA₄. The GA class of phytohormones is involved in many aspects of development throughout the life-cycle of higher plants. They affect seed germination, stem and petiole elongation, leaf expansion, flower and trichome initiation and development and growth of seed and fruit (fruit growth probably be creating a sink our photoassimilate). The GAs also mediates certain environmental effects on development. GA hormones are important in mediating plasticity to apical meristem damages (AMD). Gibberellin also affects root development by promoting cell elongation. GAs play important role in mobilization of reserve food in grass seeds. GAs act as stimulator in expression of the male sex in flowers. Based on vegetative phenotypes and response to GA, two classes of GA-response mutants have been identified through genetic approaches. The first group is GA-insensitive dwarf mutants which resemble mutants that are deficient in GA biosynthesis. These mutations result in plants that are stunted, have dark green leaves, and show defects in flower development and timing of flowering, but these are not rescued by exogenous application(s) of GA. These dwarf mutants have a phenotype similar to that of weak or “leaky” alleles of GA-deficient biosynthesis mutant (*GA auxotrophs*). This class includes the well known Rht (for reduced height). Wheat lines used to develop high-yielding short-stature wheat varieties that led to the GREEN REVOLUTION. The second group of GA-response mutations appears to confer a GA-independent phenotype to plants, of these, mutation in SPY gene are the best characterized. The identification of GA-response mutants in plants has proven instrumental in elucidating the GA-signaling pathway. Unlike auxin, abscisic acid, brassinosteroid cytokinin and ethylene receptors, which were all identified first in *Arabidopsis*, the gibberellin receptor was identified in rice by Makoto Matsuoka’s & laboratory. A recombinant GIBBERELLIN INSENSITIVE DWARF 1 (GID 1) has been shown to bind radio-labeled gibberellin in *in vitro* assays. GID 1 binds the SLENDER RICE (SLR 1) protein, a member of the DELLA class of transcriptional repressor, directly in a gibberellin-dependent manner. The DELLA proteins may directly block the GA-dependent transcription of target genes. As a consequence of GID 1 binding, SLR 1 is then targeted for degradation. This depends on the presence of a functional GID 1 protein and most likely occurs through the recruitment of an SCF GID 2 ubiquitin ligase complex, involving the F-box protein GID 2. The GID 1 gene encodes an unknown protein with similarity to the hormone-sensitive lipases, and it has been found located in nuclei.

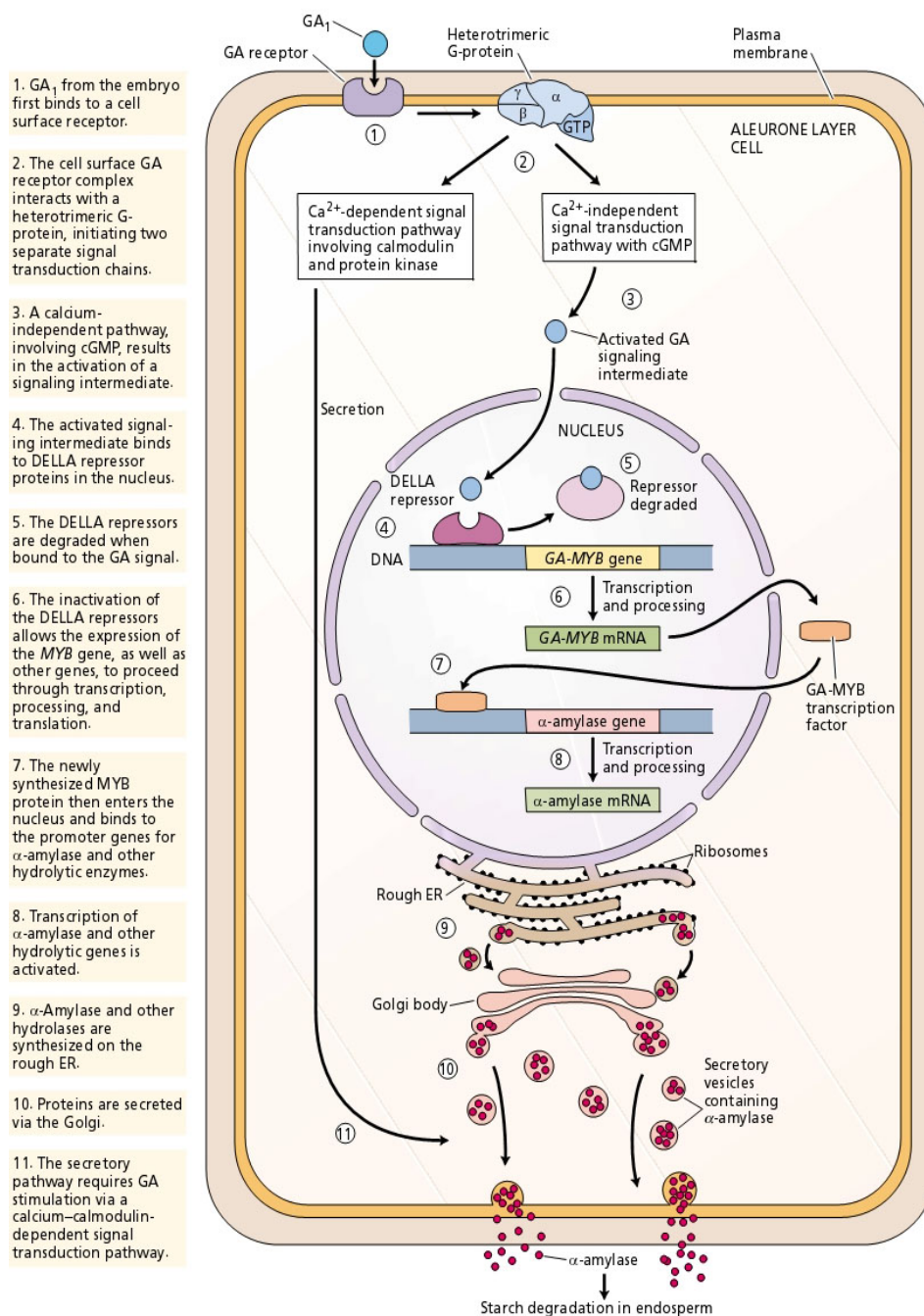

Figure 42- Pathway of GA signaling.

Brassinosteroids

Brassinosteroids (BRs) represent a new sixth class of plant hormones with wide occurrence in the plant kingdom in addition to abscisic acid, auxins, cytokinins, ethylene and gibberellins. The BRs have structural similarities to insect and animal steroid hormones.

The history of BRs started when Mitchell et al. (1970) screened pollen from nearly sixty species and half of them caused growth of bean seedlings. The substances from various pollen sources were named "brassin".

In 1979, Grove et al. showed the unique growth-promoting activities of extracts of Brassica pollens. This property was conferred by brassinolide, a C-8 steroid with an unusual lactone B-ring structure. Brassinolide(s) manifests biological activity on a wide range of plant species when applied exogenously, in some cases at doses as low as 1 μ g/individual plant. These polyhydroxy-steroid phytohormones control important developmental functions, such as growth, photomorphogenesis, fertility, seed germination and senescence. Brassinosteroids and their congeners have been reported to increase the yields of several commercially important crops as well as to improve their resistance to stresses caused by temperature extremes, drought, salinity and pathogens.

Figure 43- Phenotype of BR dwarf mutants. Comparison of several 5-week-old BR-deficient or -insensitive (*bri1*) mutant's of *Arabidopsis* with a wild-type *Arabidopsis* plant of the same age.



Biosynthesis of Brassionosteroids

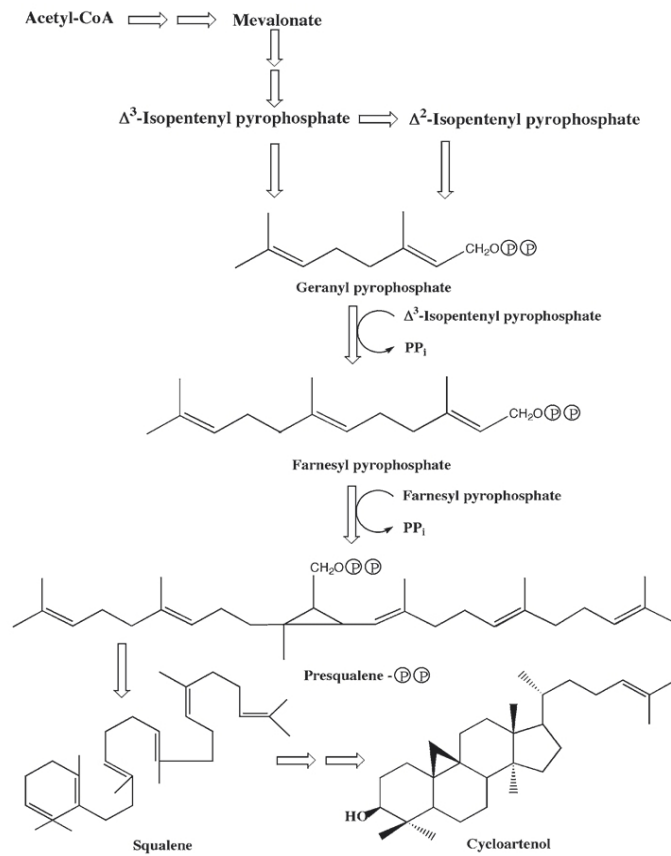

Figure44- Schematic Representation Of Biosynthesis Of Brassionosteroids

Plant sterols are synthesized from cycloartenol through a series of reactions including single or double methylation. The C₂₇ brassinosteroids, which have no alkyl substituent at position C₂₄, may be derived from cholesterol. The C₂₈ brassinosteroids have a methylene, α -methyl or β -methylene at C₂₄, which may come from 24-methylenecholesterol, campesterol or 24-epicampesterol, respectively. The C₂₉ brassinosteroids have either an ethylidene or α -ethyl group at C₂₄, likely to be derived from isofucosterol, or sitosterol, respectively. Furthermore, the C₂₉ brassinosteroids include a group of compounds with a methylene

At C₂₄, and an additional methyl at C₂₅, this is assumed to be derived from 25-methyl-24-methylenecholesterol.

Campesterol is the preferred precursor of brassinosteroids. The most abundantly and widely occurring brassinosteroids are brassinolide and its biosynthetically related steroids which are C₂₈ steroids with α -methyl at position C₂₄. These brassinosteroids have been demonstrated to be synthesized from Campesterol in transformed *Catharanthus roseus* (Sadababar). In the first biosynthetic reaction campesterol undergoes reduction to yield 5 α -campestenol which subsequently converted to brassinolide.

Campesterol is converted to 6 α -hydroxycampestanol which is in turn converted to 6-oxocampestanol. It is likely that 6-oxocampestanol is hydroxylated to the C₂₂ position to give 22 α -hydroxy-6-oxocampestanol (cathasterone). Cathasterone is converted through hydroxylation at C₂₃ position to yield teasterone, a frequently found plant brassinosteroid. Teasterone is converted to typhasterol. Conversion of teasterone to castasterone is known to occur in intact plants of *C.roseus*, tobacco and rice. Castasterone is converted to brassinolide in seedlings of *C.roseus*.

The biological activity of brassinolide and its biosynthetic intermediates has been examined using the rice lamina inclination bioassay and the wheat leaf unrolling test.

Functions of Brassinosteroids

Brassinosteroids elicit divergent biological activities. These include stem elongation, pollen tube growth, leaf bending, leaf unrolling, root inhibitions, proton pump activation, production of 1-aminocyclopropane-1-carboxylic acid production and xylogenesis. Brassinosteroids have been found to induce disease resistance in plants. Although there is evidence that brassinosteroids and auxin can operate independently, other studies have demonstrated a link between brassinosteroids and auxins, indicating that some pathways are under dual control.

Plant Receptors Perceive Steroid Signal: In plants, BRASSINOSTEROID INSENSITIVE1

(BRI1), a leucine-rich repeat (LRR) receptor kinase localizing to the plasma membrane, is a critical component of a receptor complex for brassinosteroids. It has been demonstrated in laboratory of Joanne Chory (The Salk Institute, USA) using Biotin-Tagged Photoaffinity castasterone (BPCs), a precursor of brassinolide (the most active of the brassinosteroids), that brassinosteroids directly bind to BRI1. Brassinosteroid binding occurs directly to a 94 amino acid comprising ID-LRR22 (the carboxyl terminal flanking LRR). A

Protein, BRI-1-ASSOCIATED RECEPTOR KINASE (BAK1) that can heterodimerize with BRI1, is also required for brassinosteroid signaling. The activation of the BRI1 and BAK1 receptor kinases that is stimulated by BR binding, leads to dephosphorylation and accumulation of the nuclear BR response protein BZR1 and BES1, possibly by inhibiting BIN2, a negative regulator of the BR-signaling pathway in plants.

In absence of Br, BIN2 phosphorylates BZR1 and BES1, thereby targeting them for degradation. BZR1 binds to specific DNA sequences that express the transcription of BR biosynthesis genes. BES1 also binds specific DNA sequences in association with the BIM protein and act as a transcriptional activator for BR response genes.

Jasmonic Acid and Derivatives (Jasmonates, JAs) as Plant Growth Regulators

Jasmonates have emerged as an important group of substances that regulate plant responses to pathogenic and beneficial microorganisms. Plants respond to many biotic and abiotic stresses are orchestrated locally and systemically by jasmonates. JAs also regulate such diverse processes as pollen maturation and wound responses in plants. The complex interplay of the Jas with the alarm signals Salicylic Acid (SA) and Ethylene (ET) provides plants with a regulatory potential that shapes the ultimate outcome of the plant-microbe interaction. Jasmonates are synthesized from fatty acid Linolenic Acid, LA (18:3). They may also be biosynthesized from Hexadecatrienoic acid (16:3). Chloroplast contains an abundance of LA esterified in glycerolipids and phospholipids. JAs levels have been shown to increase during senescence and several enzymes involved in JA biosynthesis exhibited senescence-enhanced expression.

Exogenous application of methyl jasmonate has been considered as effective at inducing secondary metabolites in plant cell cultures, expression of a set of defense genes and inducing resistance of host against post-harvest pathogens. Jasmonates also have significant role in various developmental processes. These influence storage organs formation; promote tuber formation in potato, yam as well as bulb formation in garlic and narcissus and affect morphology and dormancy development in Lily bulblets regenerated *in vitro*. Treatment of Wild-type *Arabidopsis* with JA causes in typical premature senescence symptoms that do not occur on the JA-insensitive mutant *coi1*. In barley treated with JAs loss of chlorophyll and reduction in levels of ribulose-1,5-bisphosphate carboxylase/oxygenase has been recorded, indicating that JAs induce senescence.

Jasmonates act at transcriptional level, and responsive genes have been identified in plants. Crosstalk between Salicylic Acid and JAs signaling is known.

Salicylic Acid (SA)-An Effector Molecule in Plants

Salicylic acid (from the Latin word for the willow tree, *Salix* from whose bark it can be obtained) is a beta hydroxy acid (BHA) with the formula $C_6H_4(OH)CO_2H$, where the OH group is adjacent to the carboxyl group. This colorless crystalline organic acid is widely used in organic synthesis. It is derived from the metabolism of salicin. It is probably best known as a compound that is chemically similar but not identical to the active component of aspirin. SA a phytohormone phenol is ubiquitous in plants generating a significant impact on plant growth and development, photosynthesis, transpiration, ion uptake and transport and also induces specific changes in leaf anatomy and chloroplast structure. SA is recognized as an endogenous signal, mediating in plant defense, against pathogens plays a role in the resistance of pathogens by inducing the production of 'pathogenesis-related proteins'. It is involved in the systemic acquired resistance [SAR] in which a pathogenic attack on older leaves causes the development of resistance in younger leaves, though whether SA is the transmitted signal is debatable. SA is that calorogenic substance that causes thermogenesis in *Arum* flowers. It has been shown to regulate a number of processes, including, flower induction, inhibition of phosphate and potassium uptake and ethylene synthesis and fruit ripening. There is also evidence for a role of SA in regulating plants responses to some abiotic stresses, in particular UV radiation and ozone. SA is both an uncoupler and an inhibitor of mitochondrial electron transport. It has been suggested that it induces some genes in plants.

Salicylic acid antagonizes gene induction by stress signaling molecule Jasmonic acid. Several SA-responsive genes are regulated by basic /leucine zipper-type transcription factors (of TGA family). TGA factors interact with NPR1, a central regulator of many SA-induced defense responses including SA/JA antagonism. SA might act as an enhancer of RNA-mediated silencing of virus (antiviral defense) in tobacco. Silencing suppressors, P1/HC-Pro also alter the SA-mediated defense in plants. Infection of Plum pox virus (PPV) in tobacco leaves could be limited by defense mechanism mediated both by RNA-silencing and SA.

Nitric Oxide (NO) as Phytohormone

Nitric oxide is both a gaseous free radical and a versatile cell-signaling effector that play important roles in diverse pathological processes. Recently it has emerged as a key signaling molecule in plants. NO production in plants is predominantly catalyzed by nitric oxide synthases (NOS). Nitric oxide can also be synthesized from nitrite via nitrate reductase (NR). NO production is induced by biotic and abiotic stimuli. Substantial NO is emitted from plants into the atmosphere. Conversely, atmospheric NO (a major greenhouse pollutant produced by fossil fuel combustion) can affect plants. Nitric oxide promotes leaf expansion, inhibits maturation and senescence, stimulates light-dependent germination and promotes deetiolation. It also affects stomatal closure, programmed cell death, iron-homeostasis and various other developmental processes including flower and root development. Excess endogenous NO reduces growth and delay development in plants.

Literature cited and suggested references

- 1) Lee et.al, (1995) Biosynthesis and metabolism of salicylic acid. PNAS, Vol, 92 4076-4079.
- 2) Turner et.al, (2002) The Jasmonate signal Pathway. The Plant Cell, S153-S164.
- 3) Pozo et.al, (2005) Jasmonates-Signals in Plant-Microbe Interactions. Journal of Plant Growth Regulation, 23; 211-22.
- 4) Lamotte et.al, (2005) Nitric oxide in plants: the biosynthesis and cell signaling properties of a fascinating molecule. Planta, 221; 1-4.
- 5) He et.al, (2004) Nitric Oxide Represses the Arabidopsis Floral Transition. Science, Vol, 305, 1968-1972
- 6) Lino Moritoshi (2006) towards understanding the ecological functions of tropisms: interactions among and effects of light on tropisms. Current Opinion in Plant Biology, 9; 89-93.
- 7) Kiss (2006) up, down and all around: how plants sense and respond to environmental stimuli. PNAS, Vol, 103, 829-830.
- 8) Baurle and Caroline Dean (2006) the Timing of Developmental Transition in Plants. Cell, May (19)
- 9) McClung (2006) Plant Circadian Rhythms. The Plant Cell, Vol.18, 792-803.
- 10) Peter Barlow (2005) Patterned cell determination in a plant tissue: the secondary phloem of trees. Bioessays, 27; 533-541.
- 11) Long (2006) Plant development: new models and approaches bring progress. Development, 133, 4609-4612.
- 12) Selosse (2005) Threshold models applied to seed germination ecology. New Phytologist, 165;338-341.
- 13) Baluska et.al, (2006) Cytokinesis in plant and animal cells : Endosomes 'shut the door'. Developmental Biology, 294,1-10.
- 14) Breton and Steve A. Kay (2007) Time for growth. Nature,Vol 448 .
- 15) Gtierrez (2005) Coupling cell proliferation and development in plants. Nature Cell Biology, Volume 7, NUMBER 6.
- 16) Stahl and Simon (2005) Plant stem cell niches. Int.J.Dev.Biol. 49;479-489.
- 17) Wei et.al, (2006) Research Progresses on Auxin Response Factors .Journal of Integrative Plant Biology, 48(6), 622-627.
- 18) Amasino (2004) Vernalization,Competence,and the Epigenetic Memory of Winter. The Plant Cell, Vol, 16; 2553-2559.
- 19) Rogers (2006) Programmed Cell Death in Floral Organs: How and Why do Flowers Die?. Annals of Botany, 97; 309-315.
- 20) Imaizumi et.al, In SYNC: The Ins and Outs of Circadian Oscillations in Calcium.Sci. STKE 390.
- 21) Paolo Mazzarello (1999) A unifying concept: the history of cell theory. NATURE CELL BIOLOGY ,vol 1.
- 22) Baluska (2004) Eukaryotic Cells and their Cell Bodies: Cell Theory Revised. Annals of Botany 94; 9-32.
- 23) Finch-Savage (2006) Seed dormancy and the control of germination. New Phytologist , 171:501-523.
- 24) Mathews (2006) Phytochrome –mediated development in land plants: red light sensing evolves to meet the challenges of changing light environments. Molecular Ecology, 15, 3483-3503.
- 25) Nambara (2005) Abscisic Acid Biosynthesis and Catabolism. Annu.Rev.Plant.Biol., 56,165-185.

- 26) Yu and Zheng (2006) Salicylic Acid Enhances Biocontrol Efficacy of the Antagonist *Cryptococcus Laurentii* in Apple Fruit. *J. Plant Growth Regul*, 25; 166-174.
- 27) Smet et.al, (2006) A novel role for abscisic acid emerges from underground. *Trends in Plant science*, Vol.11 No.9.
- 28) Bajguz (2007) Metabolism of brassinosteroids in plants. *Plant Physiology and Biochemistry*, 45, 95-107.
- 29) Quail (2007) Phytochrome – regulated Gene Expression. *Journal of Integrative Plant Biology*, 49(1); 11-20.
- 30) Zhou et.al, (2007) Timing of Photoperiodic Flowering: Light Perception and Circadian Clock. *Journal of Integrative Plant Biology*, 49 (1); 28-34.
- 31) Jiao (2007) Light –regulated transcriptional networks in higher plants. *Nature Review, Genetics*, Vol. 8, 217-230
- 32) Chen et.al, (2004) Light signal Transduction In Higher Plants. *Annu.Rev.Genet*, 38; 87-117.
- 33) Cashmore et.al, (1999) Cryptochromes: Blue Light Receptors for Plants and Animals. *Science*, Vol 284. 760-770
- 34) Maheshwari et.al, (1999) Novel light- activated protein kinases as key regulators of plant growth and development. *J.Biosci*, 24,(4), 499-514.
- 35) Ferreira (2005) Cytokinin signaling. *Current Opinion in Plant Biology*, 8; 518-525.
- 36) Wojtaszek (2001) Organismal view of a plant and a plant cell. *Act Biochimica Polonica*, Vol .48, 443-451.
- 37) Yakir et.al, (2007) Regulation of output from the plant circadian clock. *FEBS journal*, 274,335-345.
- 38) Poethig (1990) Phase Change and the regulation of Shoot Morphogenesis in plants. *Science*, Vol 250,923-926
- 39) Gray (2004) Hormonal Regulation of Plant Growth and Development. *PLoS Biology*, Vol.2(9),1270-1273
- 40) Bishopp et.al, (2006) Signs of change: hormone receptors that regulate plant development. *Development*, 133, 1857-1869.
- 41) Chow and McCourt (2006) Plant hormone receptors: perception is everything. *Genes and Development*,20; 1998-2008.
- 42) Trewavas (2004) Aspects of plant intelligence: an Answer to Firm. *Annals of Botany*, 93; 353-357.
- 43) Francis (2007) The plant cell cycle-15 Years on. *New Phytologist*, 174; 261-278.
- 44) Gresshoff (2002) All We Are Saying Is Give Plants a Chance! *Journal of Biomedicine and Biotechnology*, 2:3,115-116.
- 45) Corbesier et.al, (2007) FT protein Movement Contributes to Long-Distance signaling in floral induction of Arabidopsis. *Science*, Vol, 316, 1030-1033
- 46) Mathur (2004) Cell Shape development in plants. *Trends in Plant Science*, Vol 9, (12), 1360-1385.
- 47) Berleth and Sachs (2001) Plant morphogenesis: long distance co-ordination and local patterning. *Current Opinion in Plant Biology*, 4; 57-62.
- 48) Goldberg et.al, (1994) Plant Embryogenesis: Zygote to Seed. *American Association for the Advancement of Science*, Vol. 266,605-614.
- 49) Goldberg et.al, (1988) Plants: Novel Developmental Processes. *American Association for the Advancement of Science*, Vol. 240, 1460-1467.

- 50) Bennett (2003) the case for morphogenesis in plants. *Nature Cell Biol.*, Vol. 5(11),939-942
- 51) Corbesier and Coupland (2006) the quest for florigen: a review of recent progress. *Journal of Experimental Botany*, Vol.57 (13), 3395-3403.
- 52) Eckardt (2007) GA Perception and signal Transduction: Molecular interactions of the GA receptor GID1 with GA and the DELLA protein SLR1 in rice. *The Plant cell*, Vol 19; 2095-2097.
- 53) Giovannoni (2004) Genetic Regulation of fruit Development and Ripening. *The Plant cell*, Vol 16; S170-S180.
- 54) McClung et.al, (March 27, 2002) *The Arabidopsis Circadian System*. *The Arabidopsis Book*. American Society of Plant Biologists, Rockville, MD.
- 55) Niklas (2000) the Evolution of Plant Body Plans- A Biomechanical Perspective. *Annals of Botany*, 85, 411-438.
- 56) Lijsebettens and Montagu (2005) Historical Perspectives on plant developmental biology. *International J.Dev.Biol*, 49, 453-465.
- 57) Long (2006) Plant development: new models and approaches bring progress. *Development*, 133; 4609-4612.
- 58) Paciorek and Friml (2006) Auxin Signaling. *Journal of Cell Science*, Vol 119, 1199-1202.
- 59) Tanksley (2004) The Genetic, developmental and Molecular Bases of fruit Size and Shape Variation in Tomato. *The Plant cell*, Vol 16; S181-S189.
- 60) Baurle and Dean (2006) The Timing of Developmental Transitions in Plants. *Cell*, Vol.125, 655-664.
- 61) Tata (2005) One hundred years of hormones. *EMBO Reports*, Vol 6,490-496
- 62) Barry and Giovannoni (2007) Ethylene and Fruit Ripening. *Journal of Plant Growth Regulator*, 26:143–159.
- 63) Reinhardt and Kuhlemeier (2002) Plant architecture. *EMBO Reports*, Vol 3, No9, 846-851.
- 64) Gillaspay et.al, (1993) Fruits: A Developmental Perspective. *The Plant Cell*, Vol 5.
- 65) Giovannoni (2007) Fruit ripening mutants yield insights into ripening control. *Current Opinion in Plant Biology*, 10; 283-289.
- 66) Aksenova (2006) Florigen Goes Molecular: Seventy Years of the Hormonal Theory of Flowering Regulation. *Russian Journal of Plant Physiology*, Vol 53,401-406.
- 67) Razem et al., (2006) The RNA –Binding protein FCA is an Abscisic acid receptor. *Nature*, Vol 439,290-292
- 68) Schroeder and Nambara (2006) A Quick Release Mechanism for Abscisic Acid. *Cell* 126.
- 69) Poethig (2001) Life with 25,000 Genes. *Genome Res*.11; 313-316.
- 70) Casal et.al, (2004) Signaling for developmental plasticity. *Trends in Plant Science*, Vol.9, 309-314
- 71) Chailakkhyan,M.Kh. (1982) Regulation of the flowering of the higher plants. *Fiziologiya Rastenii*,Vol.29,134-246.
- 72) Wethoff,P (1998) *Molecular plant development from gene to plant*. Oxford University Press.